12-BIT, 80-MSPS ADC WITH BUFFERED ANALOG INPUTS

FEATURES

- **Maximum Sample Rate: 80 MSPS**
- **12-bit Resolution with No Missing Codes**
- **Buffered Analog Inputs with**
 - **Very Low Input Capacitance (< 2 pF)**
 - **High DC Resistance (5 kΩ)**
- **82 dBc SFDR and 70 dBFS SNR (-1 dBFS or 1.8 V_{pp} input)**
- **85 dBc SFDR (-6 dBFS or 1 V_{pp} input)**
- **3.5 dB Coarse Gain and up to 6 dB Programmable Fine Gain for SNR and SFDR Trade-Off**
- **Parallel CMOS and Double Data Rate (DDR) LVDS Output Options**
- **Supports Sine, LVCMOS, LVPECL, LVDS Clock Inputs and Clock Amplitude Down to 400 mV_{PP}**
- **Clock Duty Cycle Stabilizer**
- **Internal Reference with Support for External Reference**
- **External Decoupling Eliminated for References**
- **Programmable Output Clock Position and Drive Strength to Ease Data Capture**
- **3.3 V Analog and 1.8 V to 3.3 V Digital Supply**
- **32-pin QFN Package (5 mm × 5 mm)**
- **Pin Compatible 12-Bit Family (ADS612X)**
- **Temperature range -40°C to 85°C**

APPLICATIONS

- **Wireless Communications Infrastructure**
- **Software Defined Radio**
- **Power Amplifier Linearization**
- **802.16d/e**
- **Test and Measurement Instrumentation**
- **High Definition Video**
- **Medical Imaging**
- **Radar Systems**

DESCRIPTION

ADS61B23 is a 12-bit A/D converter (ADC) with a maximum sampling frequency of 80 MSPS. It combines high performance and low power consumption in a compact 32-QFN package. The analog inputs use buffers to isolate the switching transients of the internal sample & hold from the external driving circuit. The buffered inputs present very low input capacitance (< 2pF) & wide bandwidth. This makes it easy to drive them at high input frequencies, compared to an ADC without the input buffers.

ADS61B23 has coarse and fine gain options that are used to improve SFDR performance at lower full-scale analog input ranges.

The digital data outputs are parallel CMOS or DDR LVDS (Double Data Rate). Several features exist to ease data capture—controls for output clock position and output buffer drive strength, plus LVDS current and internal termination programmability.

The output interface type, gain, and other functions are programmed using a 3-wire serial interface. Alternatively, some of these functions are configured using dedicated parallel pins so the device starts in the desired state after power-up.

ADS61B23 includes internal references, while eliminating the traditional reference pins and associated external decoupling. External reference mode is also supported.



Please be aware that an important notice concerning availability, standard warranty, and use in critical applications of Texas Instruments semiconductor products and disclaimers thereto appears at the end of this data sheet.



This integrated circuit can be damaged by ESD. Texas Instruments recommends that all integrated circuits be handled with appropriate precautions. Failure to observe proper handling and installation procedures can cause damage.

ESD damage can range from subtle performance degradation to complete device failure. Precision integrated circuits may be more susceptible to damage because very small parametric changes could cause the device not to meet its published specifications.

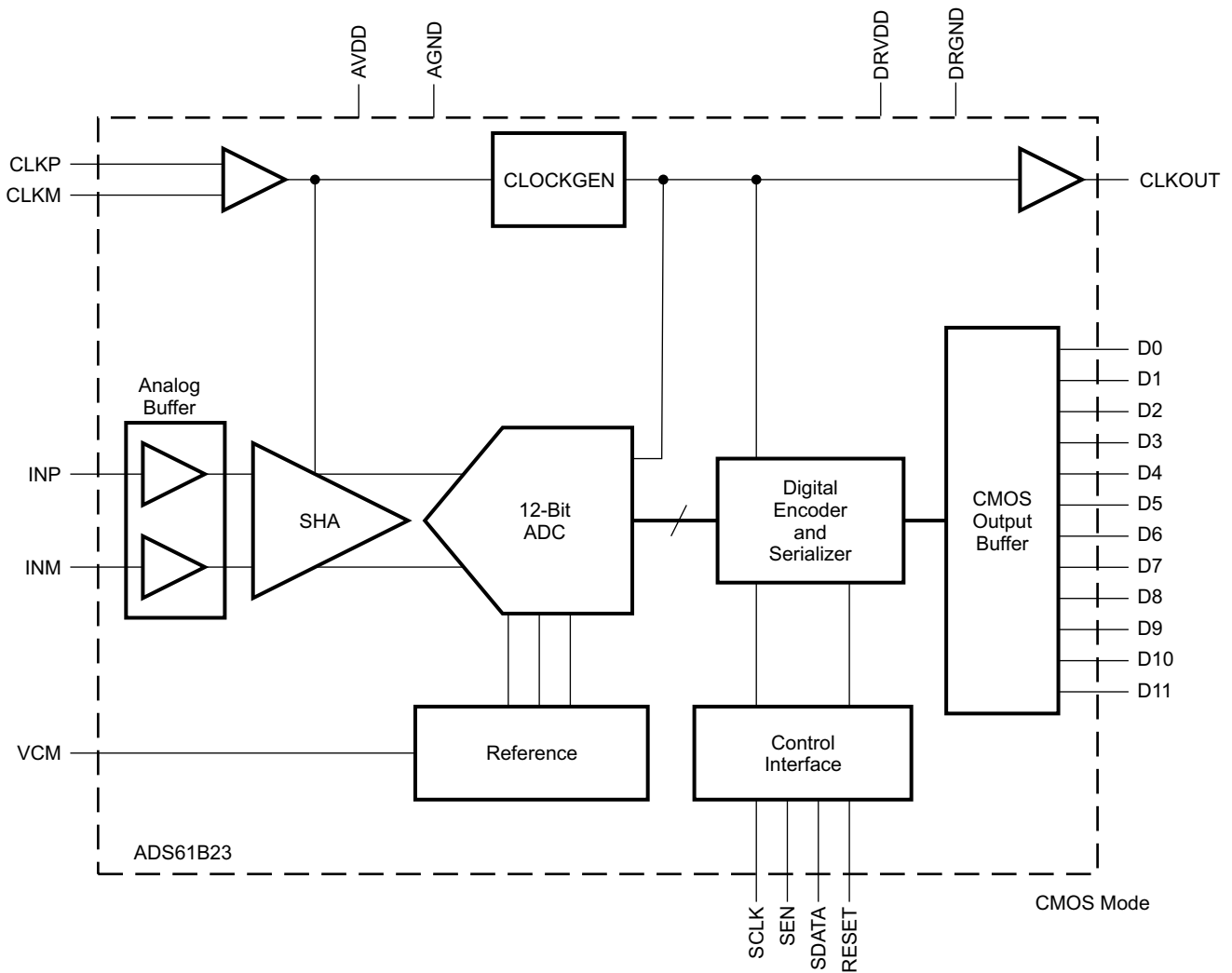

B0290-01

PACKAGE/ORDERING INFORMATION⁽¹⁾

PRODUCT	PACKAGE-LEAD	PACKAGE DESIGNATOR	SPECIFIED TEMPERATURE RANGE	PACKAGE MARKING	ORDERING NUMBER	TRANSPORT MEDIA, QUANTITY
ADS61B23	QFN-32 ⁽²⁾	RHB	–40°C to 85°C	AZ61B23	ADS61B23IRHBT	Tape and Reel, 250
					ADS61B23IRHBR	Tape and Reel, 3000

- (1) For the most current package and ordering information, see the Package Option Addendum at the end of this document, or see the TI website at www.ti.com.
- (2) For thermal pad size on the package, see the mechanical drawings at the end of this data sheet. $\theta_{JA} = 34 \text{ }^\circ\text{C/W}$ (0 LFM air flow), $\theta_{JC} = 30 \text{ }^\circ\text{C/W}$ when used with 2 oz. copper trace and pad soldered directly to a JEDEC standard four layer 3 in \times 3 in (7.62 cm \times 7.62 cm) PCB.

ABSOLUTE MAXIMUM RATINGS⁽¹⁾

		VALUE	UNIT
V _I	Supply voltage range, AVDD	–0.3 to 3.9	V
	Supply voltage range, DRVDD	–0.3 to 3.9	V
Voltage between AGND and DRGND		–0.3 to 0.3	V
Voltage between AVDD to DRVDD		–0.3 to 3.3	V
Voltage applied to VCM pin (in external reference mode)		–0.3 to 2	V
Voltage applied to analog input pins, INP and INM		–0.3 to minimum (3.6, AVDD + 0.3)	V
Voltage applied to analog input pins, CLKP and CLKM		–0.3 to (AVDD + 0.3)	V
T _A	Operating free-air temperature range	–40 to 85	°C
T _J	Operating junction temperature range	125	°C
T _{stg}	Storage temperature range	–65 to 150	°C

- (1) Stresses beyond those listed under *absolute maximum ratings* may cause permanent damage to the device. These are stress ratings only, and functional operation of the device at these or any other conditions beyond those indicated under *recommended operating conditions* is not implied. Exposure to absolute-maximum-rated conditions for extended periods may affect device reliability.

RECOMMENDED OPERATING CONDITIONS

over operating free-air temperature range (unless otherwise noted)

		MIN	NOM	MAX	UNIT	
SUPPLIES						
AVDD	Analog supply voltage	3	3.3	3.6	V	
DRVDD	Output buffer supply voltage	CMOS Interface	1.65	1.8 to 3.3	3.6	V
		LVDS Interface	3	3.3	3.6	V
ANALOG INPUTS						
Differential input voltage range		2			V _{pp}	
Voltage applied on VCM in external reference mode		1.45	1.5	1.55	V	
CLOCK INPUT						
F _S	Input clock sample rate	1		80	MSPS	
Input clock amplitude differential (V _{CLKP} – V _{CLKM})	Sine wave, ac-coupled	0.4	1.5		V _{pp}	
	LVPECL, ac-coupled	± 0.8				
	LVDS, ac-coupled	± 0.35				
	LVC MOS, ac-coupled	3.3				
Input Clock duty cycle		35%	50%	65%		
DIGITAL OUTPUTS						
Output buffer drive strength ⁽¹⁾	For C _{LOAD} ≤ 5 pF and DRVDD ≥ 2.2 V	DEFAULT strength				
	For C _{LOAD} > 5 pF and DRVDD ≥ 2.2 V	MAXIMUM strength				
	For DRVDD < 2.2 V	MAXIMUM strength				
C _{LOAD}	Maximum external load capacitance from each output pin to DRGND	CMOS Interface, maximum buffer strength	10		pF	
		LVDS Interface, without internal termination	5			
		LVDS Interface, with internal termination	10			
R _{LOAD}	Differential load resistance (external) between the LVDS output pairs	100			Ω	
T _A	Operating free-air temperature	-40		85	°C	

(1) See [Output Buffer Strength Programmability](#) in application section

ELECTRICAL CHARACTERISTICS

Typical values are specified at 25°C, AVDD= 3.3 V, DRVDD=1.8 to 3.3 V, sampling frequency = 80 MSPS, –1 dBFS differential analog input (1.8Vpp) , internal reference mode & apply to CMOS and LVDS interfaces, unless otherwise noted. Min and max values are specified across the full temperature range $T_{MIN} = -40^{\circ}\text{C}$ to $T_{MAX} = 85^{\circ}\text{C}$ at AVDD = 3.3 V, DRVDD = 3.3 V.

PARAMETER	ADS61B23 F _S = 80 MSPS			UNIT
	MIN	TYP	MAX	
RESOLUTION	12			Bits
ANALOG INPUT				
Differential input voltage range	2			V _{PP}
Input resistance from each input pin to ground (at dc) see Figure 32	5			kΩ
Input capacitance from each input pin to ground see Figure 33	< 2			pF
Analog input bandwidth	> 800			MHz
REFERENCE VOLTAGES				
VREFB Internal reference bottom voltage	1			V
VREFT Internal reference top voltage	2			V
ΔV _{REF} Internal reference error (VREFT–VREFB)	–20	± 5	20	mV
DC ACCURACY				
No missing codes	Specified			
E _O Offset error	–10	± 2	10	mV
Offset error temperature coefficient	0.05			mV/°C
There are two sources of gain error – internal reference inaccuracy and channel gain error				
E _{GREF} Gain error due to internal reference inaccuracy alone, (ΔV _{REF}) %	–2	0.25	2	% FS
E _{GCHAN} Gain error of channel alone ⁽¹⁾	–1	± 0.3	1	% FS
Channel gain error temperature coefficient	0.005			Δ%/°C
DNL Differential non-linearity	–0.75	± 0.5	2	LSB
INL Integral non-linearity	–3	± 1	3	LSB
POWER SUPPLY				
I _{AVDD} Analog supply current	104			mA
I _{DRVDD} Digital supply current, CMOS interface DRVDD = 1.8V No load capacitance, F _{IN} = 2 MHz ⁽²⁾	4.5			mA
I _{DRVDD} Digital supply current, LVDS interface DRVDD = 3.3V With 100 Ω external termination	42			mA
Total power, CMOS	351	475		mW
Global power down	30	60		mW

(1) This is specified by design and characterization; it is not tested in production.

(2) In CMOS mode, the DRVDD current scales with the sampling frequency and the load capacitance on output pins (see [Figure 26](#)).

ELECTRICAL CHARACTERISTICS

Typical values are specified at 25°C, AVDD= 3.3 V, DRVDD=1.8 to 3.3 V, sampling frequency = 80 MSPS, 50% clock duty cycle, -1 dBFS differential analog input (1.8Vpp) , internal reference mode & apply to CMOS and LVDS interfaces, unless otherwise noted.

Min and max values are specified across the full temperature range T_{MIN} = -40°C to T_{MAX} = 85°C at AVDD = 3.3 V & DRVDD = 3.3 V.

PARAMETER	TEST CONDITIONS	ADS61B23 F _s = 80 MSPS			UNIT	
		MIN	TYP	MAX		
DYNAMIC AC CHARACTERISTICS						
SNR Signal to noise ratio	Fin = 10 MHz		70.2		dBFS	
	Fin = 50 MHz		68.5	70		
	Fin = 70 MHz		69.9			
	Fin = 100 MHz	0 dB Gain		69.7		
		3.5 dB Coarse gain		68.7		
	Fin = 130 MHz	0 dB Gain		69.5		
3.5 dB Coarse gain			68.4			
SINAD Signal to noise and distortion ratio	Fin = 10 MHz		69.8		dBFS	
	Fin = 50 MHz		68	69.7		
	Fin = 70 MHz		69.3			
	Fin = 100 MHz	0 dB Gain		69.2		
		3.5 dB Coarse gain		68.4		
	Fin = 130 MHz	0 dB Gain		67		
3.5 dB Coarse gain			68			
ENOB Effective number of bits	Fin = 50 MHz		11	11.3	Bits	
SFDR Spurious free dynamic range	Fin = 10 MHz		82		dBc	
	Fin = 50 MHz		78	82		
	Fin = 70 MHz		78			
	Fin = 100 MHz	0 dB Gain		82		
		3.5 dB Coarse gain		87		
	Fin = 130 MHz	0 dB Gain		71		
3.5 dB Coarse gain			77			
SFDR Spurious free dynamic range (-6 dBFS or 1Vpp input)	Fin = 10 MHz		87		dBc	
	Fin = 50 MHz		85			
	Fin = 70 MHz		85			
	Fin = 100 MHz		85			
	Fin = 130 MHz		78			
THD Total harmonic distortion	Fin = 10 MHz		80		dBc	
	Fin = 50 MHz		75	80		
	Fin = 70 MHz		75			
	Fin = 100 MHz	0 dB Gain		79		
		3.5 dB Coarse gain		83		
	Fin = 130 MHz	0 dB Gain		69		
3.5 dB Coarse gain			75			
THD Total harmonic distortion (-6 dBFS or 1Vpp input)	Fin = 10 MHz		85		dBc	
	Fin = 50 MHz		82			
	Fin = 70 MHz		83			
	Fin = 100 MHz		82			
	Fin = 130 MHz		76			

ELECTRICAL CHARACTERISTICS (continued)

Typical values are specified at 25°C, AVDD= 3.3 V, DRVDD=1.8 to 3.3 V, sampling frequency = 80 MSPS, 50% clock duty cycle, -1 dBFS differential analog input (1.8Vpp) , internal reference mode & apply to CMOS and LVDS interfaces, unless otherwise noted.

Min and max values are specified across the full temperature range $T_{MIN} = -40^{\circ}C$ to $T_{MAX} = 85^{\circ}C$ at AVDD = 3.3 V & DRVDD = 3.3 V.

PARAMETER	TEST CONDITIONS		ADS61B23 F _s = 80 MSPS			UNIT	
			MIN	TYP	MAX		
HD2 Second harmonic distortion	Fin = 10 MHz			90		dBc	
	Fin = 50 MHz		78	88			
	Fin = 70 MHz			86			
	Fin = 100 MHz	0 dB Gain			86		
		3.5 dB Coarse gain			88		
	Fin = 130 MHz	0 dB Gain			86		
3.5 dB Coarse gain				88			
HD3 Third harmonic distortion	Fin = 10 MHz			82		dBc	
	Fin = 50 MHz		78	82			
	Fin = 70 MHz			78			
	Fin = 100 MHz	0 dB Gain			82		
		3.5 dB Coarse gain			87		
	Fin = 130 MHz	0 dB Gain			71		
3.5 dB Coarse gain				77			
Worst spur (Other than HD2, HD3)	Fin = 10 MHz			95		dBc	
	Fin = 50 MHz			94			
	Fin = 70 MHz			94			
	Fin = 100 MHz			92			
	Fin = 130 MHz			92			
IMD 2-Tone intermodulation distortion	F1 = 46 MHz, F2 = 50 MHz Each tone at -7 dBFS			85		dBFS	
Input overload recovery	Recovery to within 1% (of final value) for 6-dB overload with sine wave input			1		clock cycles	
PSRR AC Power supply rejection ratio	For 100 mVpp signal on AVDD supply			35		dBc	

DIGITAL CHARACTERISTICS⁽¹⁾

The DC specifications refer to the condition where the digital outputs are not switching, but are permanently at a valid logic level 0 or 1 with AVDD = 3.0 to 3.6 V.

PARAMETER	TEST CONDITIONS	ADS61B23			UNIT
		MIN	TYP	MAX	
DIGITAL INPUTS					
High-level input voltage		2.4			V
Low-level input voltage				0.8	V
High-level input current			33		μA
Low-level input current			-33		μA
Input capacitance			4		pF
DIGITAL OUTPUTS – CMOS INTERFACE, DRVDD = 1.65 to 3.6 V					
High-level output voltage			DRV DD		V
Low-level output voltage			0		V
Output capacitance	Output capacitance inside the device, from each output to ground		2		pF
DIGITAL OUTPUTS – LVDS INTERFACE, DRVDD = 3.0 V to 3.6 V, I_O = 3.5 mA, R_L = 100 Ω⁽²⁾					
High-level output voltage			1375		mV
Low-level output voltage			1025		mV
Output differential voltage, V _{OD}			225 350		mV
V _{OS} Output offset voltage, single-ended	Common-mode voltage of OOTP, OUTM		1200		mV
Output capacitance	Output capacitance inside the device, from either output to ground		2		pF

- (1) All LVDS and CMOS specifications are characterized, but not tested at production.
- (2) I_O Refers to the LVDS buffer current setting, R_L is the differential load resistance between the LVDS output pair.

TIMING CHARACTERISTICS – LVDS AND CMOS MODES⁽¹⁾

Typical values are specified at 25°C, AVDD= 3.3 V, sampling frequency = 80 MSPS, 50% clock duty cycle, sine wave input clock, 1.5 V_{PP} clock amplitude, C_L = 5 pF⁽²⁾, I_O = 3.5 mA, R_L = 100 Ω⁽³⁾, no internal termination & apply to CMOS and LVDS interfaces, unless otherwise noted.

Min and max values are specified across the full temperature range T_{MIN} = –40°C to T_{MAX} = 85°C for AVDD = 3.0 to 3.6 V, unless otherwise noted.

For timings at lower sampling frequencies, see the [APPLICATION INFORMATION](#) section of this data sheet.

PARAMETER	TEST CONDITIONS	ADS61B23 F _s = 80 MSPS			UNIT
		MIN	TYP	MAX	
t _a	Aperture delay	0.7	1.5	2.5	ns
t _j	Aperture jitter	150			fs rms
Wake-up time (to valid data)	From global power down	15 50			μs
	From standby	15 50			μs
	From output buffer disable	CMOS		100 200	ns
		LVDS		200 500	ns
Latency		9			clock cycles
DDR LVDS MODE⁽⁴⁾, DRVDD = 3.0 to 3.6 V					
t _{su}	Data setup time ⁽⁵⁾	Data valid ⁽⁶⁾ to zero-cross of CLKOUTP			ns
t _h	Data hold time ⁽⁵⁾	Zero-cross of CLKOUTP to data becoming invalid ⁽⁶⁾			ns
t _{PDI}	Clock propagation delay	Input clock rising edge zero-cross to output clock rising edge zero-cross			ns
	LVDS bit clock duty cycle	Duty cycle of differential clock, (CLKOUTP-CLKOUTM) 10 ≤ F _s ≤ 125 MSPS			
t _r t _f	Data rise time, Data fall time	Rise time measured from –50 mV to 50 mV Fall time measured from 50 mV to –50 mV 1 ≤ F _s ≤ 125 MSPS			ps
t _{CLKRISE} t _{CLKFALL}	Output clock rise time, Output clock fall time	Rise time measured from –50 mV to 50 mV Fall time measured from 50 mV to –50 mV 1 ≤ F _s ≤ 125 MSPS			ps
PARALLEL CMOS MODE, DRVDD = 2.5 V to 3.6 V, default output buffer drive strength⁽⁷⁾					
t _{su}	Data setup time ⁽⁵⁾	Data valid ⁽⁸⁾ to 50% of CLKOUT rising edge			ns
t _h	Data hold time ⁽⁵⁾	50% of CLKOUT Rising edge to data becoming invalid ⁽⁸⁾			ns
t _{PDI}	Clock propagation delay	Input clock rising edge zero-cross to 50% of CLKOUT rising edge			ns
	Output clock duty cycle	Duty cycle of output clock (CLKOUT) 10 ≤ F _s ≤ 125 MSPS			
t _r t _f	Data rise time, Data fall time	Rise time measured from 20% to 80% of DRVDD Fall time measured from 80% to 20% of DRVDD 1 ≤ F _s ≤ 125 MSPS			ns
t _{CLKRISE} t _{CLKFALL}	Output clock rise time, Output clock fall time	Rise time measured from 20% to 80% of DRVDD Fall time measured from 80% to 20% of DRVDD 1 ≤ F _s ≤ 125 MSPS			ns

(1) Timing parameters are specified by design and characterization and not tested in production.

(2) C_L is the Effective external single-ended load capacitance between each output pin and ground.

(3) I_O Refers to the LVDS buffer current setting; R_L is the differential load resistance between the LVDS output pair.

(4) Measurements are done with a transmission line of 100 Ω characteristic impedance between the device and the load.

(5) Setup and hold time specifications take into account the effect of jitter on the output data and clock.

(6) Data valid refers to logic high of +100 mV and logic low of –100 mV.

(7) For DRVDD < 2.2V, it is recommended to use external clock for data capture and NOT the device output clock signal (CLKOUT). See [Parallel CMOS interface](#) in the [APPLICATION INFORMATION](#) section

(8) Data valid refers to logic high of 2V (1.7V) and logic low of 0.8 V (0.7V) for DRVDD = 3.3V (2.5V).

Table 1. Timing Characteristics at Lower Sampling Frequencies ⁽¹⁾⁽²⁾

Fs, MSPS	t _{su} DATA SETUP TIME, ns			t _h DATA HOLD TIME, ns			t _{pDI} CLOCK PROPAGATION DELAY, ns			
	MIN	TYP	MAX	MIN	TYP	MAX	MIN	TYP	MAX	
CMOS INTERFACE, DRVDD = 2.5 V to 3.6 V										
65	5.1	6.6		3.8	5		5	6.5	7.9	
40	6.5	8		5.3	6.5					
20	11.3	12.8		10	11.2					
10	23	25		21	23					
DDR LVDS INTERFACE, DRVDD = 3.0 V to 3.6 V										
65	5.4	6		0.7	1.7		4.3	5.8	7.3	
40	10.2	10.8						4.3	5.8	7.3
20	22	23						4.5	6.5	8.5
10	47	48						4.5	6.5	8.5

- (1) Timing parameters are specified by design and characterization and not tested in production.
- (2) Timings are specified with default output buffer drive strength and C_L = 5 pF.

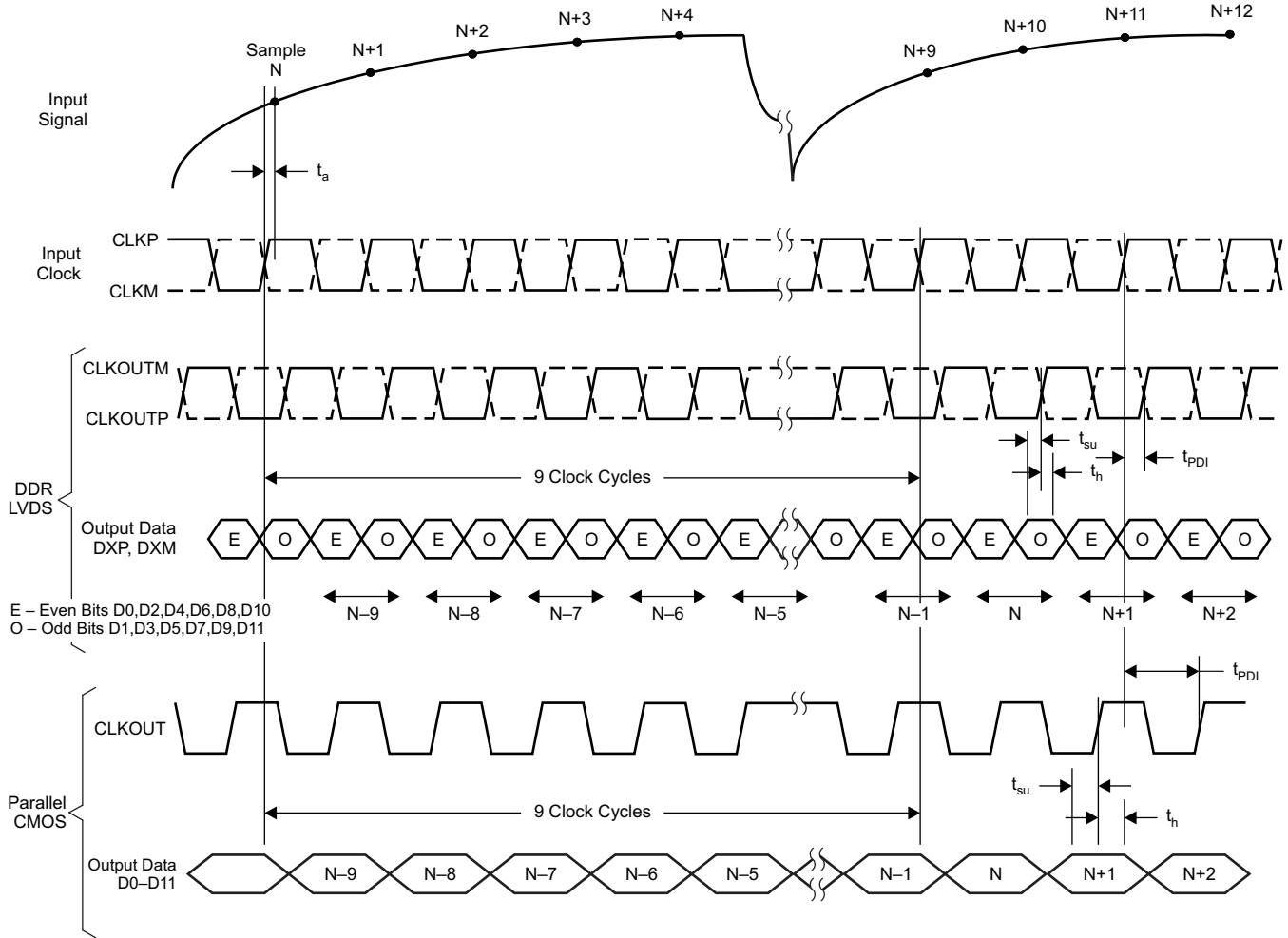
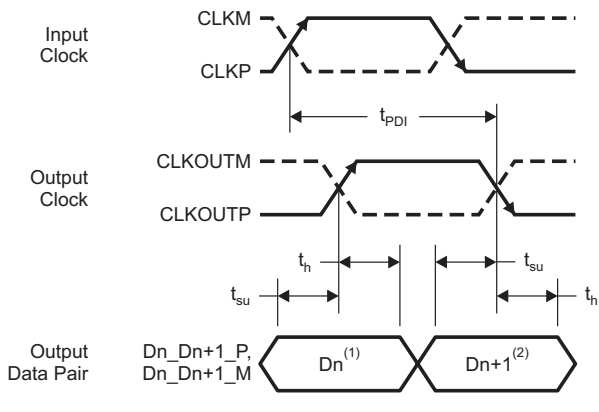

Figure 1. Latency



⁽¹⁾Dn – Bits D0, D2, D4, D6, D8, D10

⁽²⁾Dn+1 – Bits D1, D3, D5, D7, D9, D11

Figure 2. LVDS Mode Timing

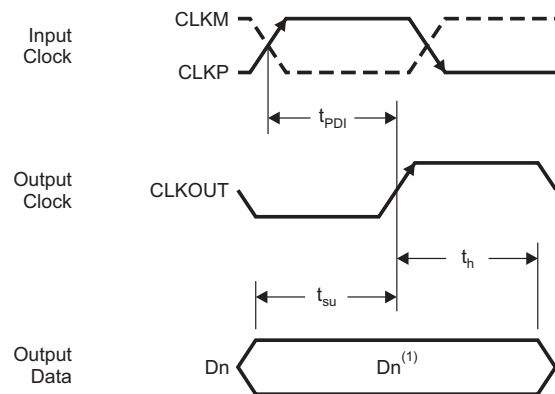

⁽¹⁾Dn – Bits D0–D11

Figure 3. CMOS Mode Timing

DEVICE PROGRAMMING MODES

ADS61B23 has several features that can be easily configured using a parallel interface control or serial interface programming.

USING SERIAL INTERFACE PROGRAMMING ONLY

To program using the serial interface, the internal registers must first be reset to their default values, and the RESET pin must be kept **low**. In this mode, SEN, SDATA, and SCLK function as serial interface pins and are used to access the internal registers of ADC. The registers are reset either by applying a pulse on the RESET pin, or by a **high** setting on the <RST> bit (D4 in register 0x00). The [Serial Interface](#) section describes register programming and register reset in more detail.

USING PARALLEL INTERFACE CONTROL ONLY

To control the device using parallel interface, keep RESET tied to **high** (AVDD). Now, SEN, SCLK, SDATA and PDN function as parallel interface control pins. These pins can be used to directly control certain modes of the ADC by connecting them to the correct voltage levels (as described in [Table 2](#) to [Table 4](#)). There is no need to apply a reset pulse.

Frequently used functions are controlled in this mode—standby, selection between LVDS/CMOS output format, internal/external reference, and 2s complement/straight binary output format. [Table 2](#)(SCLK Control Pin), [Table 3](#)(SEN Control Pin), and [Table 4](#)(SDATA, PDN Control Pin) describe the modes controlled by the parallel pins.

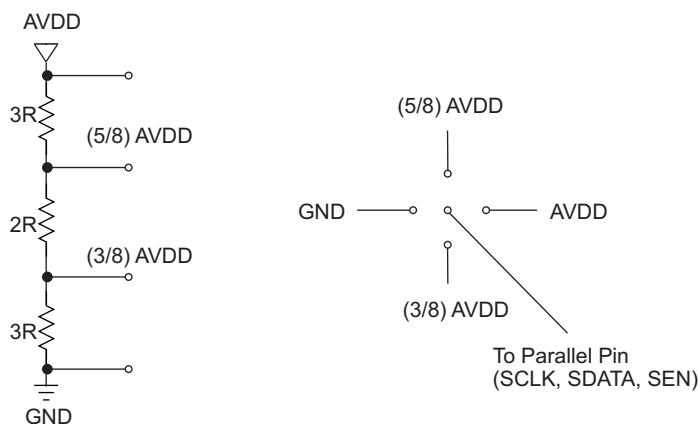

Figure 4. Simple Scheme to Configure Parallel Pins

DESCRIPTION OF PARALLEL PINS

Table 2. SCLK Control Pin

SCLK	DESCRIPTION
0	Internal reference and 0 dB gain (Full-scale = 2 V _{PP})
(3/8) AVDD	External reference and 0 dB gain (Full-scale = 2 V _{PP})
(5/8) AVDD	External reference and 3.5 dB coarse gain (Full-scale = 1.34 V _{PP})
AVDD	Internal reference and 3.5 dB coarse gain (Full-scale = 1.34 V _{PP})

Table 3. SEN Control Pin

SEN	DESCRIPTION
0	2s Complement format and DDR LVDS interface
(3/8) AVDD	Straight binary format and DDR LVDS interface
(5/8) AVDD	Straight binary and parallel CMOS interface
AVDD	2s Complement format and parallel CMOS interface

Table 4. SDATA, PDN Control Pins

SDATA	PDN	DESCRIPTION
Low	Low	Normal operation
Low	High (AVDD)	Standby - only the ADC is powered down
High (AVDD)	Low	Output buffers are powered down, fast wake-up time
High (AVDD)	High (AVDD)	Global power down. ADC, internal reference and output buffers are powered down, slow wake-up time

SERIAL INTERFACE

The ADC has a set of internal registers, which can be accessed through the serial interface formed by pins SEN (Serial interface Enable), SCLK (Serial Interface Clock), SDATA (Serial Interface Data) and RESET. After device start, the internal registers must be reset to the default values by applying a high-going pulse on RESET (width greater than 10 ns).

Serial shift of bits into the device is enabled when SEN is low. Serial data SDATA is latched at every falling edge of SCLK when SEN is active (low). The serial data is loaded into the register at every 16th SCLK falling edge when SEN is low. If the word length exceeds a multiple of 16 bits, the excess bits are ignored. Data is loaded in multiples of 16-bit words within a single active SEN pulse.

The first 5 bits form the register address and the remaining 11 bits form the register data.

The interface can work with SCLK frequency from 20 MHz down to very low speeds (few Hertz) and also with non-50% SCLK duty cycle.

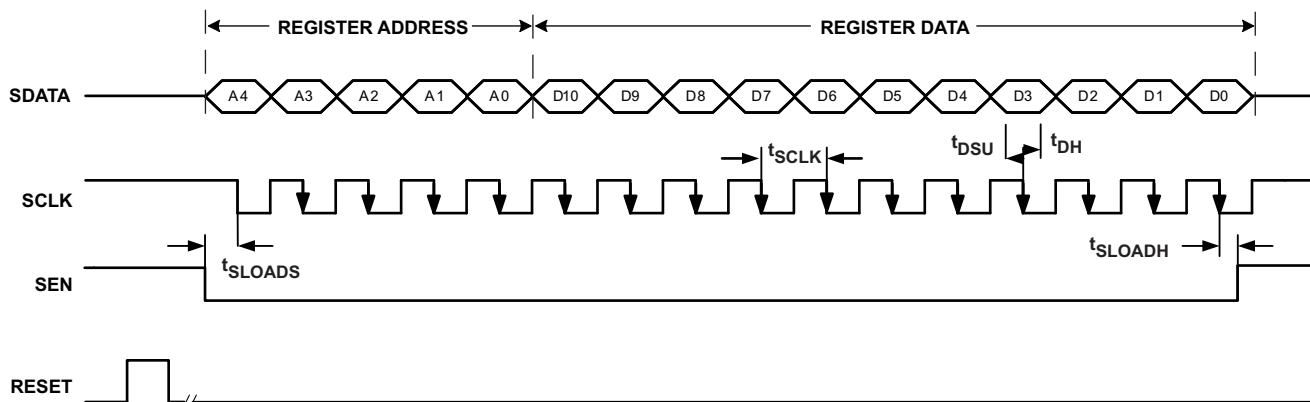

Figure 5. Serial Interface Timing Diagram

REGISTER INITIALIZATION

After power application, internal registers *must* be reset to the default values. This is done using one of these methods:

1. Use a hardware reset by applying a high-going pulse on RESET pin (of width greater than 10 ns) as shown in [Figure 5](#).

or

2. Apply a software reset. Using the serial interface, set the <RST> bit (D4 in register 0x00) to **high**. This initializes the internal registers to their default values and then self-resets the <RST> bit to **low**. In this case the RESET pin is kept **low**.

SERIAL INTERFACE TIMING

Typical values at 25°C, min and max values across the full temperature range $T_{MIN} = -40^{\circ}C$ to $T_{MAX} = 85^{\circ}C$, AVDD = 3.0 to 3.6V, DRVDD = 1.65 to 3.6V (unless otherwise noted)

		MIN	TYP	MAX	UNIT
f_{SCLK}	SCLK Frequency = $1/t_{SCLK}$	> DC		20	MHz
t_{SLOADS}	SEN to SCLK Setup time	25			ns
t_{SLOADH}	SCLK to SEN Hold time	25			ns
t_{DSU}	SDATA Setup time	25			ns
t_{DH}	SDATA Hold time	25			ns

RESET TIMING

Typical values at 25°C, min and max values across the full temperature range $T_{MIN} = -40^{\circ}C$ to $T_{MAX} = 85^{\circ}C$, AVDD = 3.0 to 3.6V, DRVDD = 1.65 to 3.6V (unless otherwise noted)

PARAMETER	TEST CONDITIONS	MIN	TYP	MAX	UNIT
t_1	Power-on delay Delay from power-up of AVDD and DRVDD to RESET pulse active	5			ms
t_2	Reset pulse width Pulse width of active RESET signal	10			ns
t_3	Register write delay Delay from RESET disable to SEN active	25			ns
t_{PO}	Power-up time Delay from power-up of AVDD and DRVDD to output stable		6.5		ms

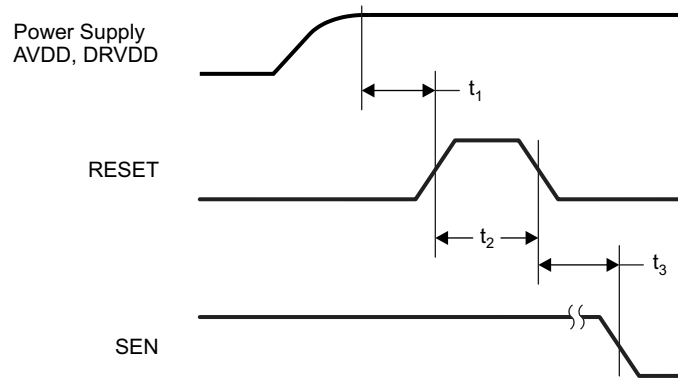

NOTE: A high-going pulse on RESET pin is required in serial interface mode in case of initialization through hardware reset. For parallel interface operation, RESET has to be tied permanently HIGH.

Figure 6. Reset Timing Diagram

SERIAL REGISTER MAP

Table 5 provides a summary of all the modes that can be programmed through the serial interface.

Table 5. Summary of Functions Supported by Serial Interface⁽¹⁾⁽²⁾

REGISTER ADDRESS IN HEX	REGISTER FUNCTIONS										
	A4 - A0	D10	D9	D8	D7	D6	D5	D4	D3	D2	D1
00	<PDN OBUF> Output buffers powered down	<COARSE GAIN> Coarse gain	<LVDS CMOS> LVDS or CMOS output interface	0	0	<REF> Internal or external Reference	<RST> Software Reset	0	<PDN CLKOUT> Output clock buffer powered down	0	<STBY> ADC Power down
04	<DATAOUT POSN> Output data position control	<CLKOUT EDGE> Output Clock edge control	<CLKOUT POSN> Output Clock position control	0	0	0	0	0	0	0	0
09	Bit-wise or Byte-wise control	0	0	0	0	0	0	0	0	0	0
0A	<DATA FORMAT> 2s complement or straight binary	0	0	<TEST PATTERNS>			0	0	0	0	0
0B	<CUSTOM LOW> Custom Pattern lower 7bits							0	0	0	0
0C	<FINE GAIN> Fine Gain 0 to 6dB				0	0	0	<CUSTOM HIGH> Custom Pattern upper 5 bits			
0E	0	LVDS Termination LVDS Internal Termination control for output data and clock						<LVDS CURRENT> LVDS Current control		<CURRENT DOUBLE> LVDS current double	
0F	0	0	0	<DRIVE STRENGTH> CMOS output buffer drive strength control				0	0	0	0

- (1) The unused bits in each register (shown by blank cells in above table) must be programmed as '0'.
(2) Multiple functions in a register can be programmed in a single write operation.

DESCRIPTION OF SERIAL REGISTERS

Each register function is explained in detail using [Table 6](#) through [Table 13](#).

Table 6.

A4–A0 (hex)	D10	D9	D8	D7	D6	D5	D4	D3	D2	D1	D0
00	<PDN OBUF> Output buffers powered down	<COARSE GAIN> Coarse gain	<LVDS CMOS> LVDS or CMOS output interface	0	0	<REF> Internal or external reference	<RST> Software Reset	0	<PDN CLKOUT> Output clock buffer powered down	0	<STBY> ADC Power down

D0 <STBY> [Power down modes](#)

- 0 Normal operation
- 1 Device enters standby mode where only ADC is powered down.

D2 <PDN CLKOUT>

- 0 Output clock is active (on CLKOUT) pin
- 1 Output clock buffer is powered down and becomes tri-stated. Data outputs are unaffected.

D4 <RST>

- 1 Software reset applied - resets all internal registers and the bit self-clears to 0.

D5 <REF> [Reference selection](#)

- 0 Internal reference enabled
- 1 External reference enabled

D8 <LVDS CMOS> [Output Interface selection](#)

- 0 Parallel CMOS interface
- 1 DDR LVDS interface

D9 <COARSE GAIN> [Gain programming](#)

- 0 0 dB Coarse gain
- 1 3.5 dB Coarse gain

D10 <PDN OBUF> [Power down modes](#)

- 0 Output data and clock buffers enabled
- 1 Output data and clock buffers disabled

Table 7.

A4–A0 (hex)	D10	D9	D8	D7	D6	D5	D4	D3	D2	D1	D0
04	<DATAOUT POSN> Output data position control	<CLKOUT EDGE> Output Clock edge control	<CLKOUT POSN> Output Clock position control	0	0	0	0	0	0	0	0

D8 <CLKOUT POSN> [Output clock position control](#)

- 0 Default output clock position after reset. The setup/hold timings for this clock position are specified in the timing specifications table.
- 1 Output clock shifted (delayed) by 400 ps

D9 <CLKOUT EDGE>

- 0 Use rising edge to capture data
- 1 Use falling edge to capture data

D10 <DATAOUT_POSN>

- 0 Default position (after reset)
- 1 Data transition delayed by half clock cycle with respect to default position

Table 8.

A4–A0 (hex)	D10	D9	D8	D7	D6	D5	D4	D3	D2	D1	D0
09	Bit-wise or Byte-wise control	0	0	0	0	0	0	0	0	0	0

D10 **Bit-wise or byte-wise selection (DDR LVDS mode only)**

- 0 Bit-wise sequence - Even data bits (D0, D2, D4..D12) are output at rising edge of CLKOUTP and odd data bits (D1, D3, D5..D13) at falling edge of CLKOUTP
- 1 Byte-wise sequence - Lower 7 data bits (D0-D7) are output at rising edge of CLKOUTP and upper 7 data bits (D8-D13) at falling edge of CLKOUTP

Table 9.

A4–A0 (hex)	D10	D9	D8	D7	D6	D5	D4	D3	D2	D1	D0
0A	<DF> 2s complement or straight binary	0	0	<TEST PATTERNS>			0	0	0	0	0

D7-D5 Test Patterns

- 000 Normal operation - <D11:D0> = ADC output
- 001 All zeros - <D11:D0> = 0x000
- 010 All ones - <D11:D0> = 0xFFFF
- 011 Toggle pattern - <D11:D0> toggles between 0xAAA and 0x555
- 100 Digital ramp - <D11:D0> increments from 0x000 to 0xFFFF by one code every cycle
- 101 Custom pattern - <D11:D0> = contents of CUSTOM PATTERN registers
- 110 Unused
- 111 Unused

D10 <DATA FORMAT>

- 0 2s Complement
- 1 Straight binary

Table 10.

A4–A0 (hex)	D10	D9	D8	D7	D6	D5	D4	D3	D2	D1	D0
0B	<CUSTOM LOW> Lower 7bits of custom pattern							0	0	0	0

Table 11.

A4–A0 (hex)	D10	D9	D8	D7	D6	D5	D4	D3	D2	D1	D0
0C	<FINE GAIN> Fine Gain 0 to 6dB			0	0	0	<CUSTOM HIGH> Upper 5 bits of custom pattern				

Reg 0B <CUSTOM LOW> - Specifies lower 7 bits of custom pattern
D10-D4

Reg 0C <CUSTOM HIGH> - Specifies upper 5 bits of custom pattern
D4-D0

D10-D8 <FINE GAIN> [Gain programming](#)

- 000 0 dB Gain
- 001 1 dB Gain
- 010 2 dB Gain
- 011 3 dB Gain
- 100 4 dB Gain
- 101 5 dB Gain
- 110 6 dB Gain
- 111 Unused

Table 12.

A4–A0 (hex)	D10	D9	D8	D7	D6	D5	D4	D3	D2	D1	D0
0E	0	<LVDS TERMINATION> LVDS Internal Termination control for output data and clock						<LVDS CURRENT> LVDS Current control		<CURRENT DOUBLE> LVDS current double	

D1-D0 <CURRENT DOUBLE> [LVDS current programming](#)

D0 LVDS Data buffer current control

- | | |
|---|-------------------------------------|
| 0 | Default current, set by <LVDS_CURR> |
| 1 | 2x LVDS Current set by <LVDS_CURR> |

D1 LVDS Clock buffer current control

- | | |
|---|-------------------------------------|
| 0 | Default current, set by <LVDS_CURR> |
| 1 | 2x LVDS Current set by <LVDS_CURR> |

D3-D2 <LVDS CURRENT> [LVDS current programming](#)

- | | |
|----|---------|
| 00 | 3.5 mA |
| 01 | 2.5 mA |
| 10 | 4.5 mA |
| 11 | 1.75 mA |

D9-D4 [LVDS internal termination](#)

D9-D7 <DATA TERM> Internal termination for LVDS output data bits

- | | |
|-----|-------------------------|
| 000 | No internal termination |
| 001 | 300 Ω |
| 010 | 185 Ω |
| 011 | 115 Ω |
| 100 | 150 Ω |
| 101 | 100 Ω |
| 110 | 80 Ω |
| 111 | 65 Ω |

D6-D4 <CLKOUT TERM> Internal termination for LVDS output clock

- | | |
|-----|-------------------------|
| 000 | No internal termination |
| 001 | 300 Ω |
| 010 | 185 Ω |
| 011 | 115 Ω |
| 100 | 150 Ω |
| 101 | 100 Ω |
| 110 | 80 Ω |
| 111 | 65 Ω |

Table 13.

A4-A0 (hex)	D10	D9	D8	D7	D6	D5	D4	D3	D2	D1	D0
0F	0	0	0	<DRIVE STRENGTH> CMOS output buffer drive strength control				0	0	0	0

D7-D4 <DRIVE STRENGTH> [Output buffer drive strength controls](#)

- 0101 WEAKER than default drive
- 0000 DEFAULT drive strength
- 1111 STRONGER than default drive strength (recommended for load capacitances > 5 pF)
- 1010 MAXIMUM drive strength (recommended for load capacitances > 5 pF)
- Other Do not use combinations

PIN CONFIGURATION (CMOS MODE)

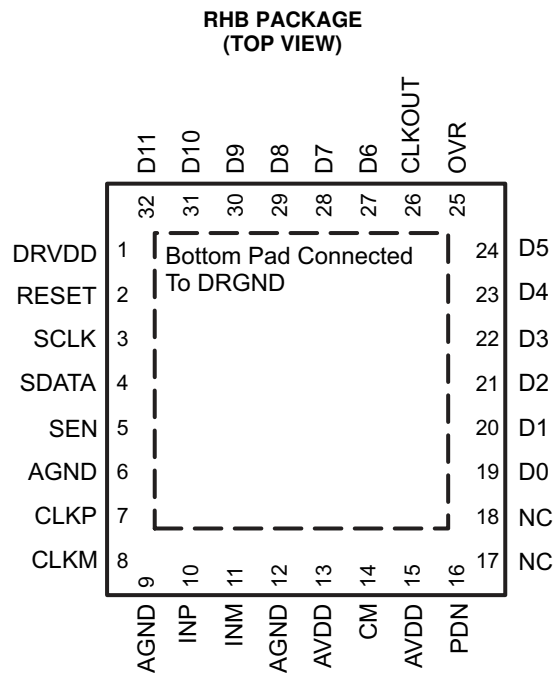

Figure 7. CMOS Mode Pinout

Table 14. Pin Assignments – CMOS Mode

PIN NAME	DESCRIPTION	PIN TYPE	PIN NUMBER	NUMBER OF PINS
AVDD	Analog power supply	I	13, 15	2
AGND	Analog ground	I	6, 9, 12	3
CLKP, CLKM	Differential clock input	I	7, 8	2
INP, INM	Differential analog input. On each pin, a 2.3 V common-mode voltage is set internally.	I	10, 11	2
VCM	Internal reference mode – 1.5 V voltage output. Do NOT use this pin to set the common-mode on the analog input pins. External reference mode – reference input. The voltage forced on this pin sets the internal references.	I/O	14	1
RESET	Serial interface RESET input. When using the serial interface mode, the user MUST initialize internal registers through hardware RESET by applying a high-going pulse on this pin, or by using the software reset option. See the <i>SERIAL INTERFACE</i> section. In parallel interface mode, the user has to tie the RESET pin permanently HIGH. (SCLK, SDATA and SEN are used as parallel pin controls in this mode) The pin has an internal 100-k Ω pull-down resistor.	I	2	1
SCLK	This pin functions as serial interface clock input when RESET is low. When RESET is tied high, it controls the coarse gain and internal/external reference selection. Tie SCLK to low for internal reference and 0 dB gain and high for internal reference and 3.5 dB gain. See Table 2 . The pin has an internal 100 k Ω pull-down resistor.	I	3	1
SDATA	This pin functions as serial interface data input when RESET is low . It controls various power down modes along with PDN pin when RESET is tied high . See Table 4 for detailed information. The pin has an internal 100 k Ω pull-down resistor.	I	4	1
SEN	This pin functions as serial interface enable input when RESET is low . When RESET is high, it controls output interface type and data formats. See Table 3 for detailed information. The pin has an internal 100 k Ω pull-up resistor to DRVDD.	I	5	1

Table 14. Pin Assignments – CMOS Mode (continued)

PIN NAME	DESCRIPTION	PIN TYPE	PIN NUMBER	NUMBER OF PINS
PDN	Global power down control pin	I	16	1
CLKOUT	CMOS Output clock	O	26	1
D0	CMOS Output data D0	O	19	1
D1	CMOS Output data D1	O	20	1
D2	CMOS Output data D2	O	21	1
D3	CMOS Output data D3	O	22	1
D4	CMOS Output data D4	O	23	1
D5	CMOS Output data D5	O	24	1
D6	CMOS Output data D6	O	27	1
D7	CMOS Output data D7	O	28	1
D8	CMOS Output data D8	O	29	1
D9	CMOS Output data D9	O	30	1
D10	CMOS Output data D10	O	31	1
D11	CMOS Output data D11	O	32	1
OVR	Indicates over-voltage on analog inputs (for differential input greater than full-scale), CMOS level	O	25	1
DRVDD	Digital supply	I	1	1
DRGND	Digital ground. Connect the pad to the ground plane. See Board Design Considerations in application information section.	I	PAD	1

PIN CONFIGURATION (LVDS MODE)

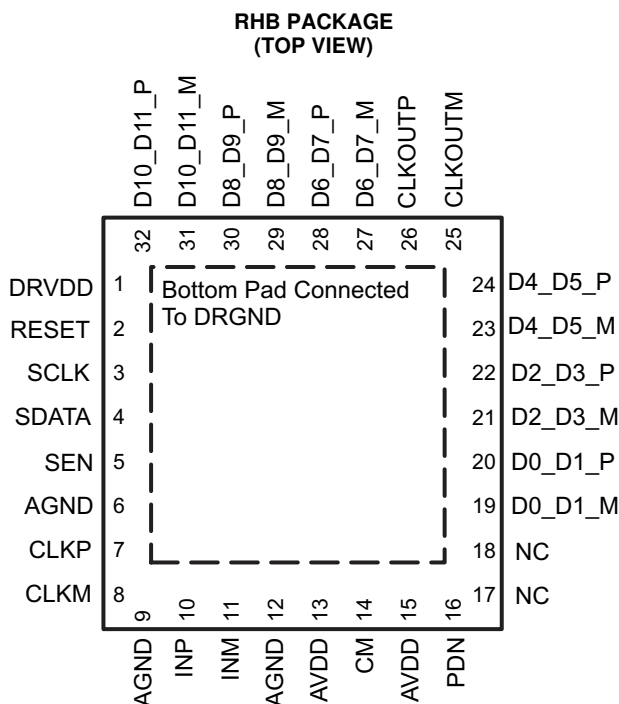

Figure 8. LVDS Mode Pinout

Table 15. Pin Assignments – LVDS Mode

PIN NAME	DESCRIPTION	PIN TYPE	PIN NUMBER	NUMBER OF PINS
AVDD	Analog power supply	I	13, 15	2
AGND	Analog ground	I	6, 12	3
CLKP, CLKM	Differential clock input	I	7, 8	2
INP, INM	Differential analog input	I	10, 11	2
VCM	Internal reference mode – 1.5V voltage output. Do NOT use this pin to set the common-mode on the analog input pins. External reference mode – reference input. The voltage forced on this pin sets the internal references.	I/O	14	1
RESET	Serial interface RESET input. When using the serial interface mode, the user MUST initialize internal registers through hardware RESET by applying a high-going pulse on this pin, or by using the software reset option. See the <i>SERIAL INTERFACE</i> section. In parallel interface mode, the user has to tie the RESET pin permanently HIGH. (SCLK, SDATA and SEN are used as parallel pin controls in this mode) The pin has an internal 100-kΩ pull-down resistor.	I	2	1
SCLK	This pin functions as serial interface clock input when RESET is low. When RESET is tied high, it controls the coarse gain and internal/external reference selection. Tie SCLK to low for internal reference and 0 dB gain and high for internal reference and 3.5 dB gain. See Table 2 . The pin has an internal 100-kΩ pull-down resistor.	I	3	1
SDATA	This pin functions as serial interface data input when RESET is low . It controls various power down modes along with PDN pin when RESET is tied high . See Table 4 for detailed information. The pin has an internal 100 kΩ pull-down resistor.	I	4	1
SEN	This pin functions as serial interface enable input when RESET is low . When RESET is high, it controls output interface type and data formats. See Table 3 for detailed information. The pin has an internal 100-kΩ pull-up resistor to DRVDD.	I	5	1

Table 15. Pin Assignments – LVDS Mode (continued)

PIN NAME	DESCRIPTION	PIN TYPE	PIN NUMBER	NUMBER OF PINS
PDN	Global power down control pin	I	16	1
CLKOUTP	Differential output clock, true	O	26	1
CLKOUTM	Differential output clock, complement	O	25	1
D0_D1_P	Differential output data D0 and D1 multiplexed, true	O	20	1
D0_D1_M	Differential output data D0 and D1 multiplexed, complement.	O	19	1
D2_D3_P	Differential output data D2 and D3 multiplexed, true	O	22	1
D2_D3_M	Differential output data D2 and D3 multiplexed, complement	O	21	1
D4_D5_P	Differential output data D4 and D5 multiplexed, true	O	24	1
D4_D5_M	Differential output data D4 and D5 multiplexed, complement	O	23	1
D6_D7_P	Differential output data D6 and D7 multiplexed, true	O	28	1
D6_D7_M	Differential output data D6 and D7 multiplexed, complement	O	27	1
D8_D9_P	Differential output data D8 and D9 multiplexed, true	O	30	1
D8_D9_M	Differential output data D8 and D9 multiplexed, complement	O	29	1
D10_D11_P	Differential output data D10 and D11 multiplexed, true	O	32	1
D10_D11_M	Differential output data D10 and D11 multiplexed, complement	O	31	1
DRVDD	Digital supply	I	1	1
DRGND	Digital ground. Connect the pad to the ground plane. See <i>Board Design Considerations</i> in application information section.	I	PAD	1

TYPICAL CHARACTERISTICS

All plots are at 25°C, AVDD = DRVDD = 3.3 V, sampling frequency = 80 MSPS, sine wave input clock, 1.5 V_{PP} differential clock amplitude, 50% clock duty cycle, -1 dBFS differential analog input (1.8 V_{pp}), internal reference mode, 0 dB gain, unless otherwise noted.

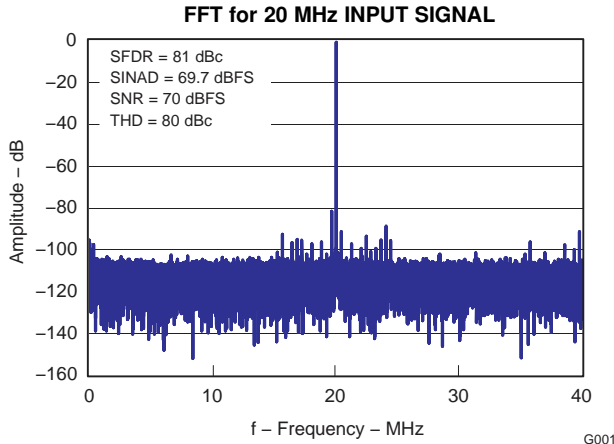

Figure 9.

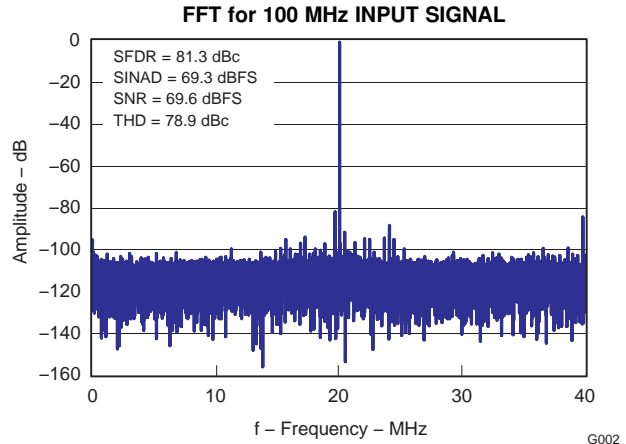

Figure 10.

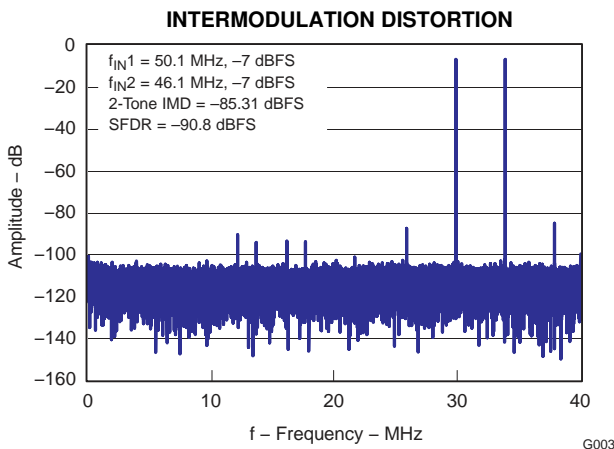

Figure 11.

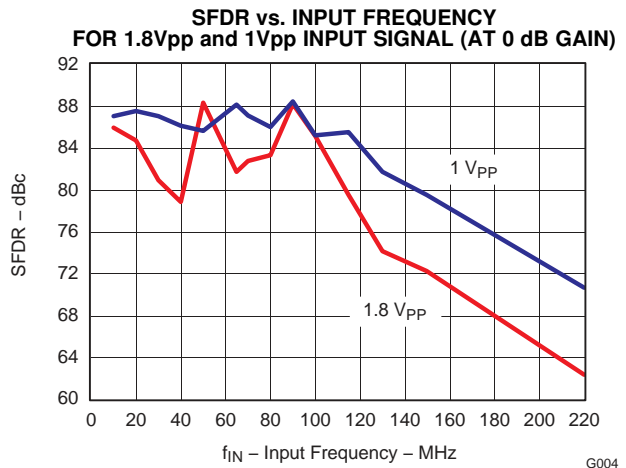

Figure 12.

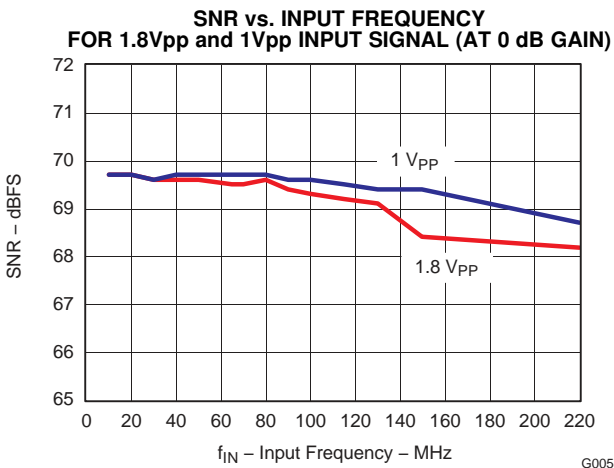

Figure 13.

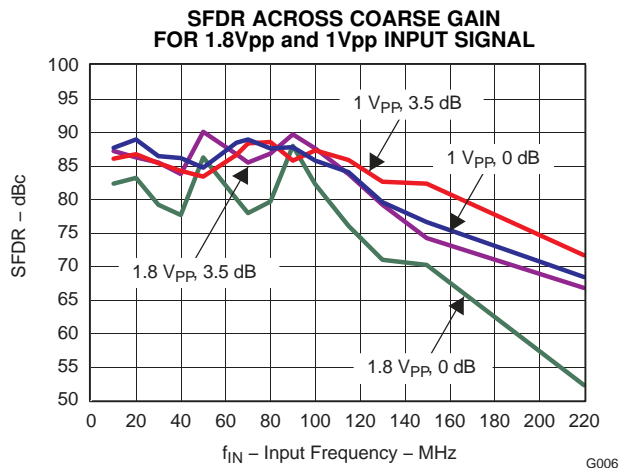

Figure 14.

TYPICAL CHARACTERISTICS (continued)

All plots are at 25°C, AVDD = DRVDD = 3.3 V, sampling frequency = 80 MSPS, sine wave input clock, 1.5 V_{PP} differential clock amplitude, 50% clock duty cycle, -1 dBFS differential analog input (1.8 V_{pp}), internal reference mode, 0 dB gain, unless otherwise noted.

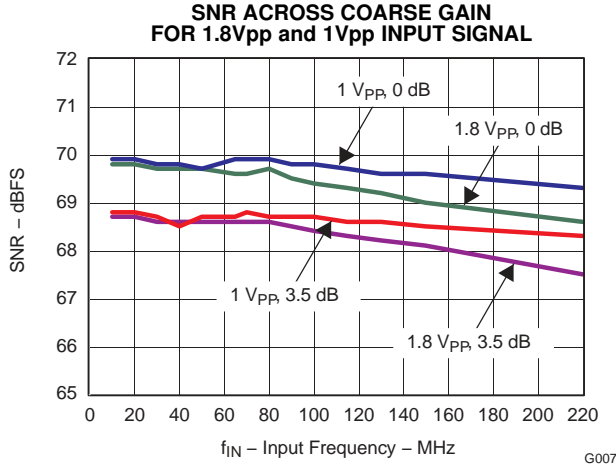

Figure 15.

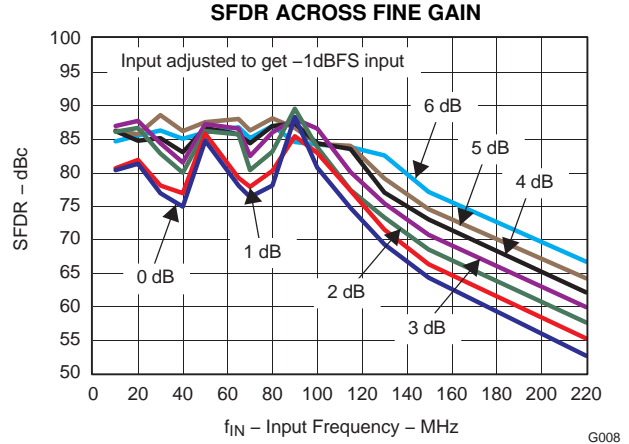

Figure 16.

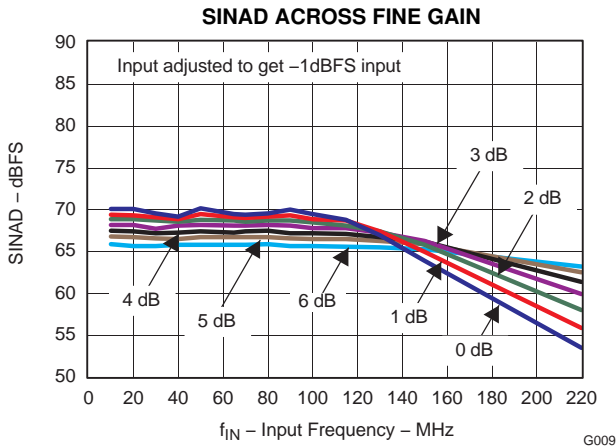

Figure 17.

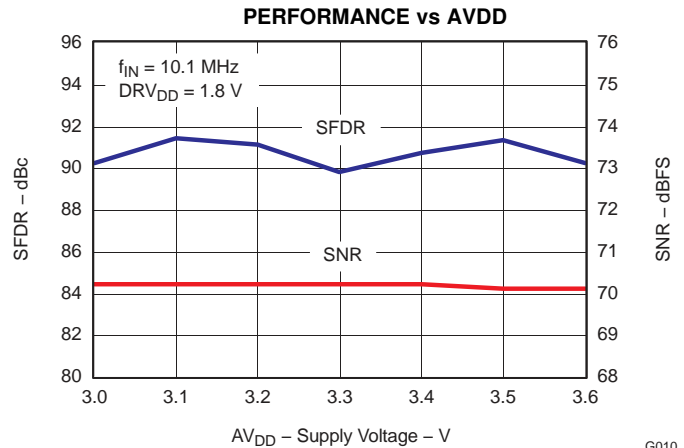

Figure 18.

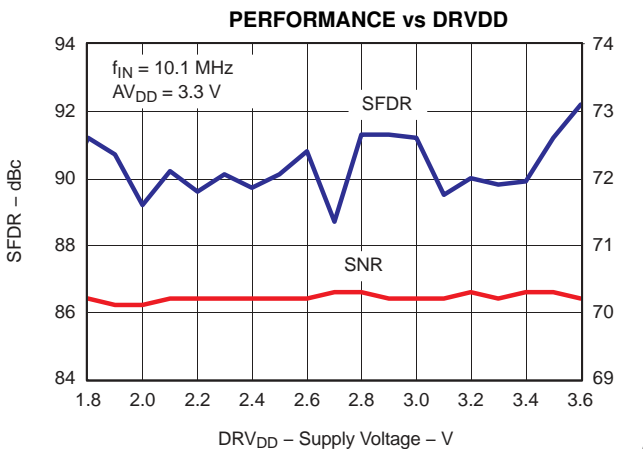

Figure 19.

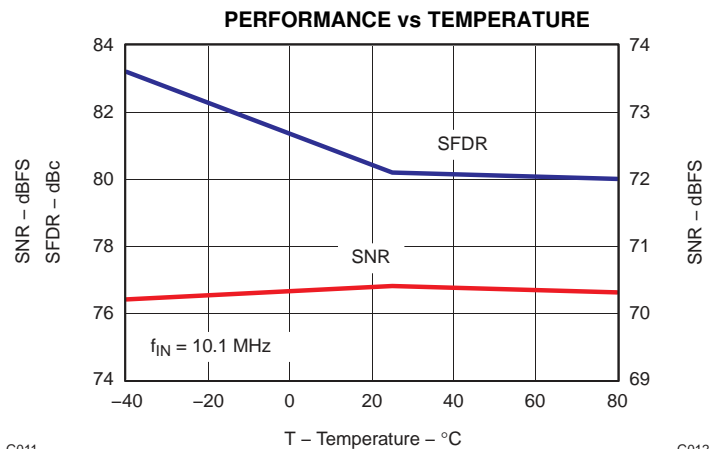

Figure 20.

TYPICAL CHARACTERISTICS (continued)

All plots are at 25°C, AVDD = DRVDD = 3.3 V, sampling frequency = 80 MSPS, sine wave input clock, 1.5 V_{PP} differential clock amplitude, 50% clock duty cycle, -1 dBFS differential analog input (1.8 V_{pp}), internal reference mode, 0 dB gain, unless otherwise noted.

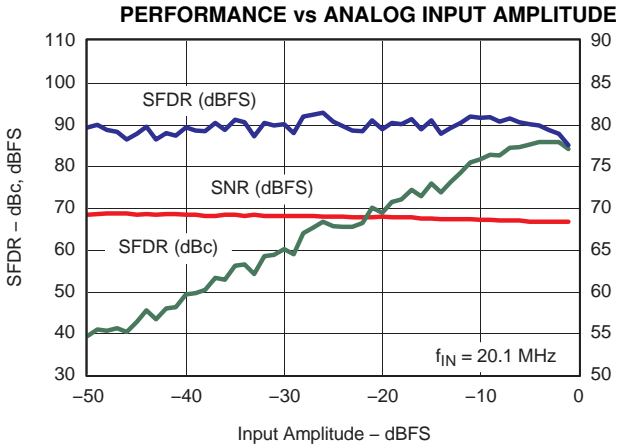

Figure 21.

G013

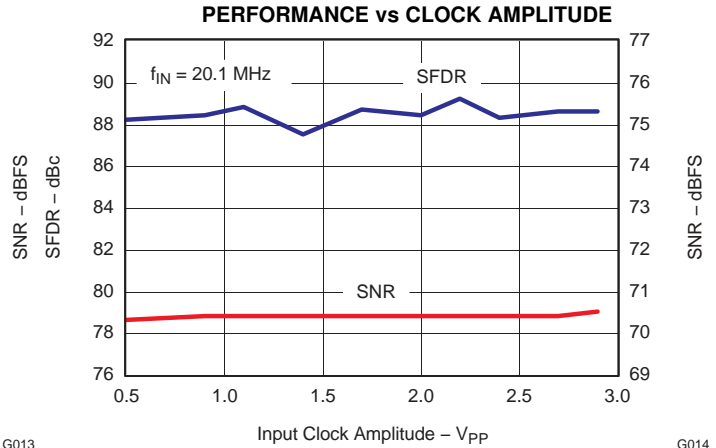

Figure 22.

G014

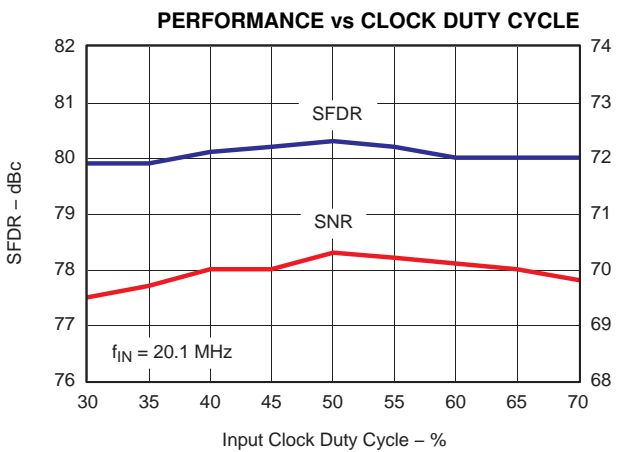

Figure 23.

G015

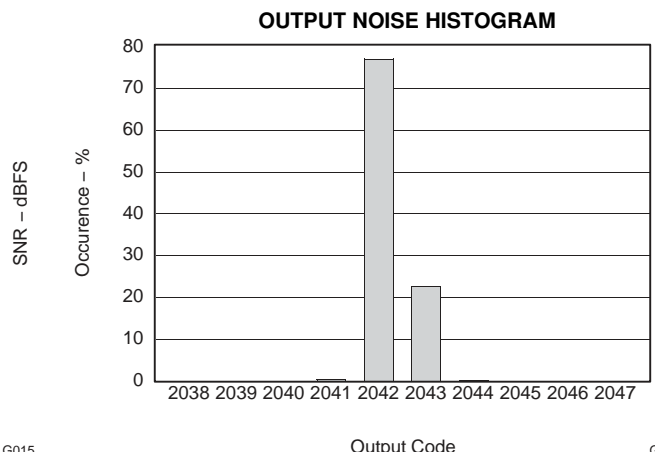

Figure 24.

G016

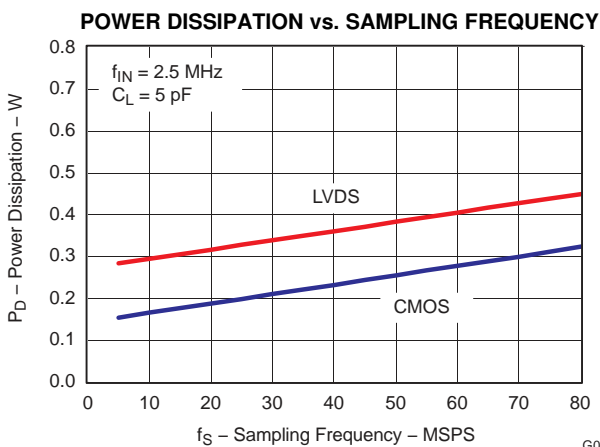

Figure 25.

G017

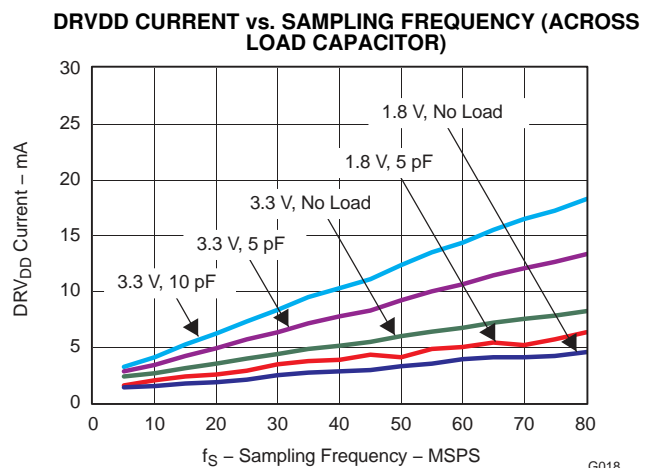

Figure 26.

G018

TYPICAL CHARACTERISTICS - AT LOWER SAMPLING FREQUENCIES

All plots are at 25°C, AVDD = DRVDD = 3.3 V, sine wave input clock, 1.5 V_{PP} differential clock amplitude, 50% clock duty cycle, -1 dBFS differential analog input (1.8V_{pp}) , internal reference mode, 0 dB gain, unless otherwise noted.

F_S = 65 MSPS

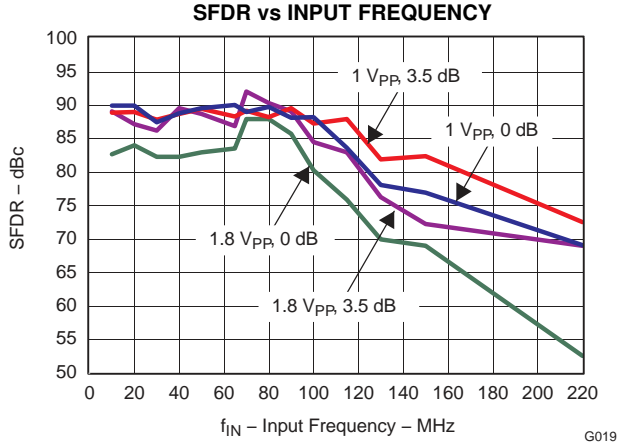

Figure 27.

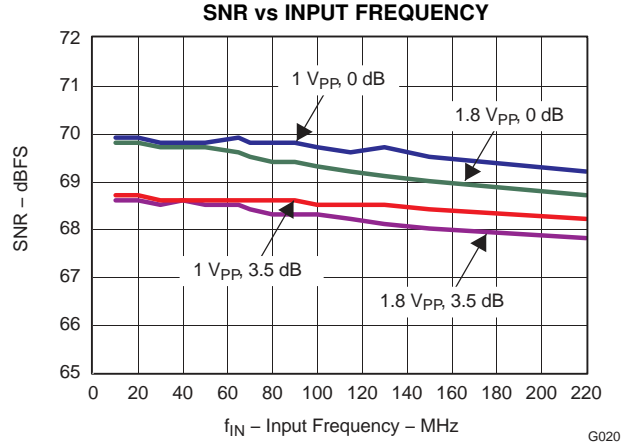

Figure 28.

F_S = 40 MSPS

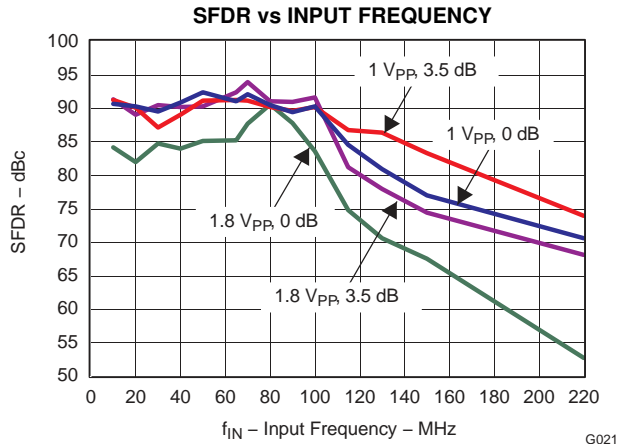

Figure 29.

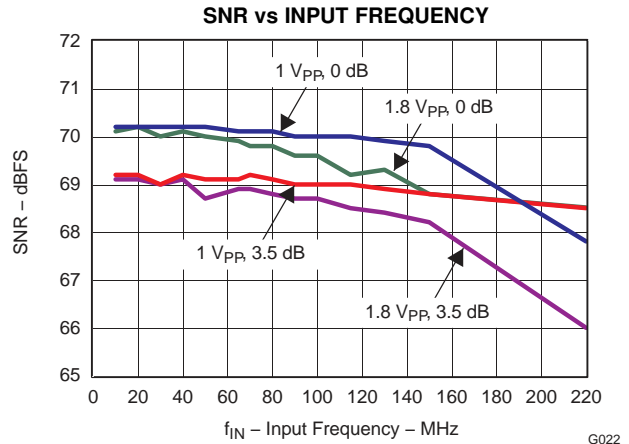

Figure 30.

APPLICATION INFORMATION

THEORY OF OPERATION

ADS61B23 is a low-power, 12-bit pipeline ADC (CMOS process) with a maximum 80 MSPS sampling frequency. It is based on switched capacitor technology and runs off a single 3.3-V supply. The conversion process is initiated by a rising edge of the external input clock. Once the signal is captured by the input sample and hold, the input sample is sequentially converted by a series of lower resolution stages, with the outputs combined in a digital correction logic block. At every clock edge, the sample propagates through the pipeline resulting in a data latency of 9 clock cycles. The output is available as 12-bit data, in DDR LVDS or CMOS and coded in straight offset binary or binary 2s complement format.

ANALOG INPUT

The analog input consists of an internal analog buffer followed by the sample and hold circuit, shown in Figure 31.

The buffer isolates the external drive circuit from the switching transients of the sample and hold. The buffered inputs present very low input capacitance ($< 2\text{pF}$) & wide bandwidth. This makes it easy to drive them even at high input frequencies, compared to an ADC without the input buffers. The input common-mode is set internally by a $5\text{ k}\Omega$ resistor from each input pin to an internally generated common-mode voltage (2.3 V). This results in a differential resistance of $\text{k}\Omega$.

For a full-scale differential input, each input pin INP, INM swings symmetrically between $(2.3 + 0.5\text{ V})$ and $(2.3 - 0.5\text{ V})$, resulting in a 2 V_{PP} differential input swing. The maximum swing is determined by the internal reference voltages REFP (2.0 V , nominal) and REFM (1.0 V , nominal).

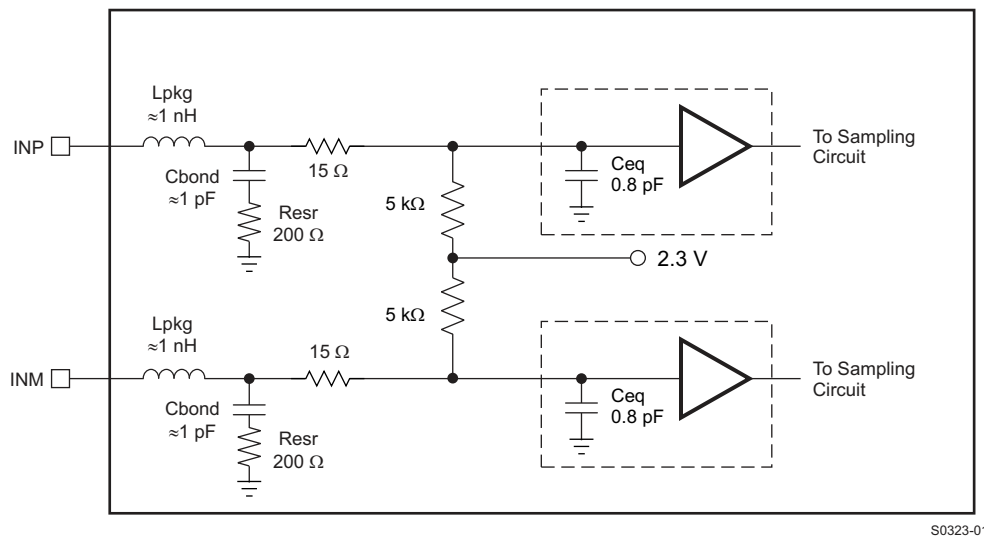

Figure 31. Input Stage

As shown by Figure 31, the equivalent input capacitance from each input pin to ground is very low ($< 2\text{pF}$), resulting in high analog input bandwidth ($> 800\text{ MHz}$).

Drive Circuit Requirements

For optimum performance, the analog inputs must be driven differentially. This improves the common-mode noise immunity and even order harmonic rejection. A 5 Ω resistor in series with each input pin is recommended to damp out ringing caused by the package parasitic effects. Since the common-mode of each input pin is set internally by the device, it is recommended to ac-couple the analog input signal.

The input impedance of each pin can be approximated by a 5 kΩ resistor in parallel with 1.8 pF capacitor and presents high impedance over wide frequency range. The low input capacitance and wide input bandwidth makes it easy to design the external drive circuit with low insertion loss.

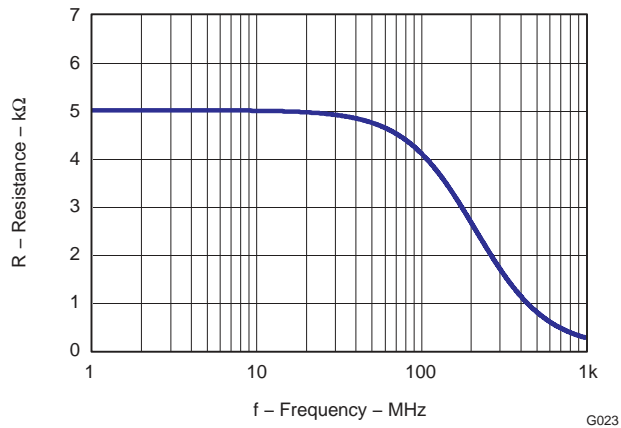

Figure 32. ADC Input Resistance, Rin

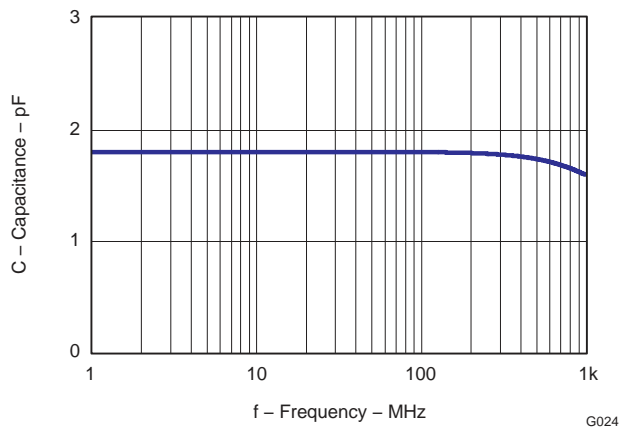
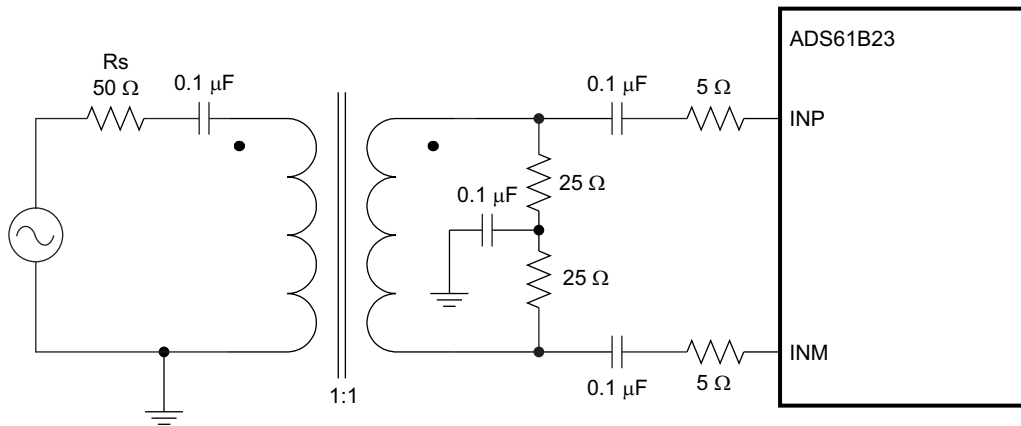

Figure 33. ADC Input Capacitance, Cin

Using RF-Transformer Based Drive Circuits

Figure 34 shows a drive circuit using a single 1:1 turns ratio transformer (for example, Coilcraft WBC1-1) that can be used for low input frequencies (≈ 100 MHz).

The single-ended signal is fed to the primary winding of the RF transformer with 50- Ω termination on the secondary side.



S0256-02

Figure 34. Single Transformer Drive Circuit

At high input frequencies, the mismatch in the transformer parasitic capacitance (between the windings) results in degraded even-order harmonic performance. Connecting two identical RF transformers back-to-back helps minimize this mismatch, and good performance is obtained for high frequency input signals. Figure 35 shows an example using two transformers (Coilcraft WBC1-1). An additional termination resistor pair (enclosed within the shaded box in Figure 35) may be required between the two transformers to improve the balance between the P and M sides. The center point of this termination must be connected to ground.

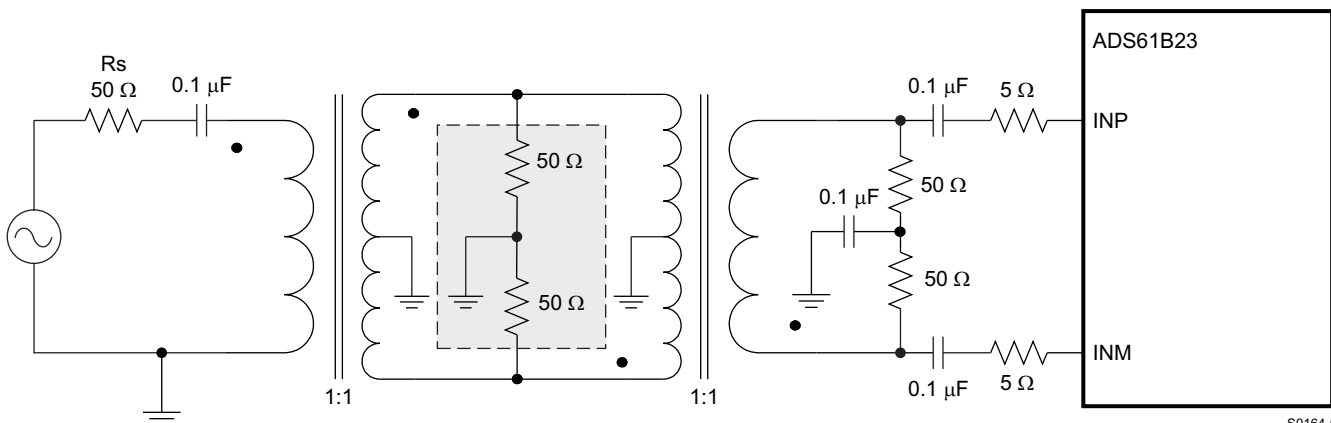

S0164-06

Figure 35. Two Transformer Drive Circuit

Using Differential Amplifier Drive Circuits

Figure 36 shows a drive circuit using a differential amplifier (TI's THS4509) to convert a single-ended input to differential output that can be interface to the ADC analog input pins. In addition to the single-ended to differential conversion, the amplifier also provides gain. R_{FIL} & C_{FIL} form a low-pass filter that band-limits the noise (and signal) at the ADC input.

Note that as the device sets the input common-mode voltage internally, the amplifier outputs can be ac-coupled to the analog input pins.

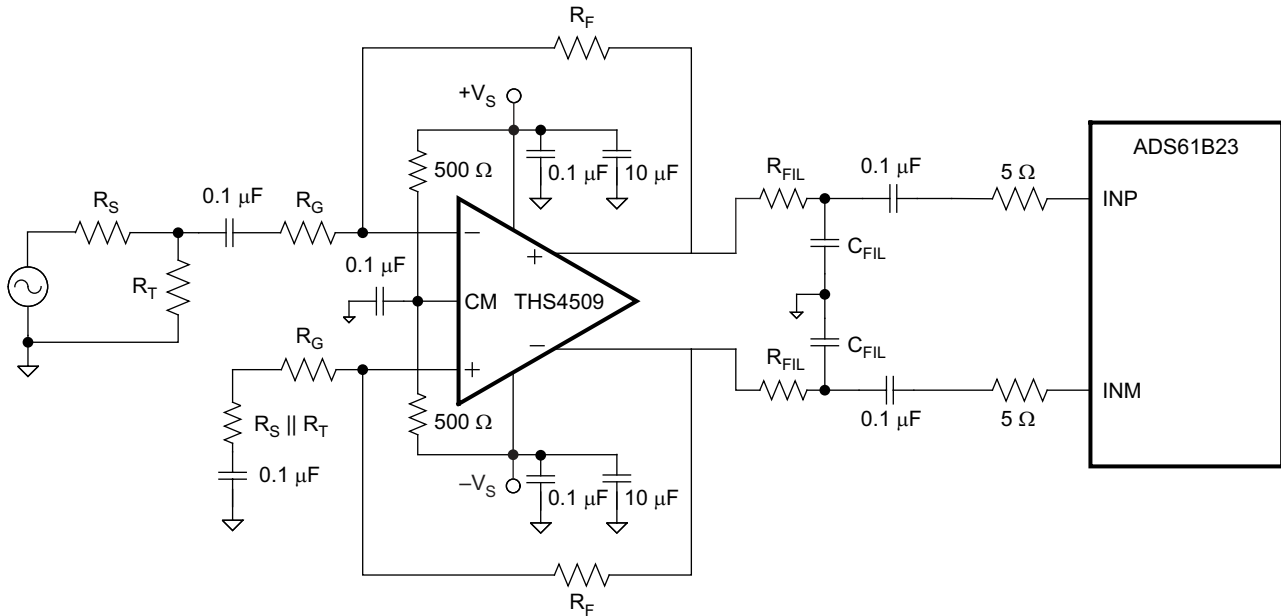

S0259-03

Figure 36. Drive Circuit Using the THS4509

See the *ADS61xx EVM User's Guide* (SLAU206) for more information.

REFERENCE

ADS61B23 has built-in internal references REFP and REFM, requiring no external components. Design schemes are used to linearize the converter load seen by the references; this and the integration of the requisite reference capacitors on-chip eliminates the need for external decoupling. The full-scale input range of the converter is controlled in the external reference mode as explained below. The internal or external reference modes can be selected by programming the serial interface register bit <REF> (see Table 6).

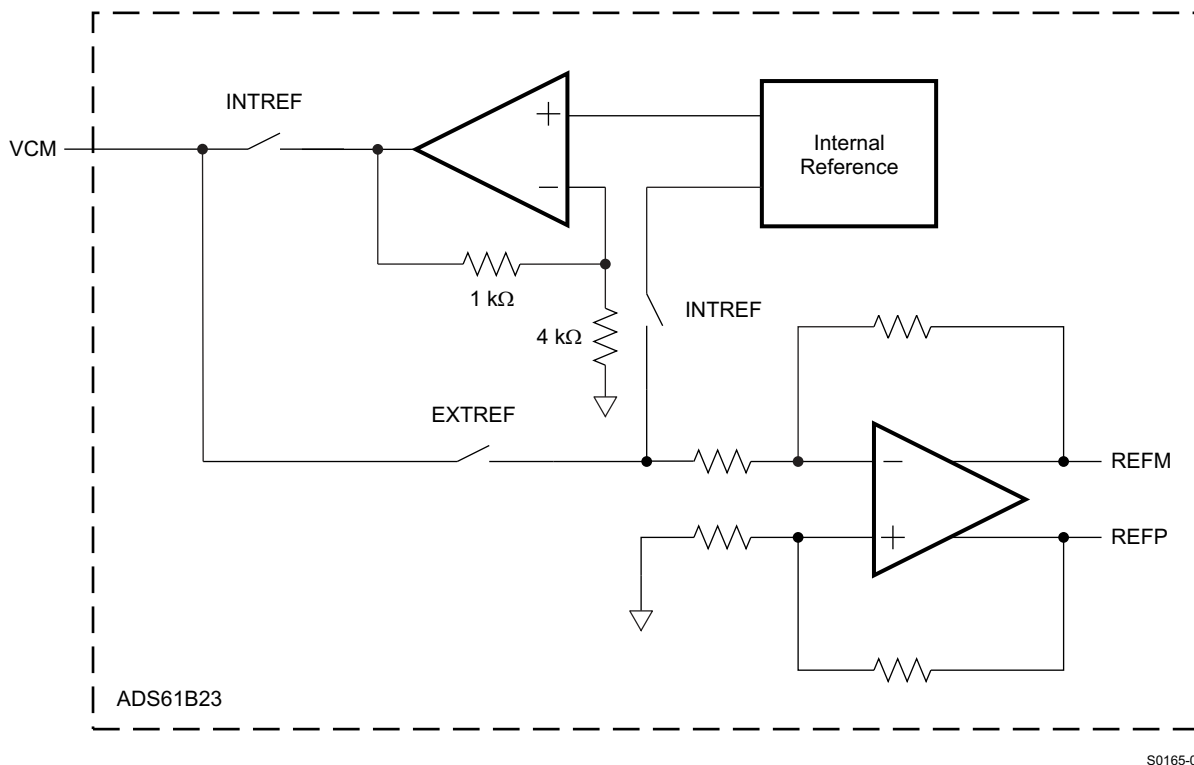

Figure 37. Reference Section

Internal Reference

When the device is in internal reference mode, the REFP and REFM voltages are generated internally. In this mode, a 1.5 V dc voltage is output on the VCM pin. *However, do not use this to set the common-mode of the analog input pins, as the common-mode on these pins is set internally to 2.3V.*

External Reference

When the device is in external reference mode, the VCM acts as a reference input pin. The voltage forced on the VCM pin is buffered and gained by 1.33 internally, generating the REFP and REFM voltages. The differential input voltage corresponding to full-scale is given by Equation 1.

$$\text{Full-scale differential input pp} = (\text{Voltage forced on VCM}) \times 1.33 \quad (1)$$

In this mode, the 1.5 V common-mode voltage to bias the input pins has to be generated externally. There is no change in performance compared to internal reference mode.

COARSE GAIN and PROGRAMMABLE FINE GAIN

ADS61B23 includes gain settings that can be used to get improved SFDR performance (compared to 0 dB gain mode). The gain settings are 3.5 dB coarse gain and programmable fine gain from 0 dB to 6 dB. For each gain setting, the analog input full-scale range scales proportionally, as shown in [Table 16](#).

The coarse gain is a fixed setting of 3.5 dB and is designed to improve SFDR with little degradation in SNR (as seen in [Figure 14](#) and [Figure 15](#)). The fine gain is programmable in 1 dB steps from 0 to 6 dB. With fine gain also, SFDR improvement is achieved, but at the expense of SNR (there is about 1 dB SNR degradation for every 1 dB of fine gain).

So, the fine gain can be used to trade-off between SFDR and SNR. The coarse gain makes it possible to get best SFDR, without losing significant SNR. At high input frequencies, the gains are especially useful as the SFDR improvement is significant with marginal degradation in SINAD. The gains can be programmed using the register bits <COARSE GAIN> (see [Table 6](#)) and <FINE GAIN> (see [Table 11](#)).

Note that the default gain after reset is 0 dB.

Table 16. Full-Scale Range Across Gains

GAIN, dB	TYPE	FULL-SCALE RANGE, V _{PP}
0	Default after reset	2.00
3.5	Coarse setting (fixed)	1.34
1	Fine gain (programmable)	1.78
2		1.59
3		1.42
4		1.26
5		1.12
6		1.00

CLOCK INPUT

The clock inputs of ADS61B23 can be driven differentially (SINE, LVPECL or LVDS) or single-ended (LVCMOS), with little or no difference in performance between configurations. The common-mode voltage of the clock inputs is set to VCM using internal 5-k Ω resistors as shown in Figure 38. This allows the use of transformer-coupled drive circuits for sine wave clock, or ac-coupling for LVPECL, LVDS clock sources (Figure 40 and Figure 41).

For best performance, it is recommended to drive the clock inputs differentially, reducing susceptibility to common-mode noise. In this case, it is best to connect both clock inputs to the differential input clock signal with 0.1- μ F capacitors, as shown in Figure 40. A single-ended CMOS clock can be ac-coupled to the CLKP input, with CLKM connected to ground with a 0.1- μ F capacitor, as shown in Figure 41.

For high input frequency sampling, the use a clock source with very low jitter is recommended. Bandpass filtering of the clock source can help reduce the effect of jitter. There is no change in performance with a non-50% duty cycle clock input. Figure 23 shows the performance of the ADC versus clock duty cycle.

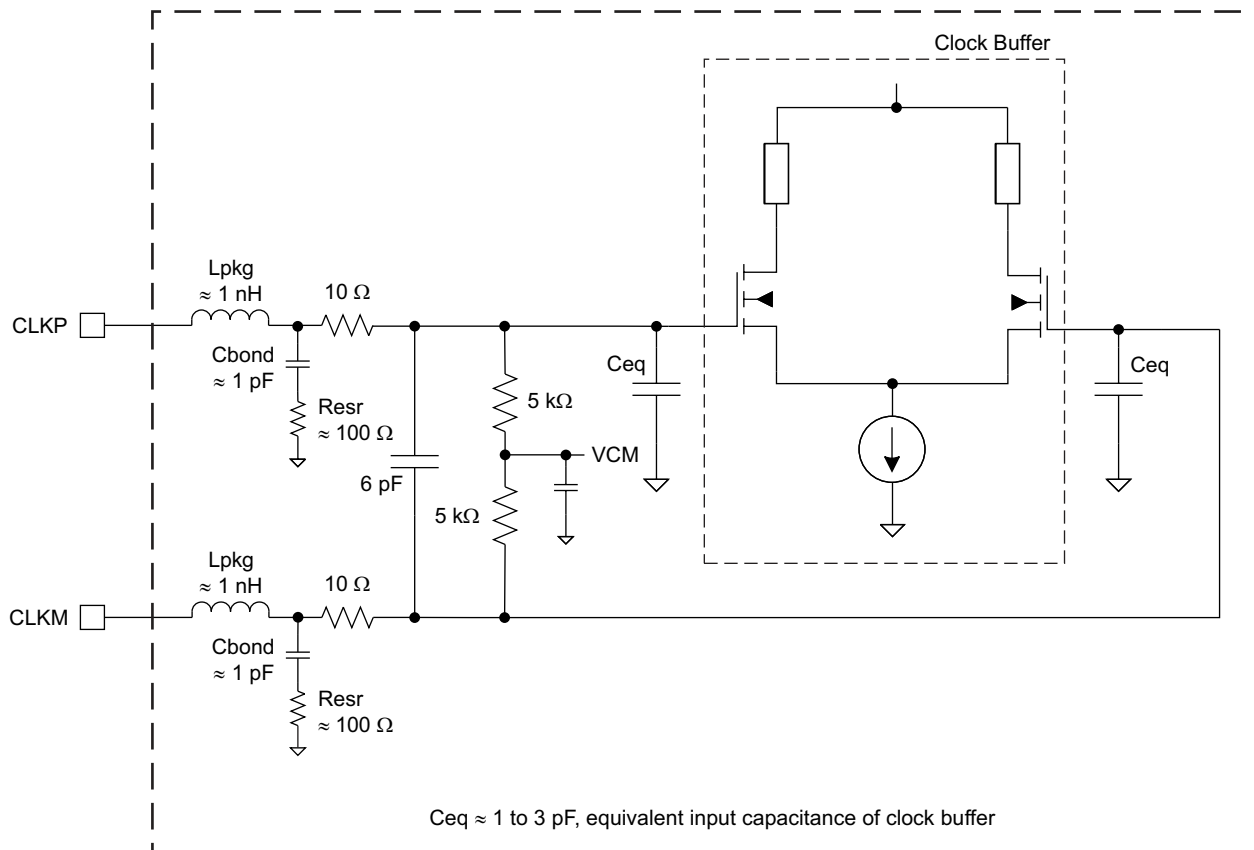

S0275-03

Figure 38. Internal Clock Buffer

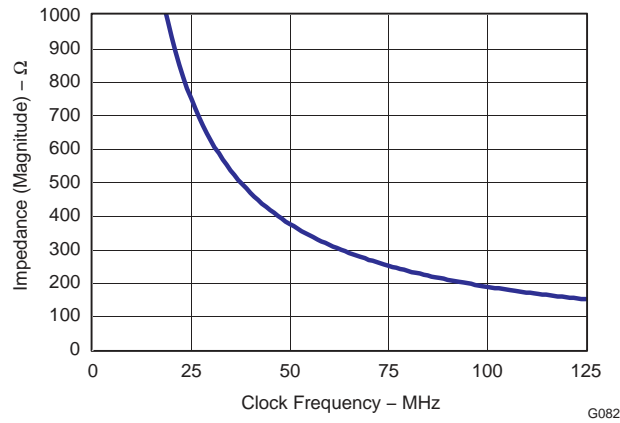

Figure 39. Clock Buffer Input Impedance

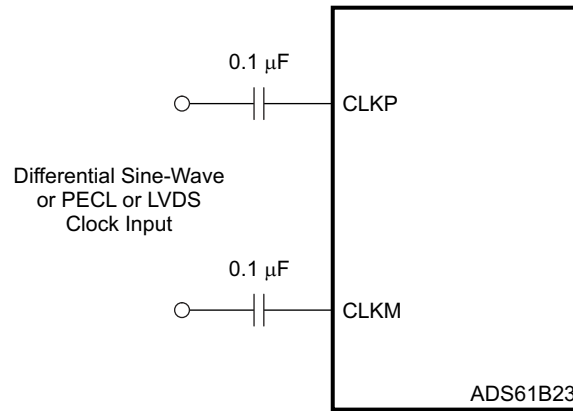

Figure 40. Differential Clock Driving Circuit

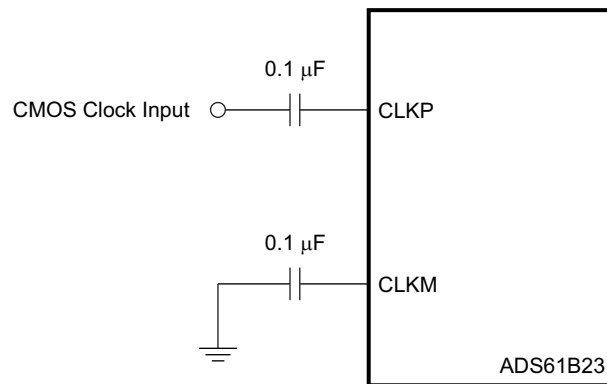

Figure 41. Single-Ended Clock Driving Circuit

POWER DOWN MODES

ADS61B23 has four power-down modes—global power down, standby, output buffer disable, and input clock stopped (normal operation). These modes can be set using the serial interface or the parallel interface (pins SDATA and PDN).

Table 17. Power Down Modes

POWER-DOWN MODES	PARALLEL INTERFACE		SERIAL INTERFACE REGISTER BIT (Table 6)	TOTAL POWER, mW (DRVDD=3.3V)	WAKE-UP TIME (to valid data)
	SDATA	PDN			
Normal operation	Low	Low	<PDN OBUF>=0 and <STBY>=0	372	-
Standby	Low	High	<PDN OBUF>=0 and <STBY>=1	168	Slow (50 μ s)
Output buffer disable	High	Low	<PDN OBUF>=1 and <STBY>=0	349	Fast (200 ns)
Global power down	High	High	<PDN OBUF>=1 and <STBY>=1	40	Slow (50 μ s)

Global Powerdown

In this mode, the A/D converter, internal references and the output buffers are powered down and the total power dissipation reduces to about 40 mW. The output buffers are in high impedance state. The wake-up time from the global power down to output data becoming valid in the normal mode is maximum 50 μ s. Note that after coming out of global power down, optimum performance will be achieved after the internal reference voltages have stabilized (about 1 ms).

Standby

Here, only the A/D converter is powered down and the total power dissipation is about 168 mW. The wake-up time from standby to output data becoming valid is maximum 50 μ s.

Output Buffer Disable

The data output buffers can be disabled, reducing the total power to about 350 mW. With the buffers disabled, the outputs are in high impedance state. The wake-up time from this mode to data becoming valid in normal mode is maximum 500 ns in LVDS mode and 200 ns in CMOS mode.

Input Clock Stop (Normal operation)

The converter enters this mode when the input clock frequency falls below 1 MSPS. The power dissipation is about 115 mW, and the wake-up time from this mode to data becoming valid in normal mode is maximum 50 μ s.

Power Supply Sequence

During power-up, the AVDD and DRVDD supplies can come up in any sequence. The two supplies are separated inside the device. Externally, they can be driven from separate supplies or from a single supply.

DIGITAL OUTPUT INTERFACE

ADS61B23 outputs 12 data bits together with an output clock. The output interface are either parallel CMOS or DDR LVDS voltage levels and can be selected using serial register bit **<LVDS CMOS>** or parallel pin SEN.

Parallel CMOS Interface

In the CMOS mode, the output buffer supply (DRVDD) can be operated over a wide range from 1.8 V to 3.3 V (typical). Each data bit is output on separate pin as CMOS voltage level, every clock cycle.

For DRVDD \geq 2.2 V, it is recommended to use the CMOS output clock (CLKOUT) to latch data in the receiving chip. The rising edge of CLKOUT can be used to latch data in the receiver, even at the highest sampling speed (125 MSPS). It is recommended to minimize the load capacitance seen by data and clock output pins by using short traces to the receiver. Also, match the output data and clock traces to minimize the skew between them.

For DRVDD < 2.2 V, it is recommended to use external clock (for example, input clock delayed to get desired setup/hold times).

Output Clock Position Programmability

There exists an option to shift (delay) the output clock position so that the setup time increases by 400 ps (typical, with respect to the default timings specified). This may be useful if the receiver needs more setup time, especially at high sampling frequencies. This can be programmed using the serial interface register bit **<CLKOUT_POSN>** (see [Table 7](#)).

Output Buffer Strength Programmability

Switching noise (caused by CMOS output data transitions) can couple into the analog inputs during the instant of sampling and degrade the SNR. The coupling and SNR degradation increases as the output buffer drive is made stronger. To minimize this, the ADS61B23 CMOS output buffers are designed with controlled drive strength to get best SNR. The default drive strength also ensures wide data stable window for load capacitances up to 5 pF and DRVDD supply voltage \geq 2.2 V.

To ensure wide data stable window for load capacitance > 5 pF, there is an option to increase the drive strength using the serial interface (**<DRIVE STRENGTH>**, see [Table 13](#)). Note that for DRVDD supply voltage < 2.2 V, it is recommended to use maximum drive strength (for any value of load capacitance).

CMOS Mode Power Dissipation

With CMOS outputs, the DRVDD current scales with the sampling frequency and the load capacitance on every output pin. The maximum DRVDD current occurs when each output bit toggles between 0 and 1 every clock cycle. In actual applications, this condition is unlikely to occur. The actual DRVDD current would be determined by the average number of output bits switching, which is a function of the sampling frequency and the nature of the analog input signal.

$$\text{Digital current due to CMOS output switching} = C_L \times \text{DRVDD} \times (N \times F_{\text{AVG}})$$

where C_L = load capacitance, $N \times F_{\text{AVG}}$ = average number of output bits switching

[Figure 33](#) shows the current with various load capacitances across sampling frequencies at 2 MHz analog input frequency.

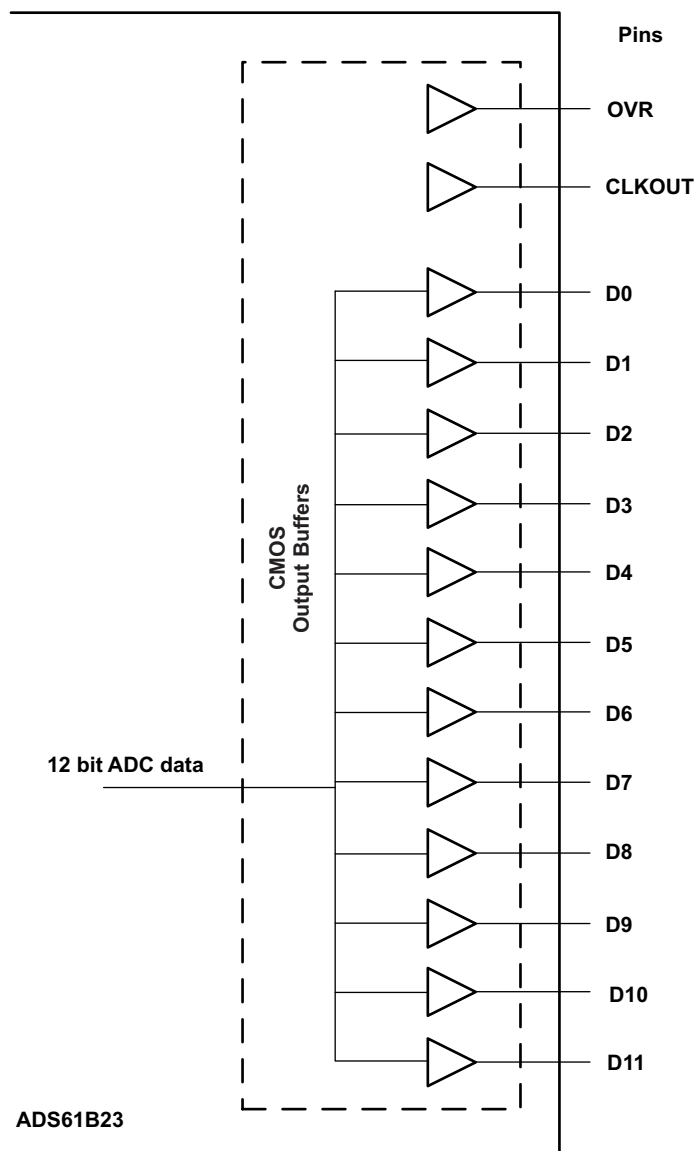

Figure 42. CMOS Output buffers

DDR LVDS Interface

The LVDS interface works only with 3.3 V DRVDD supply. In this mode, the 12 data bits and the output clock are available as LVDS (Low Voltage Differential Signal) levels. Two successive data bits are multiplexed and output on each LVDS differential pair every clock cycle (DDR - Double Data Rate, see Figure 43). So, there are 7 LVDS output pairs for the 12 data bits and 1 LVDS output pair for the output clock.

LVDS Buffer Current Programmability

The default LVDS buffer output current is 3.5 mA. When terminated by 100 Ω, this results in a 350-mV single-ended voltage swing (700-mV_{PP} differential swing). The LVDS buffer currents can also be programmed to 2.5 mA, 4.5 mA, and 1.75 mA (register bits <LVDS CURRENT>, see Table 12). In addition, there is a current double mode, where this current is doubled for the data and output clock buffers (register bits <CURRENT DOUBLE>, see Table 12).

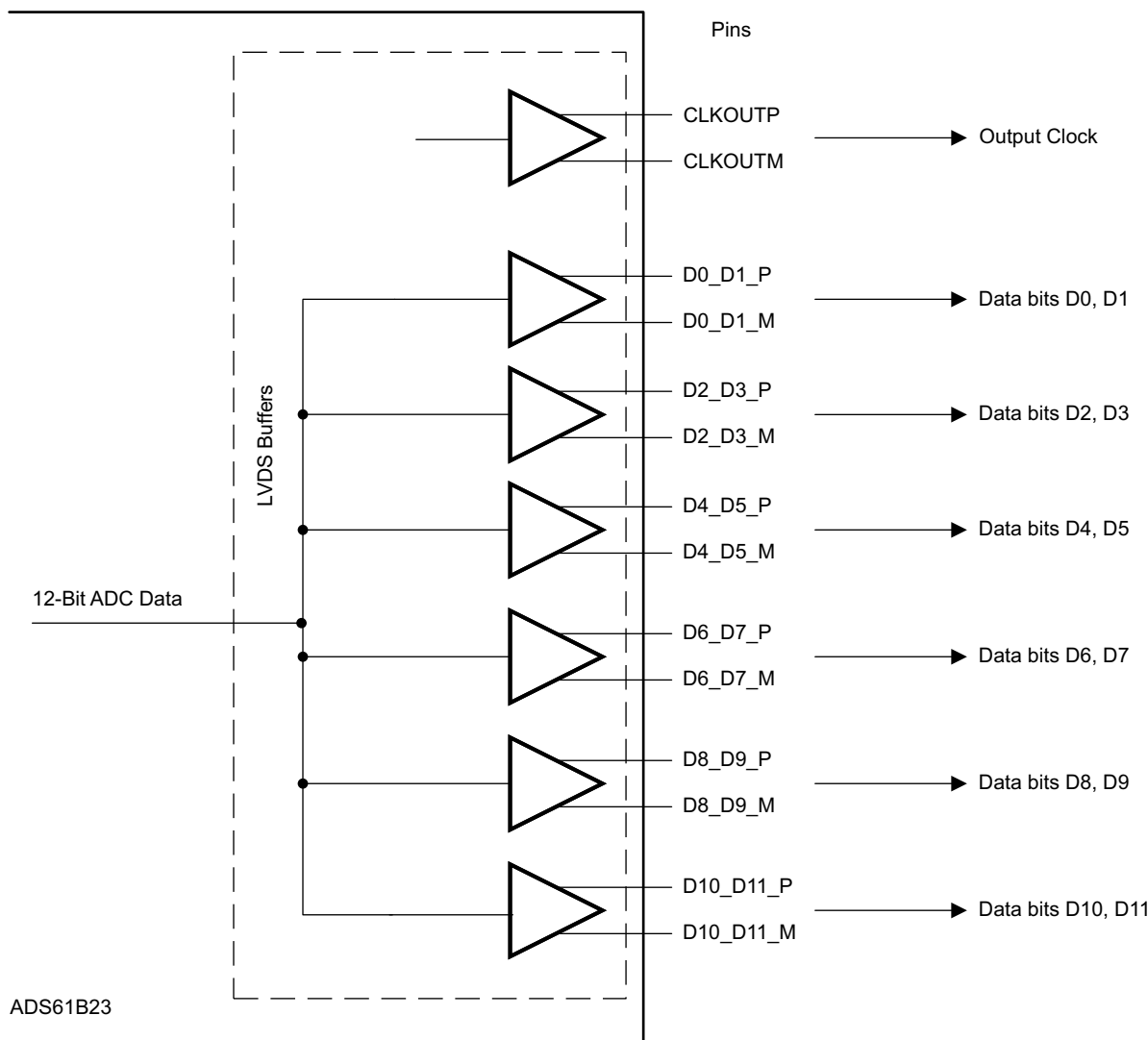

Figure 43. DDR LVDS Outputs

Even data bits D0, D2, D4, D6, D8, D10, and D12 are output at the rising edge of CLKOUTP and the odd data bits D1, D3, D5, D7, D9, D11, and D13 are output at the falling edge of CLKOUTP. Both the rising and falling edges of CLKOUTP must be used to capture all the 12 data bits (see Figure 44).

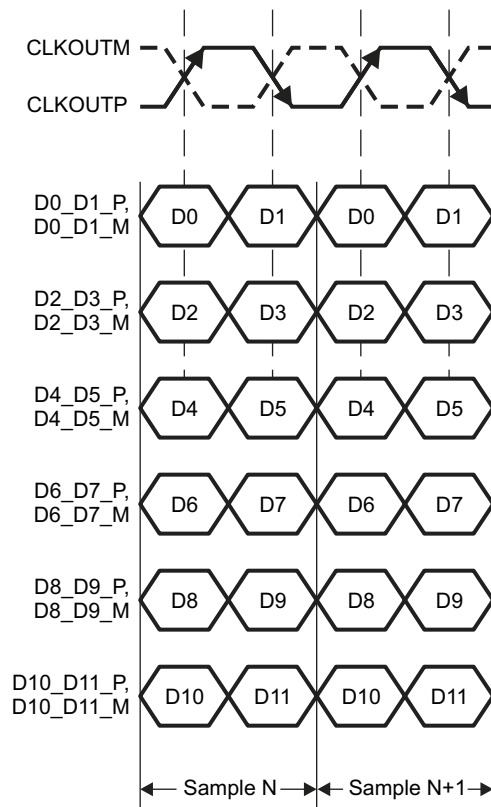

Figure 44. DDR LVDS Interface

LVDS Buffer Internal Termination

An internal termination option is available (using the serial interface), by which the LVDS buffers are differentially terminated inside the device. The termination resistors available are – 300 Ω , 185 Ω , and 150 Ω (nominal with $\pm 20\%$ variation). Any combination of these three terminations can be programmed; the effective termination is the parallel combination of the selected resistance. This results in eight effective terminations from open (no termination) to 65 Ω .

The internal termination helps to absorb any reflections coming from the receiver end, improving the signal integrity. With 100 Ω internal and 100 Ω external termination, the voltage swing at the receiver end is halved (compared to no internal termination). The voltage swing can be restored by using the LVDS current double mode. [Figure 45](#) and [Figure 46](#) compare the LVDS eye diagrams without and with internal termination (100 Ω). With internal termination, the eye looks clean even with 10 pF load capacitance (from each output pin to ground). The terminations is programmed using register bits <DATA TERM> and <CLKOUT TERM> (see [Table 12](#)).

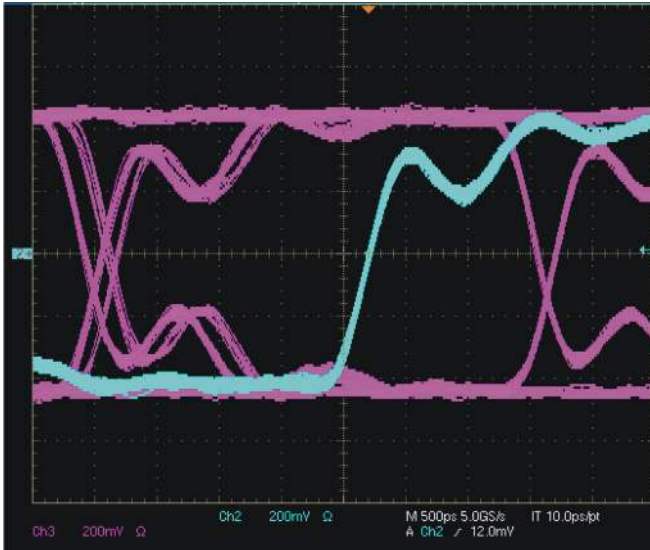

Figure 45. LVDS Eye Diagram - No Internal Termination
5-pF Load Capacitance
Blue Trace - Output Clock (CLKOUT)
Pink Trace - Output Data

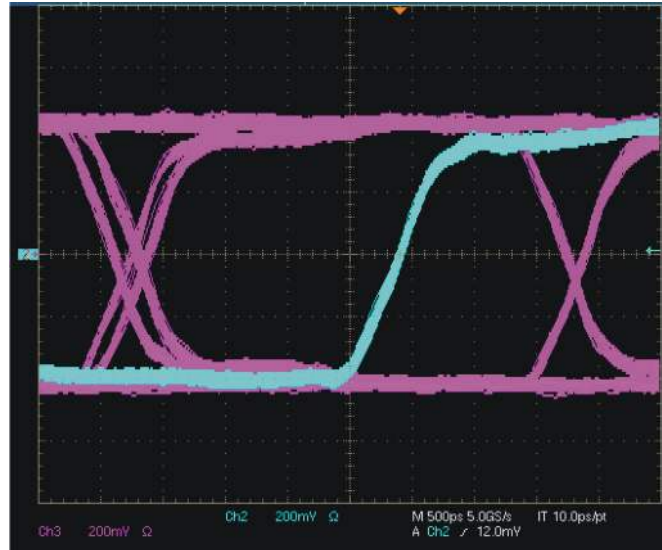

Figure 46. LVDS Eye Diagram with 100-Ω Internal Termination
10-pF Load Capacitance
Blue Trace - Output Clock (CLKOUT)
Pink Trace - Output Data

Output Data Format

Two output data formats are supported – 2s complement and offset binary. They can be selected using the parallel control pin SEN or the serial interface register bit **<DATA FORMAT>** (see [Table 9](#)).

BOARD DESIGN CONSIDERATIONS

Grounding

A single ground plane is sufficient to give good performance, provided the analog, digital and clock sections of the board are cleanly partitioned. See the *ADS61xx EVM User's Guide* ([SLAU206](#)) for details on layout and grounding.

Supply Decoupling

As the ADS61B23 already includes internal decoupling, minimal external decoupling can be used without loss in performance. Note that decoupling capacitors can help to filter external power supply noise, so the optimum number of capacitors would depend on the actual application. The decoupling capacitors should be placed very close to the converter supply pins.

It is recommended to use separate supplies for the analog and digital supply pins to isolate digital switching noise from sensitive analog circuitry. In case only a single 3.3-V supply is available, it should be routed first to AVDD. It can then be tapped and isolated with a ferrite bead (or inductor) with decoupling capacitor, before being routed to DRVDD.

Exposed Thermal Pad

It is necessary to solder the exposed pad at the bottom of the package to a ground plane for best thermal performance. For detailed information, see the *QFN Layout Guidelines* ([SLOA122](#)) and *QFN/SON PCB Attachment Application Report* ([SLUA271](#)) documents.

SPECIFICATION DEFINITIONS

Analog Bandwidth

Analog input frequency at which the power of the fundamental is reduced by 3 dB with respect to the low frequency value.

Aperture Delay

Time delay between the rising edge of the input sampling clock and the actual time at which the sampling occurs.

Aperture Uncertainty (Jitter)

Sample-to-sample variation in aperture delay.

Clock Pulse Width/Duty Cycle

Ratio of the time the clock signal remains at a logic high (clock pulse width) to the period of the clock signal. Duty cycle is typically expressed as a percentage. A perfect differential sine-wave clock results in a 50% duty cycle.

Maximum Conversion Rate

Maximum sampling rate at which certified operation is expressed. All parametric testing is performed at this sampling rate unless otherwise noted.

Minimum Conversion Rate

Minimum sampling rate at which the ADC functions.

Differential Nonlinearity (DNL)

An ideal ADC exhibits code transitions at analog input values spaced exactly 1 LSB apart. The DNL is the deviation of any single step from this ideal value, measured in units of LSBs.

Integral Nonlinearity (INL)

Deviation of the ADC's transfer function from a best fit line determined by a least squares curve fit of that transfer function, measured in units of least-significant bits (LSBs).

Gain Error

Deviation of the ADC's actual input full-scale range from its ideal value. The gain error is expressed as a percentage of the ideal input full-scale range.

Offset Error

Difference between the ADC's actual average idle channel output code and the ideal average idle channel output code. This quantity is often expressed in number of LSBs and converted to mV.

Temperature Drift

Coefficient (with respect to gain error and offset error) the specifies the change per degree Celsius of the parameter from T_{MIN} to T_{MAX} . It is calculated by dividing the maximum deviation of the parameter across the T_{MIN} to T_{MAX} range by the difference $T_{MAX}-T_{MIN}$.

Signal-to-Noise Ratio

Ratio of the power of the fundamental (P_S) to the noise floor power (P_N), excluding the power at dc and the first nine harmonics.

$$\text{SNR} = 10\text{Log}_{10} \frac{P_S}{P_N} \quad (3)$$

SNR is expressed in units of dBc (dB to carrier) when the absolute power of the fundamental is used as the reference, or in dBFS (dB to full scale) when the power of the fundamental is extrapolated to the converter's full-scale range.

Signal-to-Noise and Distortion (SINAD)

Ratio of the power of the fundamental (P_S) to the power of all the other spectral components including noise (P_N) and distortion (P_D), but excluding dc.

$$\text{SINAD} = 10\text{Log}_{10} \frac{P_S}{P_N + P_D} \quad (4)$$

SINAD is expressed in units of dBc (dB to carrier) when the absolute power of the fundamental is used as the reference, or in dBFS (dB to full scale) when the power of the fundamental is extrapolated to the converter's full-scale range.

Effective Number of Bits (ENOB)

A measure of a converter's performance as compared to the theoretical limit based on quantization noise.

$$\text{ENOB} = \frac{\text{SINAD} - 1.76}{6.02} \quad (5)$$

Total Harmonic Distortion (THD)

Ratio of the power of the fundamental (P_S) to the power of the first nine harmonics (P_D).

$$\text{THD} = 10\text{Log}_{10} \frac{P_S}{P_N} \quad (6)$$

THD is typically expressed in units of dBc (dB to carrier).

Spurious-Free Dynamic Range (SFDR)

Ratio of the power of the fundamental to the highest other spectral component (either spur or harmonic). SFDR is typically expressed in units of dBc (dB to carrier).

Two-Tone Intermodulation Distortion (IMD3)

Ratio of the power of the fundamental (at frequencies f_1 and f_2) to the power of the worst spectral component at either frequency $2f_1-f_2$ or $2f_2-f_1$. IMD3 is expressed in units of dBc (dB to carrier) when the absolute power of the fundamental is used as the reference, or in dBFS (dB to full scale) when the power of the fundamental is extrapolated to the converter's full-scale range.

DC Power Supply Rejection Ratio (DC PSRR)

Ratio of the change in offset error to a change in analog supply voltage. The DC PSRR is typically expressed in units of mV/V.

AC Power Supply Rejection Ratio (AC PSRR)

Measure of rejection of variations in the supply voltage of the ADC. If ΔV_{SUP} is the change in the supply voltage and ΔV_{OUT} is the resultant change in the ADC output code (referred to the input), then

$$\text{PSRR} = 20\text{Log}^{10} \frac{\Delta V_{\text{OUT}}}{\Delta V_{\text{SUP}}} \quad (\text{Expressed in dBc}) \quad (7)$$

Common Mode Rejection Ratio (CMRR)

Measure of rejection of variations in the input common-mode voltage of the ADC. If ΔV_{cm} is the change in the input common-mode voltage and ΔV_{OUT} is the resultant change in the ADC output code (referred to the input), then

$$\text{CMRR} = 20\text{Log}^{10} \frac{\Delta V_{\text{OUT}}}{\Delta V_{\text{CM}}} \quad (\text{Expressed in dBc}) \quad (8)$$

Voltage Overload Recovery

Number of clock cycles taken to recover to less than 1% error for a 6-dB overload on the analog inputs. A 6-dBFS sine wave at Nyquist frequency is used as the test stimulus.

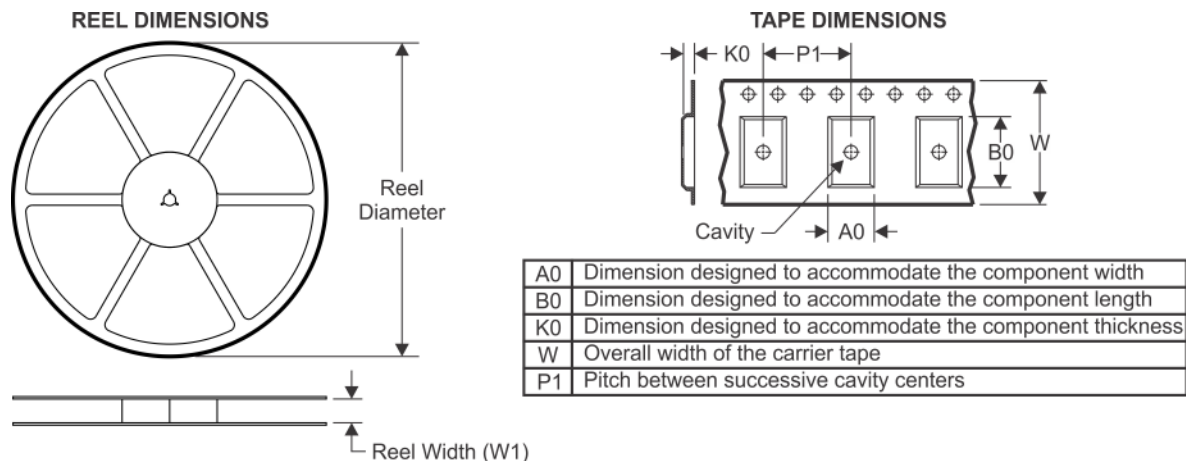
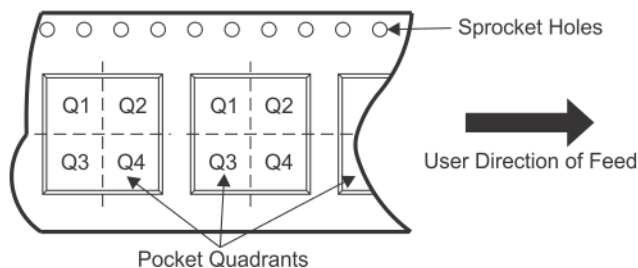
TAPE AND REEL INFORMATION

QUADRANT ASSIGNMENTS FOR PIN 1 ORIENTATION IN TAPE

*All dimensions are nominal

Device	Package Type	Package Drawing	Pins	SPQ	Reel Diameter (mm)	Reel Width W1 (mm)	A0 (mm)	B0 (mm)	K0 (mm)	P1 (mm)	W (mm)	Pin1 Quadrant
ADS61B23IRHBR	VQFN	RHB	32	3000	330.0	12.4	5.3	5.3	1.5	8.0	12.0	Q2

TAPE AND REEL BOX DIMENSIONS

*All dimensions are nominal

Device	Package Type	Package Drawing	Pins	SPQ	Length (mm)	Width (mm)	Height (mm)
ADS61B23IRHBR	VQFN	RHB	32	3000	350.0	350.0	43.0

GENERIC PACKAGE VIEW

RHB 32

VQFN - 1 mm max height

5 x 5, 0.5 mm pitch

PLASTIC QUAD FLATPACK - NO LEAD

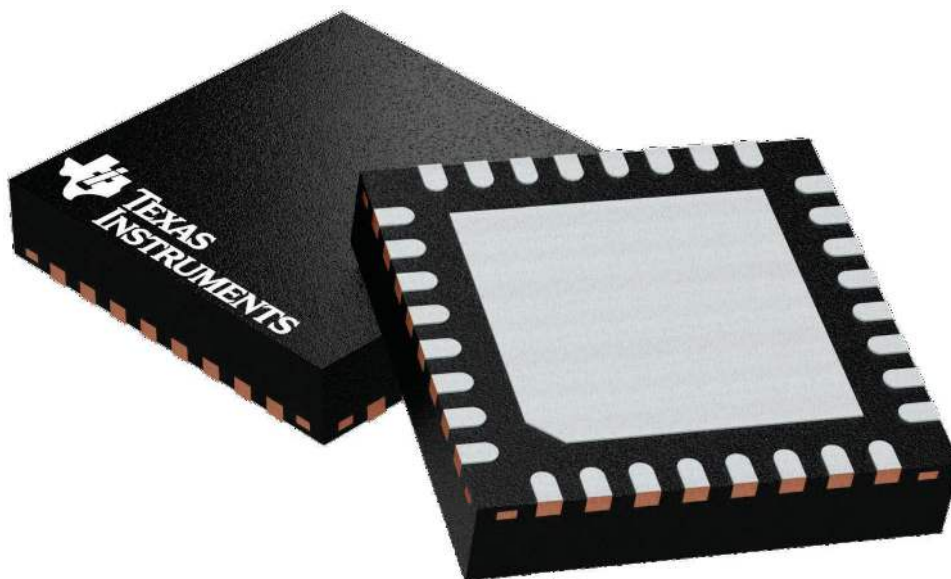

Images above are just a representation of the package family, actual package may vary.
Refer to the product data sheet for package details.

4224745/A

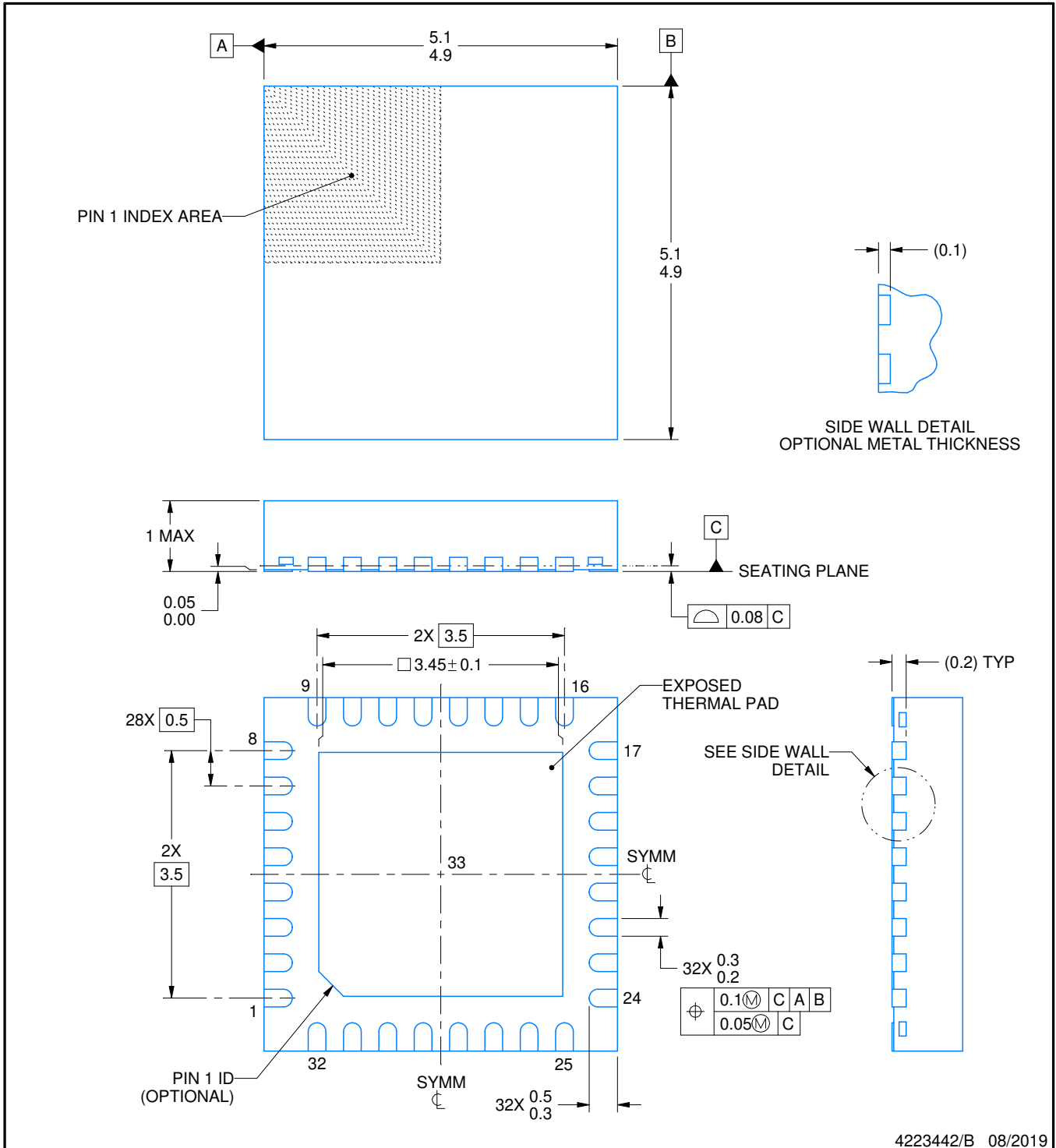
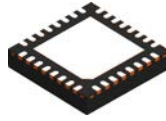

4223442/B 08/2019

NOTES:

1. All linear dimensions are in millimeters. Any dimensions in parenthesis are for reference only. Dimensioning and tolerancing per ASME Y14.5M.
2. This drawing is subject to change without notice.
3. The package thermal pad must be soldered to the printed circuit board for thermal and mechanical performance.

EXAMPLE BOARD LAYOUT

RHB0032E

VQFN - 1 mm max height

PLASTIC QUAD FLATPACK - NO LEAD

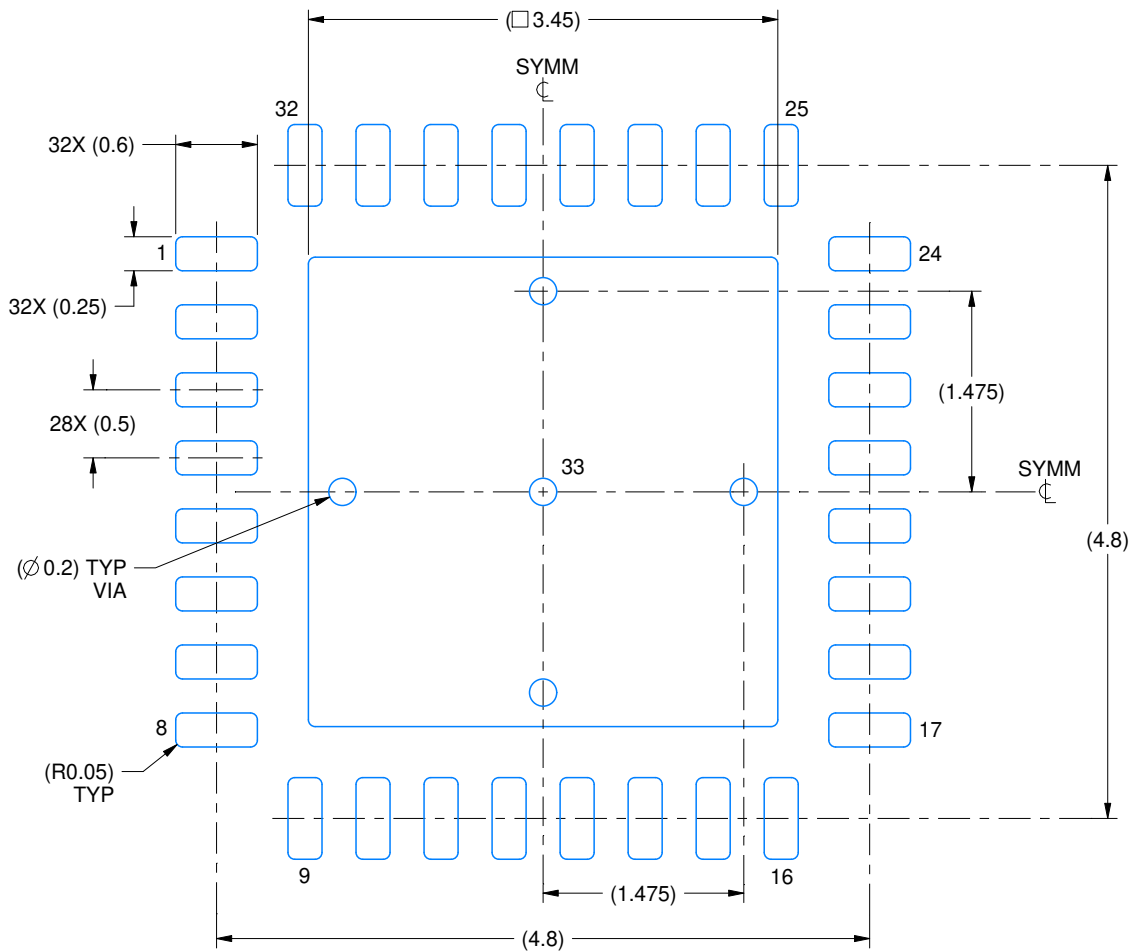

LAND PATTERN EXAMPLE
SCALE:18X

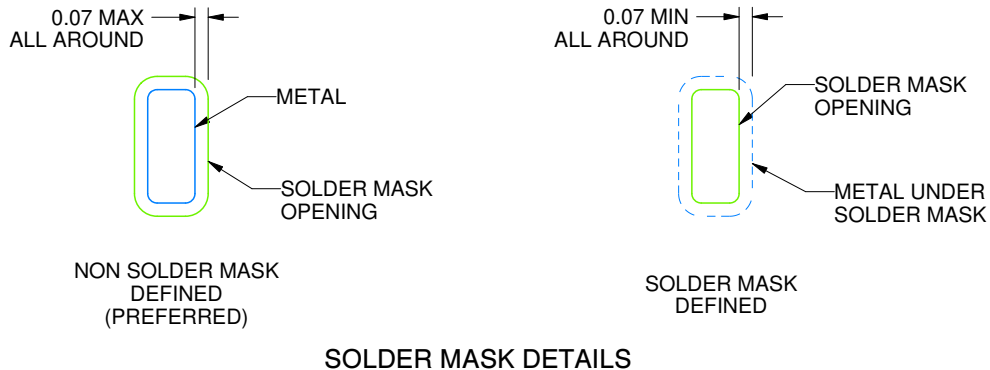

SOLDER MASK DETAILS

4223442/B 08/2019

NOTES: (continued)

- This package is designed to be soldered to a thermal pad on the board. For more information, see Texas Instruments literature number SLUA271 (www.ti.com/lit/slua271).
- Vias are optional depending on application, refer to device data sheet. If any vias are implemented, refer to their locations shown on this view. It is recommended that vias under paste be filled, plugged or tented.

EXAMPLE STENCIL DESIGN

RHB0032E

VQFN - 1 mm max height

PLASTIC QUAD FLATPACK - NO LEAD

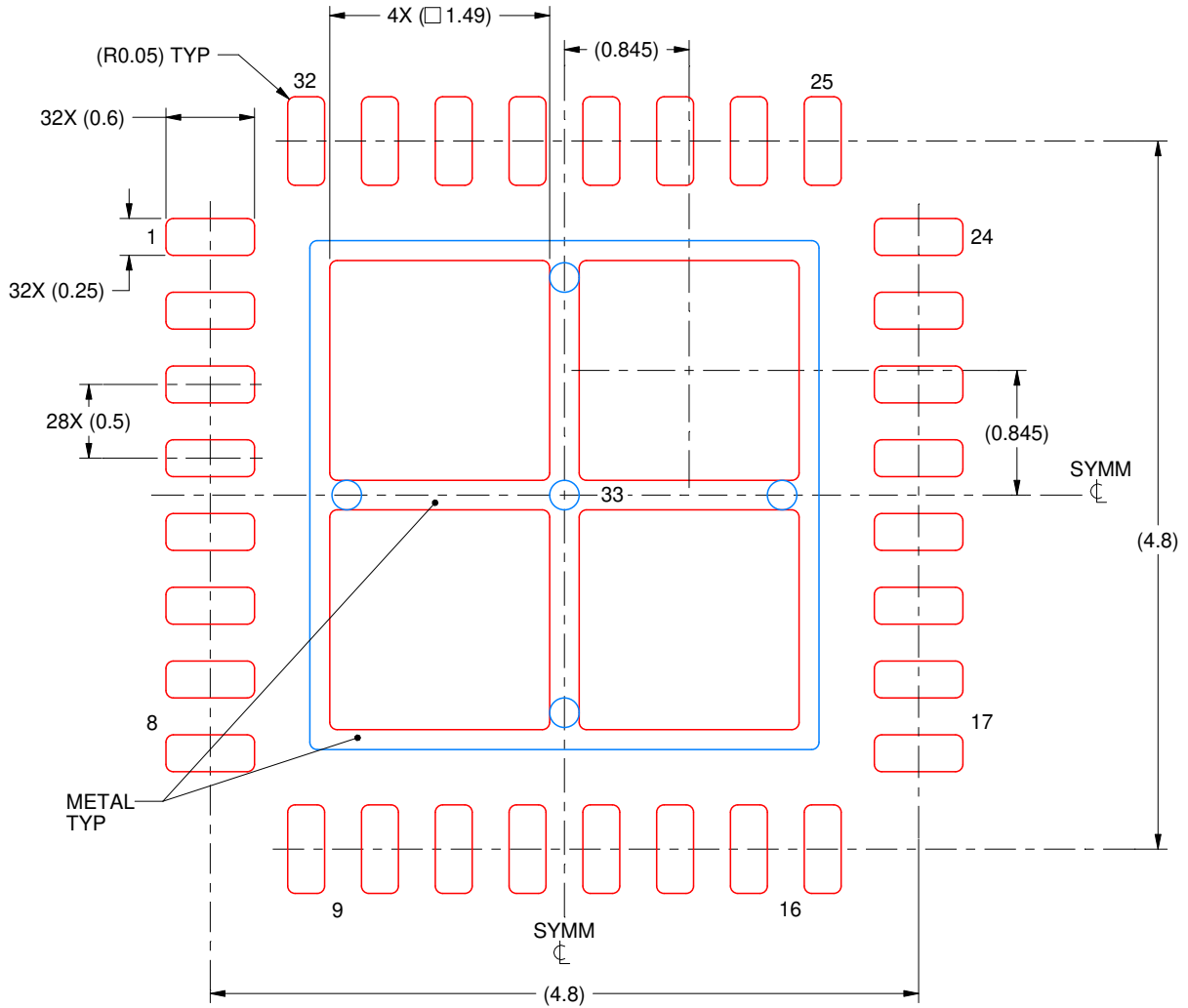

SOLDER PASTE EXAMPLE
 BASED ON 0.125 mm THICK STENCIL

EXPOSED PAD 33:
 75% PRINTED SOLDER COVERAGE BY AREA UNDER PACKAGE
 SCALE:20X

4223442/B 08/2019

NOTES: (continued)

6. Laser cutting apertures with trapezoidal walls and rounded corners may offer better paste release. IPC-7525 may have alternate design recommendations.

IMPORTANT NOTICE AND DISCLAIMER

TI PROVIDES TECHNICAL AND RELIABILITY DATA (INCLUDING DATASHEETS), DESIGN RESOURCES (INCLUDING REFERENCE DESIGNS), APPLICATION OR OTHER DESIGN ADVICE, WEB TOOLS, SAFETY INFORMATION, AND OTHER RESOURCES "AS IS" AND WITH ALL FAULTS, AND DISCLAIMS ALL WARRANTIES, EXPRESS AND IMPLIED, INCLUDING WITHOUT LIMITATION ANY IMPLIED WARRANTIES OF MERCHANTABILITY, FITNESS FOR A PARTICULAR PURPOSE OR NON-INFRINGEMENT OF THIRD PARTY INTELLECTUAL PROPERTY RIGHTS.

These resources are intended for skilled developers designing with TI products. You are solely responsible for (1) selecting the appropriate TI products for your application, (2) designing, validating and testing your application, and (3) ensuring your application meets applicable standards, and any other safety, security, or other requirements. These resources are subject to change without notice. TI grants you permission to use these resources only for development of an application that uses the TI products described in the resource. Other reproduction and display of these resources is prohibited. No license is granted to any other TI intellectual property right or to any third party intellectual property right. TI disclaims responsibility for, and you will fully indemnify TI and its representatives against, any claims, damages, costs, losses, and liabilities arising out of your use of these resources.

TI's products are provided subject to TI's Terms of Sale (<https://www.ti.com/legal/termsofsale.html>) or other applicable terms available either on [ti.com](https://www.ti.com) or provided in conjunction with such TI products. TI's provision of these resources does not expand or otherwise alter TI's applicable warranties or warranty disclaimers for TI products.

Mailing Address: Texas Instruments, Post Office Box 655303, Dallas, Texas 75265
Copyright © 2021, Texas Instruments Incorporated