| | |
|-----------------|--|
| Title | <i>Reference Design Report for a 1.44 W Non-Isolated Buck Converter Using LinkSwitchTM-TN2 LNK3204D/ P/ G</i> |
| Specification | Input: 85 VAC – 265 VAC; Output: 12 V, 120 mA |
| Application | Small Appliance |
| Author | Applications Engineering Department |
| Document Number | RDR-506 |
| Date | November 8, 2016 |
| Revision | 1.0 |

Summary and Features

- Highly integrated solution
- Lowest possible component count
- No optocoupler or Zener diode required for regulation
- Thermal overload protection with automatic recovery
- <30 mW no-load consumption
- >75% efficiency at full load
- <±3% load regulation

PATENT INFORMATION

The products and applications illustrated herein (including transformer construction and circuits external to the products) may be covered by one or more U.S. and foreign patents, or potentially by pending U.S. and foreign patent applications assigned to Power Integrations. A complete list of Power Integrations' patents may be found at www.powerint.com. Power Integrations grants its customers a license under certain patent rights as set forth at <<http://www.powerint.com/ip.htm>>.

Table of Contents

| | | |
|--------|--|----|
| 1 | Introduction | 3 |
| 2 | Power Supply Specification | 4 |
| 3 | Schematic..... | 5 |
| 4 | Circuit Description | 6 |
| 4.1 | Input EMI Filtering..... | 6 |
| 4.2 | LinkSwitch-TN2 IC Primary..... | 6 |
| 4.3 | Output Rectification | 7 |
| 4.4 | Output Feedback | 7 |
| 5 | PCB Layout | 8 |
| 6 | Bill of Materials | 9 |
| 7 | Transformer Design Spreadsheet | 10 |
| 8 | Performance Data | 11 |
| 8.1 | Efficiency vs. Line | 11 |
| 8.2 | Efficiency vs. Load | 12 |
| 8.3 | No-Load Input Power | 13 |
| 8.4 | Load Regulation | 14 |
| 8.5 | Line Regulation at Full Load | 15 |
| 9 | Open Case Thermal Performance | 16 |
| 10 | Waveforms..... | 17 |
| 10.1 | Switching Waveforms..... | 17 |
| 10.1.1 | LNK3204D Waveforms..... | 17 |
| 10.1.2 | LNK3204D Drain Voltage and Current Waveforms During Start-up | 17 |
| 10.1.3 | Drain Current and Output Waveform During Output Short | 18 |
| 10.1.4 | Freewheeling Diode Waveforms..... | 18 |
| 10.1.5 | Output Voltage and Current Waveforms During Start-Up..... | 19 |
| 10.2 | Output Ripple Measurements..... | 20 |
| 11.2.1 | Ripple Measurement Technique | 20 |
| 10.2.2 | Measurement Results..... | 21 |
| 10.2.3 | Ripple Voltage Waveforms..... | 22 |
| 11 | Conductive EMI | 23 |
| 11.1 | 120 mA Resistive Load, Floating Output (QPK / AV) | 23 |
| 11.1.1 | Line | 23 |
| 11.1.2 | Neutral..... | 25 |
| 12 | Lighting Surge | 27 |
| 12.1 | Differential Mode Test..... | 27 |
| 13 | Revision History | 28 |

Important Note:

Although this board is designed to satisfy safety isolation requirements, the engineering prototype has not been agency approved. Therefore, all testing should be performed using an isolation transformer to provide the AC input to the prototype board.



1 Introduction

This document is an engineering prototype report describing a non-isolated 12 V, 120 mA power supply utilizing a LNK3204D/P/G from Power Integrations.

The document contains the power supply specification, schematic, bill-of-materials, printed circuit layout, and performance data.

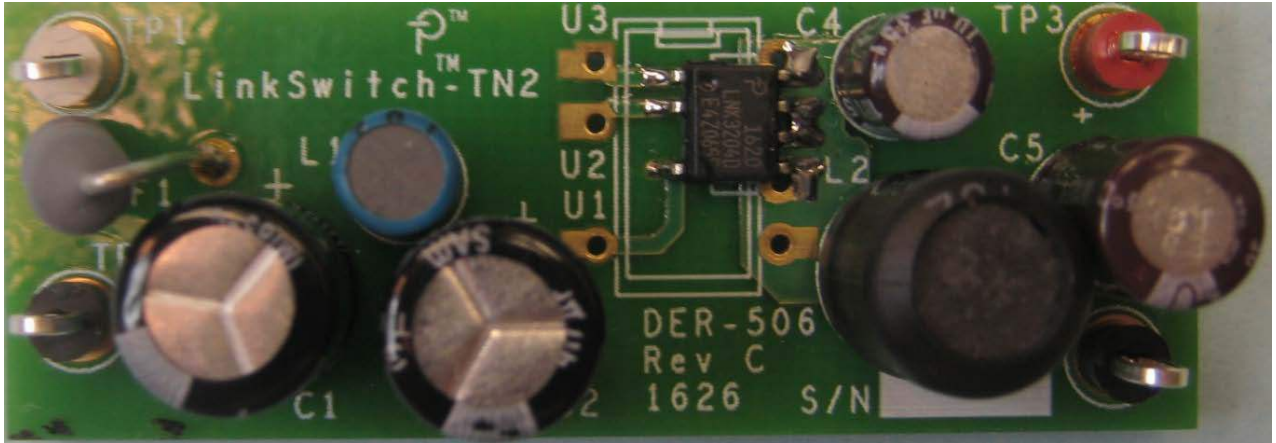

Figure 1– Populated Circuit Board Photograph, Top.

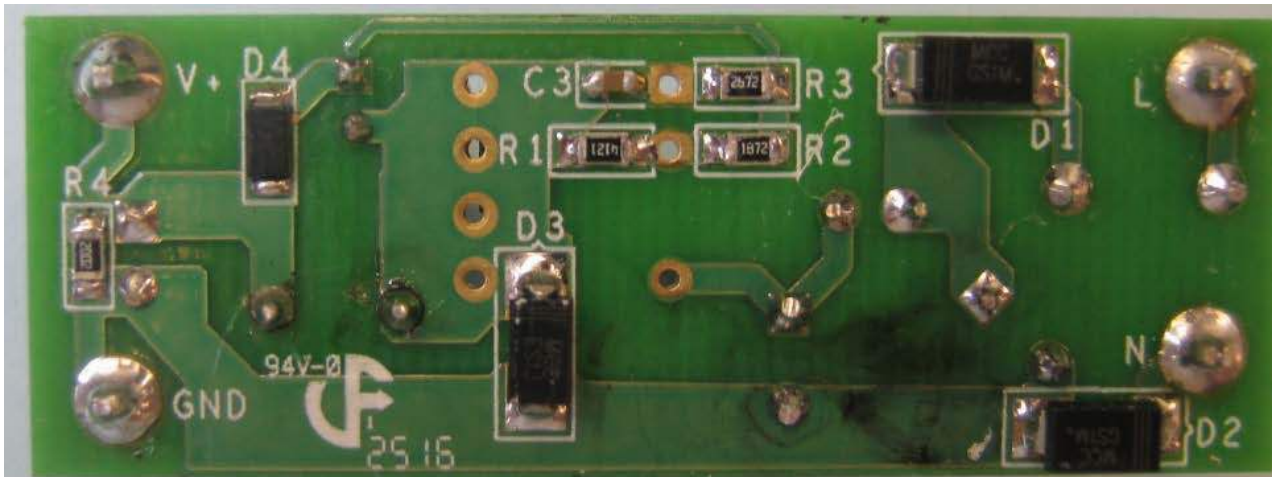

Figure 2 – Populated Circuit Board Photograph, Bottom.

2 Power Supply Specification

The table below represents the minimum acceptable performance of the design. Actual performance is listed in the results section.

| Description | Symbol | Min | Typ | Max | Units | Comment |
|---|-----------------|---------------------------|-------|-----|-------|---|
| Input Voltage | V_{IN} | 85 | | 265 | VAC | 2 Wire – no P.E. |
| Frequency | f_{LINE} | 47 | 50/60 | 64 | Hz | |
| No-load Input Power (230 VAC) | | | | <30 | mW | |
| Output Output Voltage | V_{OUT} | | 12 | | V | ± 5%. 20 MHz Bandwidth. |
| Output Ripple Voltage | V_{RIPPLE} | | | 150 | mV | |
| Output Current | I_{OUT} | | 0.12 | | A | |
| Total Output Power | | | | | | |
| Continuous Output Power | P_{OUT} | | 1.44 | | W | |
| Peak Output Power | P_{OUT_PEAK} | | | | W | |
| Efficiency Full Load | η | 75 | | | % | Measured at P_{OUT} 25 °C. |
| Environmental Conducted EMI | | Meets CISPR22B / EN55022B | | | | |
| Line Surge Differential Mode (L1-L2) | | | 1 | | kV | 1.2/50 μ s surge, IEC 1000-4-5, Series Impedance: Differential Mode: 2 Ω . |
| Ambient Temperature | T_{AMB} | 0 | | 40 | °C | Free Convection, Sea Level. |

3 Schematic

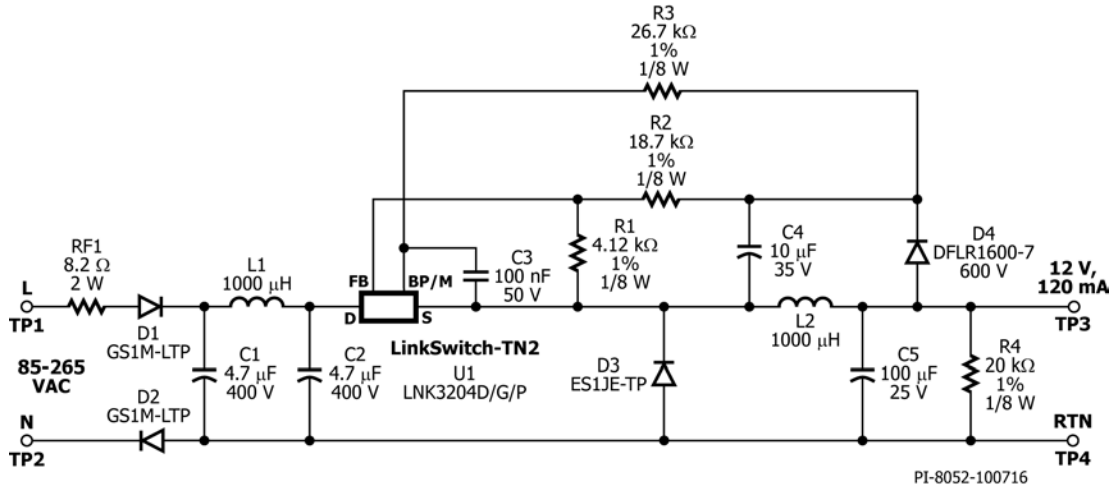

Figure 3 – Schematic.

* Note: U1 can be implemented as LNK3204D, LNK3204G or LNK3204P.



4 Circuit Description

The schematic in Figure 3 shows a buck converter using LNK3204D/P/G. The circuit provides a non-isolated 12 V, 120 mA continuous output. In metering applications this is used to supply the control circuits and micro controller. LinkSwitch-TN2 integrates a 725 V MOSFET and control circuitry into a single low cost IC. Regulation is achieved using a low cost resistor divider feedback network. The switching frequency jitter feature of the LinkSwitch-TN2 family and the 66 kHz switching frequency of operation helps reduce EMI.

4.1 *Input EMI Filtering*

The input stage is comprised of fusible resistor RF1, diode D1 and D2, capacitors C1 and C2, and inductor L1. Resistor RF1 is a flameproof, fusible, wire-wound resistor. It accomplishes several functions: (a) limits inrush current to safe levels for rectifiers D1, D2 (b) provides differential mode noise attenuation and (c) acts as an input fuse in the event any other component fails short circuit. As this component is used as a fuse, it should fail safely open-circuit without emitting smoke, fire or incandescent material to meet typical safety requirements. To withstand the instantaneous inrush power dissipation, wire wound types are recommended. Metal film resistors are not recommended in place of RF1.

4.2 *LinkSwitch-TN2 IC Primary*

LinkSwitch-TN2 integrates a 725 V power MOSFET and control circuitry into a single low cost IC. The device is self-starting from the DRAIN (D) pin with local supply decoupling provided by a small 100 nF capacitor C3 connected to the BYPASS (BP/M) pin when AC is first applied. During normal operation the device is powered from output via a current limiting resistor R3. Here, the device LNK3204D is used in a buck converter. The supply is designed to operate in mostly discontinuous conduction mode (MDCM), with the peak L1 inductor current set by the LNK3204D internal current limit. The control scheme used is similar to the ON/OFF control used in TinySwitch™. The on-time for each switching cycle is set by the inductance value of L2, LinkSwitch-TN2 current limit and the high voltage DC input bus across C2. Output regulation is accomplished by skipping switching cycles in response to an ON/OFF feedback signal applied to the FEEDBACK (FB) pin. This differs significantly from traditional PWM schemes that control the duty factor (duty cycle) of each switching cycle. Unlike TinySwitch, the logic of the FB pin has been inverted in LinkSwitch-TN. This allows a very simple feedback scheme to be used when the device is used in the buck converter configuration. Current into the FB pin greater than 49 μ A will inhibit the switching of the internal MOSFET, while current below this allows switching cycles to occur.

4.3 *Output Rectification*

During the ON time of U1, current ramps in L2 and is simultaneously delivered to the load. During the OFF time the inductor current ramps down via free-wheeling diode D3 into C5 and is delivered to the load. Diode D3 should be selected as an ultrafast diode (t_{RR} of 35 ns or better is recommended. Capacitor C5 should be selected to have an adequate ripple current rating (low ESR type)). Please see the spreadsheet output capacitor section.

4.4 *Output Feedback*

The voltage across L2 is rectified and smoothed by D4 and C4 during the off-time of U1. To a first order, the forward voltage drops of D3 and D4 are identical and therefore, the voltage across C3 tracks the output voltage. To provide a feedback signal, the voltage developed across C3 is divided by R1 and R2 and connected to U1's FB pin. The values of R1 and R2 are selected such that at the nominal output voltage, the voltage on the FB pin is 2 V. This voltage is specified for U1 at an FB pin current of 49 μ A with a tolerance of $\pm 1.3\%$ over a temperature range of -40 to 125 $^{\circ}$ C. This allows this simple feedback to meet the required overall output tolerance of $\pm 3\%$ at rated output current.

5 PCB Layout

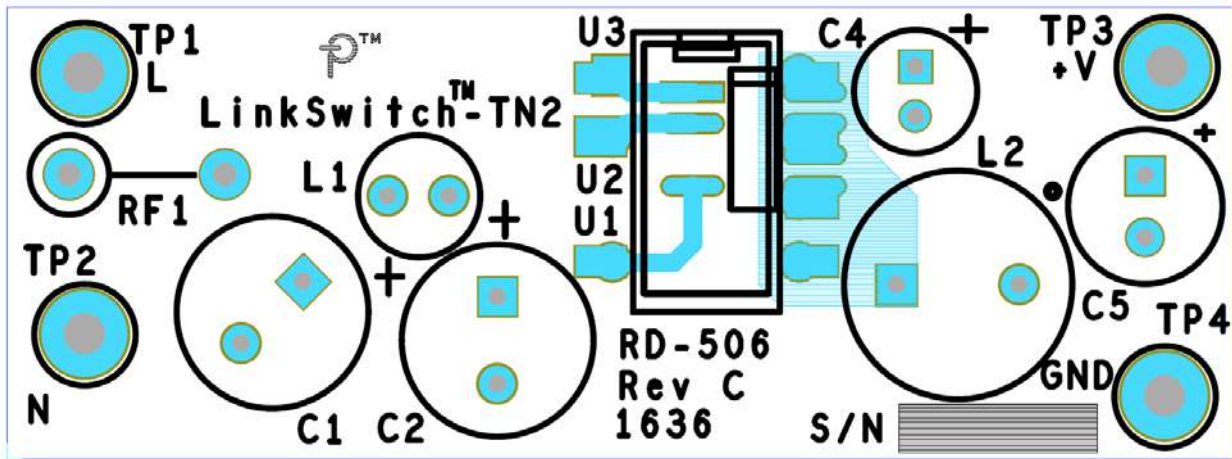

Figure 4 – Printed Circuit Layout, Top (1.97" [50 mm] L x .72" [18.4 mm] W).

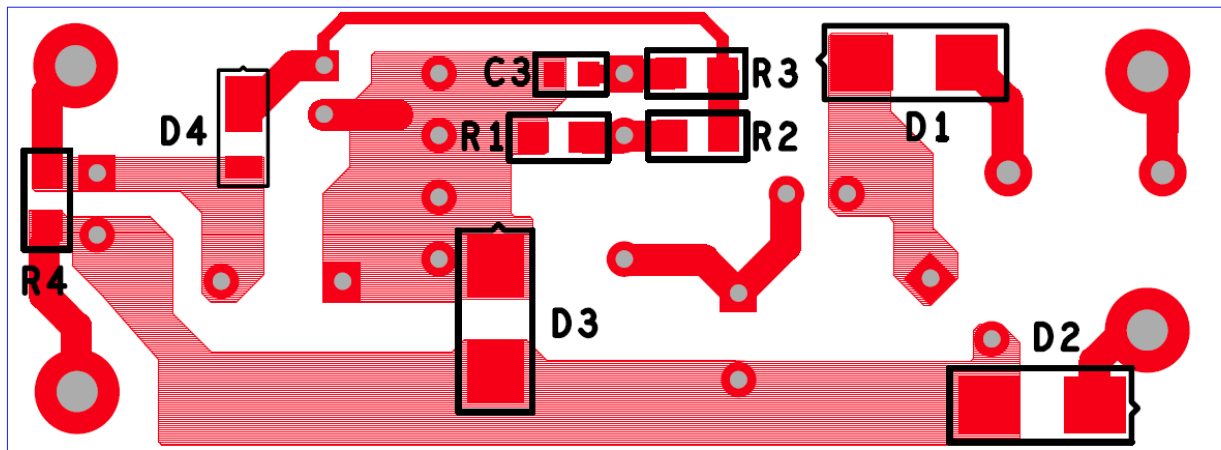

Figure 5 – Printed Circuit Layout, Bottom.

6 Bill of Materials

| Item | Qty | Ref Des | Description | Mfg Part Number | Mfg |
|------|-----|---------|--|--------------------|--------------------|
| 1 | 2 | C1 C2 | 4.7 μ F, 400 V, Electrolytic, (8 x 11.5) | SHD400WV 4.7uF | Sam Young |
| 2 | 1 | C3 | 100 nF 50 V, Ceramic, X7R, 0603 | C1608X7R1H104K | TDK |
| 3 | 1 | C4 | 10 μ F, 35 V, Electrolytic, Gen Purpose, (5 x 7) | UPW1V100MDD6 | Nichicon |
| 4 | 1 | C5 | 100 μ F, 25 V, Electrolytic, Very Low ESR, 130 m Ω , (6.3 x 11) | EKZE250ELL101MF11D | Nippon Chemi-Con |
| 5 | 2 | D1 D2 | 1000 V, 1 A, DO-214AC | GS1M-LTP | Micro Commercial |
| 6 | 1 | D3 | DIODE, GEN PURP, 600V, 1A, DO214AC | ES1JE-TP | Micro Commercial |
| 7 | 1 | D4 | 600 V, 1 A, Rectifier, Glass Passivated, POWERDI 123 | DFLR1600-7 | Diodes, Inc. |
| 8 | 1 | L1 | 1000 μ H, 0.21 A, 5.5 x 10.5 mm | SBC1-102-211 | Tokin |
| 9 | 1 | L2 | 1000 μ H, 0.510 A | RLB9012-102KL | Bourns |
| 10 | 1 | R1 | RES, 4.12 k Ω , 1%, 1/8 W, Thick Film, 0805 | ERJ-6ENF4121V | Panasonic |
| 11 | 1 | R2 | RES, 18.7 k Ω , 1%, 1/8 W, Thick Film, 0805 | ERJ-6ENF1872V | Panasonic |
| 12 | 1 | R3 | RES, 26.7 k Ω , 1%, 1/8 W, Thick Film, 0805 | ERJ-6ENF2672V | Panasonic |
| 13 | 1 | R4 | RES, 20 k Ω , 1%, 1/8 W, Thick Film, 0805 | ERJ-6ENF2002V | Panasonic |
| 14 | 1 | RF1 | RES, 8.2 Ω , 2 W, Fusible/Flame Proof Wire Wound | CRF253-4 5T 8R2 | Vitrohm |
| 15 | 1 | TP1 | Test Point, WHT, THRU-HOLE MOUNT | 5012 | Keystone |
| 16 | 2 | TP2 TP4 | Test Point, BLK, THRU-HOLE MOUNT | 5011 | Keystone |
| 17 | 1 | TP3 | Test Point, RED, THRU-HOLE MOUNT | 5010 | Keystone |
| 18 | 1 | U1 | LinkSwitch-TN2, LNK3204D, SO-8C | LNK3204D | Power Integrations |
| 19 | 1 | U2 | LinkSwitch-TN2, LNK3204G, SMD-8C | LNK3204G | Power Integrations |
| 20 | 1 | U3 | LinkSwitch-TN2, LNK3204P, DIP-8C | LNK3204P | Power Integrations |

7 Transformer Design Spreadsheet

| ACDC_LinkSwitch-TN_042413; Rev.2.6; Copyright Power Integrations 2007 | INPUT | INFO | OUTPUT | UNIT | LinkSwitch-TN_Rev_2-6.xls: LinkSwitch-TN Design Spreadsheet |
|---|-------|------|---------|--------|---|
| INPUT VARIABLES | | | | | |
| VACMIN | 85 | | | Volts | Minimum AC Input Voltage |
| VACMAX | 265 | | | Volts | Maximum AC Input Voltage |
| FL | 50 | | | Hertz | Line Frequency |
| VO | 12.00 | | | Volts | Output Voltage |
| IO | 0.120 | | | Amps | Output Current |
| EFFICIENCY (User Estimate) | 0.75 | | | | Overall Efficiency Estimate (Adjust to match Calculated, or enter Measured Efficiency) |
| EFFICIENCY (Calculated Estimate) | | | 0.76 | | Calculated % Efficiency Estimate |
| CIN | 9.40 | | 9.40 | uF | Input Filter Capacitor |
| Input Stage Resistance | | | 0.00 | ohms | Input Stage Resistance, Fuse & Filtering |
| Ambient Temperature | | | 50 | deg C | Operating Ambient Temperature (deg Celsius) |
| Switching Topology | | | Buck | | Type of Switching topology |
| Input Rectification Type | H | | H | | Choose H for Half Wave Rectifier and F for Full Wave Rectification |
| DC INPUT VARIABLES | | | | | |
| VMIN | | | 86.6 | Volts | Minimum DC Bus Voltage |
| VMAX | | | | | |
| LinkSwitch-TN | | | | | |
| LinkSwitch-TN | Auto | | LNK3204 | | Selected LinkSwitch-TN. Ordering info - Suffix P/G indicates DIP 8 package; suffix D indicates SO8 package; second suffix N indicates lead free RoHS compliance |
| ILIMIT | | | 0.257 | Amps | Typical Current Limit |
| ILIMIT_MIN | | | 0.240 | Amps | Minimum Current Limit |
| ILIMIT_MAX | | | 0.275 | Amps | Maximum Current Limit |
| FSMIN | | | 62000 | Hertz | Minimum Switching Frequency |
| VDS | | | | | |
| PLOSS_LNK | | | 0.33 | Watts | Estimated LinkSwitch-TN losses |
| DIODE | | | | | |
| VD | | | 0.70 | Volts | Freewheeling Diode Forward Voltage Drop |
| VRR | | | 600 | Volts | Recommended PIV rating of Freewheeling Diode |
| IF | | | | | |
| TRR | | | 75 | ns | Recommended Reverse Recovery Time |
| Diode Recommendation | | | UF4005 | | Suggested Freewheeling Diode |
| OUTPUT INDUCTOR | | | | | |
| L_TYP | | | 925.1 | uH | Required value of Inductance to deliver Output Power (Includes device and inductor tolerances) Choose next higher standard available value |
| L | | | 1000 | uH | Output Inductor, Recommended Standard Value |
| L_R | | | 2.0 | Ohms | DC Resistance of Inductor |
| OPERATING MODE | | | MDCM | | Mostly Discontinuous Conduction Mode (at VMIN) |
| KL_TOL | | | | | |
| K_LOSS | | | 0.833 | | Loss factor. Accounts for "off-state" power loss to be supplied by inductor Calculated efficiency < K_LOSS < 1. See AN-37 for detailed explanation |
| ILRMS | | | 0.13 | Amps | Estimated RMS inductor current (at VMAX) |
| OUTPUT CAPACITOR | | | | | |
| DELTA_V | | | | | |
| MAX_ESR | | | 500 | m-Ohms | Maximum Capacitor ESR (milli-ohms) |
| I_RIPPLE | | | 0.24 | Amps | Output Capacitor Ripple current |



8 Performance Data

All measurements performed at room temperature.

8.1 Efficiency vs. Line

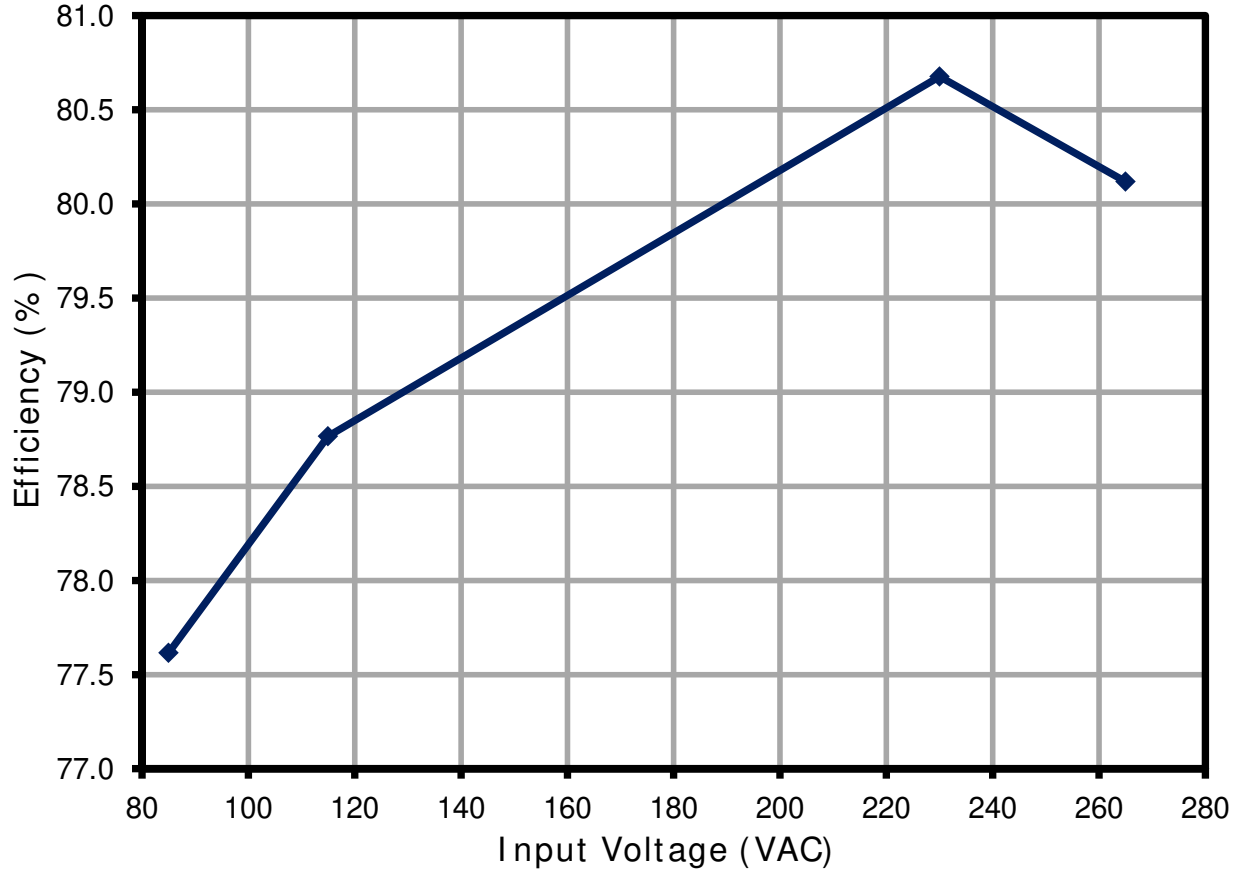

Figure 6– Efficiency vs. Line Voltage, Room temperature.



8.2 Efficiency vs. Load

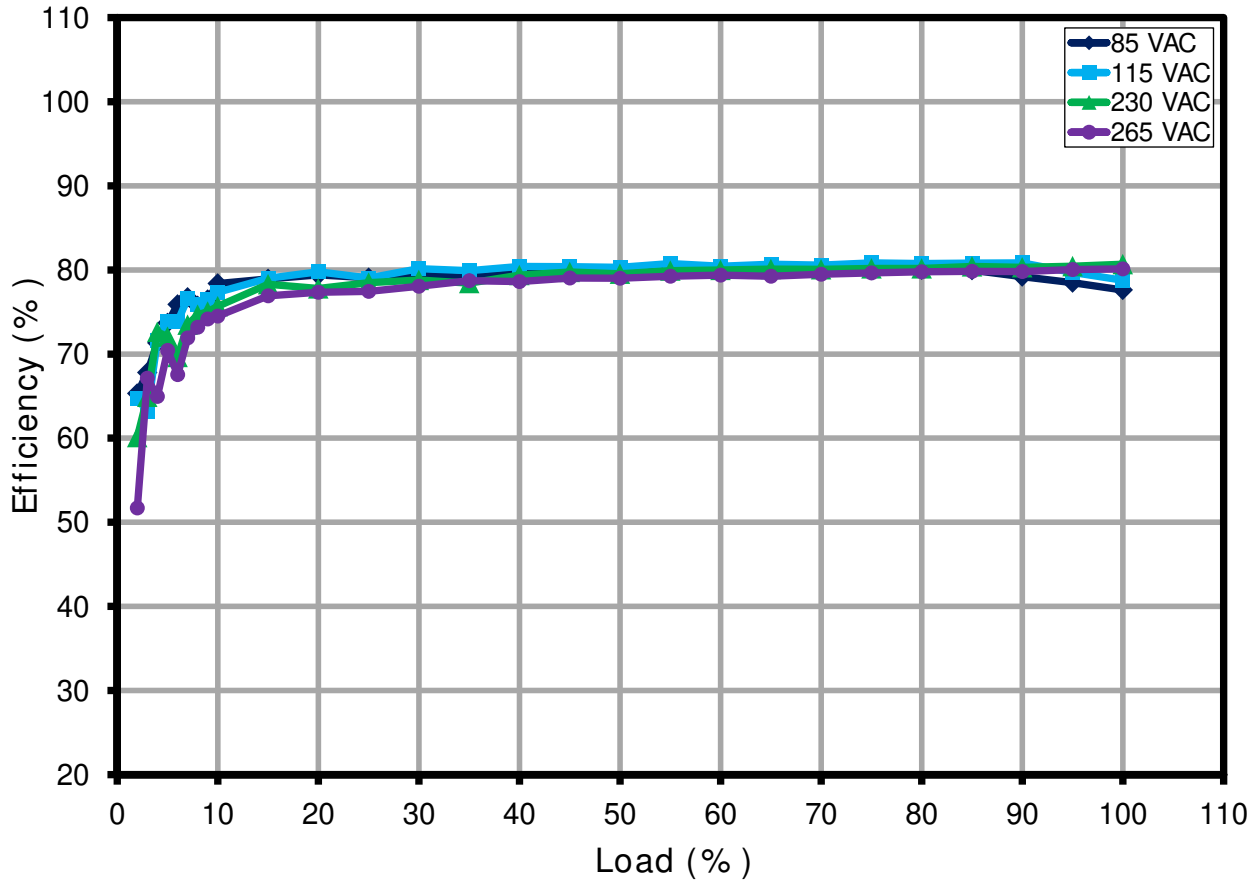

Figure 7 – Efficiency vs. Load, Room temperature.

8.3 *No-Load Input Power*

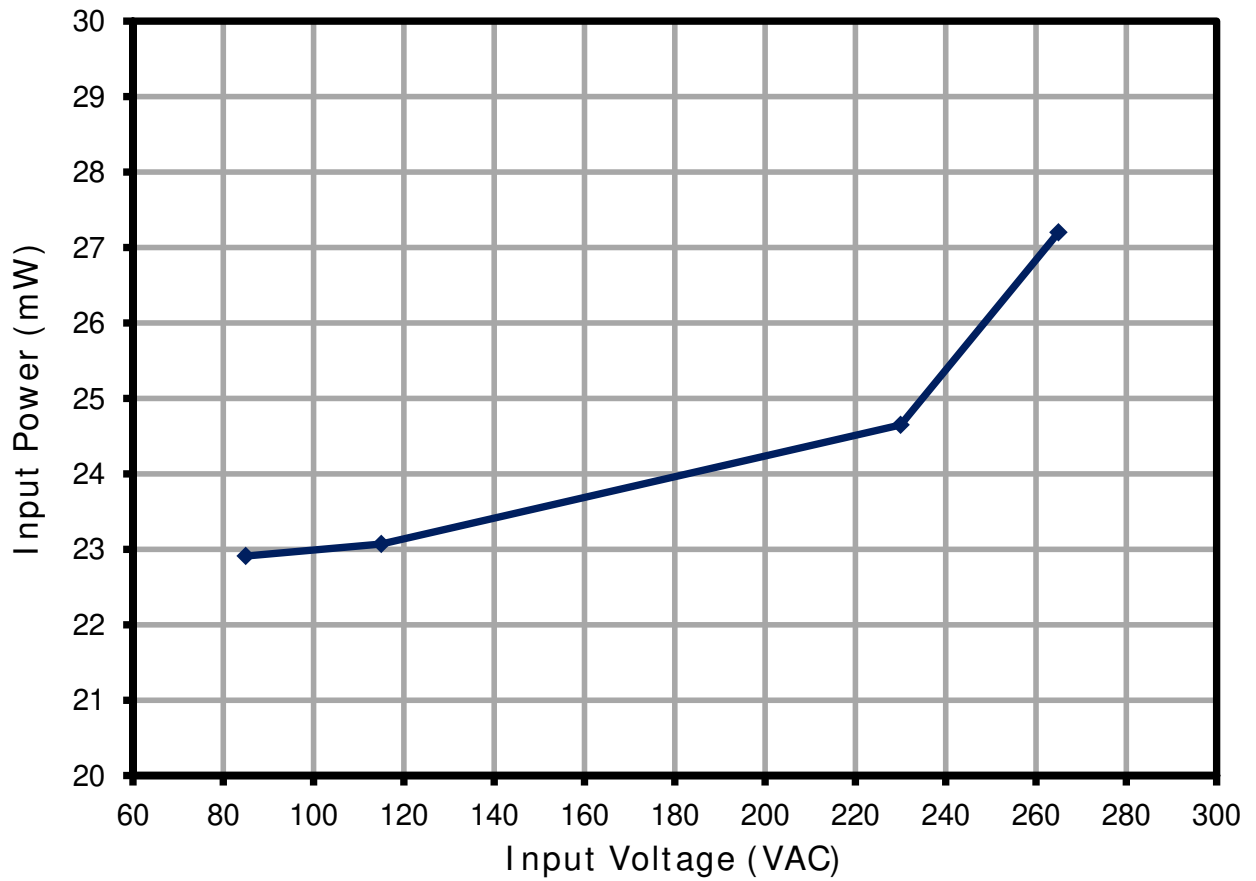

Figure 8 – No-Load Input Power vs. Input Line Voltage, Room Temperature.



8.4 Load Regulation

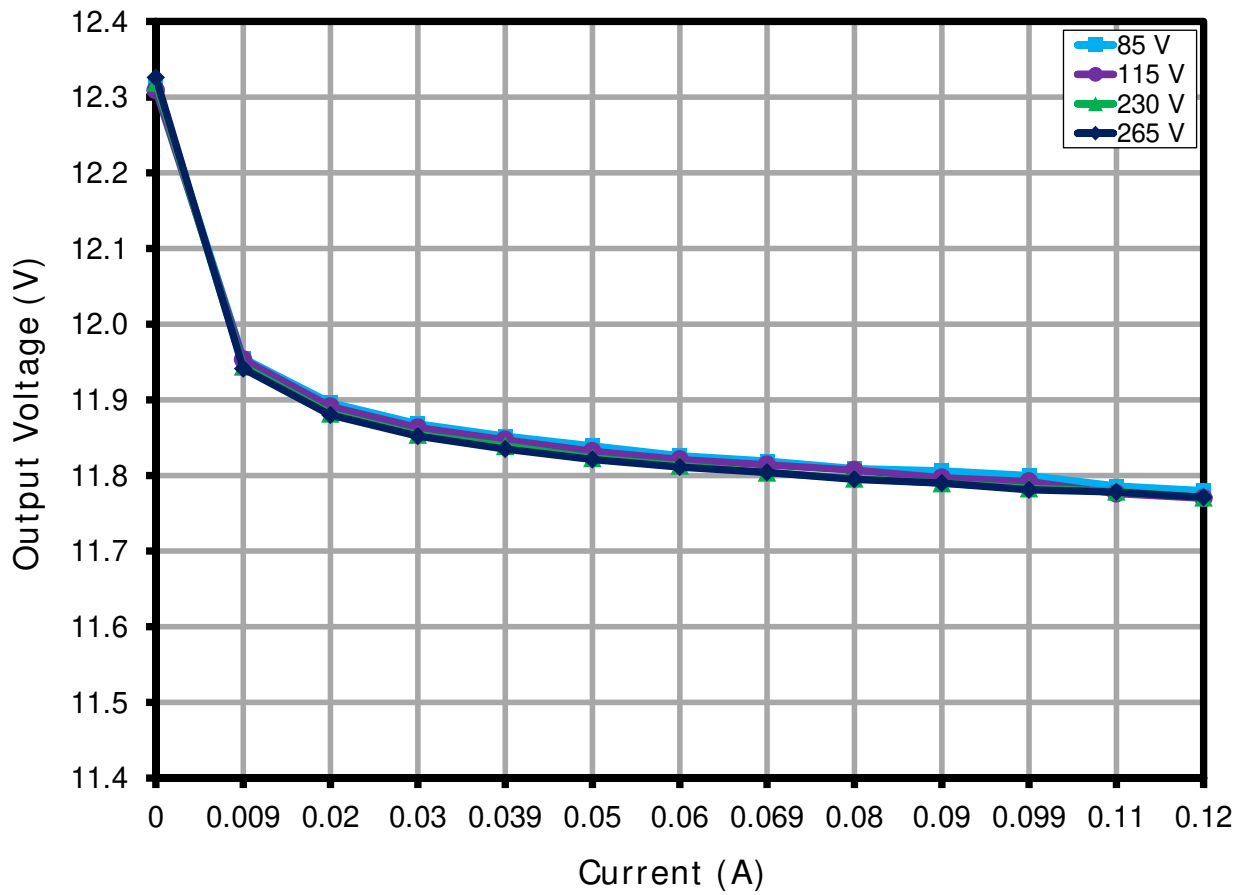

Figure 9 – Output Voltage vs. Output current, Room Temperature.

8.5 *Line Regulation at Full Load*

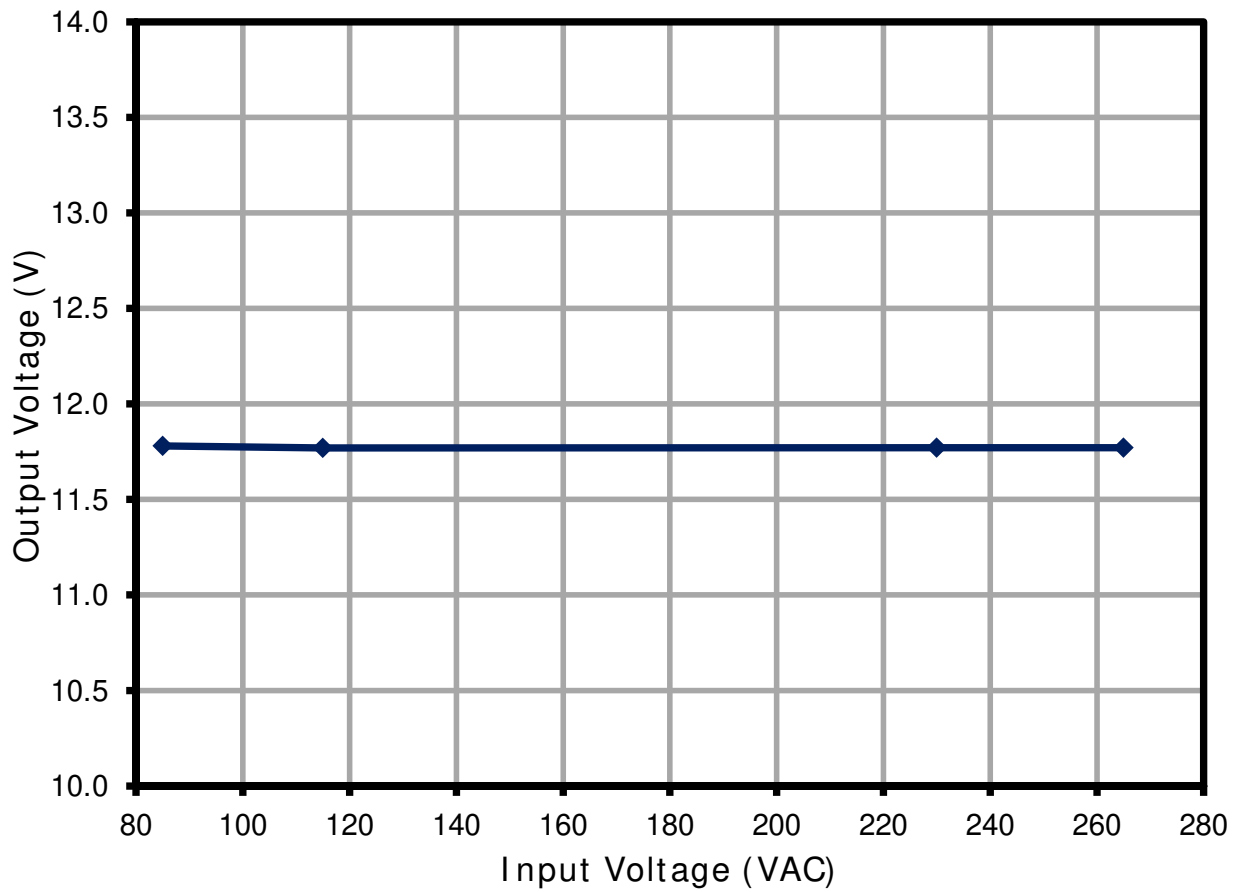

Figure 10 – Output Voltage vs. Input Voltage, Room Temperature.



9 Open Case Thermal Performance

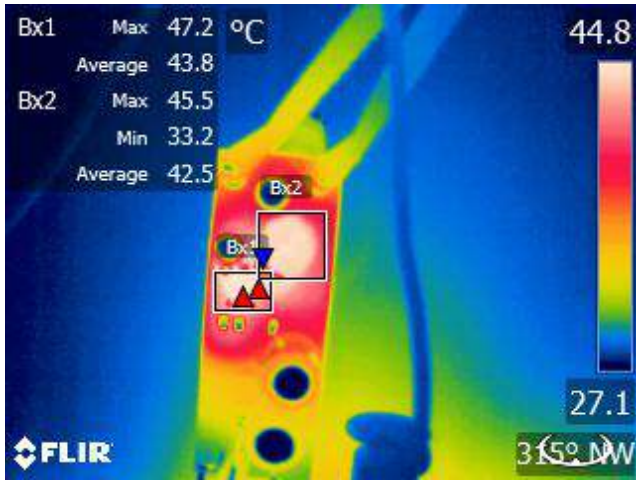

Figure 11 – LNK3204D Maximum 47.2 °C.
85 VAC, 120 mA Load.
Ambient = 27 °C.

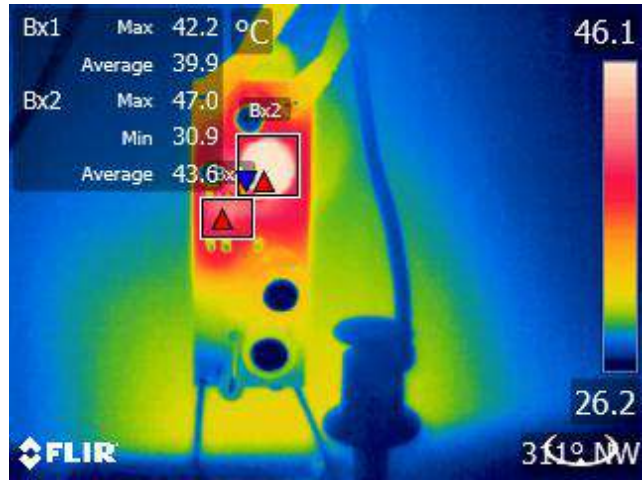

Figure 12 – LNK3204D Maximum 42.2 °C.
265 VAC, 120 mA Load.
Ambient = 26.3 °C.

10 Waveforms

10.1 Switching Waveforms

10.1.1 LNK3204D Waveforms

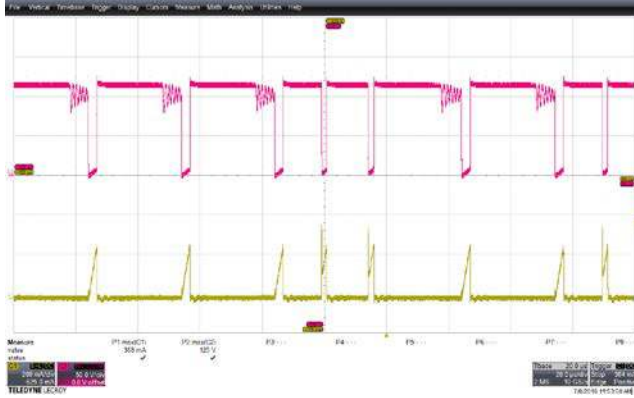

Figure 13 – Drain Voltage and Current Waveforms.
85 VAC, 120 mA Output.
Upper: V_{DRAIN} , 50 V, 20 μ s / div.
Lower: I_{DRAIN} , 200 mA / div.

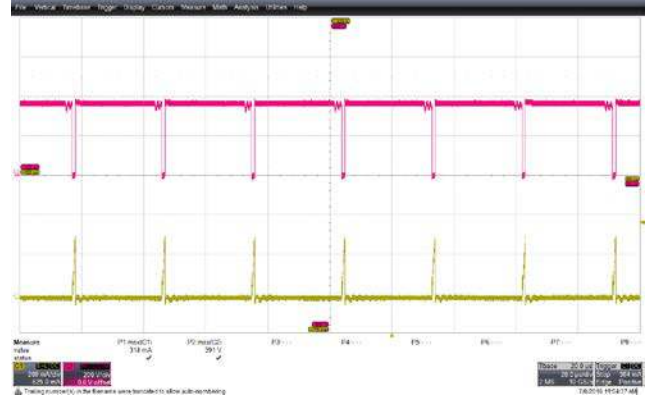

Figure 14 – Drain Voltage and Current Waveforms.
265 VAC, 120 mA Output.
 $V_{DS(Max)}$: 391 V.
Upper: V_{DRAIN} , 200 V, 20 μ s / div.
Lower: I_{DRAIN} , 200 mA / div.

10.1.2 LNK3204D Drain Voltage and Current Waveforms During Start-up

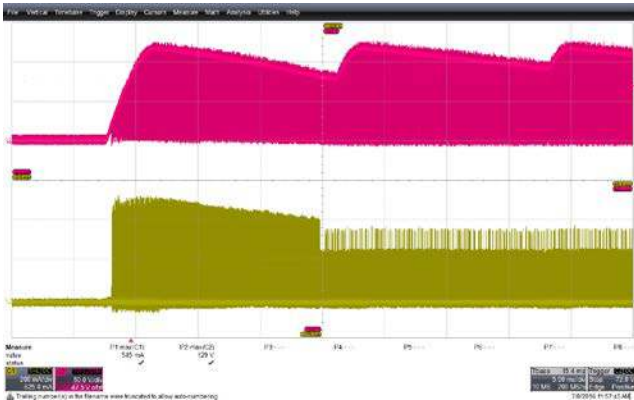

Figure 15 – Drain Voltage and Current Waveforms.
85 VAC, 120 mA Output.
Upper: V_{DRAIN} , 50 V, 5 ms / div.
Lower: I_{DRAIN} , 200 mA / div.

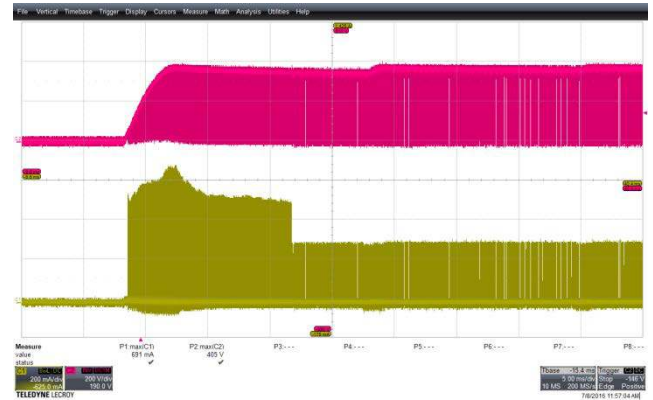

Figure 16 – Drain Voltage and Current Waveforms.
265 VAC, 120 mA Output.
 $V_{DS(MAX)}$: 405 V.
Upper: V_{DRAIN} , 200 V, 5 ms / div.
Lower: I_{DRAIN} , 200 mA / div.

10.1.3 Drain Current and Output Waveform During Output Short

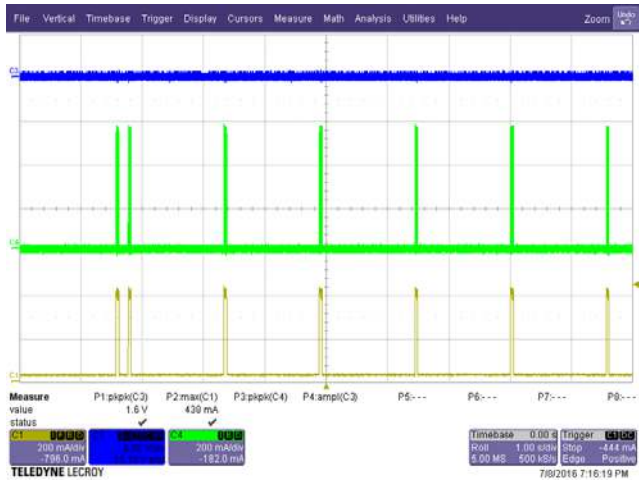

Figure 17 – Drain Current and Output Waveforms.
85 VAC Input.
Upper: V_{OUT} , 5 V, 1s / div.
Middle: I_{DRAIN} , 200 mA / div.
Lower: I_{OUT} , 200 mA / div.

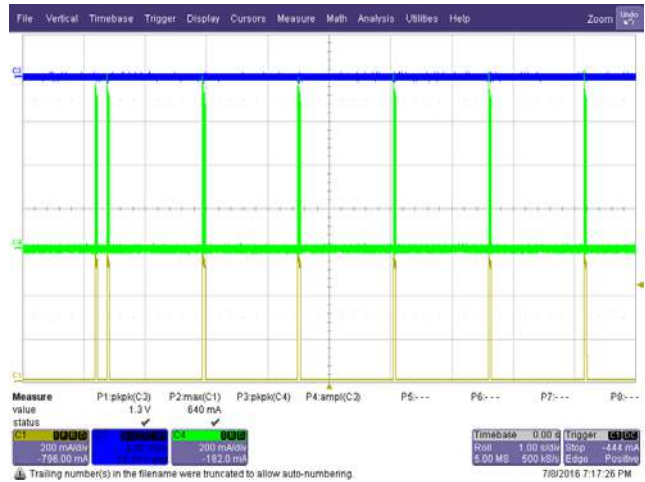

Figure 18 – Drain Voltage and Output Waveforms.
265 VAC Input.
Upper: V_{OUT} , 5 V, 1s / div.
Middle: I_{DRAIN} , 200 mA / div.
Lower: I_{OUT} , 200 mA / div.

10.1.4 Freewheeling Diode Waveforms

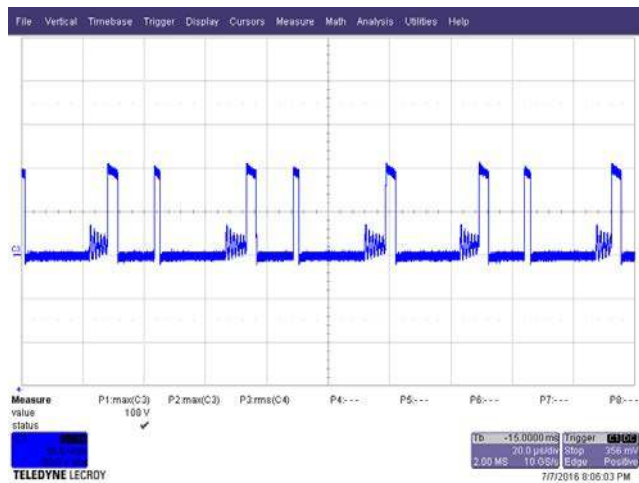

Figure 19 – Freewheeling Diode Voltage Waveforms.
85 VAC, 120 mA Output.
50 V, 20 μ s / div.

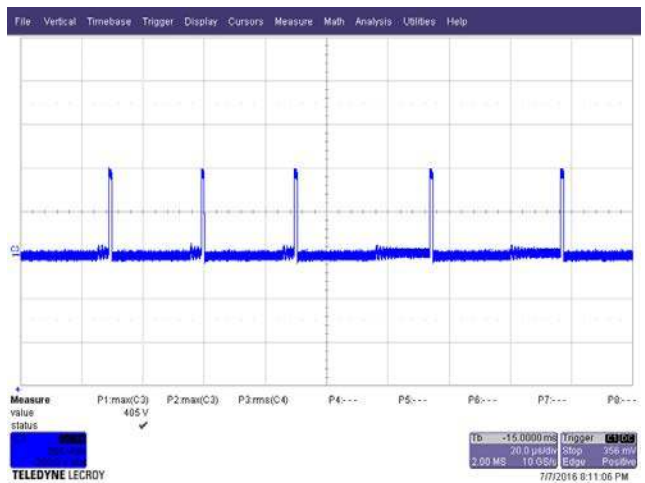

Figure 20 – Freewheeling Diode Voltage Waveforms.
265 VAC, 120 mA Output.
 V_{MAX} : 405 V.
200 V, 20 μ s / div.

10.1.5 Output Voltage and Current Waveforms During Start-Up

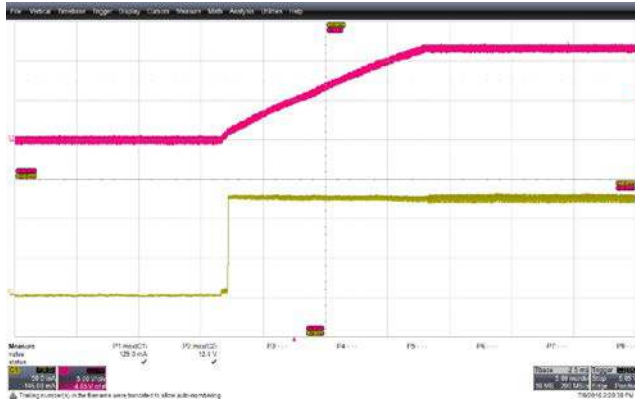

Figure 21 – Output Voltage and Current Waveforms.
 85 VAC, 120 mA Output.
 Blue: I_{DRAIN} , 50 mA / div.
 Yellow: V_{DRAIN} , 5 V / div., 5 ms / div.

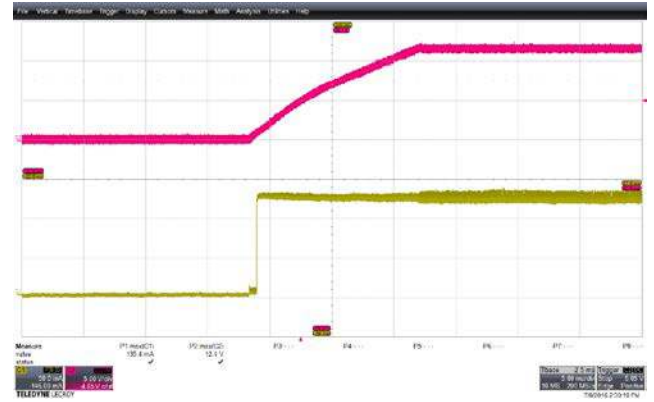

Figure 22 – Output Voltage and Current Waveforms.
 265 VAC, 120 mA Output.
 Blue: I_{DRAIN} , 50 mA / div.
 Yellow: V_{DRAIN} , 5 V / div., 5 ms / div.

10.2 Output Ripple Measurements

11.2.1 Ripple Measurement Technique

For DC output ripple measurements, a modified oscilloscope test probe must be utilized in order to reduce spurious signals due to pick-up. Details of the probe modification are provided in the Figures below.

The 4987BA probe adapter is affixed with two capacitors tied in parallel across the probe tip. The capacitors include one (1) 0.1 μF /50 V ceramic type and one (1) 1 μF /50 V aluminum electrolytic. The aluminum electrolytic type capacitor is polarized, so proper polarity across DC outputs must be maintained (see below).

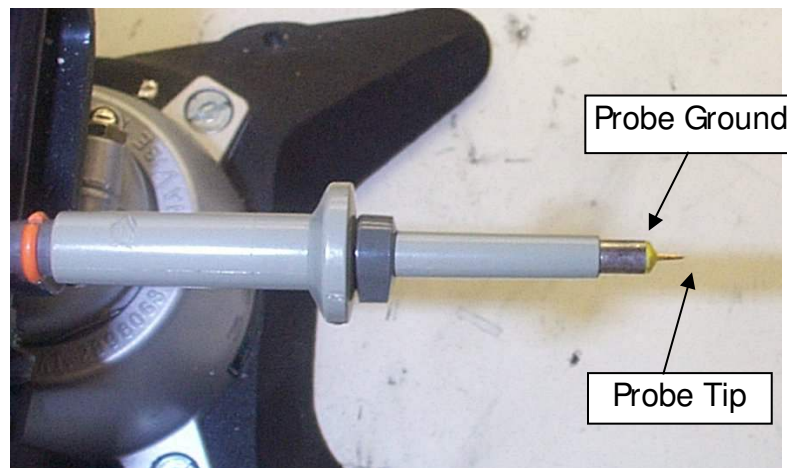

Figure 23 – Oscilloscope Probe Prepared for Ripple Measurement. (End Cap and Ground Lead Removed)



Figure 24 – Oscilloscope Probe with Probe Master (www.probemaster.com) 4987A BNC Adapter. (Modified with wires for ripple measurement, and two parallel decoupling capacitors added)

10.2.2 Measurement Results

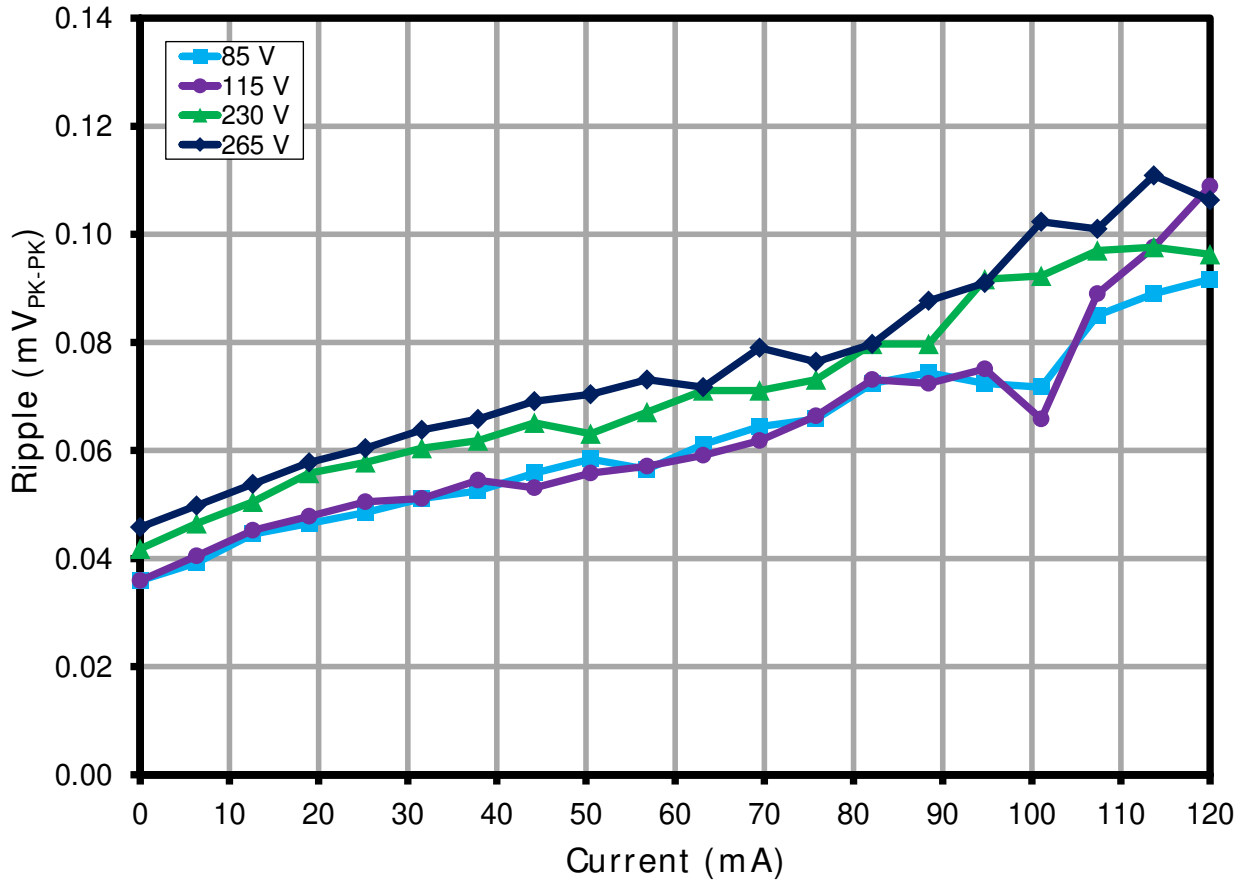

Figure 25 – Output Ripple Voltage.

| 85 V | 115 V | 230 V | 265 V |
|-------------------------------|-------------------------------|-------------------------------|-------------------------------|
| RI PPLE (V _{PK-PK}) | RI PPLE (V _{PK-PK}) | RI PPLE (V _{PK-PK}) | RI PPLE (V _{PK-PK}) |
| 0.092 | 0.109 | 0.096 | 0.106 |



10.2.3 Ripple Voltage Waveforms

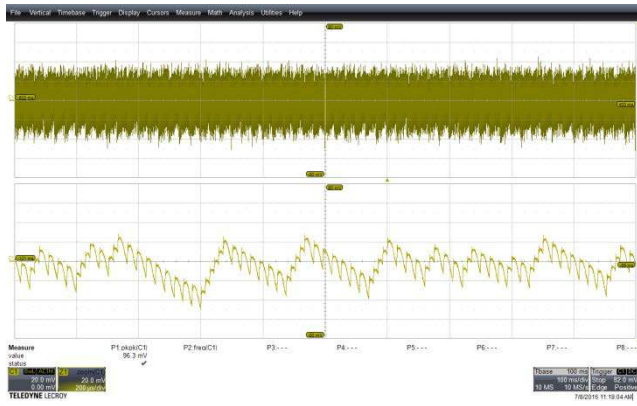

Figure 26 – Output Voltage Ripple Waveforms.
85 VAC, 120 mA Output.
20 mV, 100 ms / div.; 200 μ s / div.
 $V_{PK-PK}: 96.3\text{ mV}$.

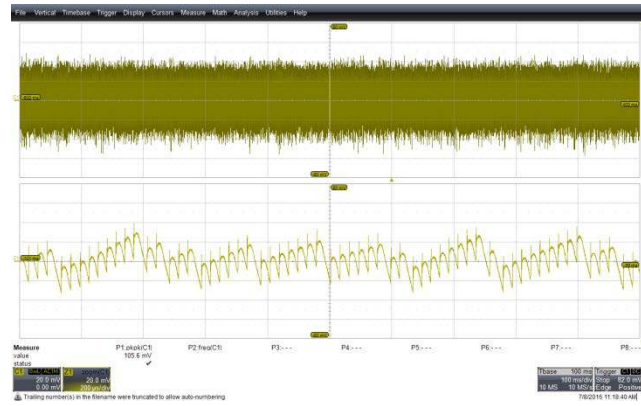

Figure 27 – Output Voltage Ripple Waveforms.
265 VAC, 120 mA Output.
20 mV, 100 ms / div.; 200 μ s / div.
 $V_{PK-PK}: 105.6\text{ mV}$.

11 Conductive EMI

11.1 120 mA Resistive Load, Floating Output (QPK / AV)

After running for 5 minutes.

11.1.1 Line

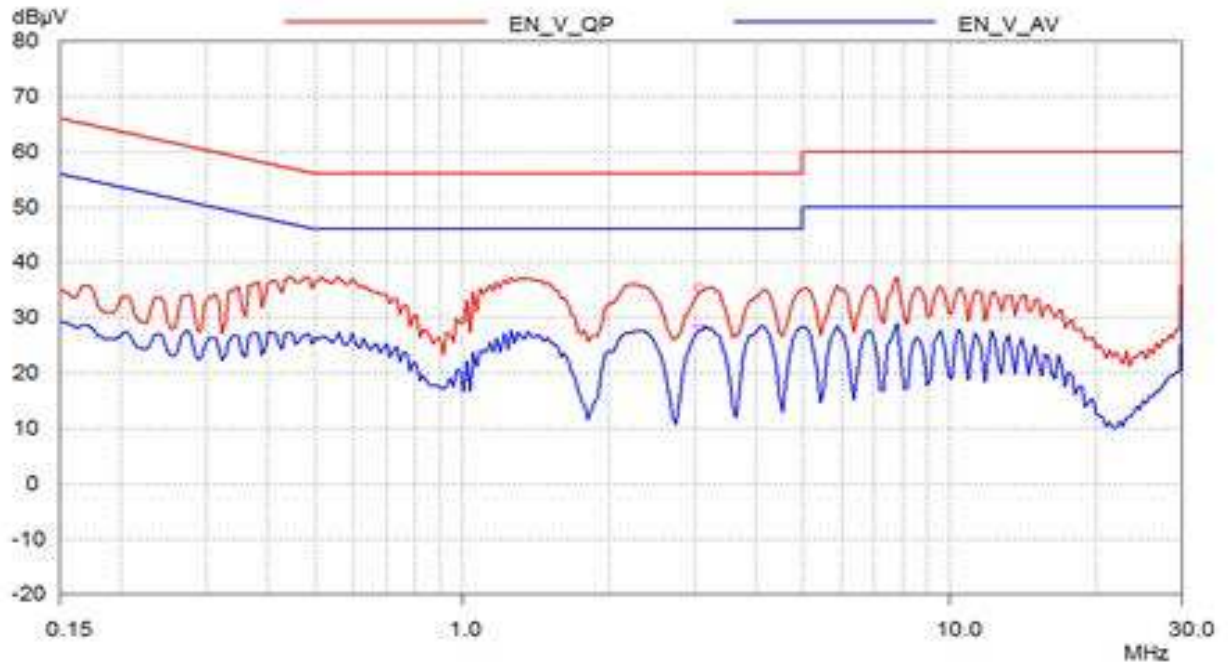

Figure 28 – Floating Ground EMI at 230 VAC.

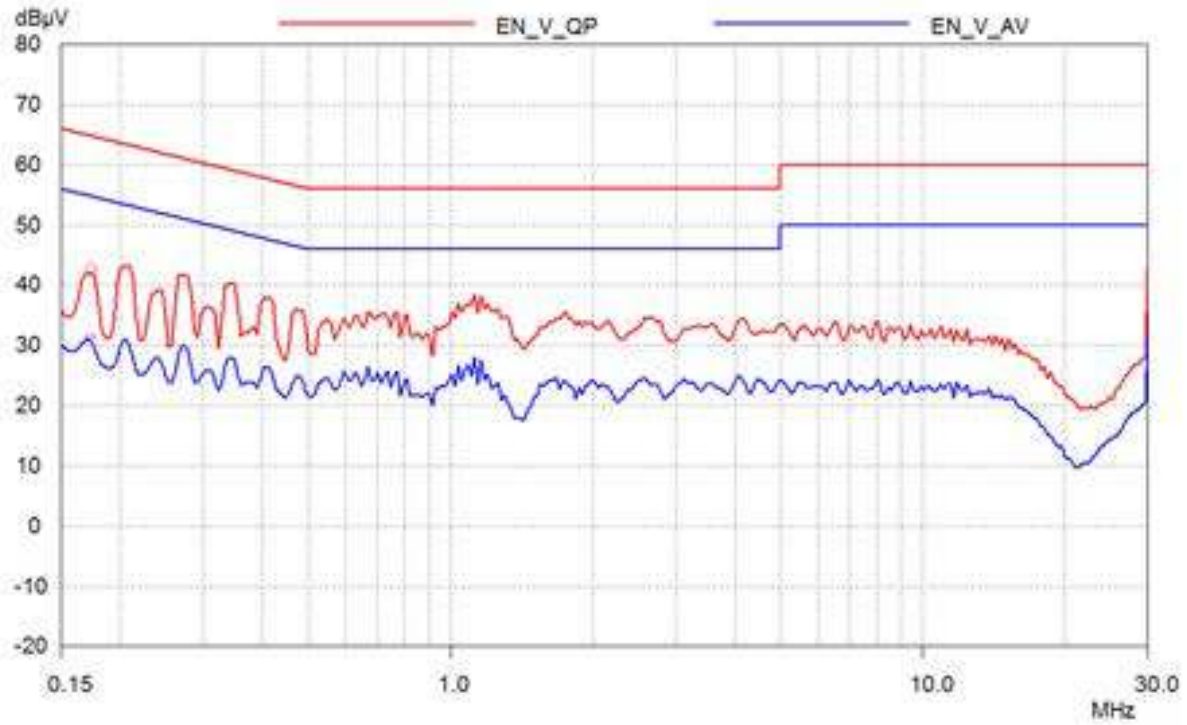

Figure 29 – Floating Ground at 115 VAC.

11.1.2 Neutral

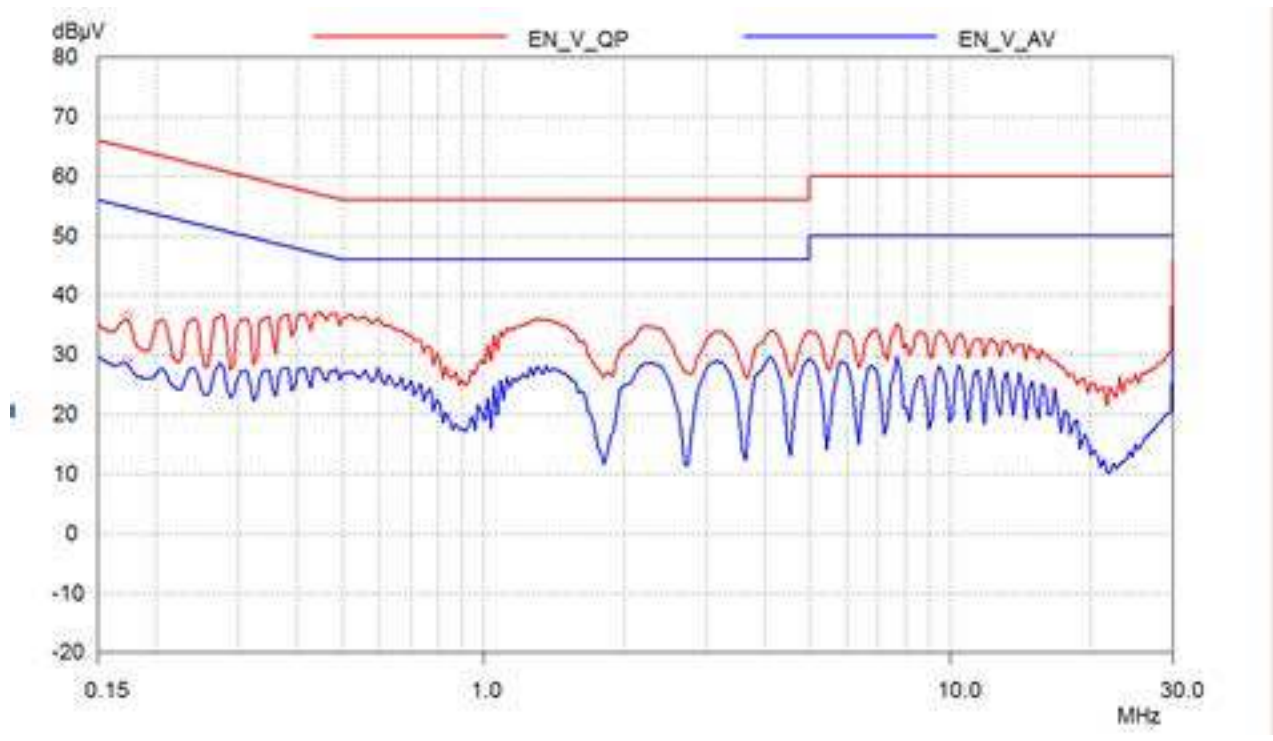

Figure 30 – Floating Ground at 230 VAC.



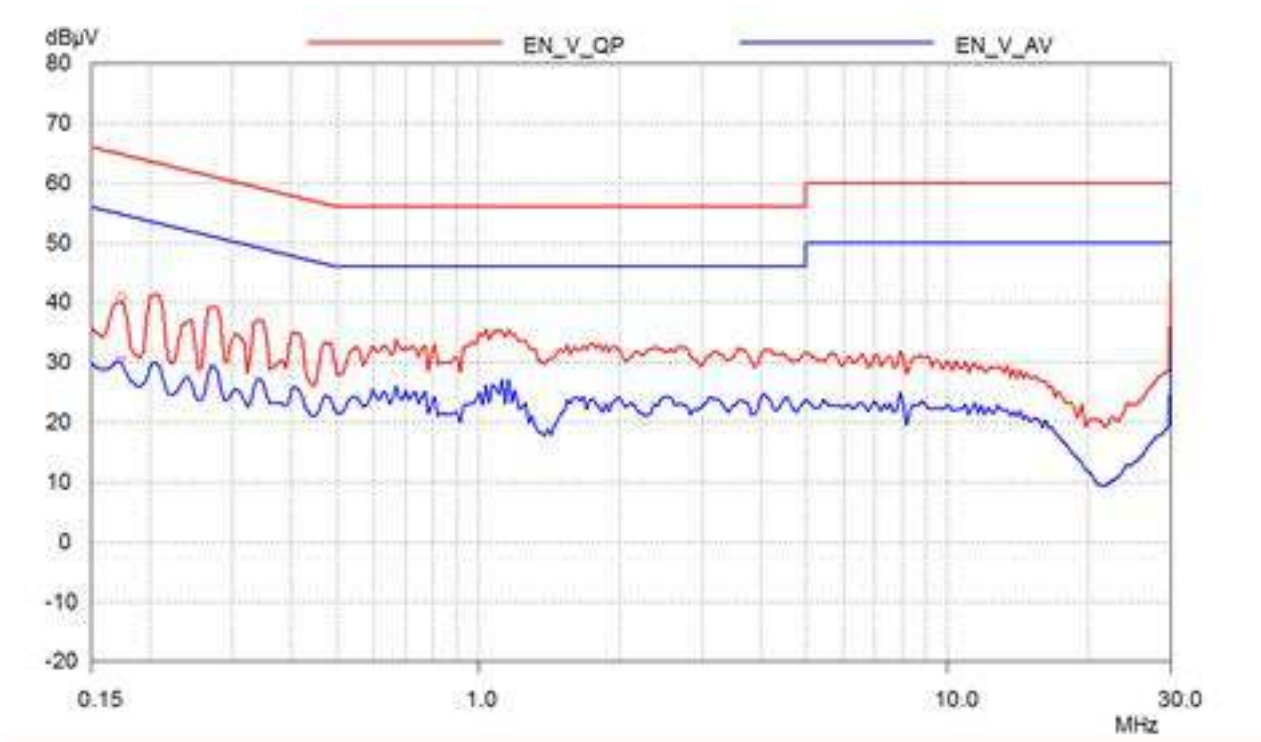

Figure 31 – Floating Ground at 115 VAC.

12 Lighting Surge

12.1 *Differential Mode Test*

Passed ± 1 kV surge test.



13 Revision History

| Date | Author | Revision | Description & Changes | Reviewed |
|-----------|--------|----------|-----------------------|-------------|
| 08-Nov-16 | JW | 1.0 | Initial Release. | Apps & Mktg |
| | | | | |
| | | | | |



For the latest updates, visit our website: www.power.com

Power Integrations reserves the right to make changes to its products at any time to improve reliability or manufacturability. Power Integrations does not assume any liability arising from the use of any device or circuit described herein. POWER INTEGRATIONS MAKES NO WARRANTY HEREIN AND SPECIFICALLY DISCLAIMS ALL WARRANTIES INCLUDING, WITHOUT LIMITATION, THE IMPLIED WARRANTIES OF MERCHANTABILITY, FITNESS FOR A PARTICULAR PURPOSE, AND NON-INFRINGEMENT OF THIRD PARTY RIGHTS.

PATENT INFORMATION

The products and applications illustrated herein (including transformer construction and circuits' external to the products) may be covered by one or more U.S. and foreign patents, or potentially by pending U.S. and foreign patent applications assigned to Power Integrations. A complete list of Power Integrations' patents may be found at www.power.com. Power Integrations grants its customers a license under certain patent rights as set forth at <http://www.power.com/ip.htm>.

The PI Logo, TOPSwitch, TinySwitch, LinkSwitch, LYTSwitch, InnoSwitch, DPA-Switch, PeakSwitch, CAPZero, SENZero, LinkZero, HiperPFS, HiperTFS, HiperLCS, Qspeed, EcoSmart, Clampless, E-Shield, Filterfuse, FluxLink, StackFET, PI Expert and PI FACTS are trademarks of Power Integrations, Inc. Other trademarks are property of their respective companies. © Copyright 2015 Power Integrations, Inc.

Power Integrations Worldwide Sales Support Locations

WORLD HEADQUARTERS

5245 Hellyer Avenue
San Jose, CA 95138, USA
Main: +1-408-414-9200
Customer Service:
Phone: +1-408-414-9665
Fax: +1-408-414-9765
e-mail: usasales@powerint.com

GERMANY

Lindwurmstrasse 114
80337, Munich
Germany
Phone: +49-895-527-39110
Fax: +49-895-527-39200
e-mail: eurosales@powerint.com

JAPAN

Kosei Dai-3 Building
2-12-11, Shin-Yokohama,
Kohoku-ku, Yokohama-shi,
Kanagawa 222-0033
Japan
Phone: +81-45-471-1021
Fax: +81-45-471-3717
e-mail: japansales@powerint.com

TAI WAN

5F, No. 318, Nei Hu Rd.,
Sec. 1
Nei Hu District
Taipei 11493, Taiwan R.O.C.
Phone: +886-2-2659-4570
Fax: +886-2-2659-4550
e-mail: taiwansales@powerint.com

CHINA (SHANGHAI)

Rm 2410, Charity Plaza, No. 88,
North Caoxi Road,
Shanghai, PRC 200030
Phone: +86-21-6354-6323
Fax: +86-21-6354-6325
e-mail: chinasales@powerint.com

INDIA

1, 14th Main Road
Vasanthanagar
Bangalore-560052
India
Phone: +91-80-4113-8020
Fax: +91-80-4113-8023
e-mail: indiasales@powerint.com

KOREA

RM 602, 6FL
Korea City Air Terminal B/D,
159-6
Samsung-Dong, Kangnam-Gu,
Seoul, 135-728 Korea
Phone: +82-2-2016-6610
Fax: +82-2-2016-6630
e-mail: koreasales@powerint.com

UK

First Floor, Unit 15, Meadway
Court, Rutherford Close,
Stevenage, Herts. SG1 2EF
United Kingdom
Phone: +44 (0) 1252-730-141
Fax: +44 (0) 1252-727-689
e-mail: eurosales@powerint.com

CHINA (SHENZHEN)

17/F, Hivac Building, No. 2, Keji
Nan 8th Road, Nanshan District,
Shenzhen, China, 518057
Phone: +86-755-8672-8689
Fax: +86-755-8672-8690
e-mail: chinasales@powerint.com

ITALY

Via Milanese 20, 3rd Fl.
20099 Sesto San Giovanni
(MI) Italy
Phone: +39-024-550-8701
Fax: +39-028-928-6009
e-mail: eurosales@powerint.com

SINGAPORE

51 Newton Road,
19-01/05 Goldhill Plaza
Singapore, 308900
Phone: +65-6358-2160
Fax: +65-6358-2015
e-mail: singaporesales@powerint.com

