

PC BOARD VERSIONS		
PRODUCT NR	PCB THICKNESS	DIM A
63791-X02	1.6	2.73
63791-X12	2.4 OR 3.2	3.53
63791-X02LF	1.6	2.73
63791-X12LF	2.4 OR 3.2	3.53

PRESS-FIT HOLES	
HOLE DIAMETER	
AFTER PLATING	0.65-0.80
DRILLED HOLE	0.81-0.86
COPPER PLATING	0.025 MIN.
SnPb PLATING	0.005-0.015

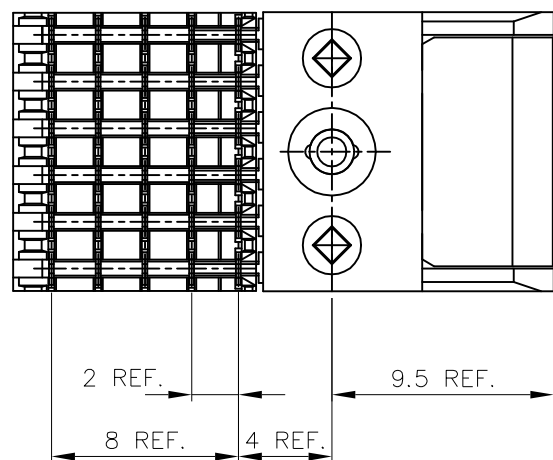
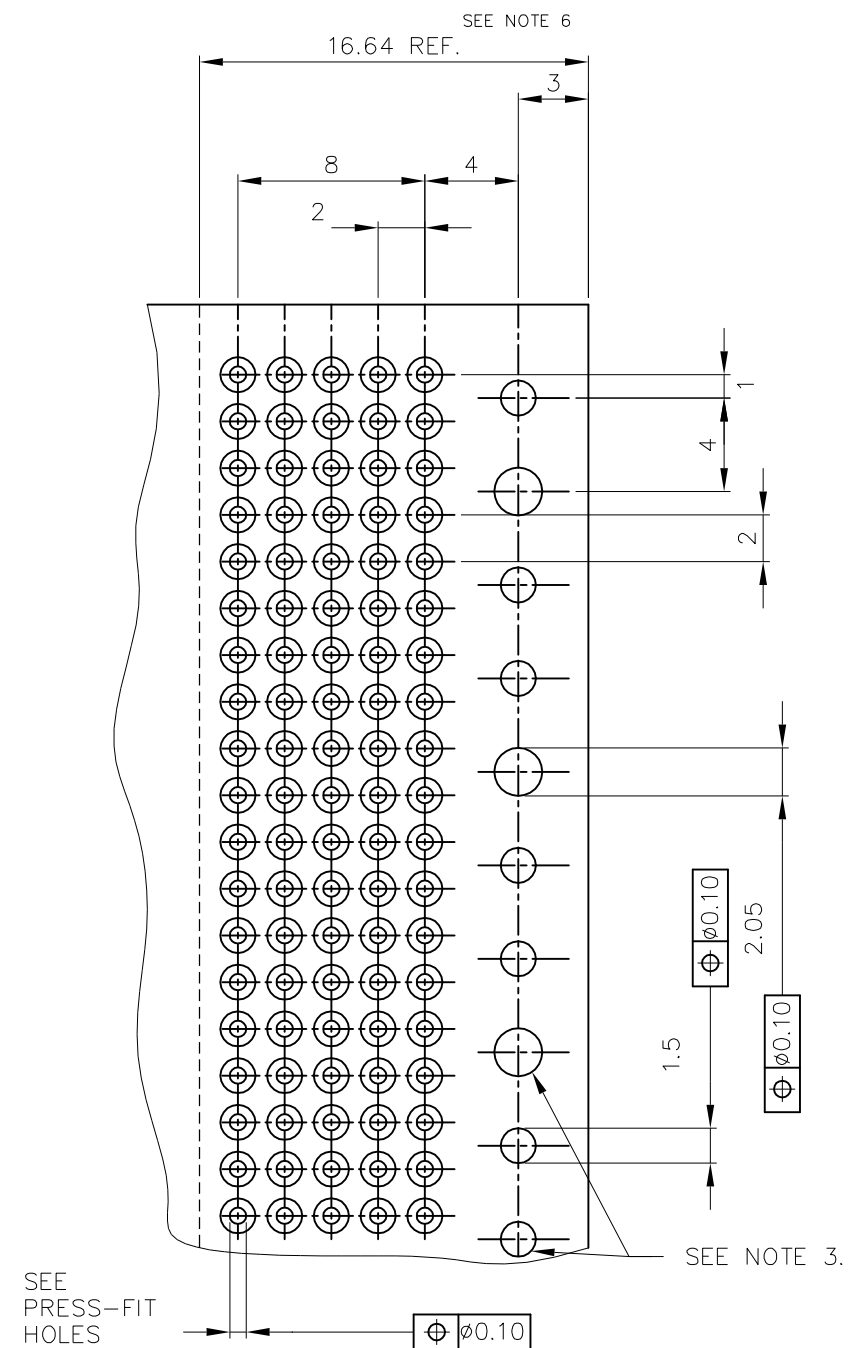
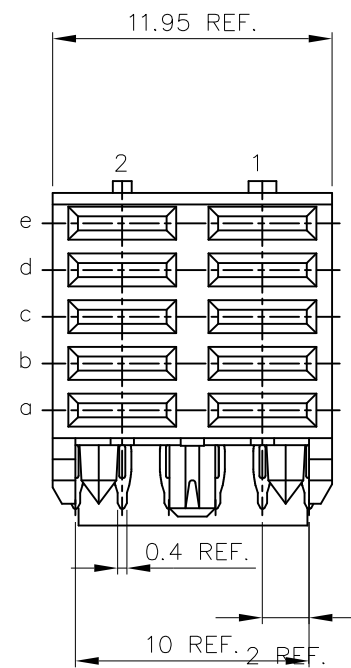
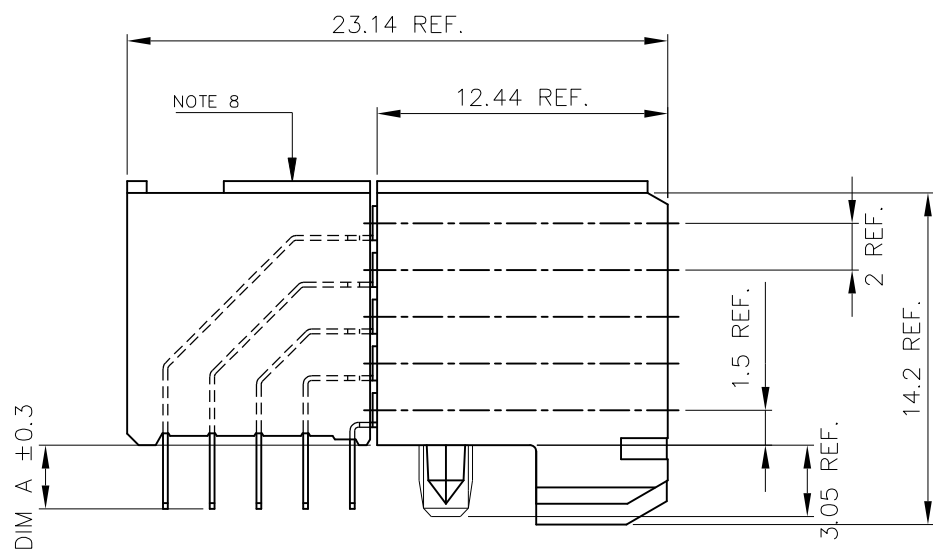

- NOTES:
- 1 BODY MAT'L: LIQUID CRYSTAL POLYMER 30% GLASS  
FLAME RETARDANT ACC. UL 94-V0
  - 2 TERMINAL MATERIAL: PHOSPHOR BRONZE.
  - 3 INDICATED HOLES ARE UNPLATED.
  - 4 PLATING OF COMPLIANT SECTIONS 0.5-1.5 mm SnPb 85-97  
OR 0.5-1.5 mm PURE Sn FOR LF.
  - 5 PRODUCT MARKING: PART NUMBER & BATCH ID.
  - 6 SET BACK FOR PRESS BLOCK
  - 7 SEE TA-941 FOR -XY2/XY2LF APPLICATION TOOLING
  - 8 TOP SURFACE OF PRESS BLOCK MAY EXTEND UP TO 0.4MM  
HIGHER THAN HOUSING. THIS MAY AFFECT THE TAIL LENGTH  
BEFORE APPLICATION TO A BOARD.
  - 9 THIS PRODUCT WITH "LF" SUFFIX MEETS EUROPEAN UNION DIRECTIVES  
AND OTHER COUNTRY REGULATIONS AS DESCRIBED IN GS -22-008.
  - 10 THE PRODUCT IS NOT INTENDED TO BE EXPOSED TO A MANUFACTURE  
AND SOLDER PROCESS.

PRODUCT NR	PLATING CONTACT AREA	UNDERPLATING
63791-1Y2/1Y2LF	0.76 um GOLD OR GXT	1.3 um Ni min.
63791-2Y2/2Y2LF	2.0 um GOLD	1.3 um Ni min.
63791-3Y2/3Y2LF	1.3 um GOLD	1.3 um Ni min.
63791-9Y2/9Y2LF	0.76 um GXT	1.3 um Ni min.

mat'l. code				surface ISO 1302		tolerance ISO 406 ISO 1101		projection MM		product family METRAL (tm)	
ltr ecn no dr date				tolerances unless otherwise specified		angles linear		scale 1.5:1		title 5R RECEPTACLE POWER RA PF 12mm ASSEMBLY	
A	v11875	JWS	07/16/01							dwg no 63791	
B	DG05-0342	CLU	092005							sheet 1 of 1 size A3	
C	DG08-0171	Cenh	10/08/08							type Product Customer Drawing	
D	ELX-N-26608	MZ	04/11/17								
sheet index				revision D							
sheet 1											