



EVQ3369-R-01A

6-Channel, Max 100mA/Ch Boost WLED Driver with 15000:1 Dim Ratio and I²C Evaluation Board

DESCRIPTION

The EVQ3369-R-01A is an evaluation board for the MPQ3369, which is a step-up converter with six channel current sources. It is designed for driving the white LED arrays as backlighting for mid- or small-sized LCD panels.

The MPQ3369 uses peak-current mode as its PWM control architecture to regulate the boost converter. Six channel current sources are applied to the LED cathode to adjust the LED brightness. It regulates the current in each LED string to the value set by an external current-setting resistor, with 2.5% current regulation accuracy between strings.

The IC employs a low on-resistance MOSFET and a low headroom voltage design to achieve high efficiency. It has a standard I²C digital interface for easy use. The switching frequency can be programmed by a resistor, the I²C interface, or an external clock.

The MPQ3369 provides analog, PWM, and mix dimming mode with PWM input. The dimming mode can be selected via the I²C interface or the MIX/AD pin. It also offers a phase shift function to eliminate noise when PWM dimming.

Protections features designed to guarantee safe operation include over-current protection (OCP), over-voltage protection (OVP), over-temperature protection (OTP), LED short and open protection. The LED current also automatically decreases at high temperatures.

The MPQ3369 is available in QFN-24 (4mmx4mm) and TSSOP-28EP packages.

ELECTRICAL SPECIFICATIONS

Parameter	Symbol	Value	Units
Input voltage	V _{IN}	12	V
Output voltage	V _{LED}	<50	V
LEDs#		6 strings	
LED current /string	I _{LED}	50	mA

FEATURES

- 3.5V to 36V Input Voltage Range
- 6 Channels with Max 100mA per Channel
- Internal 100mΩ, 50V MOSFET
- Programmable Up to 2.2MHz f_{SW}
- External Sync SW Function
- Multi-Dimming Operation Mode through PWM Input, including:
 - Direct PWM Dimming
 - Analog Dimming
 - Mix Dimming with 25%/12.5% Transfer Point
- 15000:1 Dim Ratio in PWM Dimming at f_{PWM} ≤ 200Hz
- 200:1 Dim Ratio at Analog Dim through PWM Dimming Signal Input
- Excellent EMI Performance
- Frequency Spread Spectrum
- I²C Interface
- Phase Shift Function for PWM Dimming
- 2.5% Current Matching
- Cycle-by-Cycle Current Limiting
- Disconnect V_{OUT} from V_{IN}
- LED Current Auto-Decrement at High Temperatures
- LED Short/Open, OTP, OCP, and Inductor Short Protections
- Programmable LED Short and OVP Thresholds
- Fault Indicator Signal Output
- Available in QFN-24 (4mmx4mm) and TSSOP-28EP Packages

APPLICATIONS

- Tablets/Notebooks
- Automotive Displays

All MPS parts are lead-free, halogen-free, and adhere to the RoHS directive. For MPS green status, please visit the MPS website under Quality Assurance. "MPS", the MPS logo, and "Simple, Easy Solutions" are trademarks of Monolithic Power Systems, Inc. or its subsidiaries.

EVQ3369-R-01A EVALUATION BOARD

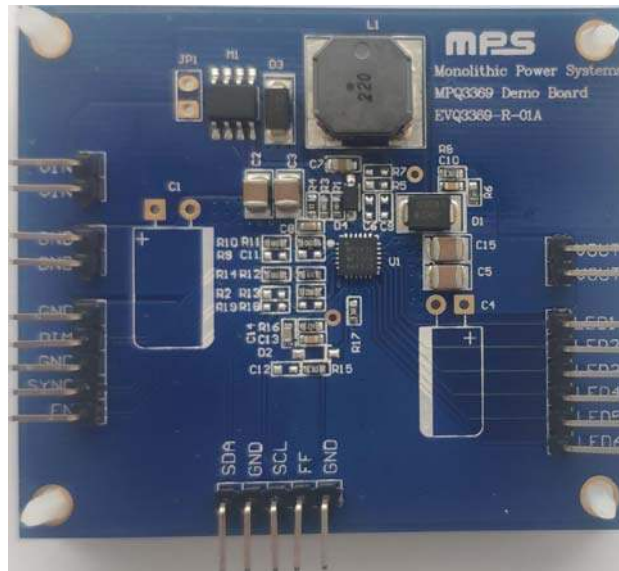

Top

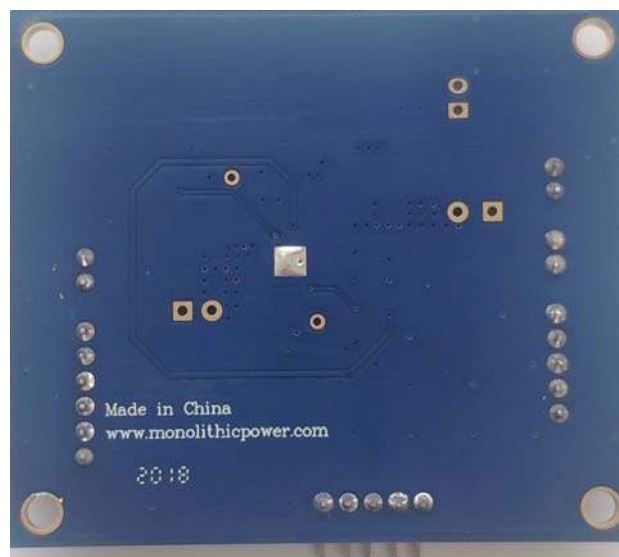

Bottom

(LxW) 6.35cmx5.25cm

Board Number	MPS IC Number
EVQ3369-R-01A	MPQ3369GR

QUICK START GUIDE

1. Provide a voltage source (3.5V to 36V) between the VIN terminal and GND on the evaluation board.
2. Connect the LED load (6 strings) terminals to:
 - a. Positive (+): LED+
 - b. Negative (-): LED1~6 pins
3. Drive the EN pin high to turn the MPQ3369 on; drive the EN pin low to turn the device off.
4. Add a 100Hz to 20kHz PWM pulse to the PWM terminal.

If using the I²C to set the IC functions, follow the additional steps below:

5. Connect the SCL, SDA, and GND pins of the evaluation board to the SCL, SDA, and GND pins of the I²C kit (EVKT-USBI2C-02), respectively.
6. Write and read the registers:
 - a. Check that the I²C kit is communicating with the computer. If the message “USB is not connected” appears on the GUI, then the I²C kit cannot communicate with the computer (see Figure 1). Otherwise, communication should be functioning properly.
 - b. Click the button(s) to select the parameter(s) that are to be changed.
 - c. After setting the desired parameters, click the “WRITE ALL” button to send the data to the IC.
 - d. To check that the data has been written to the IC, click the “READ ALL” button.

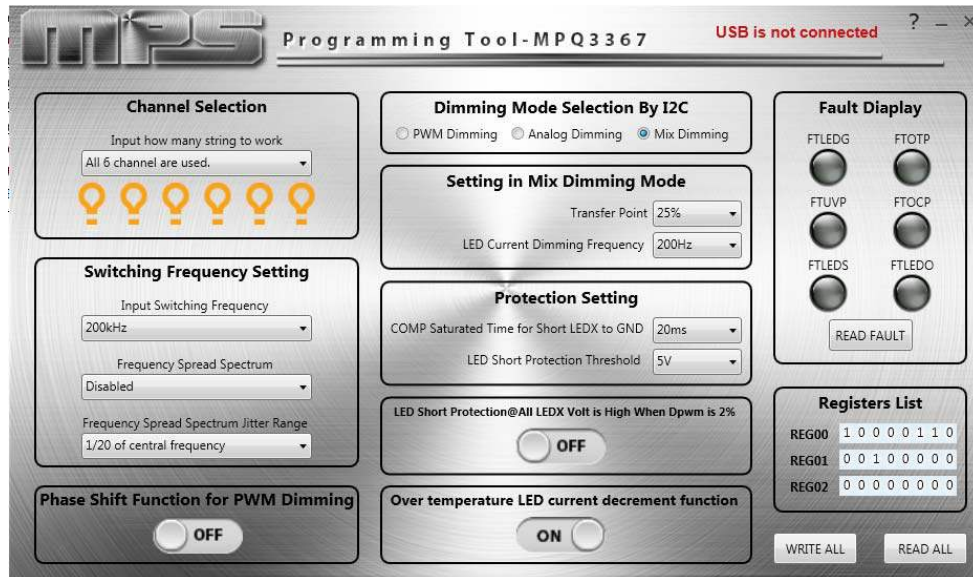

Figure 1: MPQ3369 GUI Interface

EVALUATION BOARD SCHEMATIC

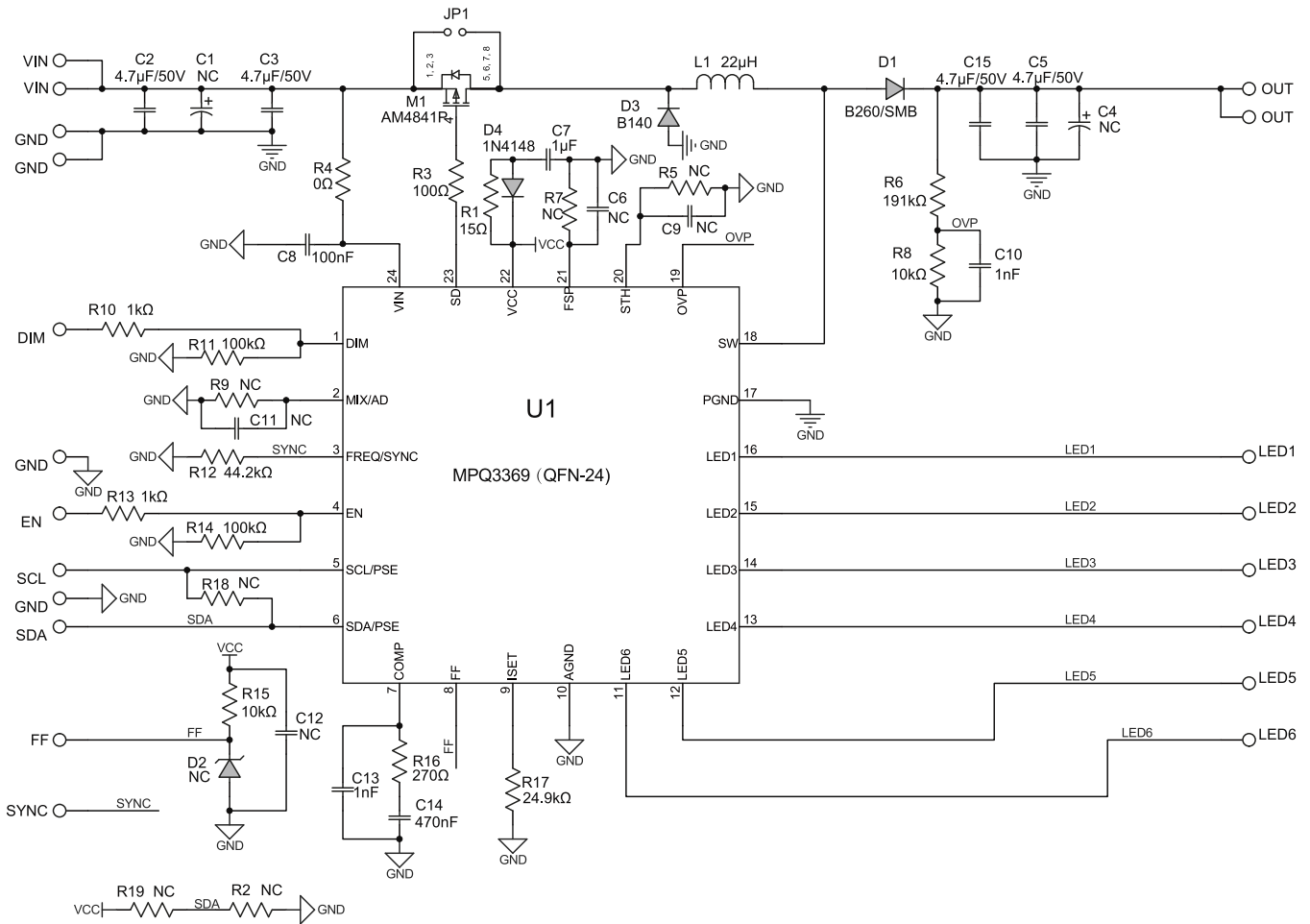

Figure 2: Evaluation Board Schematic

EVQ3369-R-01A BILL OF MATERIALS

Qty	Ref	Value	Description	Package	Manufacturer	Manufacturer PN
1	C1	NC	Electrolytic capacitor, 100μF/50V	DIP		
4	C2, C3 C5, C15	4.7μF/50V	Ceramic capacitor, 50V, X7R	1210	Murata	GRM32ER71H475KA88 L
1	C4	NC	Electrolytic capacitor, 22μF/50V	DIP		
1	C7	1μF/25V	Ceramic capacitor, 25V, X7R	0805	Murata	GRM216R61E105KA12 D
1	C8	100nF/50V	Ceramic capacitor, 50V, X7R	0603	TDK	C1608X7R1H104K
4	C6, C9, C11, C12	NC		0603		
2	C10, C13	1nF/10V	Ceramic capacitor, 16V, X7R	0603	Murata	GRM188R71102KA01D
1	C14	470nF/10V	Ceramic capacitor, 16V, X7R	0603	TDK	C1608X7R1C474K
1	D1	B260	Schottky diode, 60V, 2A	SMB	Diodes Inc.	B260
1	D2	NC	Zener diode, 3.3V	SOD-123		
1	D3	B140	Schottky diode, 40V, 1A	SMA	Diodes Inc.	B140
1	D4	1N4148W	Diode, 75V, 0.15A	SOD-123	Diodes Inc.	1N4148W
1	JP1	NC	Connector, 2.54mm 180°	CONN/DIP		
1	L1	22μH	Inductor, 22μH, 68.1mΩ, I _{SAT} = 4.2A	SMD	Murata	1274AS-H-220M=P3
1	M1	AM4841P	P-channel MOSFET, -40V/9A	MOS/SO8	Analog Power	AM4841P
1	R1	15Ω	Film resistor, 1%	RES/0603	Yageo	RC0603FR-0715RL
6	R2, R5, R7, R9, R18, R19	NC	Film resistor, 1%	RES/0603		
1	R3	100Ω	Film resistor, 1%	RES/0603	Yageo	RC0603FR-07100RL
1	R4	0Ω	Film resistor, 1%	RES/0603	Yageo	RC0603FR-070RL
1	R6	191kΩ	Film resistor, 1%	RES/0603	Yageo	RC0603FR-07191KL
2	R8, R15	10kΩ	Film resistor, 1%	RES/0603	Yageo	RC0603FR-0710KL
2	R10, R13	1kΩ	Film resistor, 1%	RES/0603	Yageo	RC0603FR-071KL
2	R11, R14	100kΩ	Film resistor, 1%	RES/0603	Yageo	RC0603FR-07100KL
1	R12	44.2kΩ	Film resistor, 1%	RES/0603	Yageo	RC0603FR-0744K2L
1	R16	270Ω	Film resistor, 1%	RES/0603	Yageo	RC0603FR-07270RL
1	R17	24.9kΩ	Film resistor, 1%	RES/0603	Yageo	RC0603FR-0724K9L
1	U1	MPQ3369	6-channel LED driver	QFN-24 (4mmx4mm)	MPS	MPQ3369GR

PCB LAYOUT

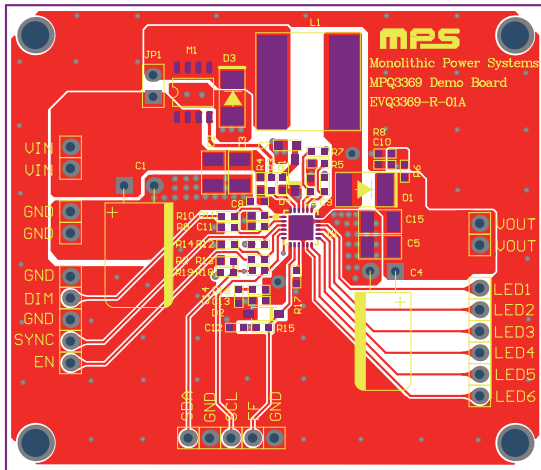

Figure 3: Top Layer

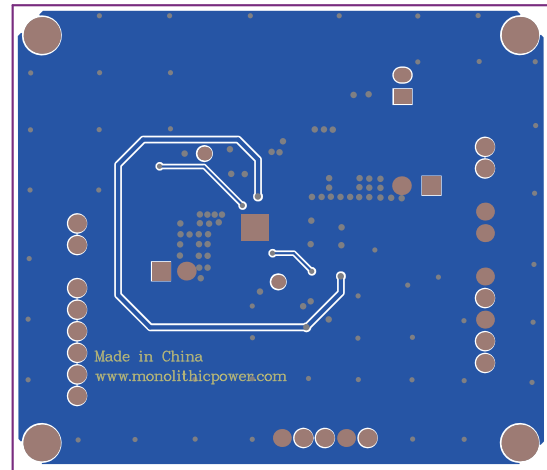

Figure 4: Bottom Layer

Revision History

Revision #	Revision Date	Description	Pages Updated
1.0	12/3/2020	Initial Release	-

Notice: The information in this document is subject to change without notice. Users should warrant and guarantee that third-party Intellectual Property rights are not infringed upon when integrating MPS products into any application. MPS will not assume any legal responsibility for any said applications.