

Improved, Ultra Low Noise $\pm 2 g$ Dual Axis Accelerometer with Ratiometric Outputs

MXR2312G/M

FEATURES

- Resolution better than 1 mg
- Dual axis accelerometer fabricated on a monolithic CMOS IC
- RoHS compliant
- On chip mixed mode signal processing
- No moving parts
- 50,000 g shock survival rating
- 17 Hz bandwidth expandable to >160 Hz
- 3.0V to 5.25V single supply continuous operation
- Continuous self test
- Independent axis programmability (special order)
- Ultra low initial Zero-g Offset

APPLICATIONS

- Automotive – Vehicle Security/Vehicle Stability control/
Headlight Angle Control/Tilt Sensing
- Security – Gas Line/Elevator/Fatigue Sensing/Computer Security
- Information Appliances – Computer Peripherals/PDA's/Cell
Phones
- Gaming – Joystick/RF Interface/Menu Selection/Tilt Sensing
- GPS – Electronic compass tilt correction
- Consumer – LCD projectors, pedometers, blood pressure
monitor, digital cameras

GENERAL DESCRIPTION

The MXR2312G/M is a low cost, dual axis accelerometer fabricated on a standard, submicron CMOS process. It is a complete sensing system with on-chip mixed mode signal processing. The MXR2312G/M measures acceleration with a full-scale range of $\pm 2 g$ and a sensitivity of 312mV/g @5V at 25°C. It can measure both dynamic acceleration (e.g. vibration) and static acceleration (e.g. gravity). The MXR2312G/M design is based on heat convection and requires no solid proof mass. This eliminates stiction and particle problems associated with competitive devices and provides shock survival of 50,000 g, leading to significantly lower failure rate and lower loss due to handling during assembly.

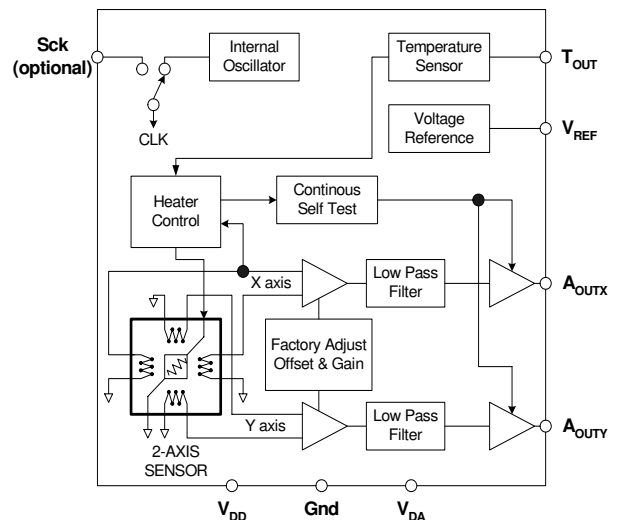

MXR2312G/M FUNCTIONAL BLOCK DIAGRAM

The MXR2312G/M provides two ratiometric analog outputs proportional to 50% of the supply voltage at zero g acceleration. The typical noise floor is $0.2 \text{ mg}/\sqrt{\text{Hz}}$ allowing signals below 1 mg to be resolved at 1 Hz bandwidth. The 3dB rolloff of the device occurs at 17 Hz but is expandable to >160 Hz (reference Application Note AN-00MX-003). The MXR2312G/M is packaged in a hermetically sealed LCC surface mount package (5 mm x 5 mm x 2 mm height) and is operational over a -40°C to 105°C(ML) and 0°C to 70°C(GL) temperature range.

Information furnished by MEMSIC is believed to be accurate and reliable. However, no responsibility is assumed by MEMSIC for its use, nor for any infringements of patents or other rights of third parties which may result from its use. No license is granted by implication or otherwise under any patent or patent rights of MEMSIC.

©MEMSIC, Inc.
One Technology Drive Suite 325, Andover MA 01810, USA
Tel: +1 978 738 0900 Fax: +1 978 738 0196
www.memsic.com

MXR2312G/M SPECIFICATIONS (Measurements @ 25°C, Acceleration = 0 g unless otherwise noted; V_{DD}, V_{DA} = 5.0V unless otherwise specified)

Parameter	Conditions	MXR2312G			MXR2312M			Units
		Min	Typ	Max	Min	Typ	Max	
SENSOR INPUT	Each Axis							
Measurement Range ¹		±2.0			±2.0			g
Nonlinearity	Best fit straight line		0.5	1.0		0.5	1.0	% of FS
Alignment Error ²	X Sensor to Y Sensor		±1.0			±1.0		degrees
Transverse Sensitivity ³			±2.0			±2.0		%
SENSITIVITY	Each Axis							
Sensitivity, Analog Outputs at pins		296	312	328	296	312	328	mV/g
A _{OUTX} and A _{OUTY} ⁵ Change over Temperature		-10		+8	-25		+8	%
ZERO g BIAS LEVEL	Each Axis							
0 g Offset ⁵		-0.1	0.0	+0.1	-0.1	0.0	+0.1	g
0 g Voltage ⁵		2.47	2.50	2.53	2.47	2.50	2.53	V
0 g Offset over Temperature	Based on 312 mV/g		±1.5			±1.5		mg/°C
			±0.47			±0.47		mV/°C
NOISE PERFORMANCE								
Noise Density, rms	Without frequency compensation		0.2	0.4		0.2	0.4	mg/√Hz
FREQUENCY RESPONSE								
3dB Bandwidth - uncompensated		15	17	19	15	17	19	Hz
3dB Bandwidth – compensated ⁴			>160			>160		Hz
TEMPERATURE OUTPUT								
T _{out} Voltage		1.15	1.25	1.35	1.15	1.25	1.35	V
Sensitivity		4.6	5.0	5.4	4.6	5.0	5.4	mV/°K
VOLTAGE REFERENCE OUTPUT								
V _{Ref} output	@3.0V-5.25V supply	2.4	2.5	2.65	2.4	2.5	2.65	V
Change over Temperature			0.1			0.1		mV/°C
Current Drive Capability	Source			100			100	µA
SELF TEST								
Continuous Voltage at A _{OUTX} , A _{OUTY} under Failure	@5.0V Supply, output rails to supply voltage		5.0			5.0		V
Continuous Voltage at A _{OUTX} , A _{OUTY} under Failure	@3.0V Supply, output rails to supply voltage		3.0			3.0		V
A _{OUTX} and A _{OUTY} OUTPUTS								
Normal Output Range	@5.0V Supply	1.0		4.0	1.0		4.0	V
Current	Source or sink, @ 3.0V-5.25V supply			100			100	µA
Turn-On Time	@5.0V Supply		160			160		mS
	@3.0V Supply		300			300		mS
POWER SUPPLY								
Operating Voltage Range		3.0		5.25	3.0		5.25	V
Supply Current	@ 5.0V	2.7	3.3	4.1	2.7	3.3	4.1	mA
Supply Current	@ 3.0V	3.2	4.0	4.8	3.2	4.0	4.8	mA
TEMPERATURE RANGE								
Operating Range		0		+70	-40		+105	°C

NOTES

¹ Guaranteed by measurement of initial offset and sensitivity.

² Alignment error is specified as the angle between the true and indicated axis of sensitivity.

³ Transverse sensitivity is the algebraic sum of the alignment and the inherent sensitivity errors.

⁴ External circuitry is required to extend the 3dB bandwidth (ref. Application Note: AN-00MX-003)

⁵ The device operates over a 3.0V to 5.25V supply range. Please note that sensitivity and zero g bias level will be slightly different at 3.0V operation. For devices to be operated at 3.0V in production, they can be trimmed at the factory specifically for this lower supply voltage operation, in which case the sensitivity and zero g bias level specifications on this page will be met. Please contact the factory for specially trimmed devices for low supply voltage operation.

ABSOLUTE MAXIMUM RATINGS*

Supply Voltage (V_{DD}, V_{DA})-0.5 to +7.0V
 Storage Temperature-65°C to +150°C
 Acceleration50,000 g

*Stresses above those listed under Absolute Maximum Ratings may cause permanent damage to the device. This is a stress rating only; the functional operation of the device at these or any other conditions above those indicated in the operational sections of this specification is not implied. Exposure to absolute maximum rating conditions for extended periods may affect device reliability.

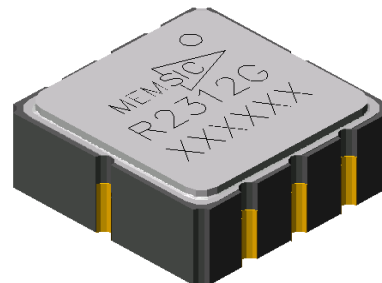

Package Characteristics

Package	θ _{JA}	θ _{JC}	Device Weight
LCC-8	110°C/W	22°C/W	< 1 gram

Pin Description: LCC-8 Package

Pin	Name	Description	I/O
1	T _{OUT}	Temperature (Analog Voltage)	O
2	A _{OUTY}	Y-Axis Acceleration Signal	O
3	Gnd	Ground	I
4	V _{DA}	Analog Supply Voltage	I
5	A _{OUTX}	X-Axis Acceleration Signal	O
6	V _{ref}	2.5V Reference Output	O
7	Sck	Optional External Clock	I
8	V _{DD}	Digital Supply Voltage	I

Ordering Guide

Model	Package Style	Temperature Range
MXR2312GL	LCC8, RoHS compliant	0 to 70°C
MXR2312GF	LCC8, Pb-free RoHS compliant	0 to 70°C
MXR2312ML	LCC8, RoHS compliant	-40 to 105°C
MXR2312MF	LCC8, Pb-free RoHS compliant	-40 to 105°C

All parts are shipped in tape and reel packaging.

Caution: ESD (electrostatic discharge) sensitive device.

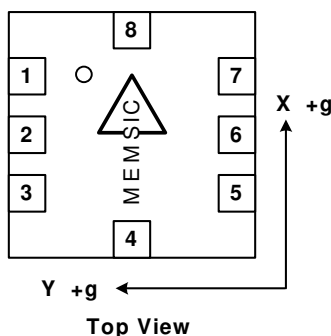

Note: The MEMSIC logo's arrow indicates the +X sensing direction of the device. The +Y sensing direction is rotated 90° away from the +X direction following the right-hand rule. Small circle indicates pin one (1).

THEORY OF OPERATION

The MEMSIC device is a complete dual-axis acceleration measurement system fabricated on a monolithic CMOS IC process. The device operation is based on heat transfer by natural convection and operates like other accelerometers having a proof mass except it is a gas in the MEMSIC sensor.

A single heat source, centered in the silicon chip is suspended across a cavity. Equally spaced aluminum/polysilicon thermopiles (groups of thermocouples) are located equidistantly on all four sides of the heat source (dual axis). Under zero acceleration, a temperature gradient is symmetrical about the heat source, so that the temperature is the same at all four thermopiles, causing them to output the same voltage.

Acceleration in any direction will disturb the temperature profile, due to free convection heat transfer, causing it to be asymmetrical. The temperature, and hence voltage output of the four thermopiles will then be different. The differential voltage at the thermopile outputs is directly proportional to the acceleration. There are two identical acceleration signal paths on the accelerometer, one to measure acceleration in the x-axis and one to measure acceleration in the y-axis. Please visit the MEMSIC website at www.memsic.com for a picture/graphic description of the free convection heat transfer principle.

MXR2312G/M PIN DESCRIPTIONS

V_{DD} – This is the supply input for the digital circuits and the sensor heater in the accelerometer. The DC voltage should be between 3.0 and 5.25 volts. Refer to the section on PCB layout and fabrication suggestions for guidance on external parts and connections recommended.

V_{DA} – This is the power supply input for the analog amplifiers in the accelerometer. Refer to the section on PCB layout and fabrication suggestions for guidance on external parts and connections recommended.

Gnd – This is the ground pin for the accelerometer.

A_{OUTX} – This pin is the output of the x-axis acceleration sensor. The user should ensure the load impedance is sufficiently high as to not source/sink >100µA. While the sensitivity of this axis has been programmed at the factory to be the same as the sensitivity for the y-axis, the accelerometer can be programmed for non-equal sensitivities on the x- and y-axes. Contact the factory for additional information on this feature.

A_{OUTY} – This pin is the output of the y-axis acceleration sensor. The user should ensure the load impedance is sufficiently high as to not source/sink >100µA. While the sensitivity of this axis has been programmed at the factory to be the same as the sensitivity for the x-axis, the accelerometer can be programmed for non-equal sensitivities on the x- and y-axes. Contact the factory for additional information on this feature.

T_{OUT} – This pin is the buffered output of the temperature sensor. The analog voltage at T_{OUT} is an indication of the die temperature. This voltage is useful as a differential measurement of temperature from ambient and not as an absolute measurement of temperature

Sck – The standard product is delivered with an internal clock option (800kHz). **This pin should be grounded when operating with the internal clock.** An external clock option can be special ordered from the factory allowing the user to input a clock signal between 400kHz and 1.6MHz.

V_{ref} – This pin is the output of a reference voltage. It is set at 2.50V typical and has 100µA of drive capability.

DISCUSSION OF TILT APPLICATIONS AND RESOLUTION

Tilt Applications: One of the most popular applications of the MEMSIC accelerometer product line is in tilt/inclination measurement. An accelerometer uses the force of gravity as an input to determine the inclination angle of an object.

A MEMSIC accelerometer is most sensitive to changes in position, or tilt, when the accelerometer’s sensitive axis is perpendicular to the force of gravity, or parallel to the Earth’s surface. Similarly, when the accelerometer’s axis is parallel to the force of gravity (perpendicular to the Earth’s surface), it is least sensitive to changes in tilt.

Table 1 and Figure 2 help illustrate the output changes in the X- and Y-axes as the unit is tilted from +90° to 0°. Notice that when one axis has a small change in output per degree of tilt (in mg), the second axis has a large change in output per degree of tilt. The complementary nature of these two signals permits low cost accurate tilt sensing to be achieved with the MEMSIC device (reference application note AN-00MX-007).

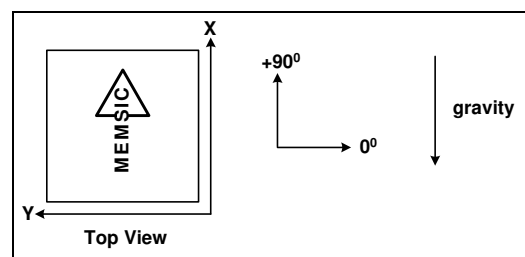

Figure 2: Accelerometer Position Relative to Gravity

X-Axis Orientation To Earth’s Surface (deg.)	X-Axis		Y-Axis	
	X Output (g)	Change per deg. of tilt (mg)	Y Output (g)	Change per deg. of tilt (mg)
90	1.000	0.15	0.000	17.45
85	0.996	1.37	0.087	17.37
80	0.985	2.88	0.174	17.16
70	0.940	5.86	0.342	16.35
60	0.866	8.59	0.500	15.04
45	0.707	12.23	0.707	12.23
30	0.500	15.04	0.866	8.59
20	0.342	16.35	0.940	5.86
10	0.174	17.16	0.985	2.88
5	0.087	17.37	0.996	1.37
0	0.000	17.45	1.000	0.15

Table 1: Changes in Tilt for X- and Y-Axes

Resolution: The accelerometer resolution is limited by noise. The output noise will vary with the measurement bandwidth. With the reduction of the bandwidth, by applying an external low pass filter, the output noise drops. Reduction of bandwidth will improve the signal to noise ratio and the resolution. The output noise scales directly with the square root of the measurement bandwidth. The maximum amplitude of the noise, its peak- to- peak value, approximately defines the worst case resolution of the measurement. With a simple RC low pass filter, the rms noise is calculated as follows:

$$\text{Noise (mg rms)} = \text{Noise(mg}/\sqrt{\text{Hz}}) * \sqrt{(\text{Bandwidth(Hz)} * 1.6)}$$

The peak-to-peak noise is approximately equal to 6.6 times the rms value (for an average uncertainty of 0.1%).

EXTERNAL FILTERS

AC Coupling: For applications where only dynamic accelerations (vibration) are to be measured, it is recommended to ac couple the accelerometer output as shown in Figure 3. The advantage of ac coupling is that variations from part to part of zero *g* offset and zero *g* offset versus temperature can be eliminated. Figure 3 is a HPF (high pass filter) with a -3dB breakpoint given by the equation: $f = \frac{1}{2\pi RC}$. In many applications it may be

desirable to have the HPF -3dB point at a very low frequency in order to detect very low frequency accelerations. Sometimes the implementation of this HPF may result in unreasonably large capacitors, and the designer must turn to digital implementations of HPFs where very low frequency -3dB breakpoints can be achieved.

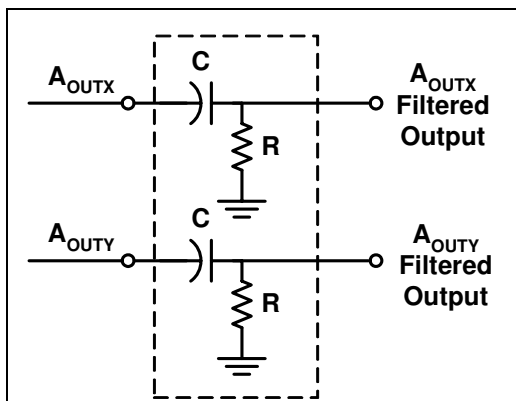

Figure 3: High Pass Filter

Low Pass Filter: An external low pass filter is useful in low frequency applications such as tilt or inclination. The low pass filter limits the noise floor and improves the resolution of the accelerometer. **When designing with MEMSIC ratiometric output accelerometers (MXRxxxx series), it is highly recommended that an external, 20 Hz low pass filter be used to eliminate internally generated periodic noise that is coupled to the output of the accelerometer.** The low pass filter shown in Figure 4 has a -3dB breakpoint given by the equation: $f = \frac{1}{2\pi RC}$. For the 200 Hz ratiometric output device filter, C=0.2µF and R=39kΩ, ±5%, 1/8W.

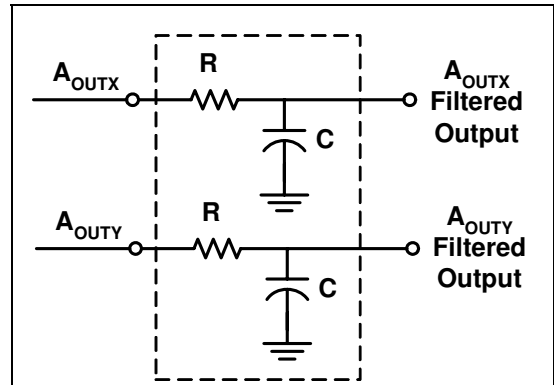

Figure 4: Low Pass Filter

POWER SUPPLY NOISE REJECTION

Two capacitors and a resistor are recommended for best rejection of power supply noise (reference Figure 5 below). The capacitors should be located as close as possible to the device supply pins (V_{DA}, V_{DD}). The capacitor lead length should be as short as possible, and surface mount capacitors are preferred. For typical applications, capacitors C1 and C2 can be ceramic 0.1 µF, and the resistor R can be 10 Ω.

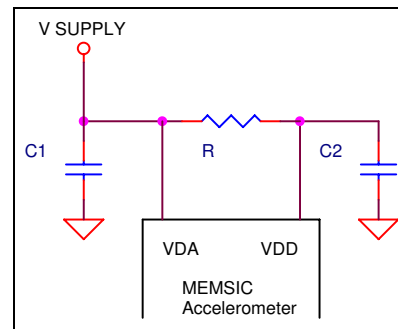

Figure 5: Power Supply Noise Rejection

PCB LAYOUT AND FABRICATION SUGGESTIONS

1. The Sck pin should be grounded to minimize noise.
2. Liberal use of ceramic bypass capacitors is recommended.
3. Robust low inductance ground wiring should be used.
4. Care should be taken to ensure there is “thermal symmetry” on the PCB immediately surrounding the MEMSIC device and that there is no significant heat source nearby.
5. A metal ground plane should be added directly beneath the MEMSIC device. The size of the plane should be similar to the MEMSIC device’s footprint and be as thick as possible.
6. Vias can be added symmetrically around the ground plane. Vias increase thermal isolation of the device from the rest of the PCB.

PACKAGE DRAWING

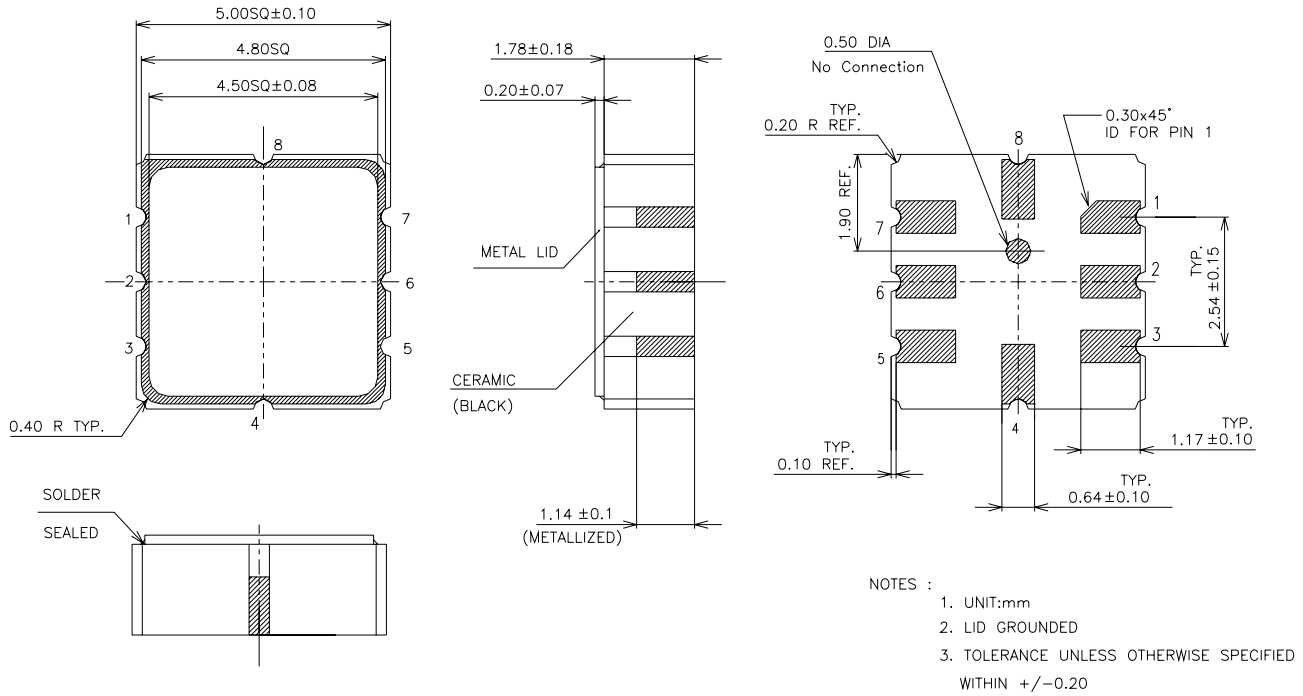

Figure 8: Hermetically Sealed Package Outline
Preliminary