



ON Semiconductor®

<http://onsemi.com>

LV5026MC

Bi-CMOS IC

LED Driver IC

Overview

LV5026MC is a High voltage LED drive controller which drives LED current up to 3A with external MOSFET. LV5026MC is realized very simple LED circuits with a few external parts. It corresponds to various wide dimming controls including the TRIAC dimming control.

Note) This LV5026MC is designed or developed for general use or consumer appliance. Therefore, it is NOT permitted to use for automotive, communication, office equipment, industrial equipment.

Functions

- High voltage LED controller
- Various Dimming Control
 - TRIAC & Analog Input & PWM Input
- Soft Start function
- Built-in TRIAC stabilized function
- Built-in circuit of detection of overvoltage of CS pin.
- Selectable Switching frequency [50kHz or 70kHz, open: 50kHz]
- Short protection circuit
- Selectable reference Voltage
 - Internal 0.605V & External Input Voltage
- Low noise switching system/skip frequency function
 - 5 stages skip mode Frequency
 - Soft driving

Specifications

Maximum Ratings at Ta = 25°C

Parameter	Symbol	Conditions	Ratings	Unit
Maximum input voltage	V _{IN} max (Note1)		-0.3 to 42	V
REF_OUT, REF_IN, RT, CS, PWM_D, ACS			-0.3 to 7	V
OUT1 pin	V _{OUT_abs}		-0.3 to 42	V
OUT2 pin	V _{OUT2_abs}		-0.3 to 42	V
Allowable power dissipation	P _d max	With specified board*	1.0	W
Junction temperature	T _j		150	°C
Operating junction temperature	T _{opj} (Note2)		-30 to +125	°C
Storage temperature	T _{stg}		-40 to +150	°C

*1 Specified board: 58.0mm × 54.0mm × 1.6mm (glass epoxy board)

Note1) Absolute maximum ratings represent the values which cannot be exceeded for any length of time.

Note2) Even when the device is used within the range of absolute maximum ratings, as a result of continuous usage under high temperature, high current, high voltage, or drastic temperature change, the reliability of the IC may be degraded. Please contact us for the further details.

Stresses exceeding Maximum Ratings may damage the device. Maximum Ratings are stress ratings only. Functional operation above the Recommended Operating Conditions is not implied. Extended exposure to stresses above the Recommended Operating Conditions may affect device reliability.

LV5026MC

Recommended Operating Conditions at Ta = 25°C

Parameter	Symbol	Conditions	Ratings	Unit
Input voltage	V _{IN}		8.5 to 24	V

* Note : supply the stabilized voltage.

Electrical Characteristics at Ta = 25°C, V_{IN} = 12V, unless otherwise specified.

Parameter	Symbol	Conditions	Ratings			Unit
			min	typ	max	
Reference voltage block						
Built-in reference voltage	VREF		0.585	0.605	0.625	V
VREF V _{IN} line regulation	VREF_LN	V _{IN} = 8.5 to 24V		±0.5		%
Reference output voltage	REFOUT	I _{REFOUT} = 0.5mA		3.0		V
- Maximum load	REFOUT_MAX		0.5			mA
- equivalent output impedance	REFOUT_RO			10		Ω
Under voltage lockout						
Operation start Input voltage	UVLOON		8	9	10	V
Operation stop input voltage	UVLOOFF		6.3	7.3	8.3	V
Hysteresis voltage	UVLOH			1.7		V
Oscillation						
Frequency	FOSC1	RT = OPEN	40	50	60	kHz
	FOSC2	RT = REF_OUT	55	70	85	kHz
FOSC1 Switch voltage	VOSC1		2		5	V
FOSC2 Switch voltage	VOSC2				0.5	V
Maximum ON duty	MAXDuty			93		%
Comparator						
Input offset voltage (Between CS and VREF)	V _{IO_VR}			1	10	mV
Input offset voltage (Between CS and REF _{IN})	V _{IO_RI}			1	10	mV
Input current	I _{IOSC}			160		nA
	I _{IOREF}			80		nA
CS pin max voltage	VOM				1	V
malfunction prevention mask time	TMSK			150		ns
PWM_D circuit						
OFF voltage	V _{OFF}		2		5	V
ON voltage	V _{ON}		0		0.6	V
Thermal protection circuit						
Thermal shutdown temperature	TSD	*Design guarantee		165		°C
Thermal shutdown hysteresis	ΔTSD	*Design guarantee		30		°C
Drive Circuit						
OUT sink current	I _{OI}		500	1000		mA
OUT source current	I _{OO}			120		mA
Minimum On time	TMIN			200	300	ns

Continued on next page.

LV5026MC

Continued from preceding page.

Parameter	Symbol	Conditions	Ratings			Unit
			min	typ	max	
TRIAC Stabilization circuit						
Threshold of OUT2	V_{ACS}	OUT2 = High [less than right record]	2.8	3.0	3.2	V
OUT2 sink current	I_{O2I}	$V_{IN} = 12V, OUT2 = 6V$		0.6		mA
OUT2 source current	I_{O2O}	$V_{IN} = 12V, OUT2 = 6V$		0.6		mA
V_{CC} current						
UVLO mode V_{IN} current	I_{CCOFF}	$V_{IN} < UVLOON$		80	120	μA
Normal mode V_{IN} current	I_{CCON}	$V_{IN} > UVLOON, OUT = OPEN$		0.8		mA
V_{IN} over voltage protection circuit						
V_{IN} over voltage protection voltage	$V_{INOV P}$		24	27	30	V
V_{IN} current at OVP	$I_{INOV P}$	$V_{IN} = 30V$	0.7	1.0	1.5	mA
CS terminal abnormal sensing circuit						
Abnormal sensing voltage	CSOCP			1.9		V

*: Design guarantee (value guaranteed by design and not tested before shipment)

Package Dimensions

unit : mm (typ)

3426A

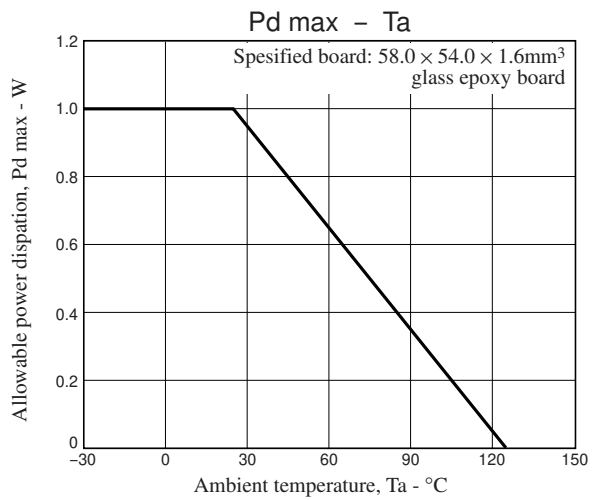
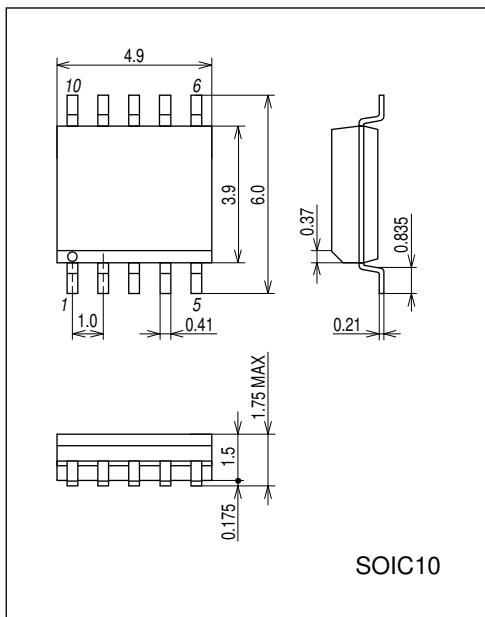

Pin Assignment

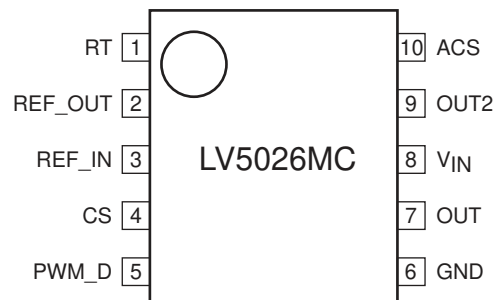

(Top view)

LV5026MC

Block Diagram

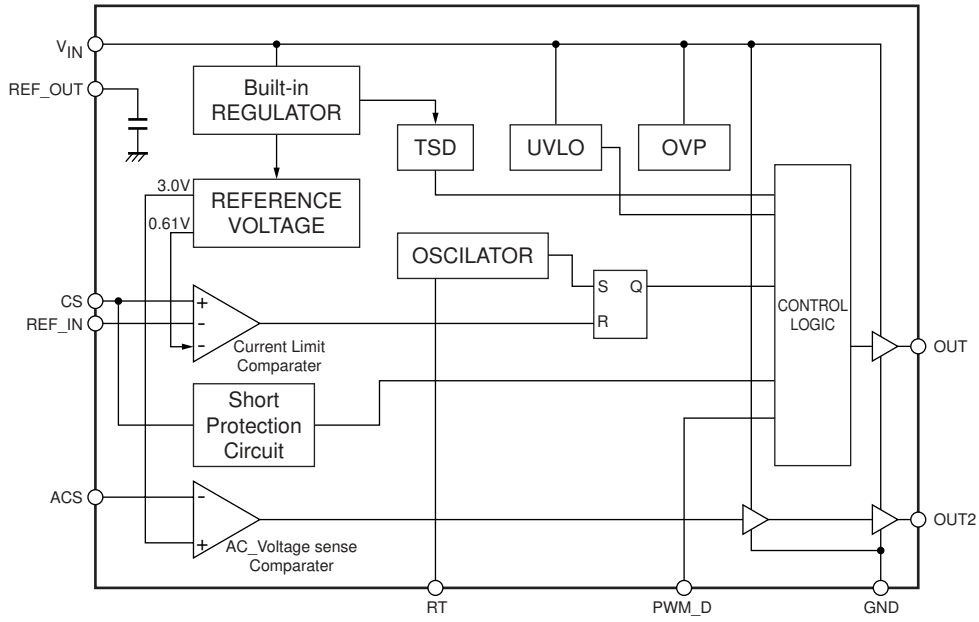

Sample Application Circuit

Non isolation

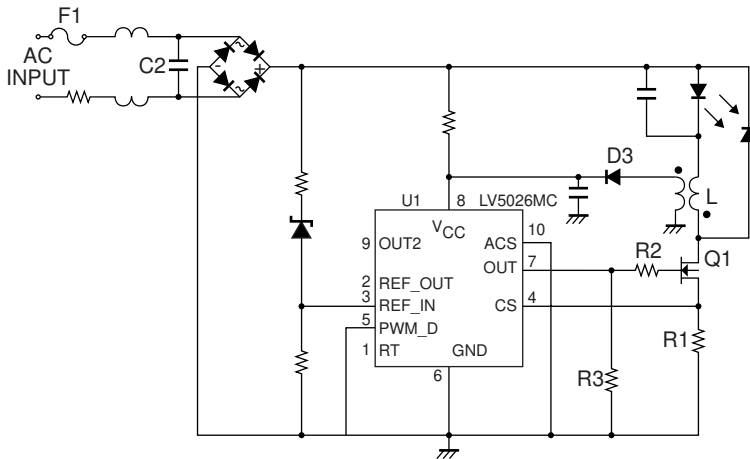

Isolation

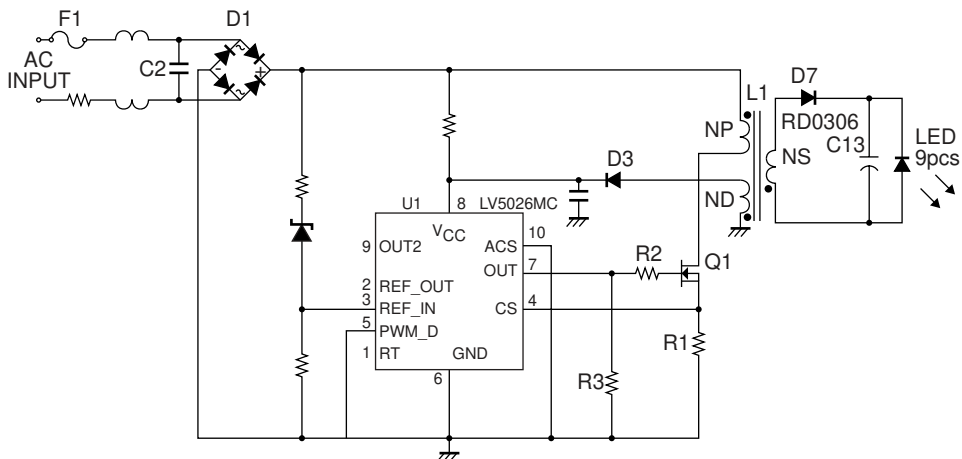

LV5026MC

Pin Functions

Pin No.	Pin name	Pin function	Equivalent circuit
1	RT	Switching frequency selection pin. L or Open : 50kHz switching, H: 70 kHz switching. In case of 70kHz,connect RT pin to REFOUT pin. on time	
2	REF_OUT	Built-in 3V Regulate out Pin. If this function isn't used, please connect to nothing.	
3	REF_IN	External LED current Limit Setting pin. If less than VREF (0.61V) voltage is input, Peak current value is used at the input voltage. If more than REF_IN voltage is input, it is done at VREF voltage. If this function isn't used, please connect nothing.	
4	CS	LED current sensing in. If this terminal voltage exceeds VREF (Or REF_IN), external FET is OFF. And if the voltage of the terminal exceeds 1.9V, LV5026MC turns to latch-off mod	
5	PWM_D	PWM Dimming pin.L or open: normal operation, H: Stop operation.	
6	GND	GND pin.	
7	OUT	Driving the external FET Gate Pin.	
8	VIN	Power supply pin. Operation : $V_{IN} > UVLOON$ Stop: $V_{IN} < UVLOOFF$ Switching Stop : $V_{IN} > V_{INOV}$	
9	OUT2	This pin drive the FET which is stabilized the TRIAC dimming application. If ACS is less than 3V, OUT2 turn High voltage. If this function isn't used, please connect nothing.	
10	ACS	ACS pin senses AC Voltage. If this function isn't used, please connect GND.	

LED current and inductance setting

• Relation ship between REF_IN and CS pin voltage(Power Factor Crrction(PFC))

The output current value is the average of the current value that flows during one cycle. The current value that flows into coil is a triangular wave shown in the figure below. Make sure to set I_{pk} so that (average of current value at one cycle) is equal to (LED current value). I_{pk} is set by the relationship between REF_IN voltage and R_{cs} voltage. This relationship make Power Factor Correction (PFC). Therefore, it is available to make LED current a sine curve.

• Setting Zener voltage

V_{zd} depend on LED voltage (V_f). Choose Zener diode around V_f (LED voltage). When VAC voltage is lower than V_f , LED operation is not normal. Using Zener diode prevents incorrect operating during VAC voltage lower than V_f . In detail, refer to [LED current and inductance setting]

In case of REF_IN pin open, this error amplifier negative input(-) is under control of internal VREF voltage (0.605V typ).

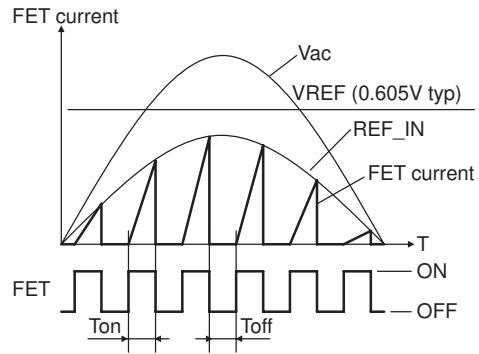
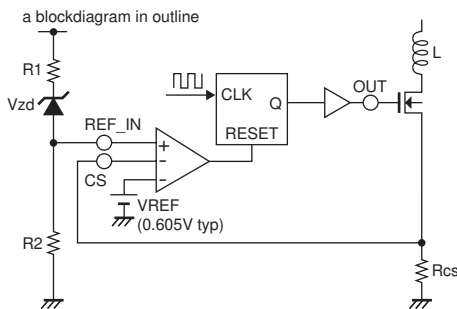

$$I_{pk} = \frac{(V_{ac} - V_{zd}) \times \frac{R_2}{R_1 + R_2}}{R_{cs}}$$

- Ipk: peak inductor current
- Vf: LED forward voltage drop
- Vac: effective value, R.M.S value
- VREF: Built-in reference voltage (0.605V)
- VREF_IN: REF_IN voltage (6 pin)
- Rs: External sense resistor
- Vzd: Zener diode voltage (REF_IN pin)

LED current and inductance setting

It is available to use both no-isolation and isolation applications.

(For non-isolation application)

The output current value is the average of the current value that flows during one cycle. The current value that flows into coil is a triangular wave shown in the figure below. Make sure to set I_{L_PK} so that (average of current value at one cycle) is equal to (LED current value).

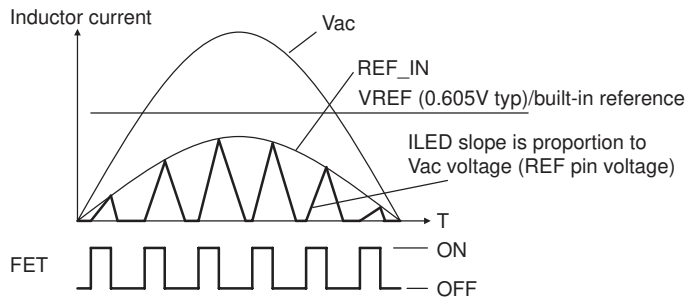
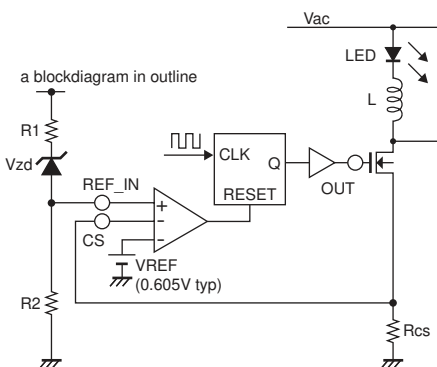

$$I_{pk} = \frac{(V_{ac} - V_f) \times L \times T_c}{V_f \times T_d}$$

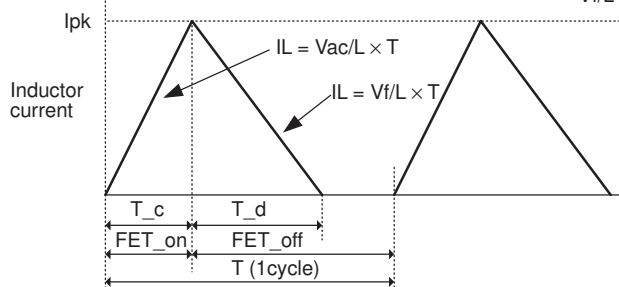

Given that the period when current flows into coil is

$$\text{DutyI} = \frac{T_{-c} + T_{-d}}{T}$$

$$I_{pk} \times \frac{1}{2} \times (\text{Duty} \times T) / T = I_{LED}$$

$$I_{pk} \times \frac{2 \times I_{LED}}{\text{DutyI}} \quad (1) \text{ since } I_{pk} \times \frac{V_{REF_IN}}{R_{cs}}$$

$$R_{cs} \times \frac{V_{FEF_IN}}{I_{pk}} = \frac{\text{DutyI} \times V_{FEF_IN}}{2I_{LED}} \quad (2)$$

I_{pk} : peak inductor current
 V_f : LED forward voltage drop
 V_{ac} : effective value(R.M.S value)
 V_{REF} : Built-in reference voltage (0.605V)
 V_{REF_IN} : REF_IN voltage (6 pin)
 R_s : External sense resistor
 V_{zd} : Zener diode voltage (REF_IN pin)

Since formula for LED current is different between on period and off period as shown above,

$$I_{pk} \times \frac{V_{ac} - V_f}{L} \times T_{-c} = \frac{V_f}{L} \times T_{-d} \quad (3)$$

$$\text{Since } T_{-c} + T_{-d} = \text{DutyI} \times T, T_{-c} = \text{DutyI} \times T - T_{-d} \quad (4)$$

$$\text{Based on the result of (3) and (4), } T_{-d} = \text{DutyI} \times T \times \frac{V_{ac} - V_f}{V_{ac}} \quad (5)$$

To obtain L from the equation (1), (3), (5),

$$L \times \frac{V_f \times \text{DutyI}}{2 \times I_{LED}} \times \text{DutyI} \times T = \frac{V_{ac} - V_f}{V_{ac}} = \frac{V_f}{2 \times I_{LED}} \times \frac{1}{f_{osc}} \times \frac{V_{ac} - V_f}{V_{ac}} \times (\text{DutyI})^2 \quad (6)$$

Since LED and inductor are connected in serial in non-isolation mode, LED current flows only when AC voltage exceed VF.

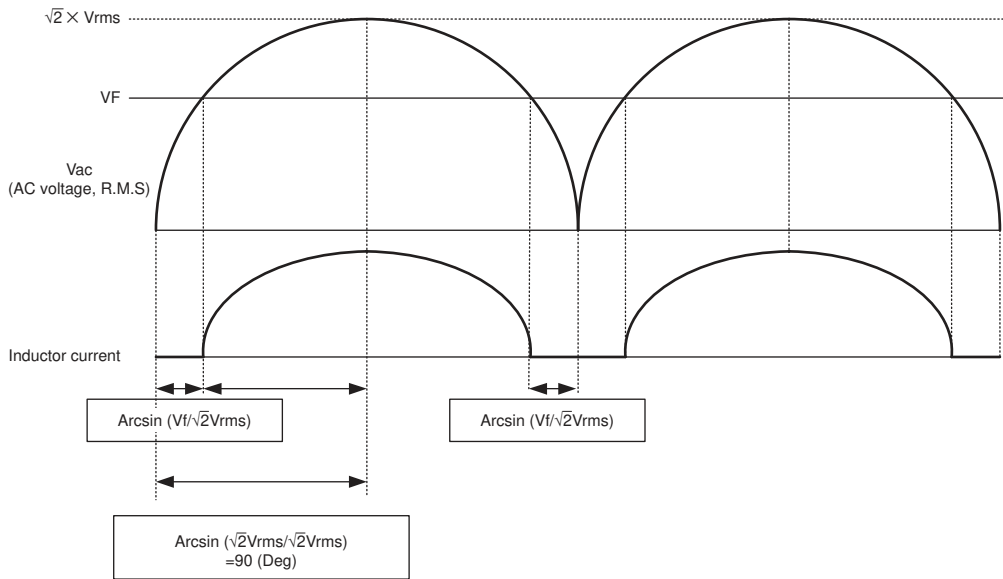

Given that the ratio of inductor current to AC input is DutyAC.

$$\text{DutyAC} = \frac{90 - \arcsin\left(\frac{V_f}{\sqrt{2}V_{rms}}\right)}{90}$$

Since the period when the inductor current flows are limited by DutyAC, the formula (6) is represented as follows:

$$L = \frac{V_f}{2 \times I_{LED}} \times \frac{1}{f_{osc}} \times \frac{V_{ac} - V_f}{V_{IN}} \times (\text{DutyI})^2 \times \left(\frac{90 - \arcsin\left(\frac{V_f}{\sqrt{2}V_{rms}}\right)}{90} \right)^2 \quad (7)$$

LV5026MC

(for Isolation circuit)

Using the circuit diagram below, the wave form of the current that flows to Np and Ns is as follows.
Current waveform flows to primary side and secondary.

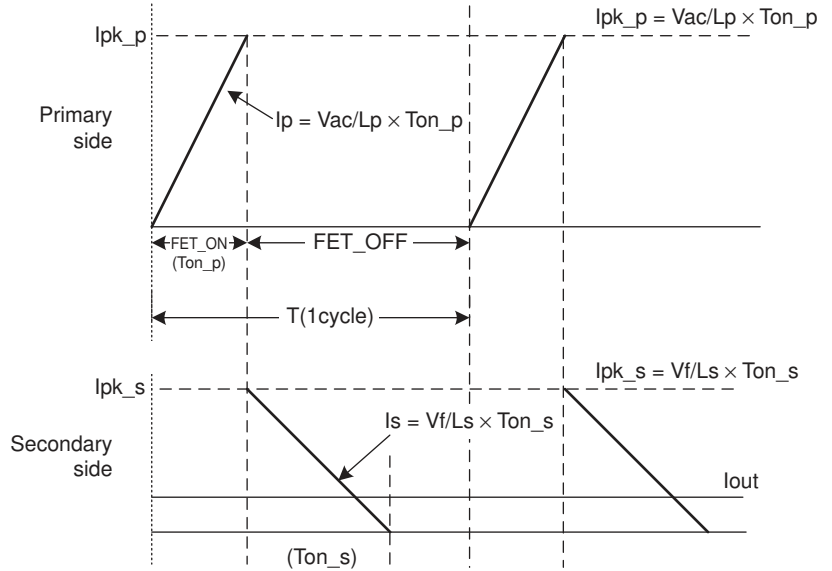
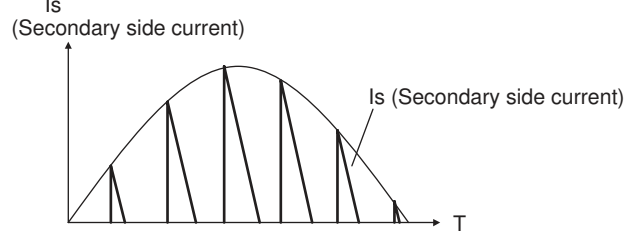
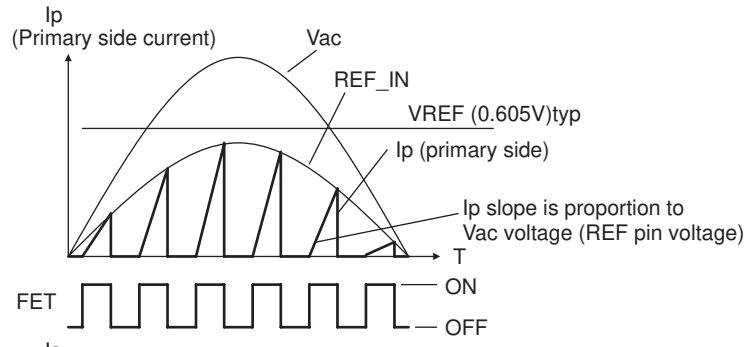
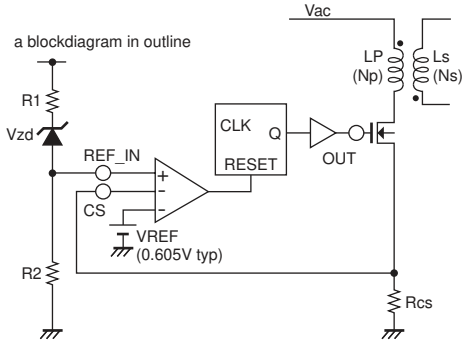

[Inductance Lp of primary side and sense resistor Rs]

If a peak current flow to transformer is represented as Ipk_p, the power (Pin) charged to the transformer on primary side can be represented as:

$$P_{in} = \frac{1}{2} \times L_p \times (I_{pk_p})^2 \times f_{osc} \quad (11)$$

$$I_{pk_p} = \frac{Vac}{L_p} \times T_{on_p} \quad (12)$$

$$L_p = \frac{Vac^2 \times T_{on_p}^2 \times f_{osc}}{2 \times P_{in}} = \frac{Vac^2 \times Don_p^2}{2 \times P_{in} \times f_{osc}} \quad (13)$$

$$(Don_p = \frac{T_{on_p}}{T} = T_{on_p} \times f_{osc}),$$

To substitute the following to the formula below,

$$\therefore \eta = \frac{P_{out}}{P_{in}} \quad (14)$$

$$\therefore L_p = \frac{Vac^2 \times T_{on_p}^2 \times f_{osc} \times \eta}{2 \times P_{out}} = \frac{Vac^2 \times Don^2 \times \eta}{2 \times P_{out} \times f_{osc}} \quad (15)$$

Sense resistor is obtained as follows.

$$R_s = \frac{V_{REF_IN}}{I_{pk_p}} = \frac{V_{REF_IN} \times L_p}{Vac \times Ton_p} = \frac{V_{REF_IN} \times L_p}{Vac \times Don_p \times T} \quad (16)$$

[Inductance L_s of secondary side]

Since output current I_{out} is the average value of current flows to transformer of secondary side

$$I_{out} = I_{pk_s} \times \frac{Ton_s}{T} \times \frac{1}{2} = \frac{I_{pk_s} \times Don_s}{2} \quad (Don_s = \frac{Ton_s}{T} = Ton_s \times f_{osc}) \quad (17)$$

$$I_{pk_s} = \frac{V_{out}}{L_s} \times Ton_s = \frac{V_{out}}{L_s} = \frac{Don_s}{f_{osc}} \quad (18)$$

$$L_s = \frac{V_{out} \times T \times Don_s^2}{2 \times I_{out}} = \frac{V_{out} \times Don_s^2}{2 \times I_{out} \times f_{osc}} = \frac{V_{out}^2 \times Don_s^2}{2 \times P_{out} \times f_{osc}} \quad (19)$$

Calculation of the ratio of transformer coil on primary side and secondary side

Since ratio and inductance of transformer coil is

$$\frac{N_s}{N_p} = \frac{\sqrt{L_s}}{\sqrt{L_p}} \quad (20)$$

substituted equations (15), (19) for (20)

$$\therefore \frac{N_p}{N_s} = \frac{Vac}{V_{out}} \times \sqrt{\eta} \times \frac{Don_p}{Don_s} \quad (21)$$

Calculation of transformer coil on primary side and secondary side

$$N = \frac{Vac \times 10^8}{2 \times \Delta B \times Ae \times f_{osc}} \quad (22)$$

ΔB : variation range of core flux density [Gauss]

Ae : core section area [cm²]

To use Al (L value at 100T),

$$N = \sqrt{\frac{L}{Al}} \times 10^2 \quad (23)$$

L: inductance [μ H]

Al: L value at 100T [uH/N²]

lg (Air gap) is obtained as follows:

$$lg = \frac{\mu_r \mu_0 N^2 Ae 10^2}{L} \quad (24)$$

μ_r : relative magnetic permeability, $\mu_r = 1$

μ_0 : vacuum magnetic permeability $\mu_0 = 4\pi \times 10^{-7}$

N: turn count [T]

Ae : core section area [m²]

L: inductance [H]

LV5026MC

Bleeder current circuit for TRIAC dimmer

1. Operating voltage setting

ACS pin voltage set operating voltage at OUT2. ACS pin threshold voltage is 3V typ.

OUT2 operating voltage is set by R1 and R2. R1 and R2 is determined below.

$$ACS = Vac \times \frac{R2}{R1+R2}$$

2. Bleeder current setting

Rd set hold current at Triac dimmer.

Bleeder current is set at Rd depending on Triac dimmer.

a blockdiagram in outline

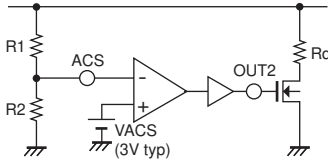

a blockdiagram in outline

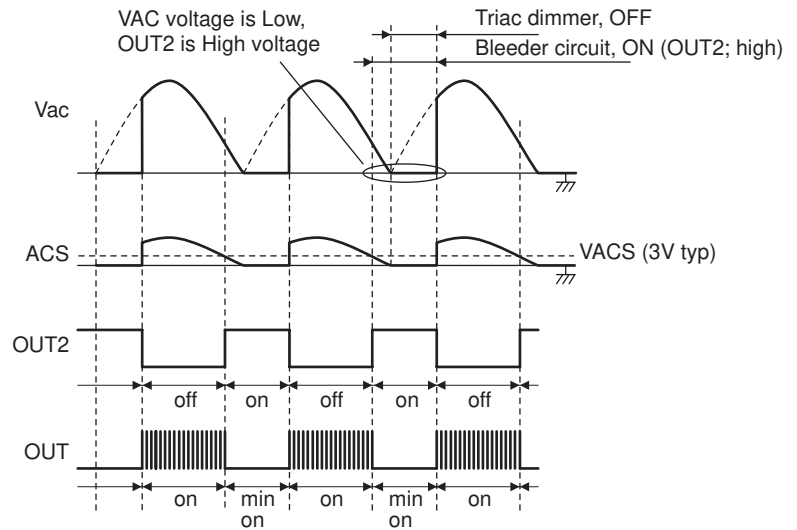

LV5026MC

Description of operation protection function

	tilte	outline	monitor point	note
1	UVLO	Under voltage lock out	V _{CC} voltage	
2	OCP	Over current protection	CS voltage	available FET current
3	OVP	Over voltage protection	V _{CC} voltage	
4	OTP (TSD)	Over Temperature Protection (Thermal Shut Down)	PN Junction temperature	

1. UVLO (Under voltage lock out)

If V_{IN} voltage is 7.3V or lower, then UVLO operates and the IC stops. When UVLO operates, the power supply current of the IC is about 80μA or lower. If V_{IN} voltage is 9V or higher, then the IC starts switching operation.

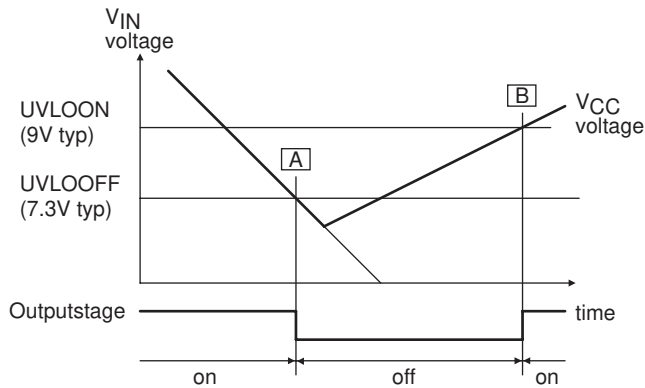

2. UVLO (Under voltage lock out)

The CS pin sense the current through the MOS FET switch and the primary side of the transformer. This provides an additional level of protection in the event of a fault. If the voltage of the CS pin exceeds VCSOCP (1.9V typ) (A), the internal comparator will detect the event and turn off the MOSFET. The peak switch current is calculated $I_o \text{ (peak) [A]} = V_{SOCP} \text{ [V]} / R_{\text{sense}} \text{ [\Omega]}$

The V_{CC} pin is pulled down to fixed level, keeping the controller latched off. The latch reset occurs when the user disconnects LED from V_{AC} and lets the V_{CC} falls below the V_{CC} reset voltage, UVLOFF (7.3V typ) (B). Then V_{CC} rise UVLOON (9V typ) (C), restart the switching.

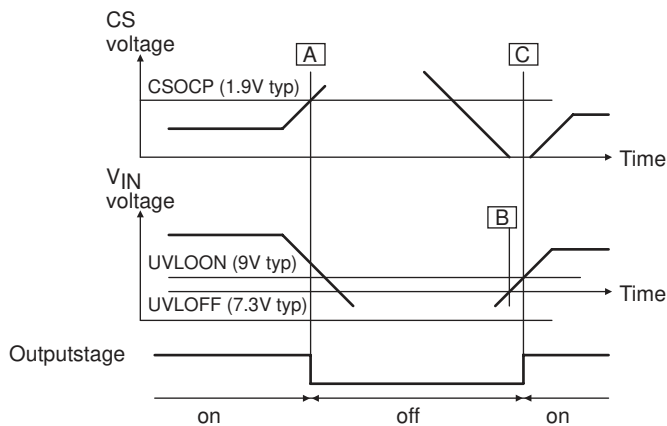

3. OVP (Over voltage protection)

If the voltage of V_{IN} pin is higher than the internal reference voltage V_{INOVLP} (27V typ), switching operation is stopped.

The stopping operation is kept until the voltage of V_{IN} is lower than 7.3V. If the voltage of V_{IN} pin is higher than 9V, the switching operation is restated.

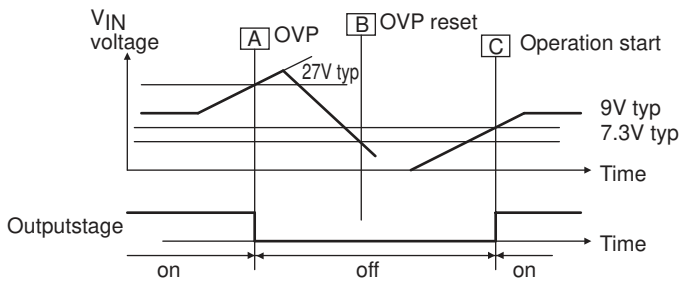

4. TSD (Thermal shut down protection)

The thermal shutdown function works when the junction temperature of IC is 165°C (typ) (A], and the IC switching stops. The IC starts switching operation again when the junction temperature is 135°C typ (B] or lower.

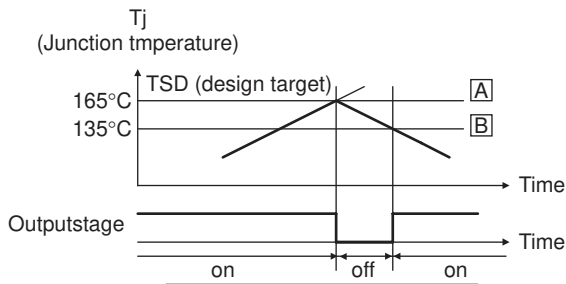

Skip frequency function

LV5026MC contains the skip frequency function for reduction of the peak value of conduction noise. This function changes the frequency as follows.

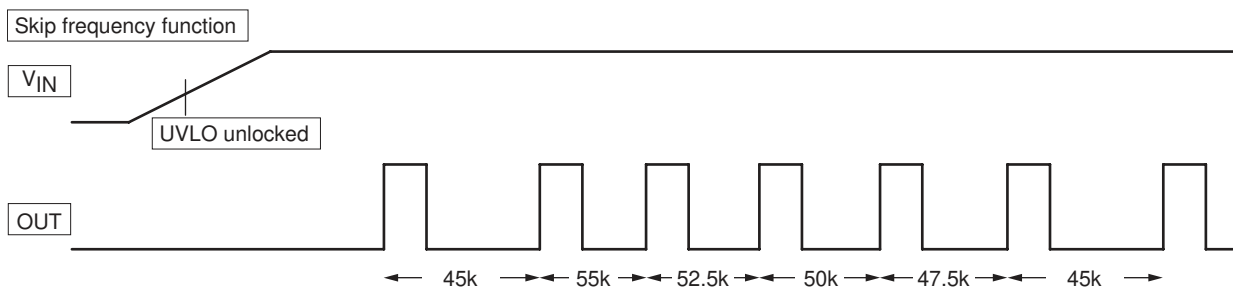

Switching frequency is changed as follows.

... $\times 0.9 \rightarrow \times 1.1 \rightarrow \times 1.05 \rightarrow \times 1 \rightarrow \times 0.95 \rightarrow \times 0.9 \rightarrow \times 1.1$...

It's repeated by this loop.

LV5026MC

PWM dimmer function

LED current can be adjusted according to Duty of PWM pulse input to PWM dimmer pin. PWM pulse is High (2V to 5V) then switching operation stops, and LED current stops flowing. PWM pulse is Low (under 0.6V), then switching operation stop is released, and it returns to normal operation.

An outline of PWM_D pin

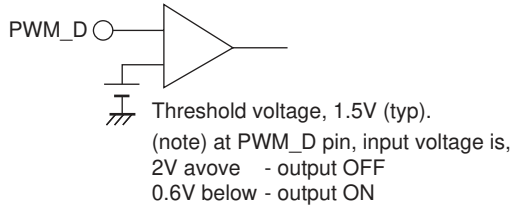

LED current vs PWM_D duty (outline)

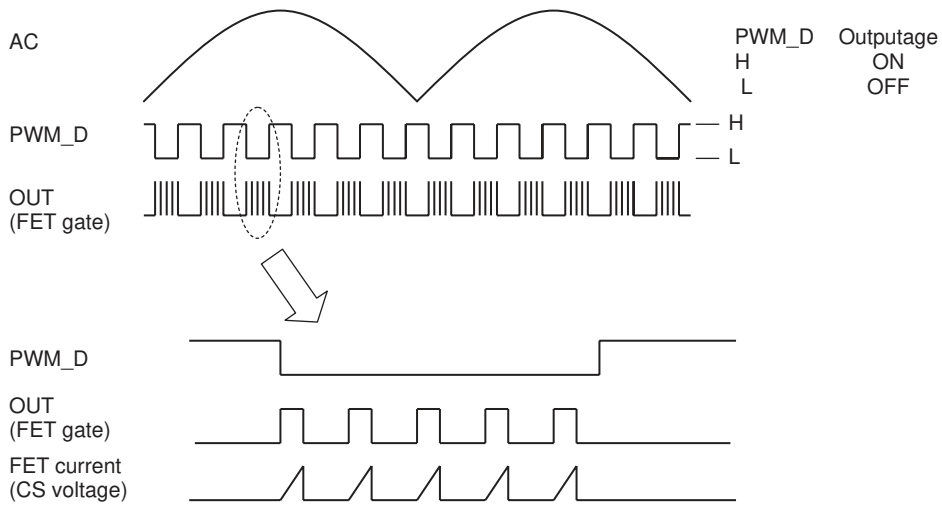
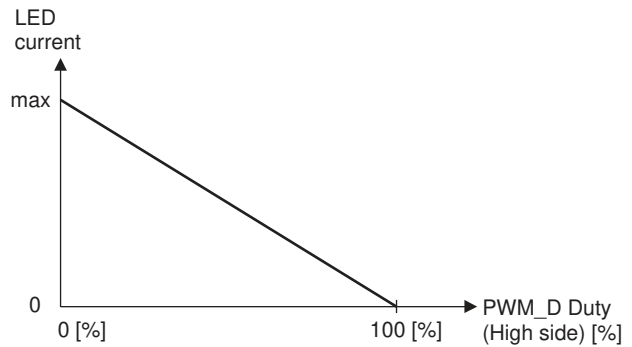

LV5026MC

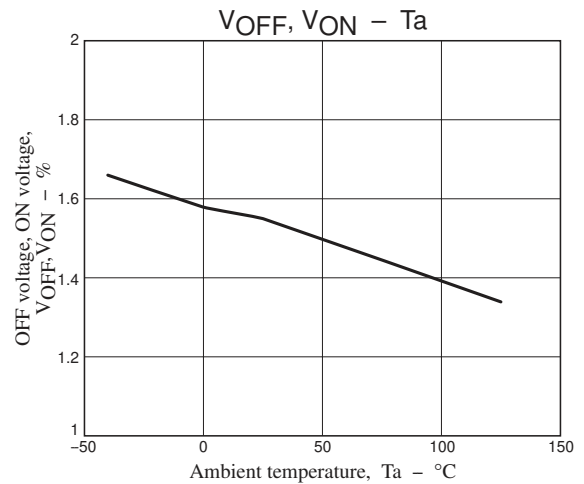
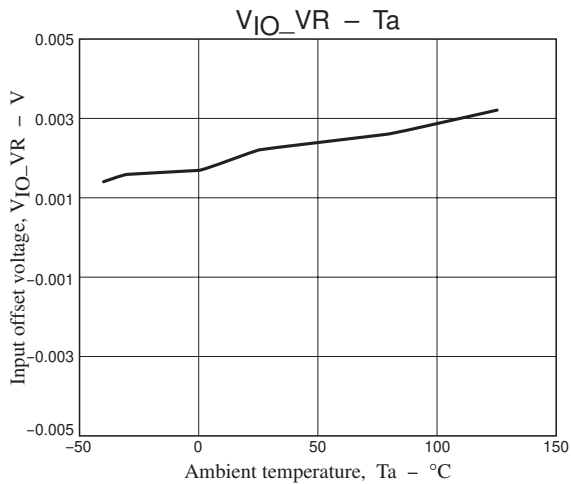
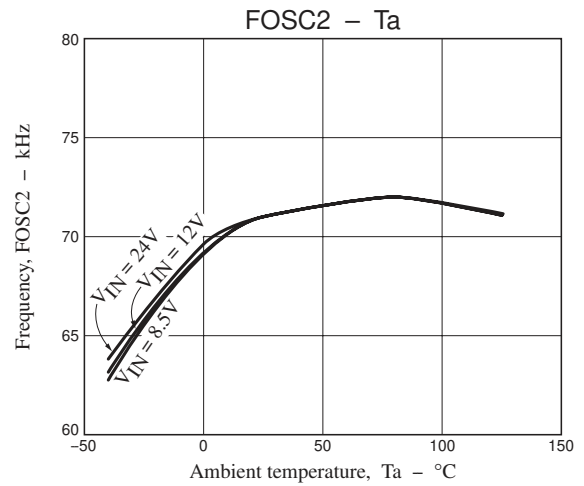
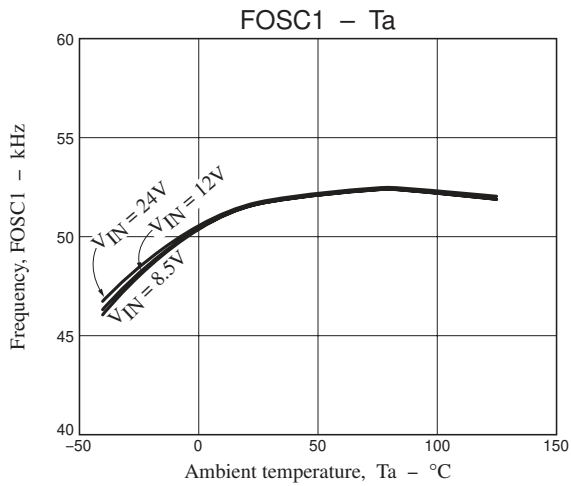
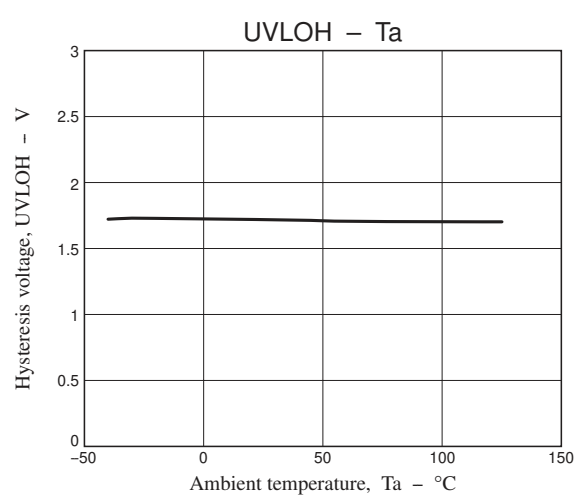
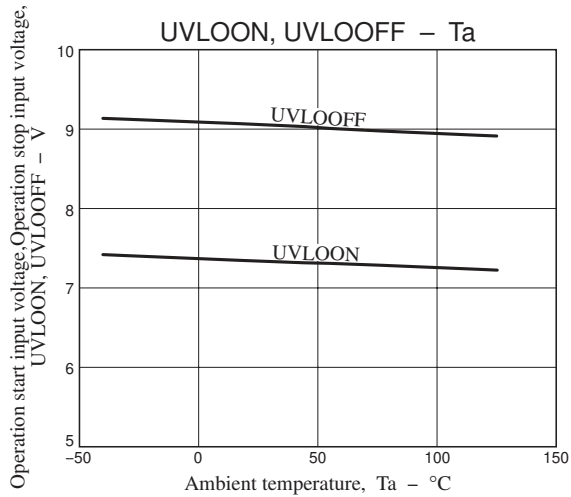
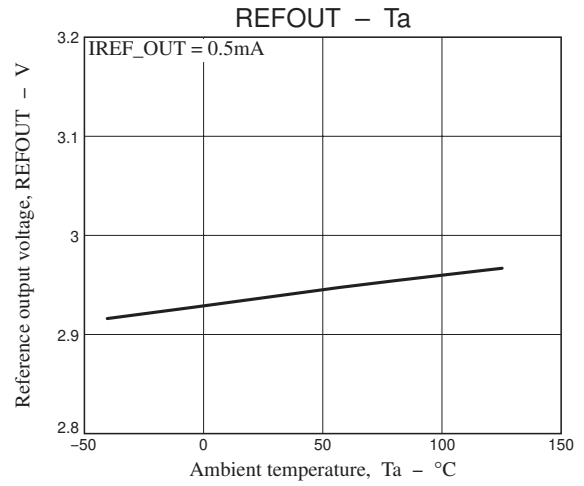
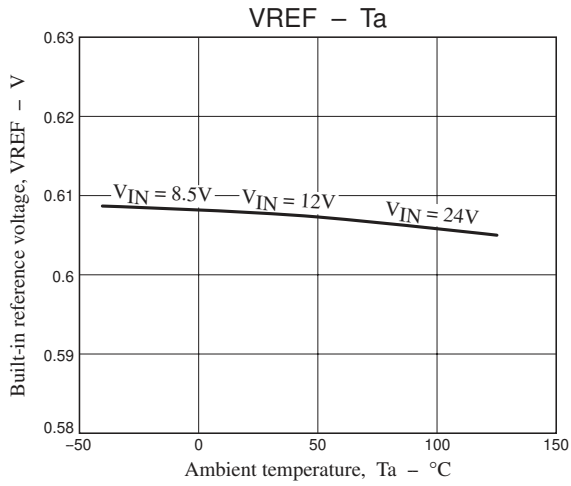

LV5026MC

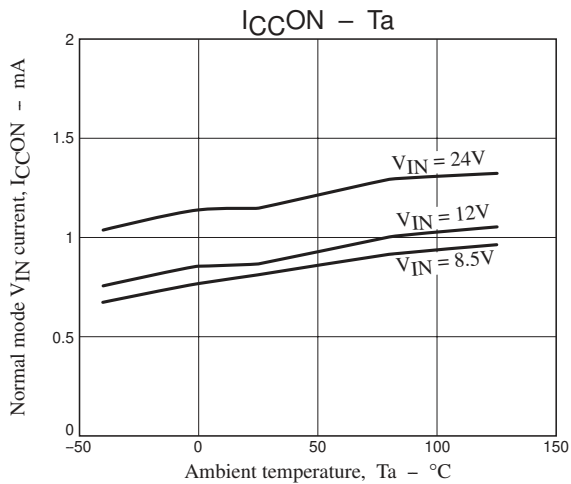
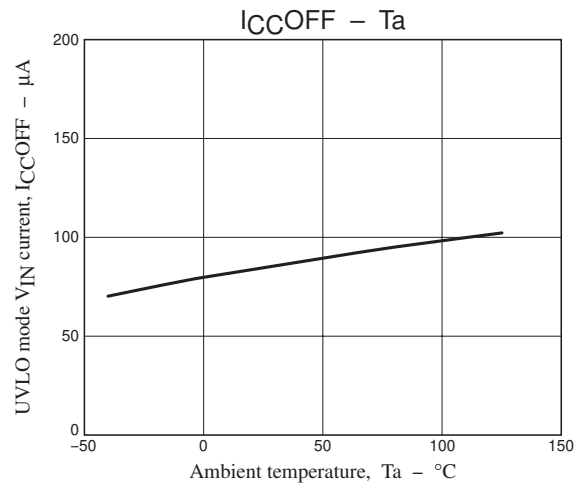
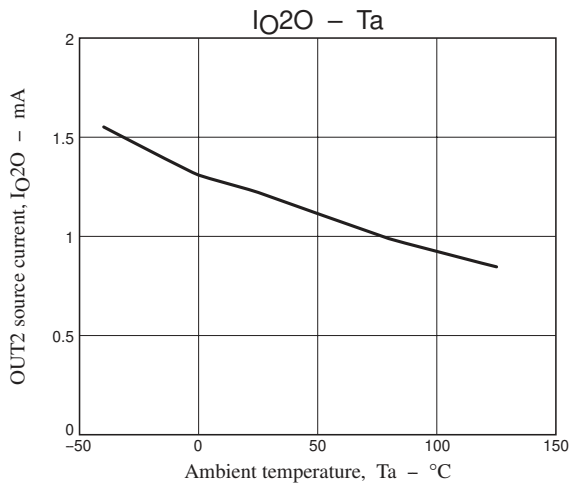
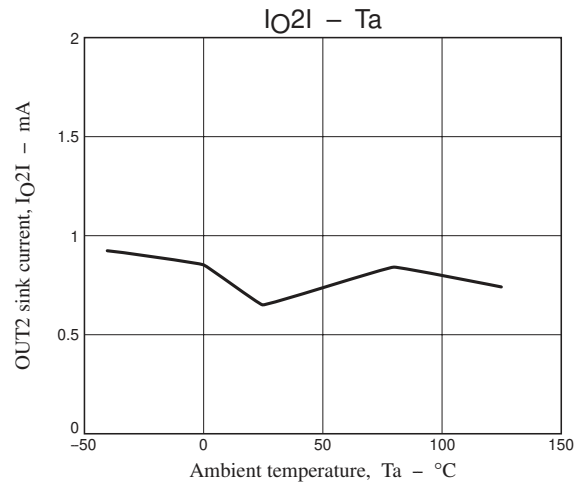
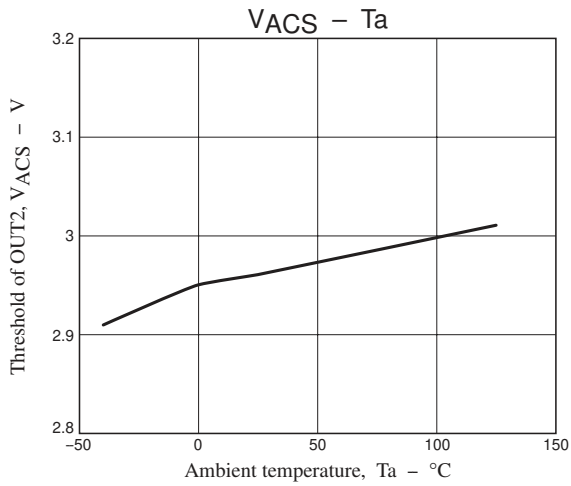
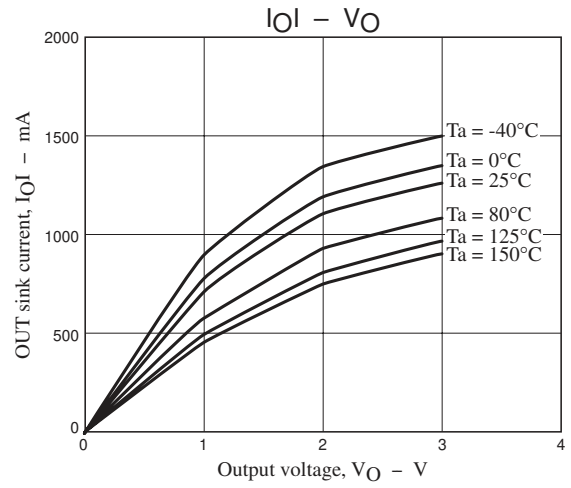
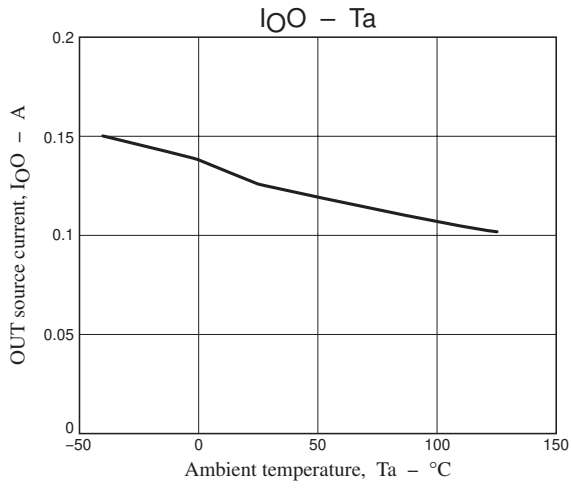

LV5026MC

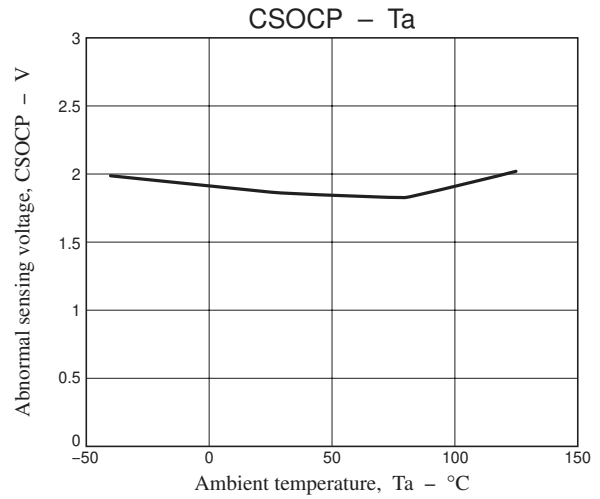
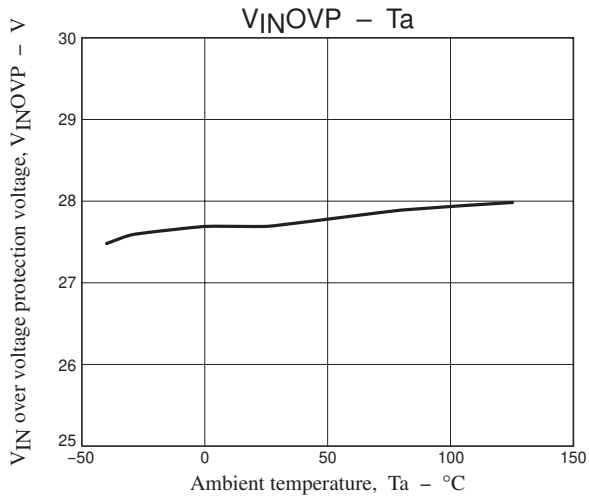

ON Semiconductor and the ON logo are registered trademarks of Semiconductor Components Industries, LLC (SCILLC). SCILLC owns the rights to a number of patents, trademarks, copyrights, trade secrets, and other intellectual property. A listing of SCILLC's product/patent coverage may be accessed at www.onsemi.com/site/pdf/Patent-Marking.pdf. SCILLC reserves the right to make changes without further notice to any products herein. SCILLC makes no warranty, representation or guarantee regarding the suitability of its products for any particular purpose, nor does SCILLC assume any liability arising out of the application or use of any product or circuit, and specifically disclaims any and all liability, including without limitation special, consequential or incidental damages. "Typical" parameters which may be provided in SCILLC data sheets and/or specifications can and do vary in different applications and actual performance may vary over time. All operating parameters, including "Typicals" must be validated for each customer application by customer's technical experts. SCILLC does not convey any license under its patent rights nor the rights of others. SCILLC products are not designed, intended, or authorized for use as components in systems intended for surgical implant into the body, or other applications intended to support or sustain life, or for any other application in which the failure of the SCILLC product could create a situation where personal injury or death may occur. Should Buyer purchase or use SCILLC products for any such unintended or unauthorized application, Buyer shall indemnify and hold SCILLC and its officers, employees, subsidiaries, affiliates, and distributors harmless against all claims, costs, damages, and expenses, and reasonable attorney fees arising out of, directly or indirectly, any claim of personal injury or death associated with such unintended or unauthorized use, even if such claim alleges that SCILLC was negligent regarding the design or manufacture of the part. SCILLC is an Equal Opportunity/Affirmative Action Employer. This literature is subject to all applicable copyright laws and is not for resale in any manner.