

LOC	DIST	REV	DATE	BY	CHK	APPD
AD	00	A2	11MAR2011	RK	HMR	

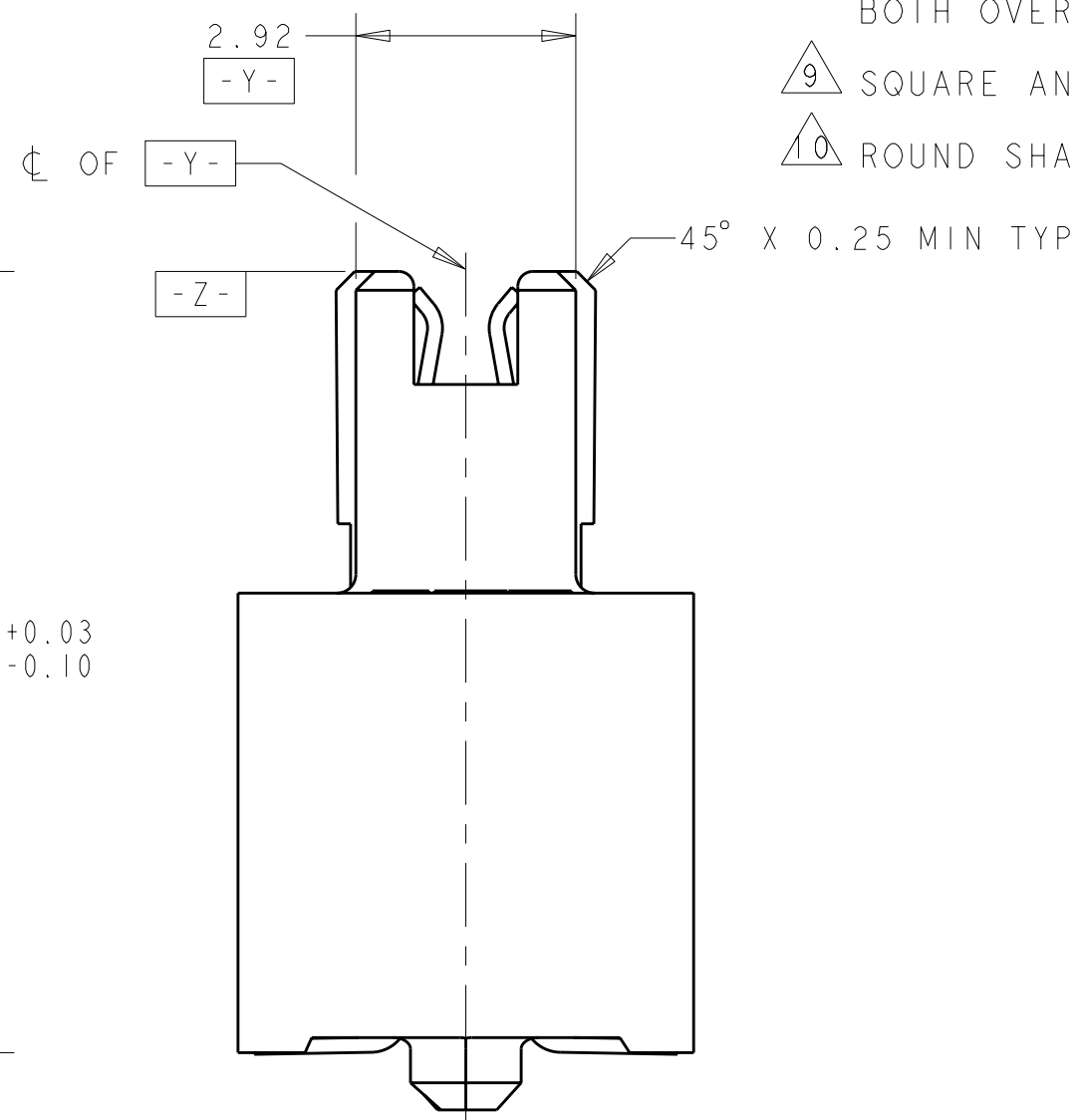

STYLE A POSTS

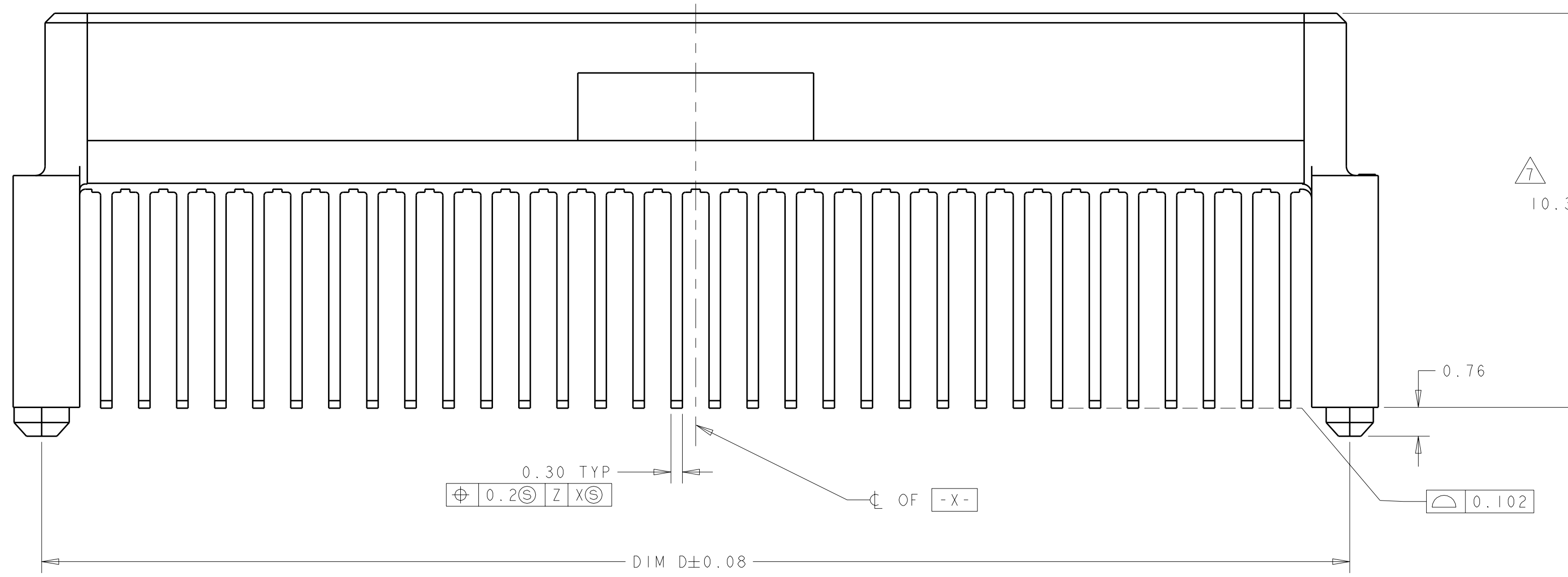
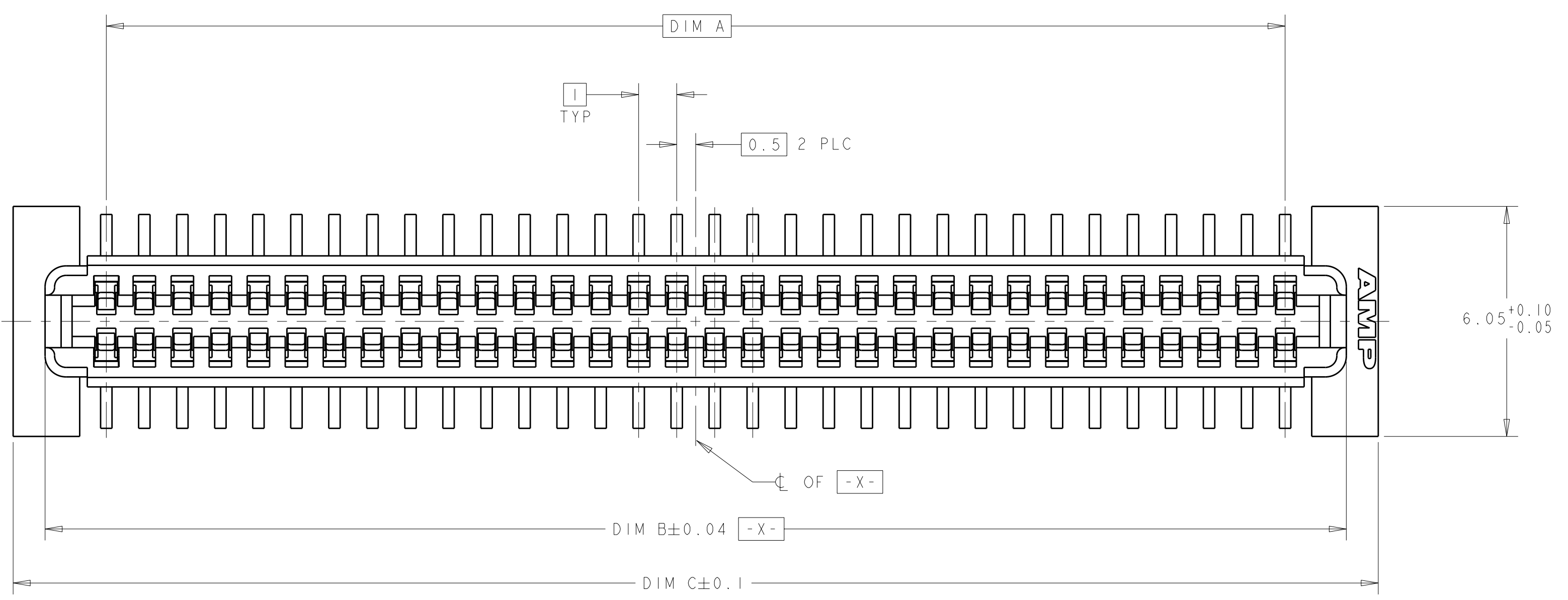
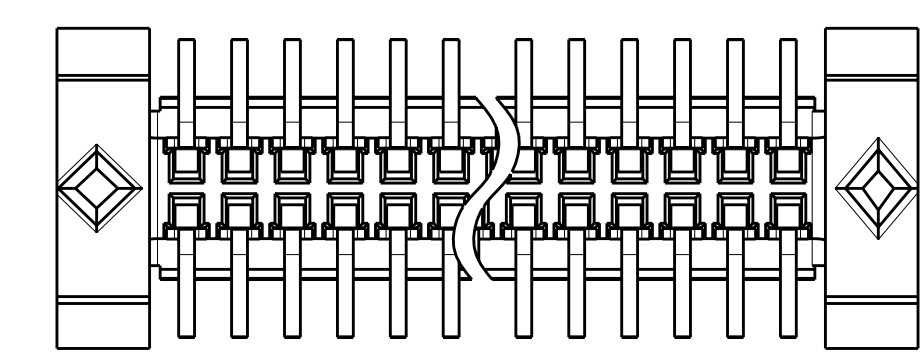

STYLE B POSTS

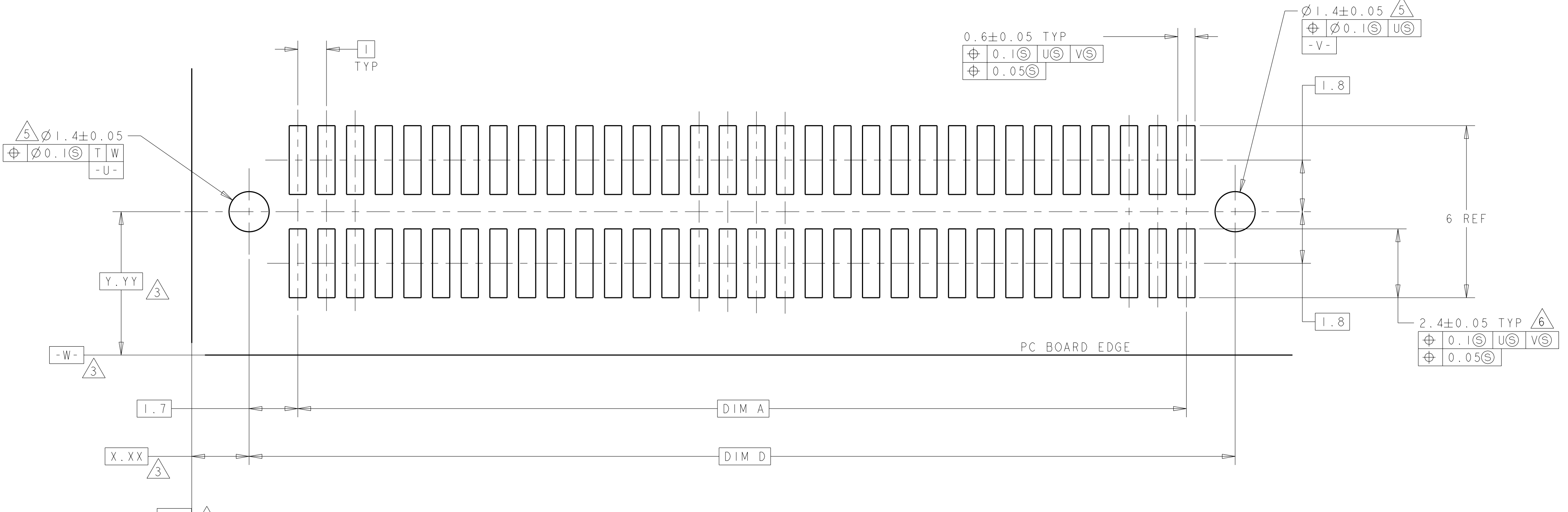
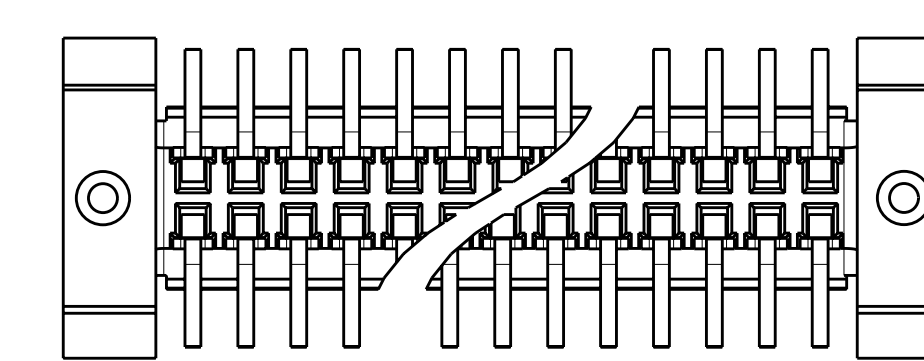

RECOMMENDED PC BOARD LAYOUT

- 1 HOUSING MATERIAL: HIGH TEMPERATURE THERMOPLASTIC, COLOR; BLACK. CONTACT MATERIAL: PHOSPHOR BRONZE.
- 2 CONTACT FINISH: NICKEL UNDERPLATE ALL OVER, MATING SURFACES PLATED TO MEET PL1 PERFORMANCE REQUIREMENTS OF INDUSTRY SPECIFICATION EIA-700AAAB. SOLDER TAILS PLATED TIN.
- 3 DATUM LOCATIONS AND BASIC DIMENSIONS TO BE ESTABLISHED BY THE CUSTOMER. CONSULT AMP ENGINEERING WHEN PLACING MULTIPLE CONNECTORS ON A PC BOARD.
- 4 PACKAGED IN TAPE ON REELS PER EIA-481.
- 5 1.5 MIN DIAMETER HOLE SHOULD BE USED IF USING POST STYLE "A" AND PLACING ON PCB WITH VACUUM PLACEMENT EQUIPMENT.
- 6 SHORTER SOLDER LANDS MAY BE USED PER EIA 700AAAB, HOWEVER 2.4 LENGTH ASSURES OPTIMUM SOLDER FILLET REGARDLESS OF MANUFACTURER OF CONNECTOR.
- 7 REFERRED TO AS DIM H = 10.3±0.1 IN EIA 700AAAB SPECIFICATION.
- 8 CONTACT FINISH: 0.00381 MINIMUM MATTE TIN PER ASTM B 545 ON SOLDER AREA, 0.00127 MINIMUM GOLD PER ASTM B 488 ON MATING AREA, BOTH OVER 0.00127 MINIMUM NICKEL PER SAE-AMS-QQ-N-290 ON ENTIRE CONTACT.
- 9 SQUARE AND DIAMOND SHAPED POSTS
- 10 ROUND SHAPED POSTS

POST STYLE	FINISH	DIM D	DIM C	DIM B	DIM A	STACK HGTS	POS	PART NO
10	8	44.4	45.9	44.22	41	14, 15	84	3-5120524-2
10	8	34.4	35.9	34.22	31	14, 15	64	3-5120524-1
10	2	44.4	45.9	44.22	41	14, 15	84	2-5120524-2
10	2	34.4	35.9	34.22	31	14, 15	64	2-5120524-1
9	8	44.4	45.9	44.22	41	14, 15	84	1-5120524-2
9	8	34.4	35.9	34.22	31	14, 15	64	1-5120524-1
9	2	44.4	45.9	44.22	41	14, 15	84	5120524-2
9	2	34.4	35.9	34.22	31	14, 15	64	5120524-1

THIS DRAWING IS A CONTROLLED DOCUMENT.

AWN: B. CARBO 29SEP04
 CHK: R. WERTZ 29SEP04
 APPD: R. WERTZ 29SEP04

TE Connectivity

RCPT ASSY, 1.0mm FH (IEEE1386)
 CONNECTOR

SIZE: CAGE CODE: DRAWING NO: 114-25045
 WEIGHT: 1.00779g
 CUSTOMER DRAWING

SCALE: 10:1 SHEET 1 OF 1 REV A2