

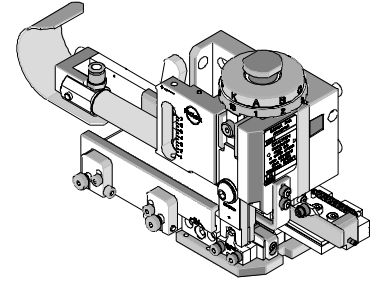

Mini-Mac Applicator Application Tooling Specification Air Feed-Mylar Tape Order No. 63885-3300



FEATURES

- Directly adapts to most crimp presses and automatic wire processors
- Applicator designed to industry standard mounting and shut height of 135.80mm (5.346")
- Conductor and insulation rings allow quick adjustment for conductor and insulation crimp height change
- Quick set-up time; plus the crimp height, track and feed adjustments can be set without removing the applicator from the crimp press

SCOPE

Products: Avikrimp® Snap Plugs and Tongue Terminals 18-22 AWG

Testing

Mechanical

The tensile test, or pull test, is a means of evaluating the mechanical properties of the crimped connections. The following chart shows the UL and government specifications (MIL-T-7928) for various wire sizes. The tensile strength is shown in pounds and indicates the minimum acceptable force to break or separate the terminal from the conductor.

Color Code	Wire Size (AWG)	*UL - 486 A	*UL - 486 C	*UL - 310	*Military Class 2
Yellow	26	3	N/A	N/A	7
Yellow	24	5	N/A	N/A	10
Red	22	8	8	8	15
Red	20	13	10	13	19
Red	18	20	10	20	38
Blue	16	30	15	30	50
Blue	14	50	25	50	70
Yellow	12	70	35	70	110
Yellow	10	80	40	80	150
Red	8	90	45	N/A	225
Blue	6	100	50	N/A	300

*UL - 486 A - Terminals (Copper conductors only)

*UL - 486 C - Butt Splices, Parallel Splices, Closed End Connectors, and Wire Nuts

*UL - 310 - Quick Disconnects, Flag and Couplers

*Military Class 2 - Military Approved Terminals only as listed

Product List

The following is a partial list of the product order numbers and their specifications that this tool is designed to run. Updates to this list are available on www.molex.com.

Terminal No.	Terminal Eng. No.	Wire Size		Insulation Diameter Max.		Strip Length	
		AWG	mm ²	mm	In.	mm	In.
	A-521-10TS	22-18	0.35-0.80	3.70	.145	7.92	.312
	A-635-10XT	22-18	0.35-0.80	3.56	.140	7.92	.312
190230006	AMCT-2XT	22-18	0.35-0.80	3.56	.140	7.92	.312
190250003	AMCT-57T	22-18	0.35-0.80			7.92	.312
190250004	AMCT-5T	22-18	0.35-0.80			7.92	.312
190260005	AMCT-87T	22-18	0.35-0.80			7.92	.312
190340003	A-259XT	22-18	0.35-0.80	3.56	.140	7.92	.312
190340006	A-269XT	22-18	0.35-0.80	3.56	.140	7.92	.312
190350002	A-559T	22-18	0.35-0.80	3.56	.140	7.92	.312
190350004	A-569T	22-18	0.35-0.80	3.56	.140	7.92	.312
190360002	A-859T	22-18	0.35-0.80	3.56	.140	7.92	.312
190360004	A-869BT	22-18	0.35-0.80			7.92	.312
190360005	A-869T	22-18	0.35-0.80			7.92	.312
190540001	A-220-02XT	22-18	0.35-0.80			7.92	.312
190540002	A-220-04XT	22-18	0.35-0.80			7.92	.312
190540003	A-222-10XT	22-18	0.35-0.80			7.92	.312
190540004	A-226-10XT	22-18	0.35-0.80			7.92	.312
190540005	A-226-14XT	22-18	0.35-0.80			7.92	.312
190540006	A-226-56XT	22-18	0.35-0.80			7.92	.312
190540007	A-232-04XT	22-18	0.35-0.80			7.92	.312
190540008	A-233-08XT	22-18	0.35-0.80			7.92	.312
190540009	A-233-10XT	22-18	0.35-0.80			7.92	.312
190540034	A-220-06XT	22-18	0.35-0.80			7.92	.312
190540036	A-221-06XT	22-18	0.35-0.80			7.92	.312
190540038	A-221-08XT	22-18	0.35-0.80			7.92	.312
190540040	A-221-10XT	22-18	0.35-0.80			7.92	.312
190540043	A-222-14XT	22-18	0.35-0.80			7.92	.312
190540045	A-222-56XT	22-18	0.35-0.80			7.92	.312
190540049	A-226-38XT	22-18	0.35-0.80			7.92	.312
190540053	A-232-06XT	22-18	0.35-0.80			7.92	.312
190540055	A-232-08XT	22-18	0.35-0.80			7.92	.312
190550002	A-620-02XT	22-18	0.35-0.80			7.92	.312
190550004	A-620-04XT	22-18	0.35-0.80			7.92	.312
190550007	A-620-06XT	22-18	0.35-0.80			7.92	.312
190550009	A-621-06XT	22-18	0.35-0.80			7.92	.312
190550012	A-621-08XT	22-18	0.35-0.80			7.92	.312
190550015	A-621-10XT	22-18	0.35-0.80			7.92	.312
190550017	A-622-10XT	22-18	0.35-0.80			7.92	.312
190550019	A-622-14XT	22-18	0.35-0.80			7.92	.312
190550021	A-622-56XT	22-18	0.35-0.80			7.92	.312
190550024	A-626-14XT	22-18	0.35-0.80			7.92	.312
190550026	A-626-38XT	22-18	0.35-0.80			7.92	.312
190550028	A-626-56XT	22-18	0.35-0.80			7.92	.312
190550030	A-632-04XT	22-18	0.35-0.80			7.92	.312
190550032	A-632-06XT	22-18	0.35-0.80			7.92	.312
190550034	A-632-08XT	22-18	0.35-0.80			7.92	.312
190550039	A-633-10XT	22-18	0.35-0.80			7.92	.312
190570002	A-520-02T	22-18	0.35-0.80			7.92	.312
190570004	A-520-04T	22-18	0.35-0.80			7.92	.312
190570006	A-520-06T	22-18	0.35-0.80			7.92	.312
190570008	A-521-06T	22-18	0.35-0.80			7.92	.312
190570010	A-521-08T	22-18	0.35-0.80			7.92	.312
190570012	A-521-10T	22-18	0.35-0.80			7.92	.312
190570014	A-522-10T	22-18	0.35-0.80			7.92	.312

Terminal No.	Terminal Eng. No.	Wire Size		Insulation Diameter Max.		Strip Length	
		AWG	mm ²	mm	In.	mm	In.
190570016	A-522-14T	22-18	0.35-0.80			7.92	.312
190570018	A-522-56T	22-18	0.35-0.80			7.92	.312
190570021	A-526-14T	22-18	0.35-0.80			7.92	.312
190570023	A-526-38T	22-18	0.35-0.80			7.92	.312
190570025	A-526-56T	22-18	0.35-0.80			7.92	.312
190570027	A-532-04T	22-18	0.35-0.80			7.92	.312
190570029	A-532-06T	22-18	0.35-0.80			7.92	.312
190570031	A-532-08T	22-18	0.35-0.80			7.92	.312
190570036	A-533-10T	22-18	0.35-0.80			7.92	.312
190580007	A-820-06T	22-18	0.35-0.80			7.92	.312
190580010	A-821-10T	22-18	0.35-0.80			7.92	.312
190580013	A-832-06T	22-18	0.35-0.80			7.92	.312
190800002	A-2006-MSXT	22-18	0.35-0.80			7.92	.312
190810002	A-5006-MST	22-18	0.35-0.80			7.92	.312
190890011	A-292-06XT	22-18	0.35-0.80			7.92	.312
190890045	A-205-04XT	22-18	0.35-0.80			7.92	.312
190890046	A-205-06XT	22-18	0.35-0.80			7.92	.312
190890047	A-206-06XT	22-18	0.35-0.80			7.92	.312
190890048	A-206-08XT	22-18	0.35-0.80			7.92	.312
190890049	A-206-10XT	22-18	0.35-0.80			7.92	.312
190890050	A-214-04XT	22-18	0.35-0.80			7.92	.312
190890051	A-214-06XT	22-18	0.35-0.80			7.92	.312
190890052	A-214-08XT	22-18	0.35-0.80			7.92	.312
190890053	A-292-08XT	22-18	0.35-0.80			7.92	.312
190890054	A-292-10XT	22-18	0.35-0.80			7.92	.312
190890055	A-295-06XT	22-18	0.35-0.80			7.92	.312
190890056	A-295-08XT	22-18	0.35-0.80			7.92	.312
190890057	A-295-10XT	22-18	0.35-0.80			7.92	.312
190890058	A-298-04XT	22-18	0.35-0.80			7.92	.312
190890059	A-298-06XT	22-18	0.35-0.80			7.92	.312
190890060	A-298-08XT	22-18	0.35-0.80			7.92	.312
190890061	A-298-10XT	22-18	0.35-0.80			7.92	.312
190910002	A-605-04XT	22-18	0.35-0.80			7.92	.312
190910004	A-605-06XT	22-18	0.35-0.80			7.92	.312
190910007	A-606-06XT	22-18	0.35-0.80			7.92	.312
190910009	A-606-08XT	22-18	0.35-0.80			7.92	.312
190910011	A-606-10XT	22-18	0.35-0.80			7.92	.312
190910013	A-614-04XT	22-18	0.35-0.80			7.92	.312
190910015	A-614-06XT	22-18	0.35-0.80			7.92	.312
190910017	A-614-08XT	22-18	0.35-0.80			7.92	.312
190910019	A-692-06XT	22-18	0.35-0.80			7.92	.312
190910021	A-692-08XT	22-18	0.35-0.80			7.92	.312
190910023	A-692-10XT	22-18	0.35-0.80			7.92	.312
190910025	A-695-06XT	22-18	0.35-0.80			7.92	.312
190910027	A-695-08XT	22-18	0.35-0.80			7.92	.312
190910029	A-695-10XT	22-18	0.35-0.80			7.92	.312
190910031	A-698-04XT	22-18	0.35-0.80			7.92	.312
190910033	A-698-06XT	22-18	0.35-0.80			7.92	.312
190910035	A-698-08XT	22-18	0.35-0.80			7.92	.312
190910037	A-698-10XT	22-18	0.35-0.80			7.92	.312
190940002	A-505-04T	22-18	0.35-0.80			7.92	.312
190940004	A-505-06T	22-18	0.35-0.80			7.92	.312
190940007	A-506-06T	22-18	0.35-0.80			7.92	.312
190940009	A-506-08T	22-18	0.35-0.80			7.92	.312

Air Feed Mylar Tape Applicator

Terminal No.	Terminal Eng. No.	Wire Size		Insulation Diameter Max.		Strip Length	
		AWG	mm ²	mm	In.	mm	In.
190940011	A-506-10T	22-18	0.35-0.80			7.92	.312
190940012	A-514-04T	22-18	0.35-0.80			7.92	.312
190940014	A-514-06T	22-18	0.35-0.80			7.92	.312
190940017	A-514-08T	22-18	0.35-0.80			7.92	.312
190940020	A-592-06T	22-18	0.35-0.80			7.92	.312
190940022	A-592-08T	22-18	0.35-0.80			7.92	.312
190940024	A-592-10T	22-18	0.35-0.80			7.92	.312
190940026	A-595-06T	22-18	0.35-0.80			7.92	.312
190940028	A-595-08T	22-18	0.35-0.80			7.92	.312
190940030	A-595-10T	22-18	0.35-0.80			7.92	.312
190940032	A-598-04T	22-18	0.35-0.80			7.92	.312
190940034	A-598-06T	22-18	0.35-0.80			7.92	.312
190940036	A-598-08T	22-18	0.35-0.80			7.92	.312
190940038	A-598-10T	22-18	0.35-0.80			7.92	.312
191190005	A-215-06XT	22-18	0.35-0.80			7.92	.312
191190008	A-215-08XT	22-18	0.35-0.80			7.92	.312
191190013	A-2461-06XT	22-18	0.35-0.80			7.92	.312
191190050	A-215-04XT	22-18	0.35-0.80			7.92	.312
191190051	A-215-10XT	22-18	0.35-0.80			7.92	.312
191190052	A-290-06XT	22-18	0.35-0.80			7.92	.312
191190053	A-290-08XT	22-18	0.35-0.80			7.92	.312
191190054	A-290-10XT	22-18	0.35-0.80			7.92	.312
191190056	A-293-06XT	22-18	0.35-0.80			7.92	.312
191190057	A-293-08XT	22-18	0.35-0.80			7.92	.312
191190058	A-293-10XT	22-18	0.35-0.80			7.92	.312
191190059	A-296-04XT	22-18	0.35-0.80			7.92	.312
191190060	A-296-06XT	22-18	0.35-0.80			7.92	.312
191190061	A-296-08XT	22-18	0.35-0.80			7.92	.312
191200004	A-615-04XT	22-18	0.35-0.80			7.92	.312
191200006	A-615-06XT	22-18	0.35-0.80			7.92	.312
191200008	A-615-08XT	22-18	0.35-0.80			7.92	.312
191200009	A-615-10XT	22-18	0.35-0.80			7.92	.312
191200015	A-690-06XT	22-18	0.35-0.80			7.92	.312
191200017	A-690-08XT	22-18	0.35-0.80			7.92	.312
191200019	A-690-10XT	22-18	0.35-0.80			7.92	.312
191200021	A-693-06XT	22-18	0.35-0.80			7.92	.312
191200023	A-693-08XT	22-18	0.35-0.80			7.92	.312
191200025	A-693-10XT	22-18	0.35-0.80			7.92	.312
191200028	A-696-04XT	22-18	0.35-0.80			7.92	.312
191200030	A-696-06XT	22-18	0.35-0.80			7.92	.312
191200032	A-696-08XT	22-18	0.35-0.80			7.92	.312
191250002	A-515-04T	22-18	0.35-0.80			7.92	.312
191250004	A-515-06T	22-18	0.35-0.80			7.92	.312
191250006	A-515-08T	22-18	0.35-0.80			7.92	.312
191250008	A-515-10T	22-18	0.35-0.80			7.92	.312
191250014	A-590-06T	22-18	0.35-0.80			7.92	.312
191250016	A-590-08T	22-18	0.35-0.80			7.92	.312
191250018	A-590-10T	22-18	0.35-0.80			7.92	.312
191250020	A-593-06T	22-18	0.35-0.80			7.92	.312
191250022	A-593-08T	22-18	0.35-0.80			7.92	.312
191250024	A-593-10T	22-18	0.35-0.80			7.92	.312
191250026	A-596-04T	22-18	0.35-0.80			7.92	.312
191250028	A-596-06T	22-18	0.35-0.80			7.92	.312
191250030	A-596-08T	22-18	0.35-0.80			7.92	.312
191420001	A-234-06XT	22-18	0.35-0.80			7.92	.312
191420002	A-234-08XT	22-18	0.35-0.80			7.92	.312
191420004	A-235-06XT	22-18	0.35-0.80			7.92	.312
191420006	A-235-08XT	22-18	0.35-0.80			7.92	.312
191420008	A-235-10XT	22-18	0.35-0.80			7.92	.312
191420009	A-238-06XT	22-18	0.35-0.80			7.92	.312
191420056	A-234-04XT	22-18	0.35-0.80			7.92	.312
191420057	A-234-10XT	22-18	0.35-0.80			7.92	.312

Terminal No.	Terminal Eng. No.	Wire Size		Insulation Diameter Max.		Strip Length	
		AWG	mm ²	mm	In.	mm	In.
191420058	A-238-04XT	22-18	0.35-0.80			7.92	.312
191420059	A-238-08XT	22-18	0.35-0.80			7.92	.312
191420060	A-291-06XT	22-18	0.35-0.80			7.92	.312
191420061	A-291-08XT	22-18	0.35-0.80			7.92	.312
191420062	A-291-10XT	22-18	0.35-0.80			7.92	.312
191420063	A-294-06XT	22-18	0.35-0.80			7.92	.312
191420064	A-294-08XT	22-18	0.35-0.80			7.92	.312
191420065	A-294-10XT	22-18	0.35-0.80			7.92	.312
191420066	A-297-04XT	22-18	0.35-0.80			7.92	.312
191420067	A-297-06XT	22-18	0.35-0.80			7.92	.312
191420068	A-297-08XT	22-18	0.35-0.80			7.92	.312
191430002	A-634-04XT	22-18	0.35-0.80			7.92	.312
191430004	A-634-06XT	22-18	0.35-0.80			7.92	.312
191430007	A-634-08XT	22-18	0.35-0.80			7.92	.312
191430009	A-634-10XT	22-18	0.35-0.80			7.92	.312
191430011	A-635-06XT	22-18	0.35-0.80			7.92	.312
191430013	A-635-08XT	22-18	0.35-0.80			7.92	.312
191430016	A-638-04XT	22-18	0.35-0.80			7.92	.312
191430019	A-638-06XT	22-18	0.35-0.80			7.92	.312
191430020	A-638-08XT	22-18	0.35-0.80			7.92	.312
191430022	A-691-06XT	22-18	0.35-0.80			7.92	.312
191430024	A-691-08XT	22-18	0.35-0.80			7.92	.312
191430026	A-691-10XT	22-18	0.35-0.80			7.92	.312
191430028	A-694-06XT	22-18	0.35-0.80			7.92	.312
191430030	A-694-08XT	22-18	0.35-0.80			7.92	.312
191430032	A-694-10XT	22-18	0.35-0.80			7.92	.312
191430034	A-697-04XT	22-18	0.35-0.80			7.92	.312
191430036	A-697-06XT	22-18	0.35-0.80			7.92	.312
191430038	A-697-08XT	22-18	0.35-0.80			7.92	.312
191710002	A-210-06XT	22-18	0.35-0.80			7.92	.312
191710004	A-210-08XT	22-18	0.35-0.80			7.92	.312
191710006	A-210-10XT	22-18	0.35-0.80			7.92	.312
191740002	A-510-06T	22-18	0.35-0.80			7.92	.312
191740004	A-510-08T	22-18	0.35-0.80			7.92	.312
191740006	A-510-10T	22-18	0.35-0.80			7.92	.312
191750002	A-610-06XT	22-18	0.35-0.80			7.92	.312
191750004	A-610-08XT	22-18	0.35-0.80			7.92	.312
191750006	A-610-10XT	22-18	0.35-0.80			7.92	.312
191960001	A-534-04T	22-18	0.35-0.80			7.92	.312
191960002	A-534-06T	22-18	0.35-0.80			7.92	.312
191960003	A-534-08T	22-18	0.35-0.80			7.92	.312
191960004	A-534-10T	22-18	0.35-0.80			7.92	.312
191960006	A-535-06T	22-18	0.35-0.80			7.92	.312
191960008	A-535-08T	22-18	0.35-0.80			7.92	.312
191960010	A-535-10T	22-18	0.35-0.80			7.92	.312
191960011	A-538-04T	22-18	0.35-0.80			7.92	.312
191960013	A-538-06T	22-18	0.35-0.80			7.92	.312
191960014	A-538-08T	22-18	0.35-0.80			7.92	.312
191960015	A-591-06T	22-18	0.35-0.80			7.92	.312
191960016	A-591-08T	22-18	0.35-0.80			7.92	.312
191960017	A-591-10T	22-18	0.35-0.80			7.92	.312
191960018	A-594-06T	22-18	0.35-0.80			7.92	.312
191960019	A-594-08T	22-18	0.35-0.80			7.92	.312
191960020	A-594-10T	22-18	0.35-0.80			7.92	.312
191960021	A-597-04T	22-18	0.35-0.80			7.92	.312
191960022	A-597-06T	22-18	0.35-0.80			7.92	.312
191960023	A-597-08T	22-18	0.35-0.80			7.92	.312
191970003	A-834-08T	22-18	0.35-0.80			7.92	.312
191970008	A-838-06T	22-18	0.35-0.80			7.92	.312

DEFINITION OF TERMS

The following illustrations are a generic terminal representation and not an exact image of any terminal listed in the scope.

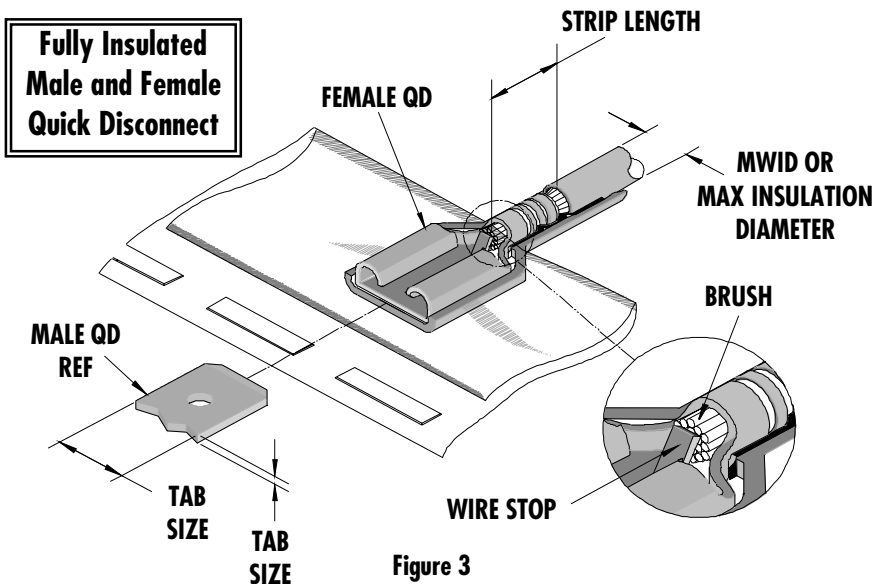
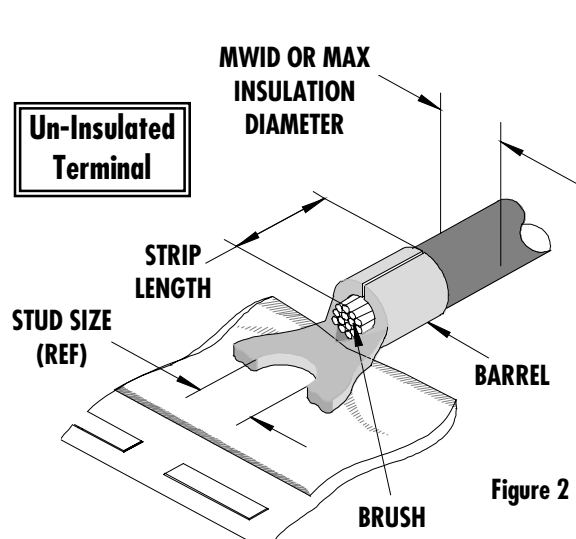
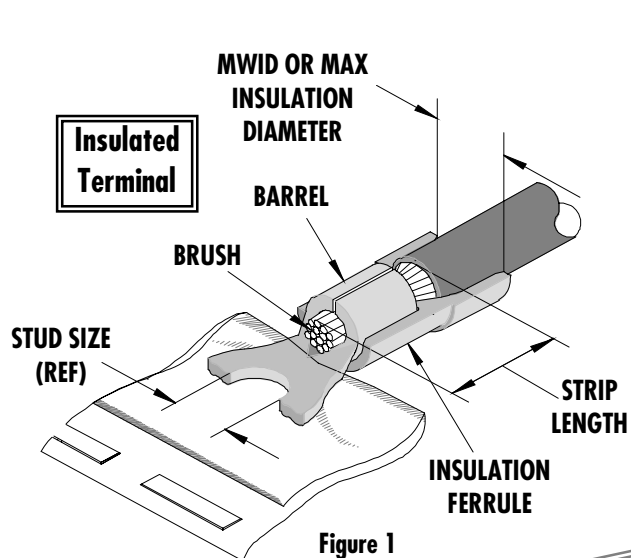

Tool Calibration

To recalibrate this applicator, make sure the power is completely shut off on the press.

The Mini-Mac applicator must be properly installed in the press. Crimping dies must be properly installed in the Mini-Mac applicator. The recommended method of measuring the crimp height of the conductor dies is the soft metal slug method, (See Figure 4).

1. The slug must have a diameter 0.51 mm (.020") larger than the "X" No Go dimension before crimping.
2. Place the soft metal slug (solder) into the nest of the bottom die and crimp (by hand cycling the press) similar to a terminal. The crimp height can be measured with a blade type micrometer or dial caliper, (Dimension "X").
3. Adjustment of the crimp height can be accomplished by indexing the conductor cam. The letter "A" gives the loosest position and "K" gives the tightest position. A total adjustment of 0.50mm (.020") can be achieved by adjusting the conductor cam.

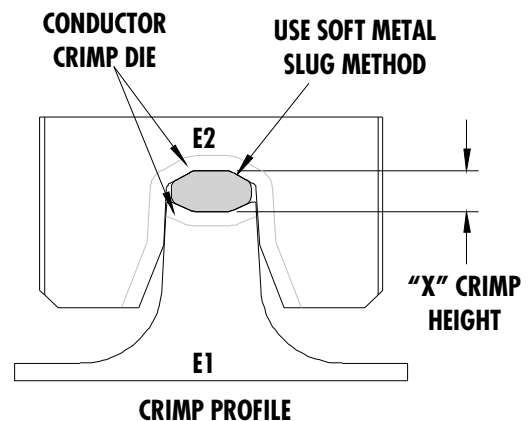

Use soft metal slug (solder) method to measure the "X" dimension. Verify tooling crimp height calibration by referring to the Go/No Go dimensions shown in the chart below.

Figure 4

Note: If the crimp height is too tight on the setting "A", check the shut height of the press. See the Industrial Mini-Mac Applicator Manual Section 2.1 for adjustments.

CRIMP SPECIFICATIONS

Wire Size		"X" Dimension Conductor Crimp						Pull Force Min.	
AWG	mm ²	Mean		Go		No Go		Lbs	N
		In	mm	In	mm	In	mm		
22	0.35	.108	2.74	.105	2.67	.112	2.84	8.0	35.6
20	0.50	.108	2.74	.105	2.67	.112	2.84	13.0	57.8
18	0.80	.108	2.74	.105	2.67	.112	2.84	20.0	90.0

Pull Force should be measured with no influence from the insulation crimp. The above specifications are guidelines to an optimum crimp.

PARTS LIST

Mini-Mac Applicator 63885-3300				
Item	Order No	Engineering No.	Description	Quantity
Perishable Tooling				
	63885-3370	63885-3370	Tool Kit (All "Y" Items)	REF
1	63465-0029	63465-0029	Conductor Punch	1 Y
2	63464-0028	63464-0028	Conductor Anvil	1 Y
3	63463-0028	63463-0028	Insulation Punch	1 Y
4	63462-0030	63462-0030	Insulation Anvil	1 Y
Other Components (Ref. 50050)				
31	63466-0912	63466-0912	Anvil Mount	1
32	63466-0913	63466-0913	Terminal Support	1
33	63443-0021	63443-0021	Lower Tooling Key	1
42	63466-0921	63466-0921	Terminal Stripping Blade	1
51	63600-1290	63600-1290	Washer	1
52	63890-0866	63890-0866	Collar-6.4mm Lg.	1
53	63890-0867	63890-0867	Collar-7.7mm Lg.	1
Frame				
81	63801-3301	63801-3301	Air Feed Applicator Frame Head	REF
82	63801-3281	63801-3281	Base	REF
83	63801-5850	63801-5850	Track Assembly	REF
84	63801-3390	63801-3390	Air Kit	REF
Hardware				
91	N/A	N/A	M3 by 12 Lg SHCS	1**
92	N/A	N/A	M4 by 10 Lg SHCS	2**
93	N/A	N/A	M4 by 16 Lg. SHCS	1**
94	N/A	N/A	M4 by 45 Lg. SHCS	1**
95	N/A	N/A	M8 by 30 Lg. BHCS	1**
96	N/A	N/A	3mm by 6 Lg. Roll Pin	1**
** Available from an industrial supply company such as MSC (1-800-645-7270).				

Note: Crimp profiles used in 63885-3300 are equivalent to 19032-0013/MMT-A-510 and 19288-0004/ATP-A-510 (UL file number E32244).

Assembly Drawing

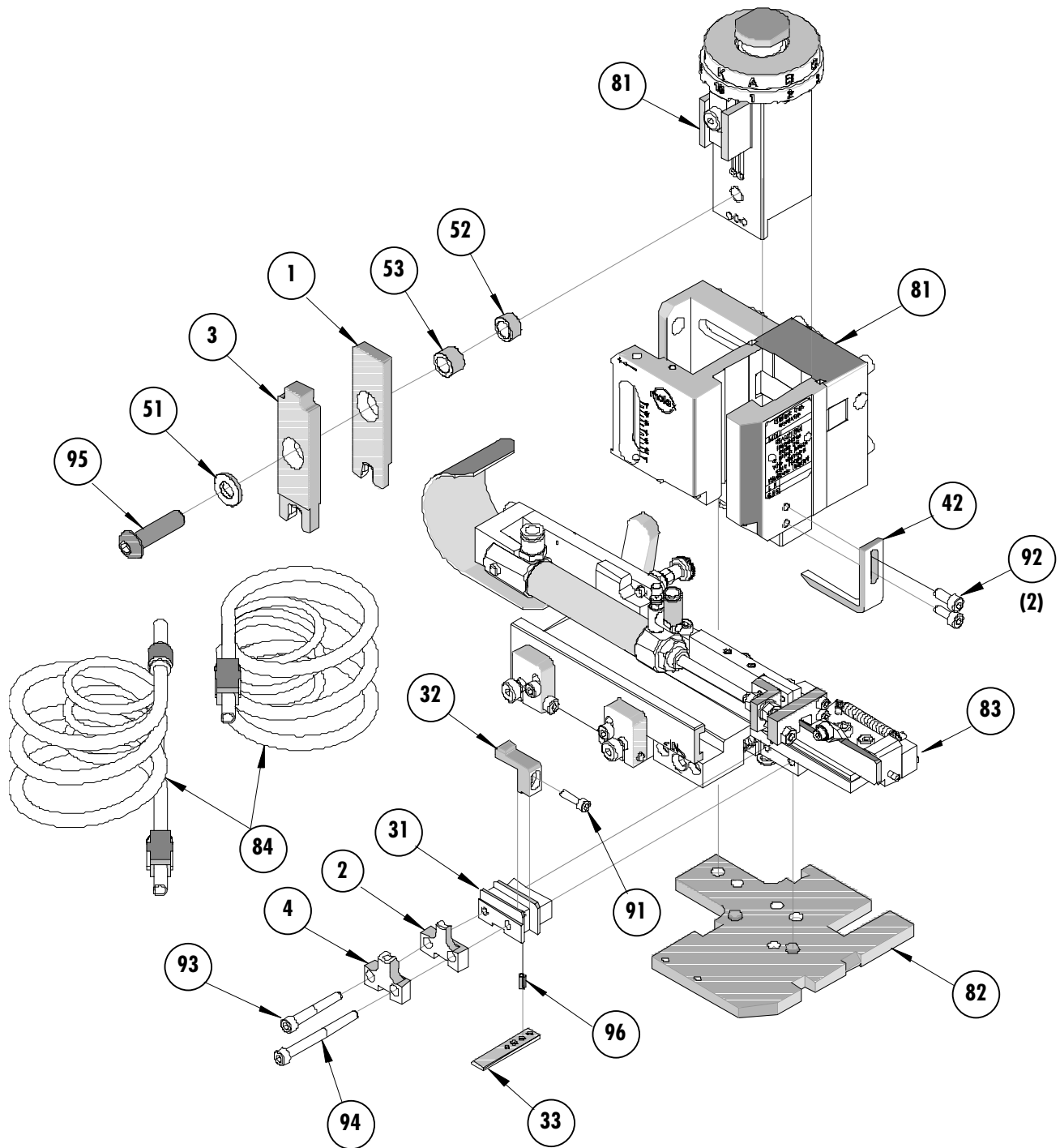

Figure 5

NOTES

1. Molex recommends an extra perishable tooling kit be maintained at your facility.
2. Verify tooling alignment by manually cycling the press with applicator before crimping under power. Check that all screws are tight.
3. Slugs, terminals, dirt, and oil should be kept clear of work area.
4. Wear safety glasses at all times.
5. For recommended maintenance refer to the Mini-Mac Applicator Manual (Document no. 63880-0000).

CAUTION: This applicator should only be used in a press with a shut height of 135.80 mm (5.346"). Tooling damage could result at a lower setting.

CAUTION: To prevent injury, never operate this applicator without the guards supplied with the press or wire-processing machine in place. Reference the press or wire processing manufacturer's instruction manual.

CAUTION: Molex crimp specifications are valid only when used with Molex terminals, applicators and tooling.

Contact Information

For more information on Molex application tooling please contact Molex at 1-800-786-6539.

Molex Application Tooling Group

1150 E. Diehl Road
Naperville, IL 60563
Tel: (630) 969-4550
Fax: (630) 505-0049

Visit our Web site at <http://www.molex.com>