



# TERABEE

## TeraRanger Evo 40m

TeraRanger Evo 40m is a versatile, long-range Time-of-Flight distance sensor. With its 40 meters detection range and an update rate of up to 240Hz, it offers high-performance in a compact and low-cost design. This sensor module is ideally suited to navigation and collision-avoidance for robotics, level sensing applications and a host of other IoT applications.

## Key features

- Infrared Time-of-Flight technology
- Up to 40 meters detection range
- Small and lightweight design (from 9 grams)
- USB, I2C and UART clip-on interchangeable interfaces
- Compatible with Arduino, Raspberry Pi, Pixhawk and ROS
- Operates in low light and complete darkness
- Product design optimized for OEM and easy integration

## Applications



Robot navigation,  
anti-collision



Drone obstacle  
avoidance



Level monitoring  
(silos, containers, etc.)

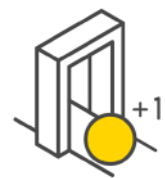

Presence detection,  
object counting

# Technical specifications

Product code	TR-EVO-40M
<b>Performance</b>	
Detection principle	Infrared Time-of-Flight
Range *	0.5 ~ 40 m indoor
	0.5 ~ (10 - 40 m) outdoor
Update rate	Up to 240 readings per second
Output resolution	0.5cm below 14m, 2cm from 14m
Accuracy	±4cm in the first 14m, 1.5% above 14m
Field of View	Approx. 2°
<b>Electronics</b>	
Supply voltage	5V DC +/-5%
Supply current (min-max)	90mA - 330mA
<b>Communication</b>	
Interfaces	USB 2.0 Micro-B
	UART, +3.3V level, 115200,8,N,1
	IC2, +3.3V level, 400kHz
Connectors	Single 9 pin Hirose DF13
	Micro USB
<b>Mechanical data</b>	
Dimensions	Approx. 29x29x22mm (sensor + backboard)
Weight	9 g (sensor) + 3 g (backboard)
Eye safety	Yes (CE certified)

*\*Specifications are derived from tests in controlled conditions. Bright sunlight, target surface reflectivity and other variables will affect sensor performance. The combination of very bright sunshine and low reflectivity targets (such as grass) can reduce maximum range to 10m or less. For additional information, please find the following [test results report](#).*

## Modular Evo Design

The sensor comprises two parts; an opto-electronic sensing device (black module, 9g) and a choice of interface backboard (yellow module, 3g). Simply clip your preferred interface board to the sensor. USB and I2C/UART backboards are available, but custom backboards can also be made to support specific applications. This two-part design alleviates the need to use adapters and converters.

Drivers for ROS (Robot Operating System) and popular drone flight controllers are also in development, or available, adding to the plug and play convenience of our Evo series sensors.

## Dimensions

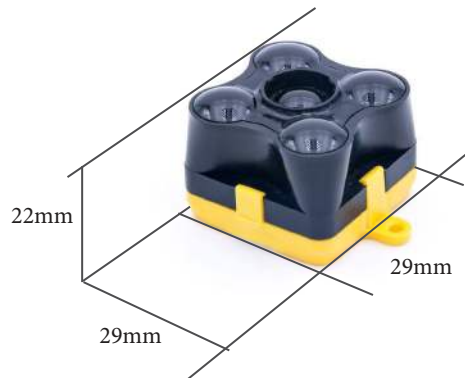

**Have any questions? Contact us today!**