

THIS DRAWING IS UNPUBLISHED. RELEASED FOR PUBLICATION
 © COPYRIGHT - By - ALL RIGHTS RESERVED.

LOC		DIST		REVISIONS			
GP	00	P	LTR	DESCRIPTION	DATE	DWN	APVD
		U		REVISED PER ECO-14-011808	12AUG2014	AP	SB

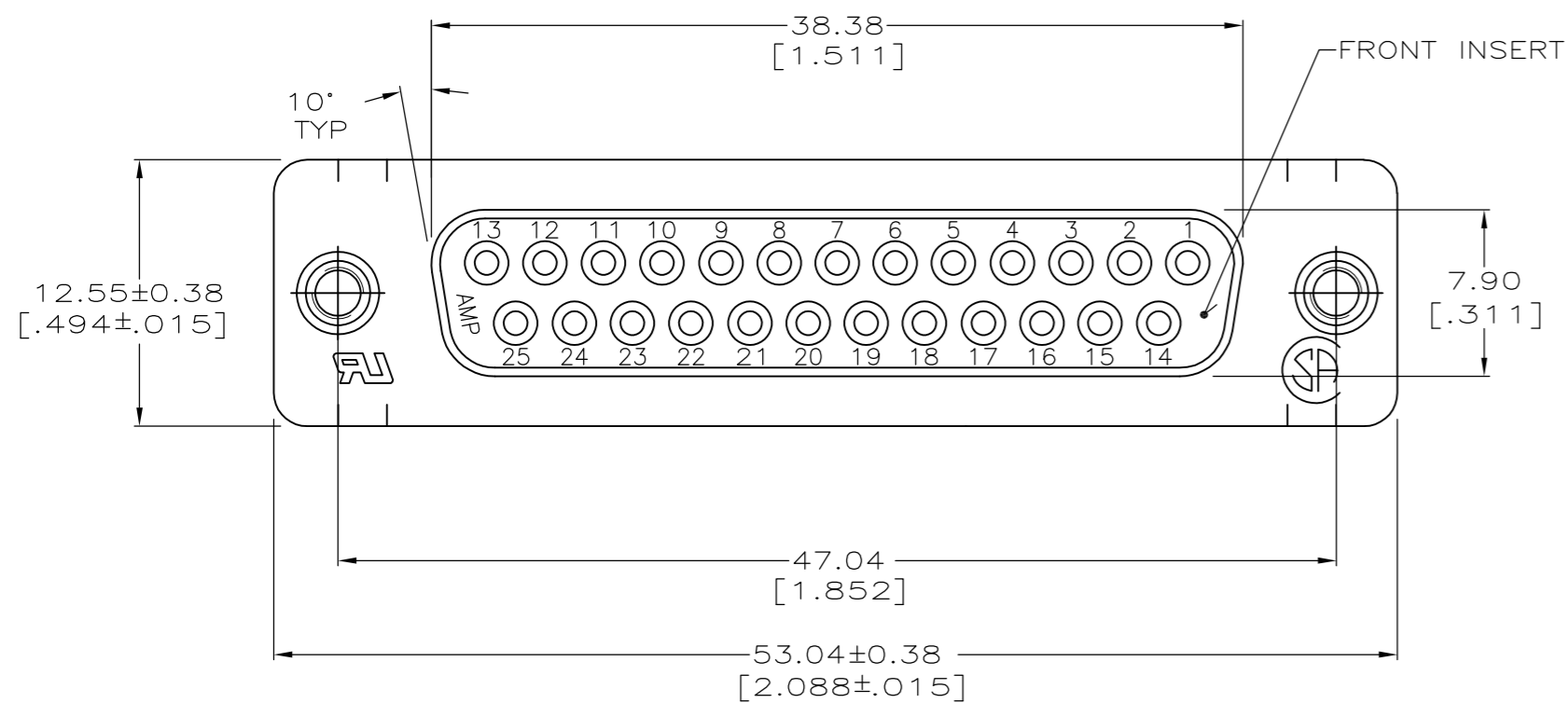

- 1 INSERTS: GLASS-FILLED PBT OR GLASS-FILLED NYLON, UL94V-0 RATED. COLOR: BLACK.
CONTACTS: PHOSPHOR BRONZE
SHELLS: CARBON STEEL
CLINCH NUT: CARBON STEEL
- 2 GOLD FLASH FOR LENGTH OF 2.54 [.100] MIN FROM MATING END, 2.54µm [.000100] MIN TIN OR TIN-LEAD FOR A LENGTH OF DIMENSION A FROM OPPOSITE END, BOTH OVER 1.27µm [.000050] MIN NICKEL.
- 3 0.76µm [.000030] MIN GOLD FOR LENGTH OF 2.54 [.100] MIN FROM MATING END, 2.54µm [.000100] MIN TIN OR TIN-LEAD FOR A LENGTH OF DIMENSION A FROM OPPOSITE END, BOTH OVER 1.27µm [.000050] MIN NICKEL.
-OR-
GOLD FLASH OVER PALLADIUM-NICKEL, 0.76µm [.000030] MIN TOTAL FOR A LENGTH OF 2.54 [.100] MIN FROM MATING END, 2.54µm [.000100] MIN TIN OR TIN-LEAD FOR A LENGTH OF DIMENSION A FROM OPPOSITE END, BOTH OVER 1.27µm [.000050] MIN NICKEL.
- 4 SHELLS: 5.08µm [.000200] MIN TIN OVER 2.54µm [.000100] MIN COPPER
CLINCH NUT: ZINC

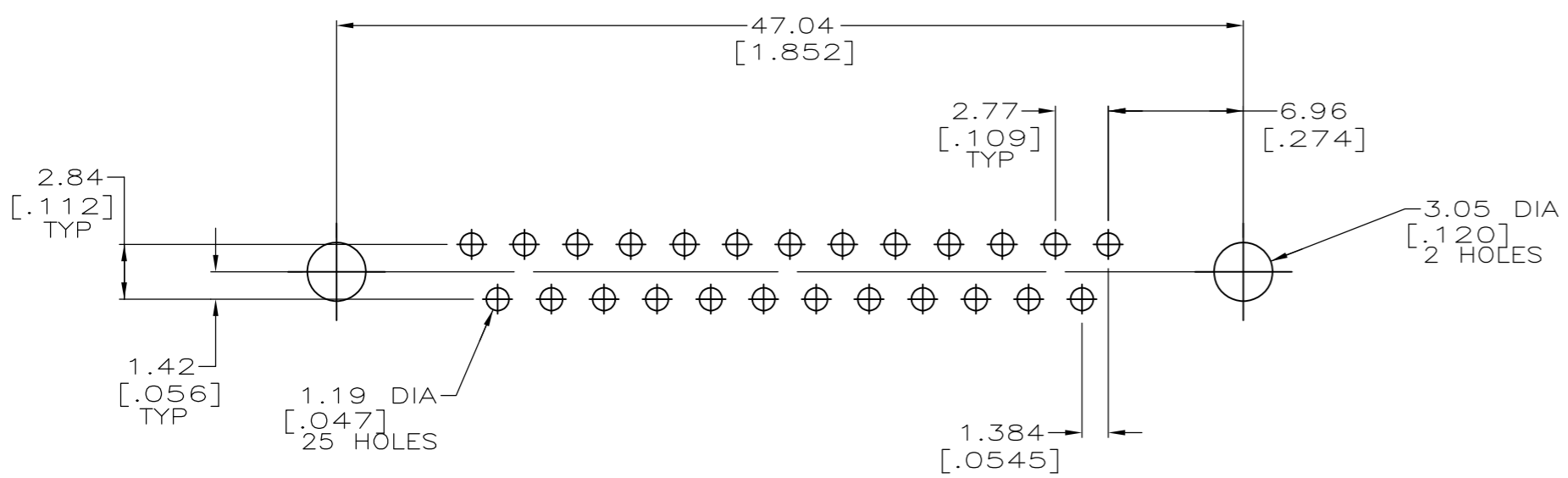
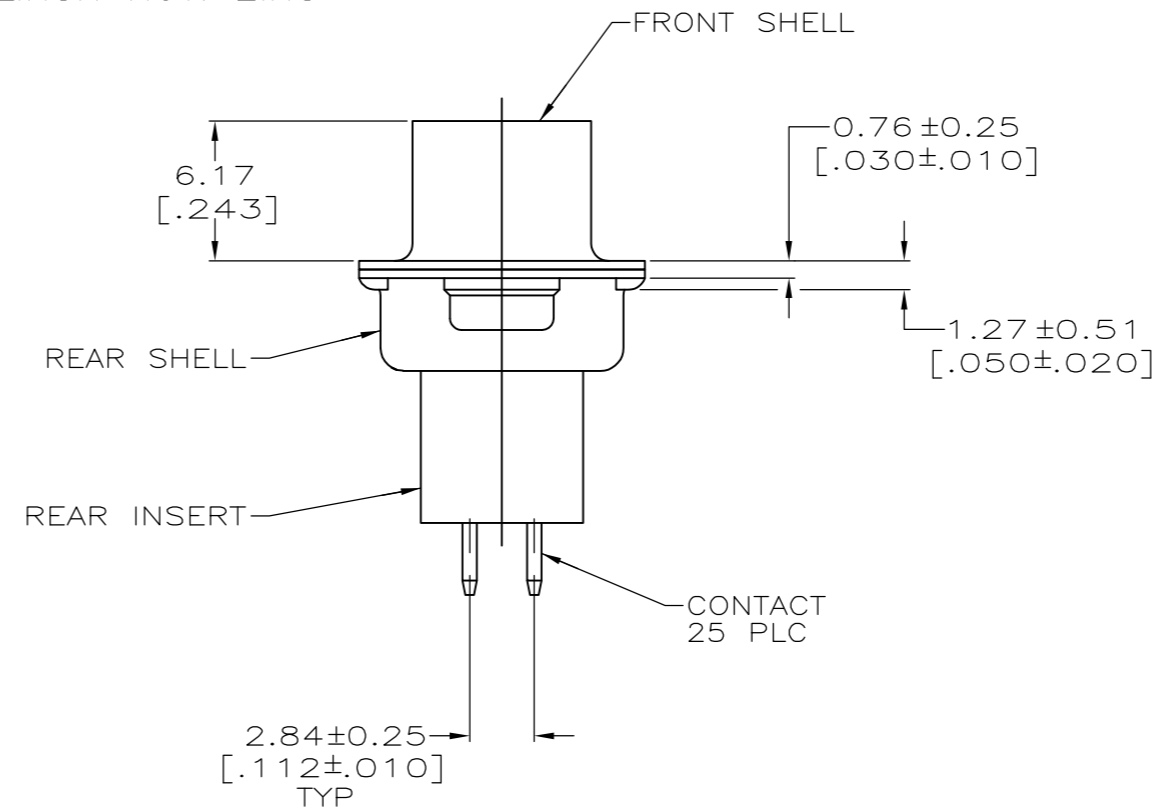
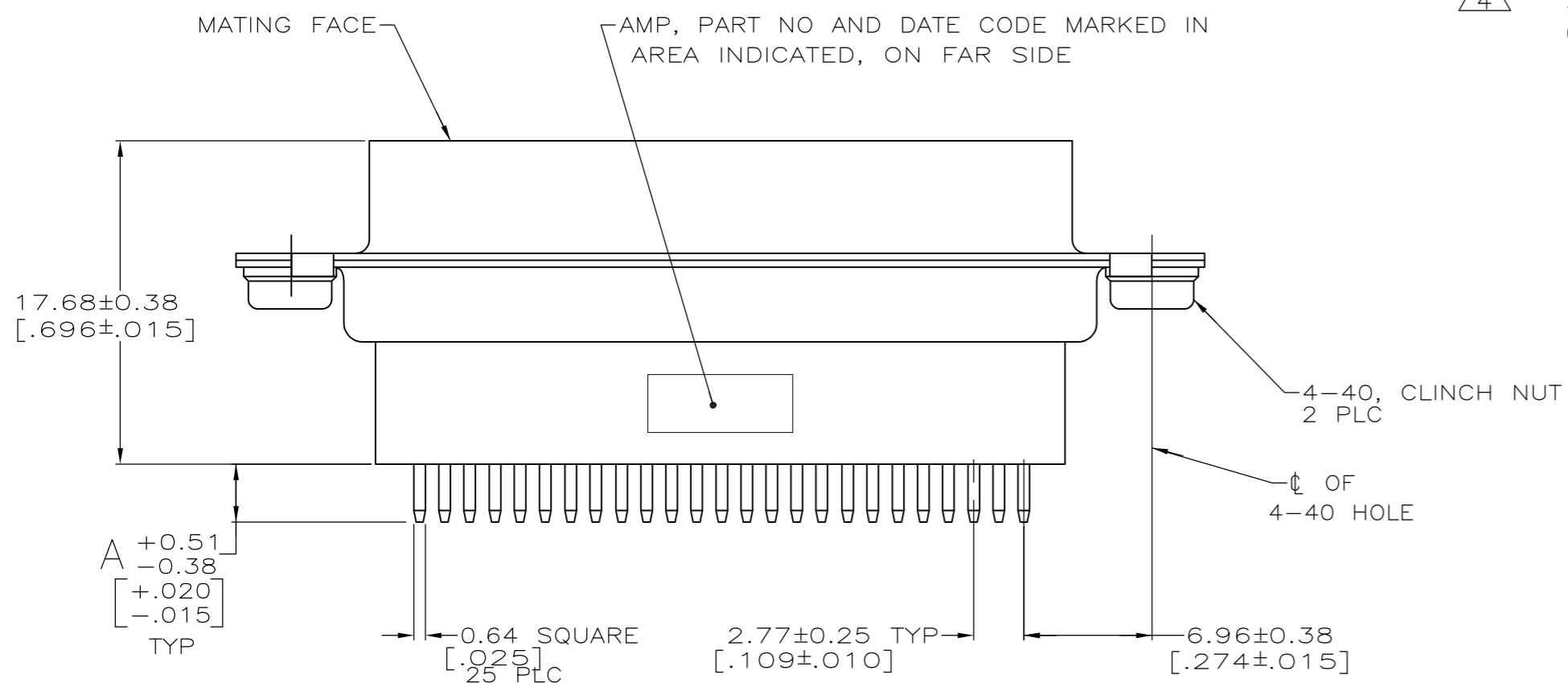

RECOMMENDED PC BOARD MOUNTING DIMENSIONS

OBSOLETE	3.18 [.125]	3		745886-9
SUPSD BY 745886-1	4.78 [.188]	3	2	745886-8
SUPSD BY 745886-1	4.78 [.188]	3		745886-7
OBSOLETE	16.54 [.651]	3	2	745886-6
OBSOLETE	16.54 [.651]	3		745886-5
OBSOLETE	10.85 [.427]	3	2	745886-4
OBSOLETE	10.85 [.427]	3		745886-3
	3.18 [.125]	3	2	745886-2
	3.18 [.125]	3		745886-1
	DIMENSION A			
			CONTACT FINISH	PART NUMBER

THIS DRAWING IS A CONTROLLED DOCUMENT.		DWN J McCLINTON 12-5-89	TE TE Connectivity	
DIMENSIONS: mm [INCHES]		CHK R. STONE 2-1-90		
TOLERANCES UNLESS OTHERWISE SPECIFIED:		APVD -	NAME	
0 PLC ± -	1 PLC ± -	PRODUCT SPEC 108-40025	RECEPTACLE ASSEMBLY, SIZE 3, 25 POSN, VERTICAL, FULL METAL SHELL, AMPLIMITE® HD-20	
2 PLC ± 0.13 [.005]	3 PLC ± -	APPLICATION SPEC 114-40013	SIZE A2	CAGE CODE 00779
4 PLC ± -	ANGLES ± -	WEIGHT -	DRAWING NO C=745886	RESTRICTED TO -
MATERIAL 1	FINISH 4	CUSTOMER DRAWING	SCALE 3:1	SHEET 1 of 1
CONTACTS: SEE TABLE			REV U	