

REVISIONS					
P	LTR	DESCRIPTION	DATE	DWN	APVD
	H2	REVISED PER ECN-21-122181	18OCT2021	RZ	WK

1. USE INSTRUCTION SHEET 1799-1

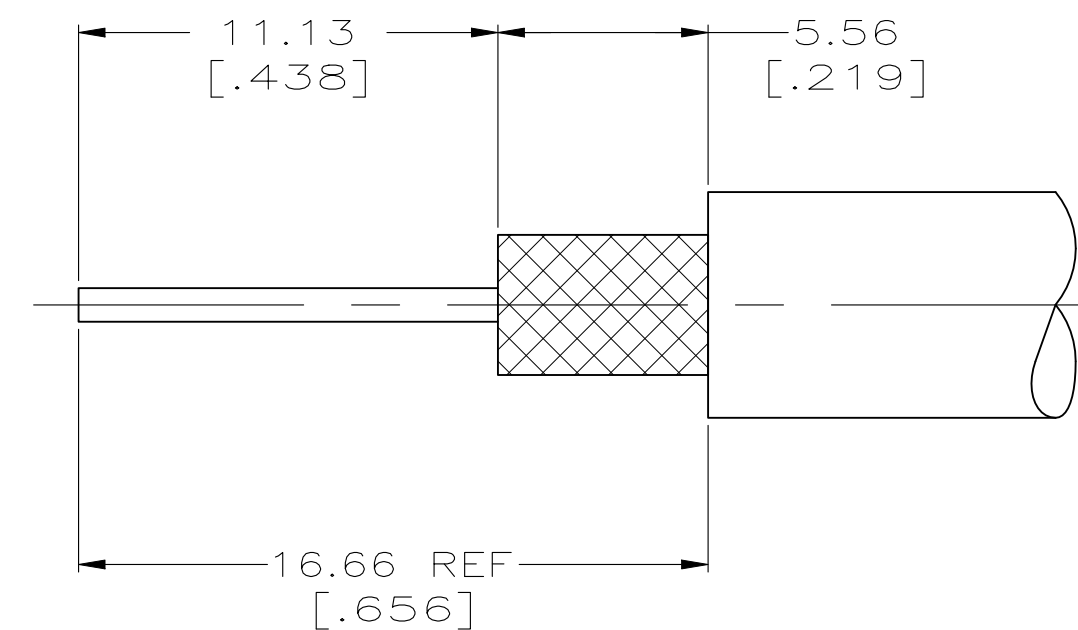
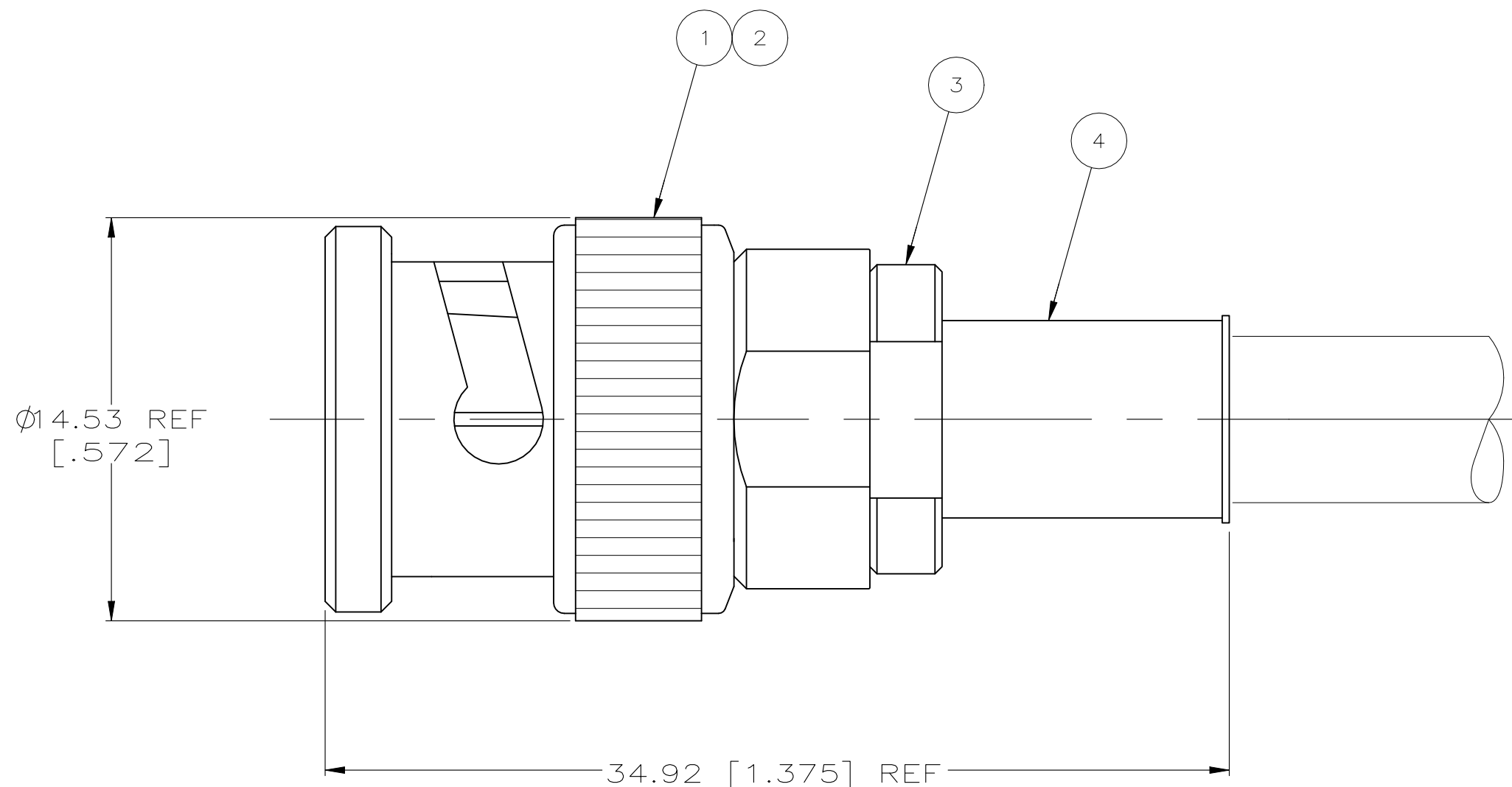

RECOMMENDED STRIP LENGTH

OBSOLETE	-	-	-	-	-	-	7-330358-1
	RG-142/U, 142A/U, 142B/U	693331-1	9-329099-2	9-50780-3	2-329106-1	9-329804-0	2-330358-2
SUPSD BY 225395-5	RG-141/U, 141A/U	693331	330478	1-50780-3	2-329106-1	329804	2-330358-1
OBSOLETE	-	-	-	-	-	-	330358
	CABLE	CRIMP TOOL	④ FERRULE QTY=1	③ CRIMP END ASSEMBLY QTY=1	② GASKET QTY=1	① PLUG ASSEMBLY QTY=1	PART NUMBER

THIS DRAWING IS A CONTROLLED DOCUMENT.

DWN	14FEB96	MICHAEL E. COWHER
CHK	15FEB96	FRANK P. MORANA
APVD	-	-
PRODUCT SPEC	-	-
APPLICATION SPEC	-	-
WEIGHT	0.000000	A2 00779 C=330358
CUSTOMER DRAWING	SCALE 5:1	SHEET 1 of 1

TE Connectivity
PLUG, BNC