

LOC		DIST		REVISIONS			
P	LTR	DESCRIPTION	DATE	DWN	APVD		
CM	53	H1	REVISED PER ECR-21-118222	25-JUL-22	AW	VS	

- PARTS COMPLY TO AMP SOLDERABILITY SPECIFICATION 109-11-3.
- △ CIRCUIT IDENTIFICATION CHARACTERS ARE ADJACENT TO THE INDICATED CAVITIES, BUT LOCATION AND ORIENTATION MAY DIFFER FROM PRINT.
- DIMENSIONS IN BRACKETS ARE IN INCHES.
- DIMENSIONS SHOWN REPRESENT PRODUCT IN DRY CONDITION. ADDITIONAL 2% GROWTH DUE TO END USE LOCATION MOISTURE ABSORPTION MAY OCCUR AND SHOULD BE ACCOUNTED FOR.

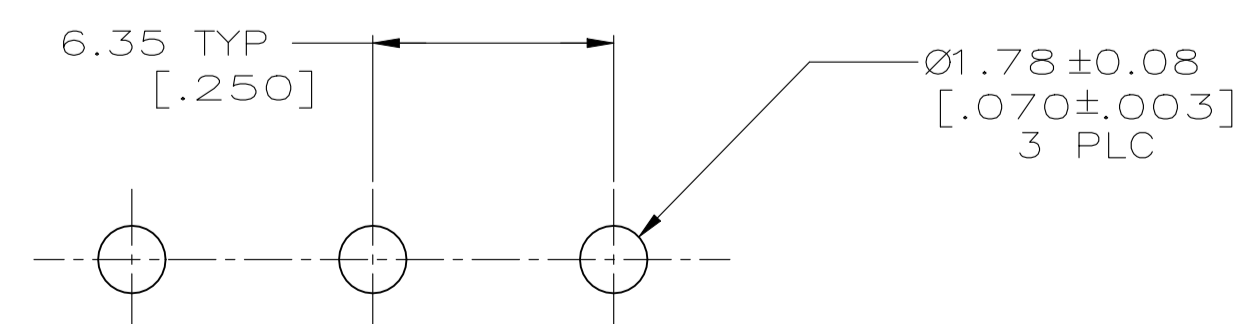

RECOMMENDED MOUNTING HOLE PATTERN FOR 3.18 [.125] THICK P.C. BOARD

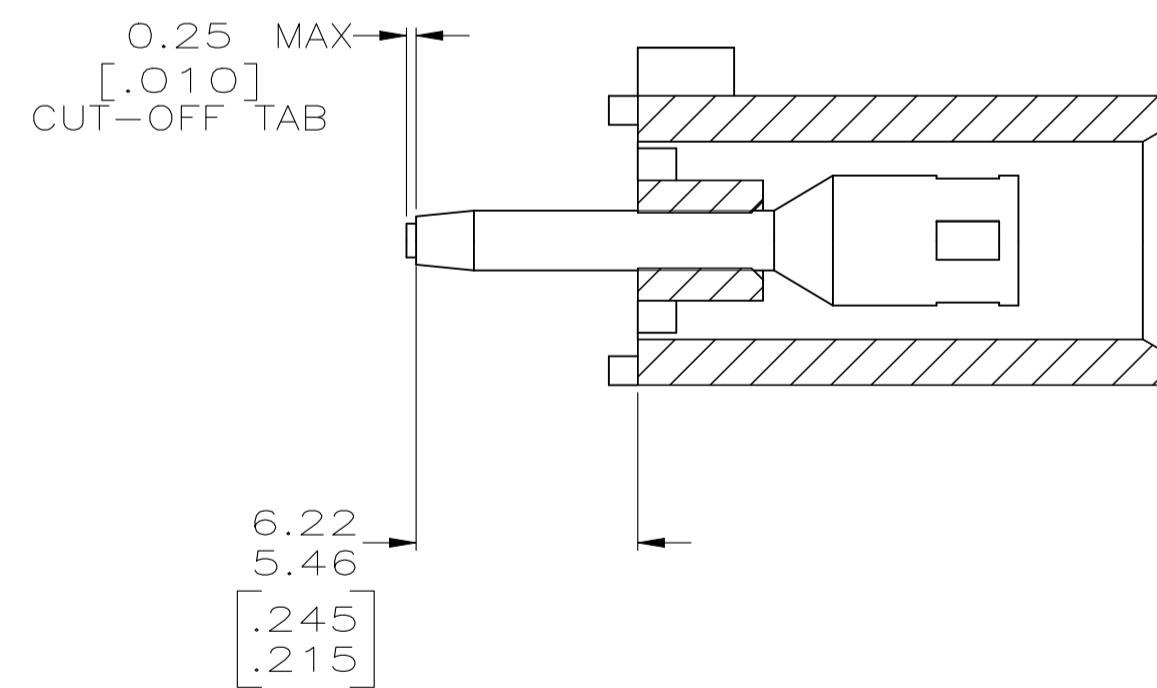
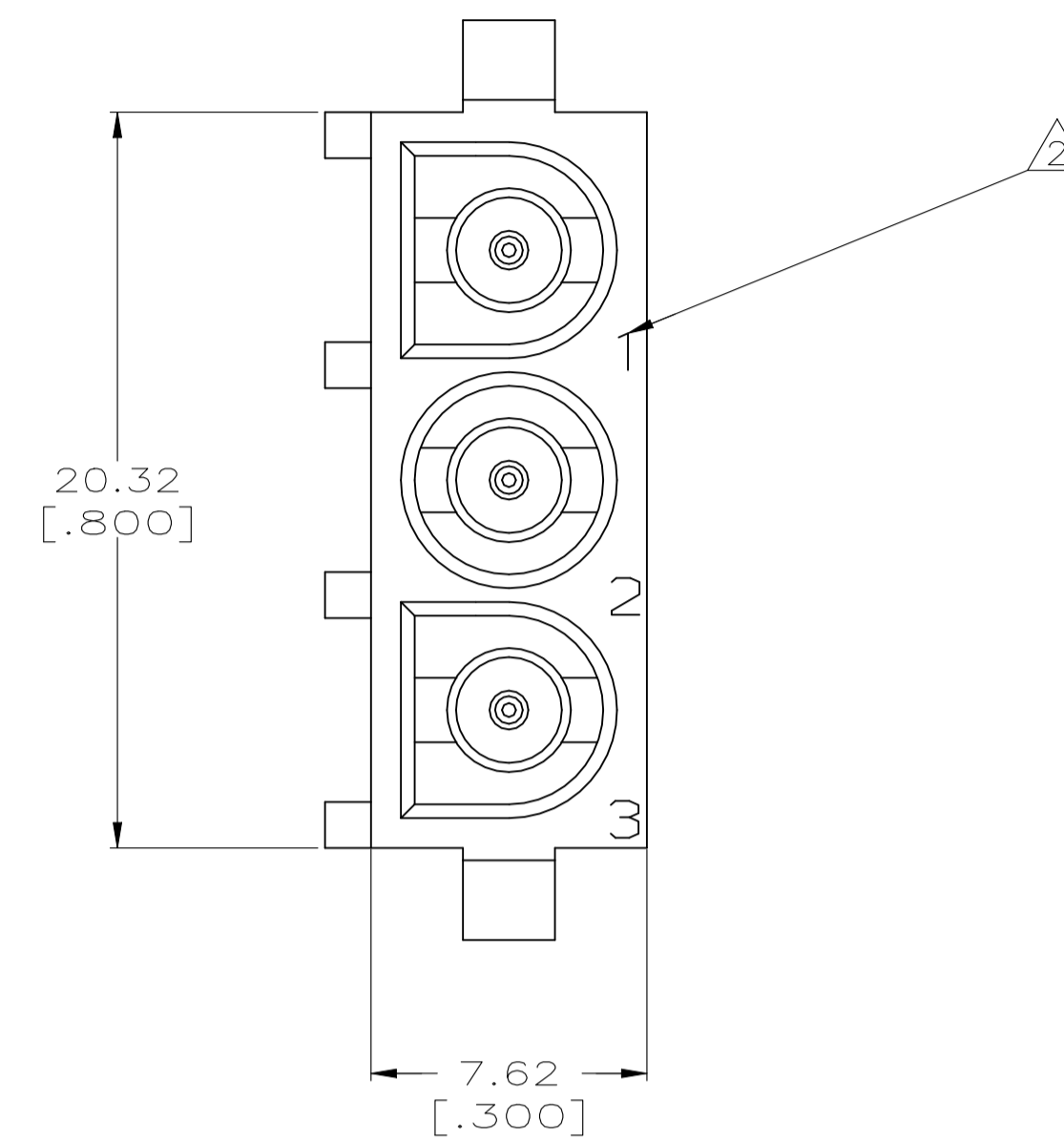
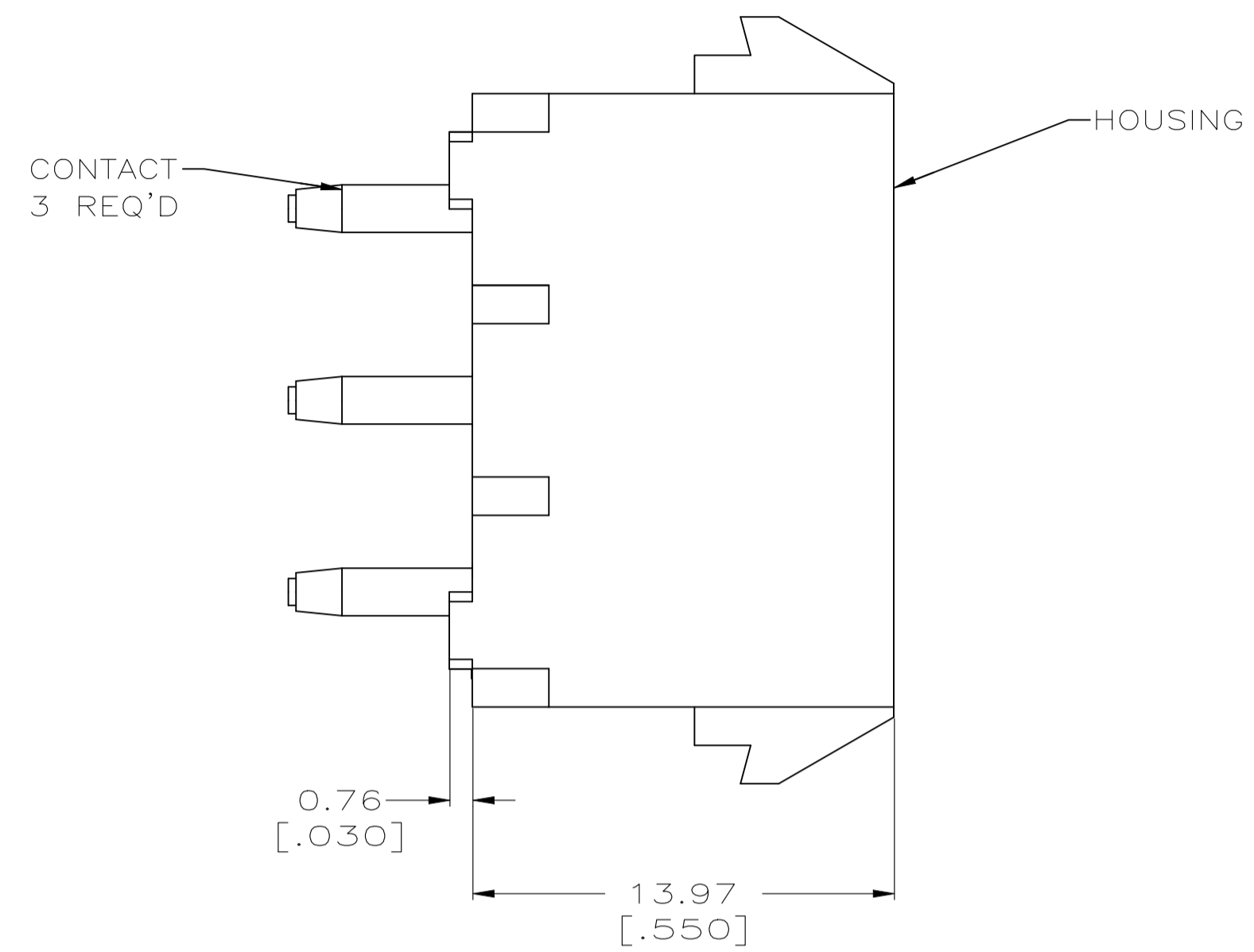
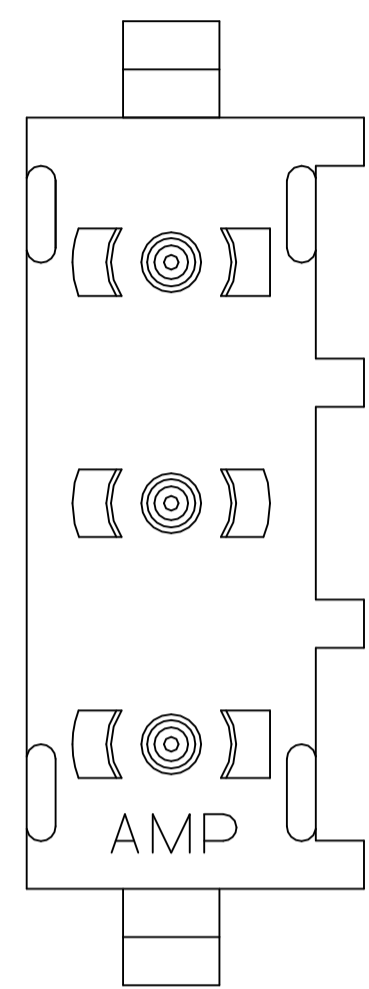
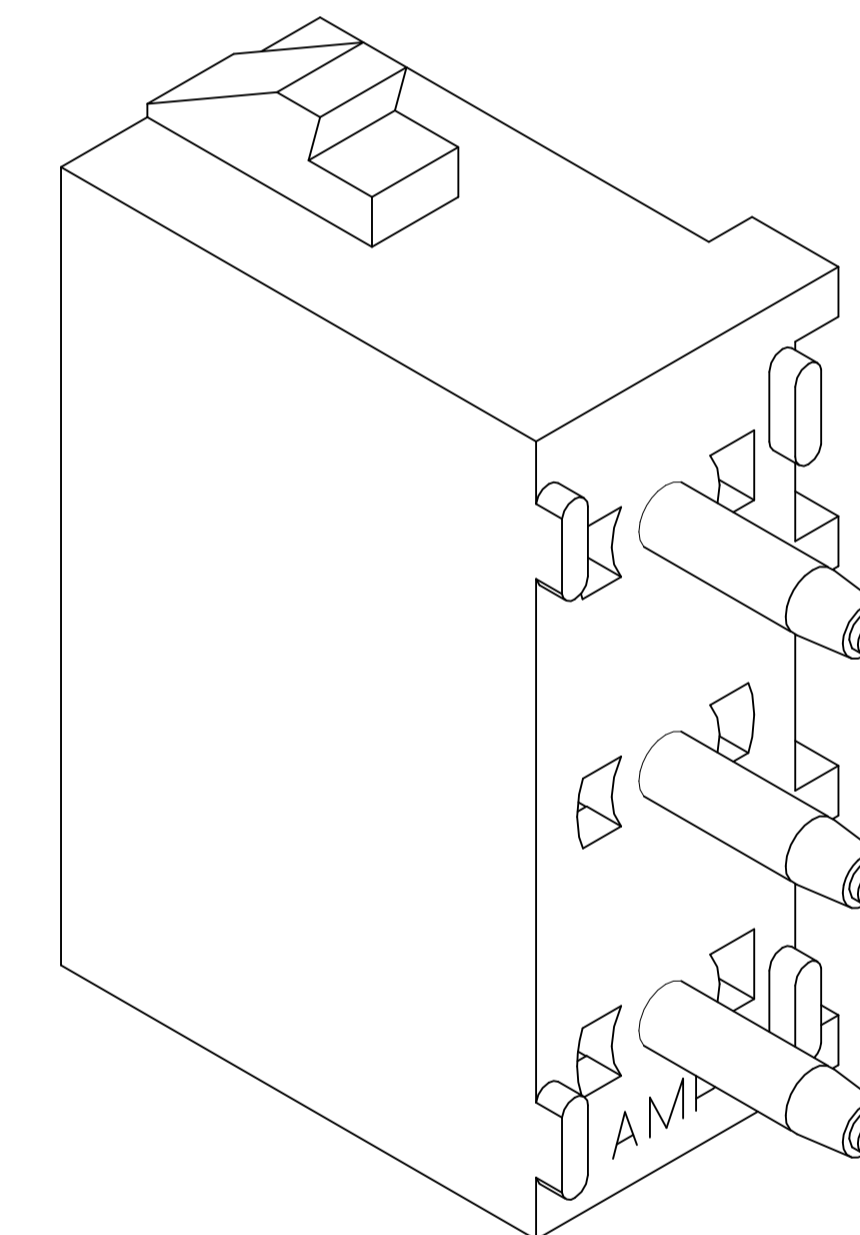

3-DIMENSIONAL MODEL NTS

PHOSPHOR BRONZE, PRE-TIN	NYLON, UL94V-2, NATURAL	350987-4
PIN CONTACT MATERIAL AND FINISH	HOUSING MATERIAL	PART NO
THIS DRAWING IS A CONTROLLED DOCUMENT.		DWN S. LEWIS 8-19-98
DIMENSIONS: mm (INCHES)		CHK R. SWING 8-19-98
TOLERANCES UNLESS OTHERWISE SPECIFIED:		APVD M. TRULL 8-19-98
0 PLC ±-	1 PLC ±-	NAME
2 PLC ±0.13 [.005]	3 PLC ±-	PRODUCT SPEC
4 PLC ±-	ANGLES ±0° '30'	APPLICATION SPEC
MATERIAL SEE TABLE	FINISH SEE TABLE	WEIGHT
CUSTOMER DRAWING		SCALE 5:1 SHEET 1 OF 1 REV H1



SOCKET HEADER ASSEMBLY, 3 CIRCUIT UNIVERSAL MATE-N-LOK™

SIZE A1 CAGE CODE 00779 DRAWING NO 350987

