

NEW

PC2 Series

CONNECTOR
 MB-0224-2
 April 2011

RoHS Compliant

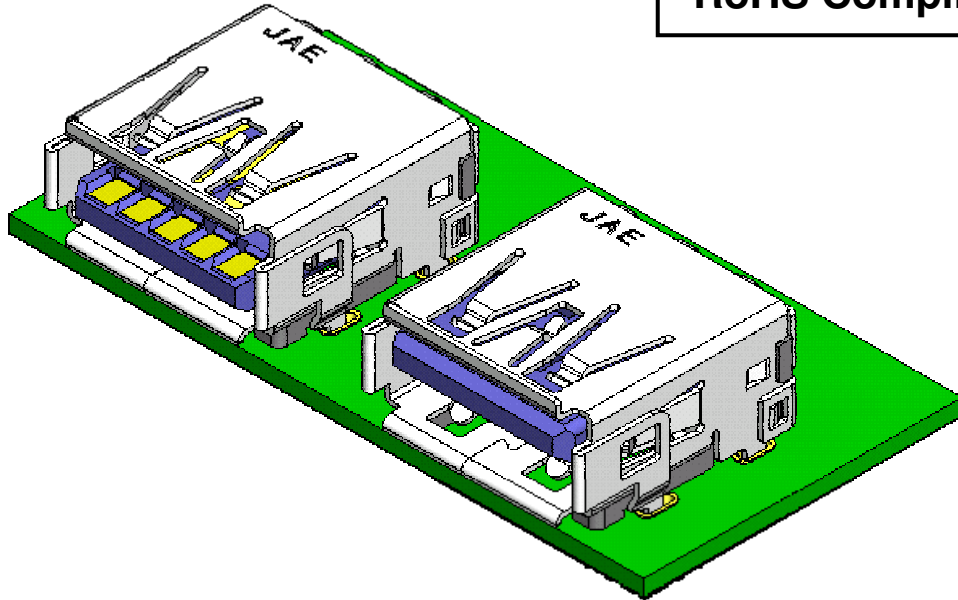

Features

JAE has developed the “PC2 Series” board-to-cable connectors, which are compatible with USB3.0 (USB Super Speed) standardized by the USB-IF(Note1). The PC2 Series connectors allow for greater board design freedom for customers by featuring a depth that is even smaller than the depth recommended in the standard (16mm). Also, the 4 hold-downs, twice as many as recommended in the standard, improve EMI characteristics and board soldering strength.

Note1) USB-IF: Universal Serial Bus-Implementers Forum

Applicable Markets: PCs, TVs, and consumer devices such as set top boxes.

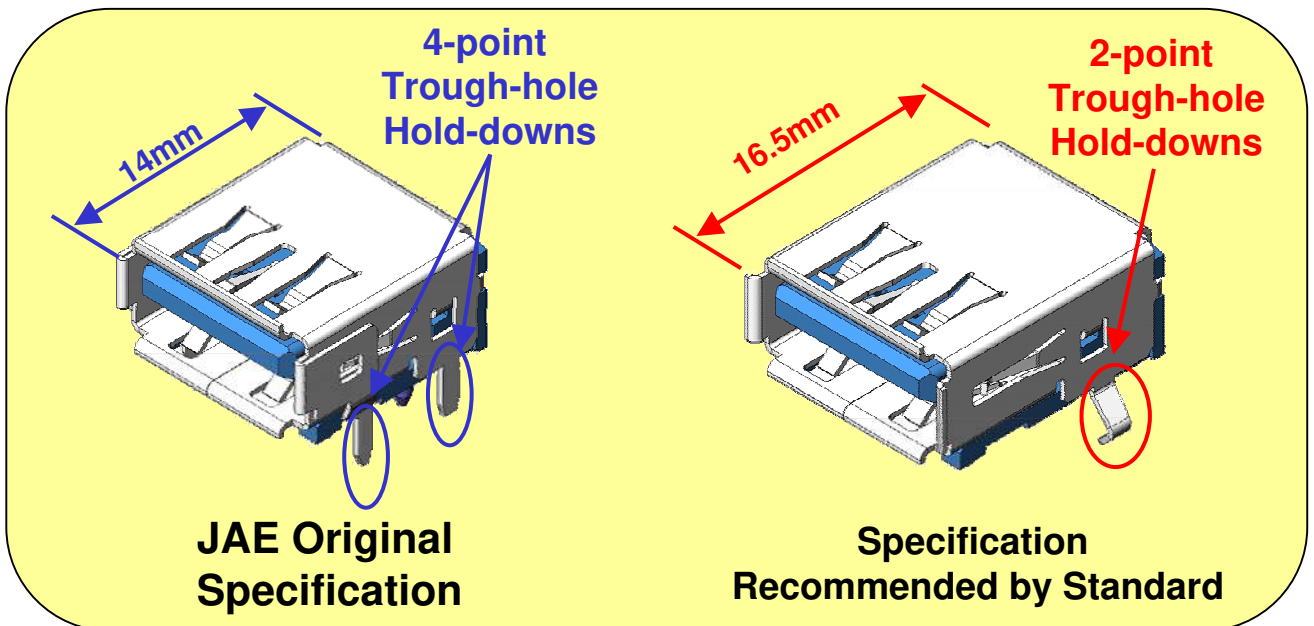

General Specifications

- No. of Contacts: 9 pos.
- Contact Resistance:
 Contacts for power --- 30mΩ max.
 Contacts for signal --- 50mΩ max.
- Dielectric Withstanding Voltage:
 AC500Vr.m.s per minute
- Rated Current:
 Contacts for power --- DC1.8A max. per terminal
 Contacts for signal --- DC0.25A max. per terminal
- Insulation Resistance: 100MΩ min. (after test)
- Operating Temperature: -20 Deg. C to +80 Deg. C

Materials and Finishes

Component	Material / Finish
Shell	Stainless Steel / Ni plating
Contact	Contact: Copper alloy /Contact area Au (0.05 μm Au) plating over Pd-Ni over Ni /Terminal area Sn plating over Ni
Insulator 1	Glass filled LCP
Insulator 2	Glass filled Nylon

Ordering Information

PC2 R L 1 S U 41 B 17 S *

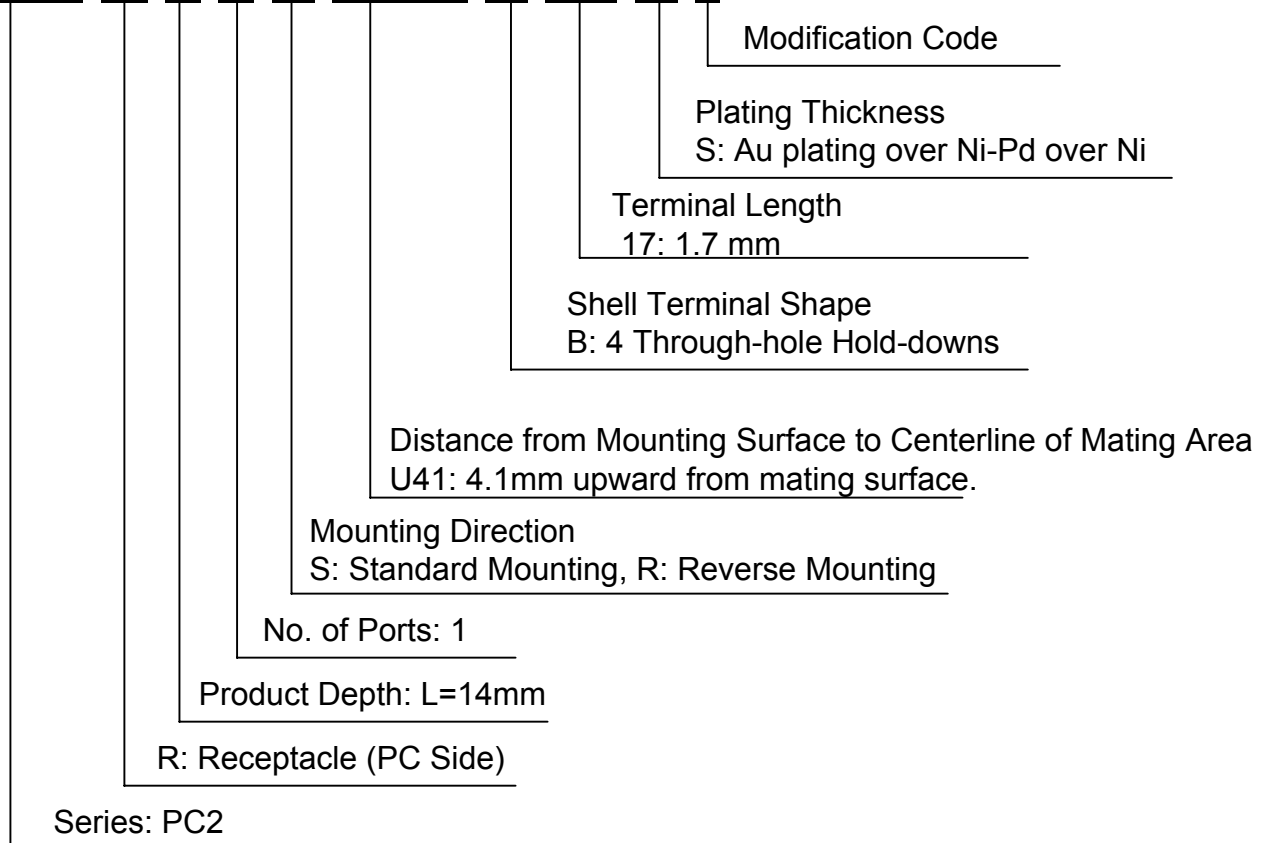

Product Drawing

■PC2RN1SU41B17S (Drawing of Individual Product)

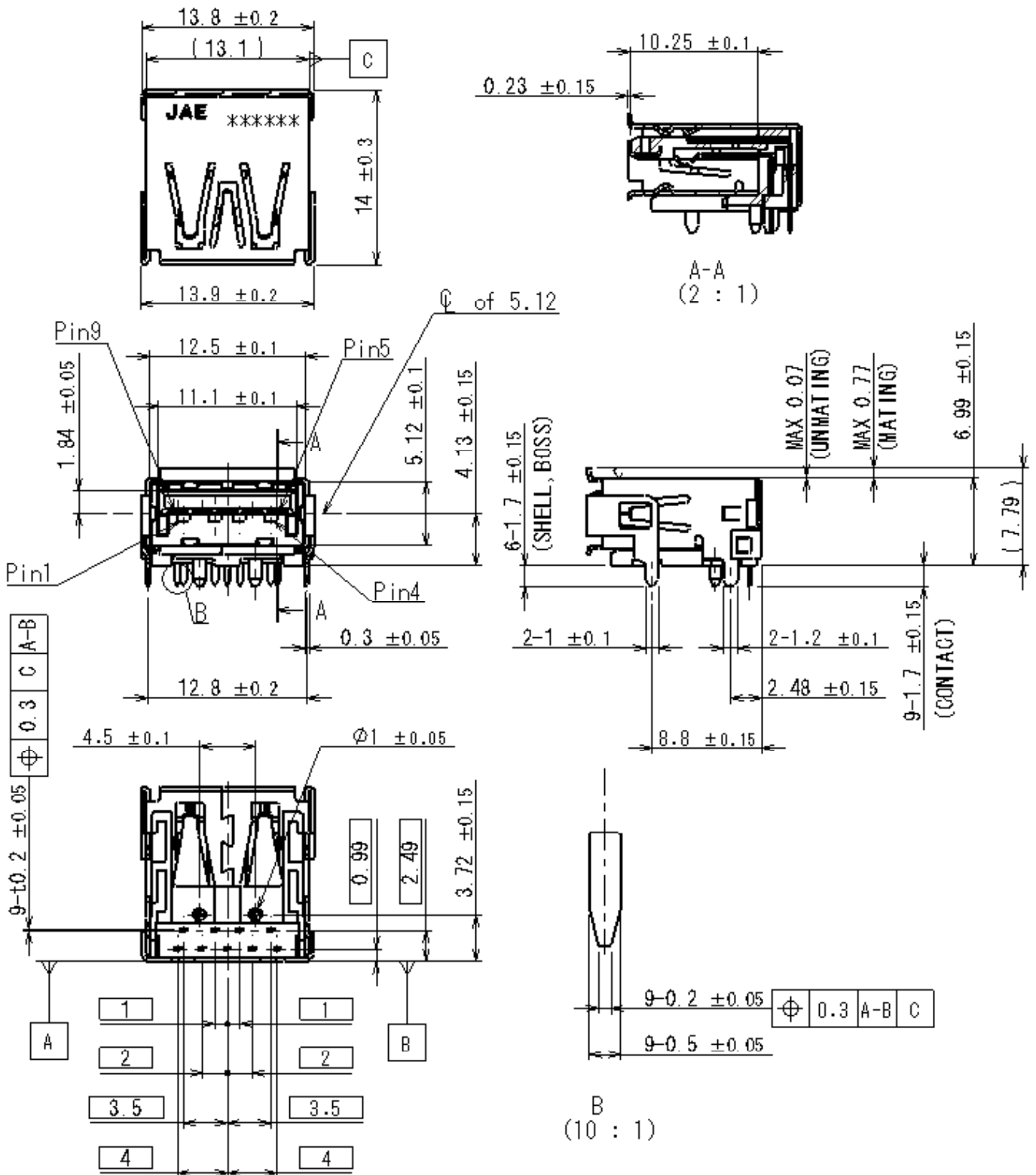

Product Drawing

■PC2RN1SU41B17S (Applicable Dimensions of Board)

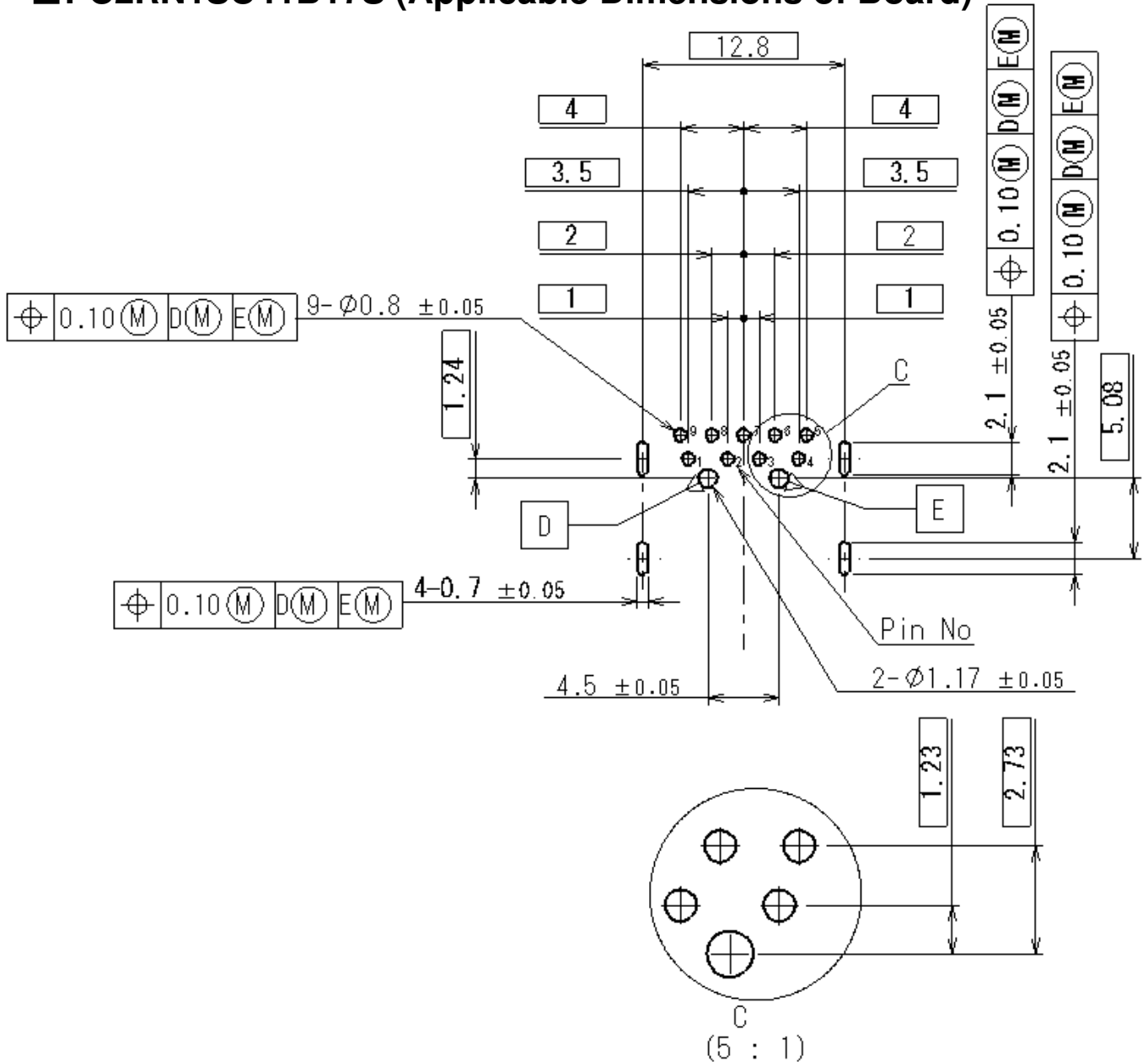

APPLICABLE P.C.B DIMENSION (REF.)

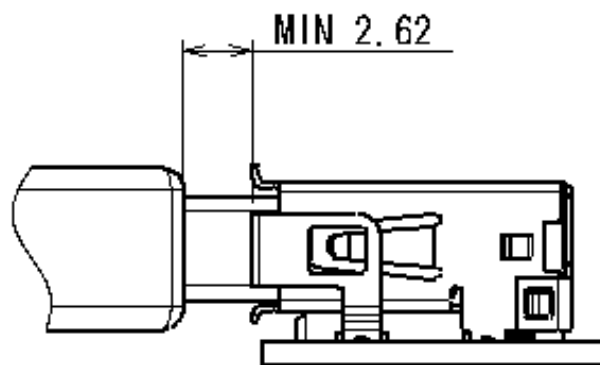

MATED CONDITION (REF.)

Product Drawing

■PC2RN1SU41B17S (Drawing of Packaging)

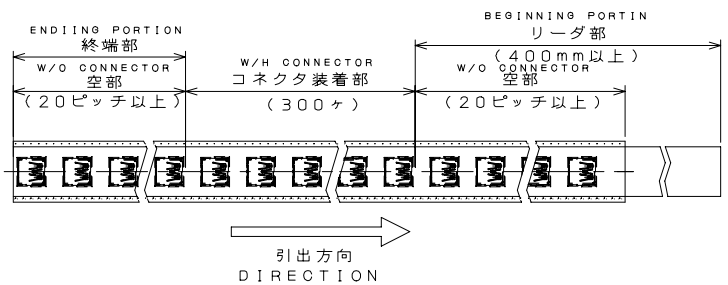
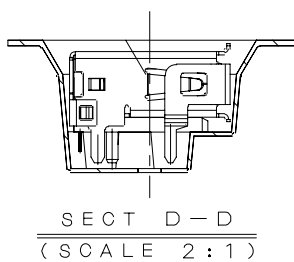
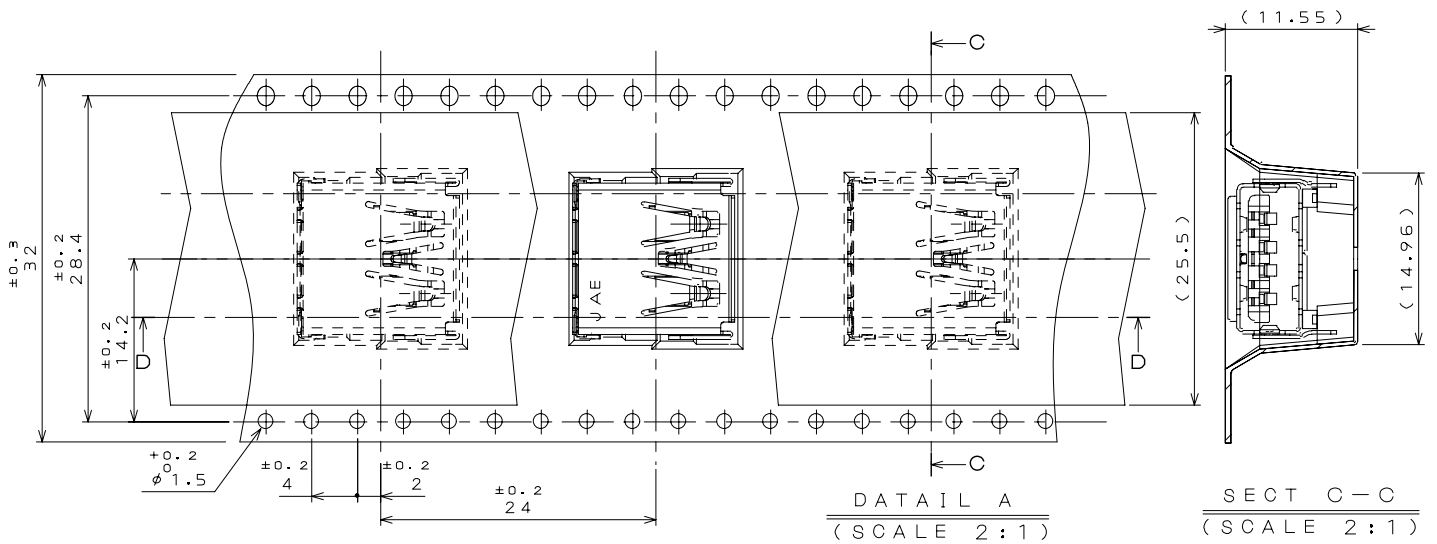
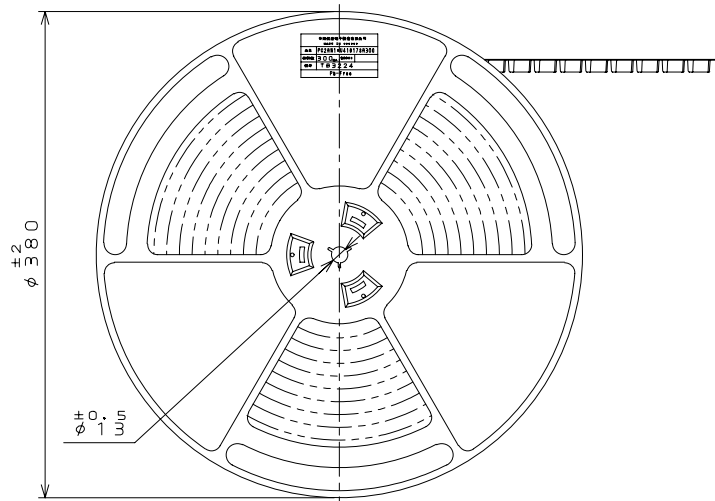
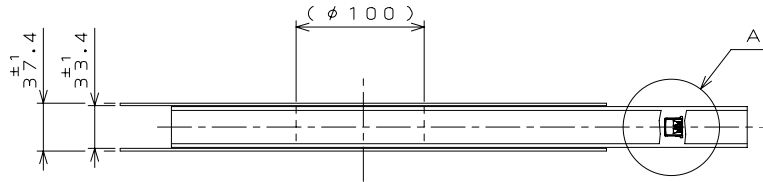

Product Drawing

■ PC2RN1RU41B17S (Drawing of Individual Product)

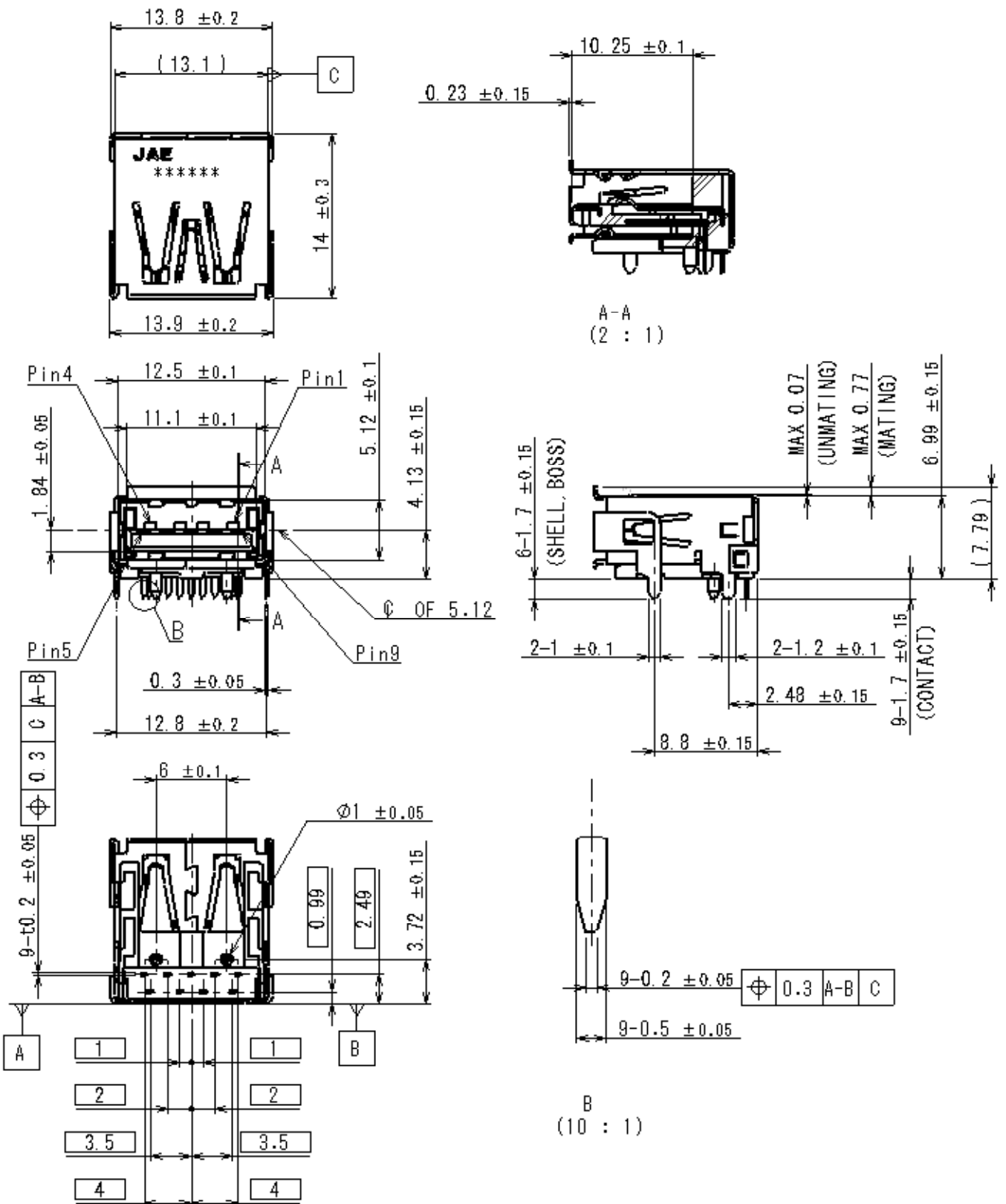

Product Drawing

■ PC2RN1RU41B17S (Applicable Dimensions of Board)

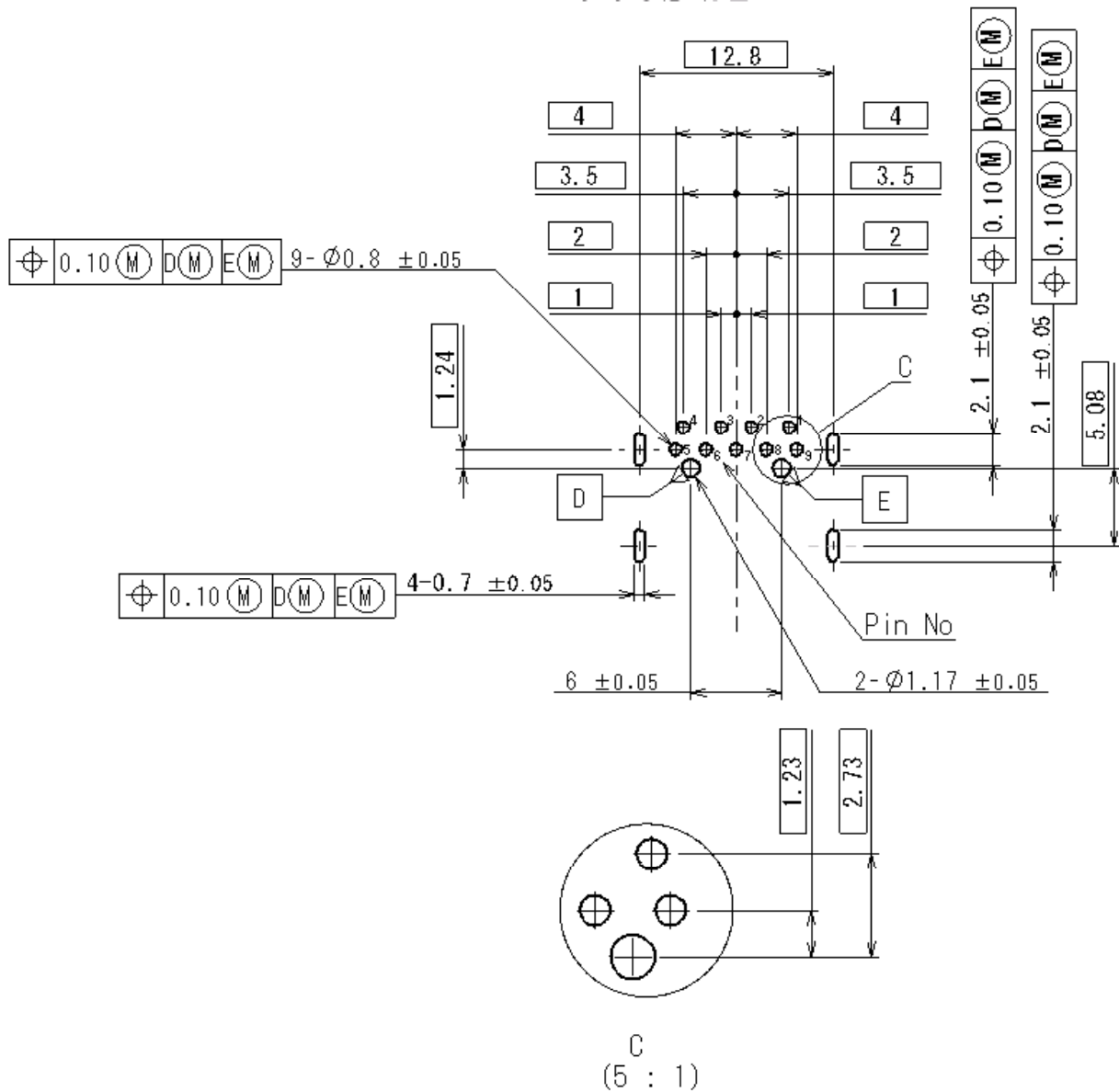

APPLICABLE P.C.B DIMENSION (REF.)

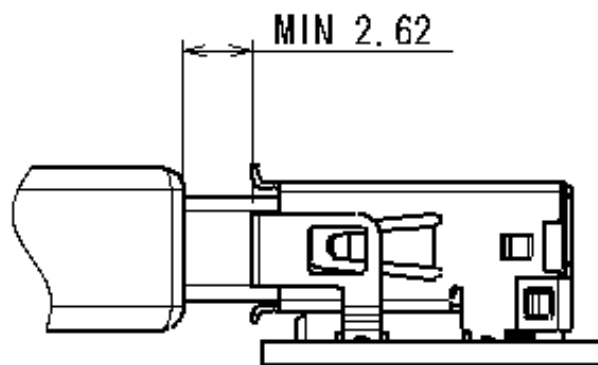

MATED CONDITION (REF.)

Product Drawing

■PC2RN1RU41B17S (Drawing of Packaging)

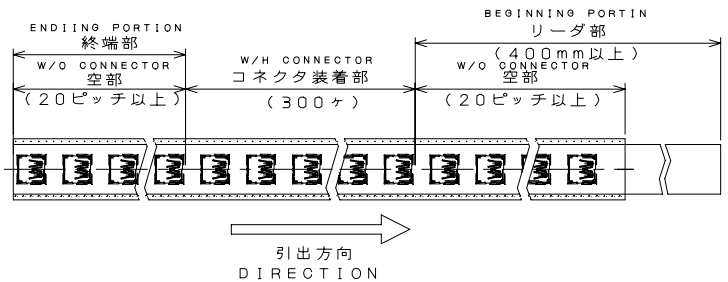
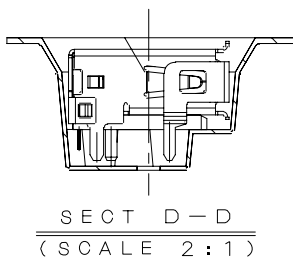
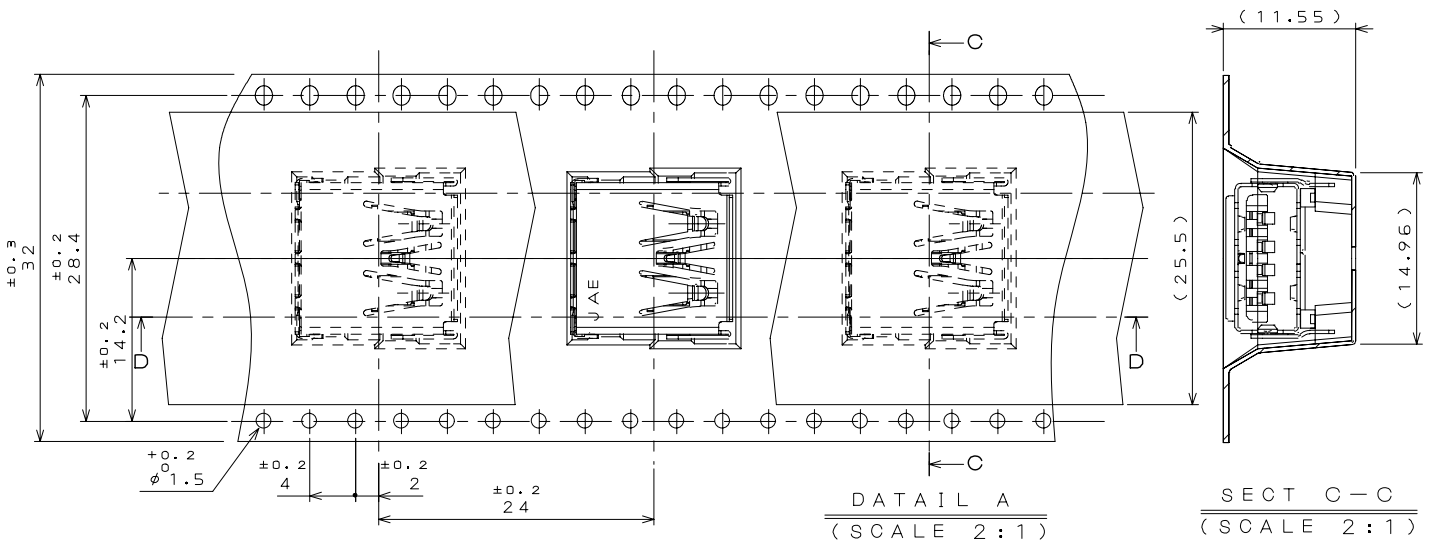
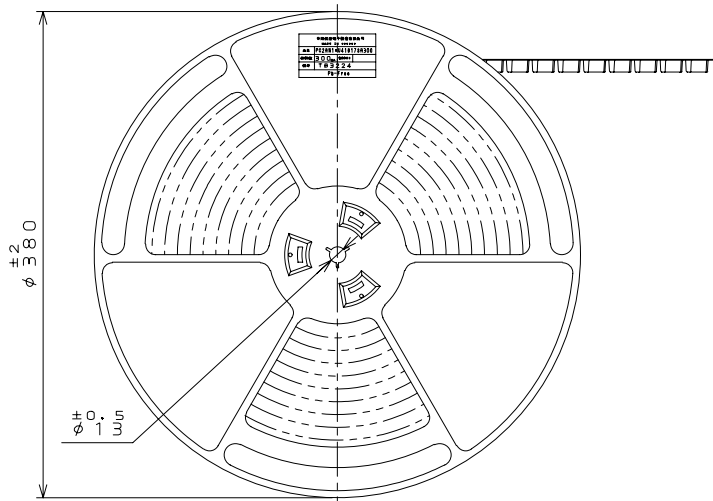
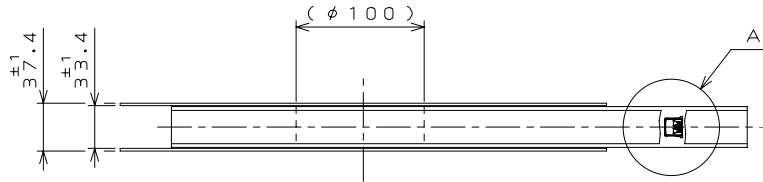

Product Drawing

■ PC2RN1SU41B09S1 (Drawing of Individual Product)

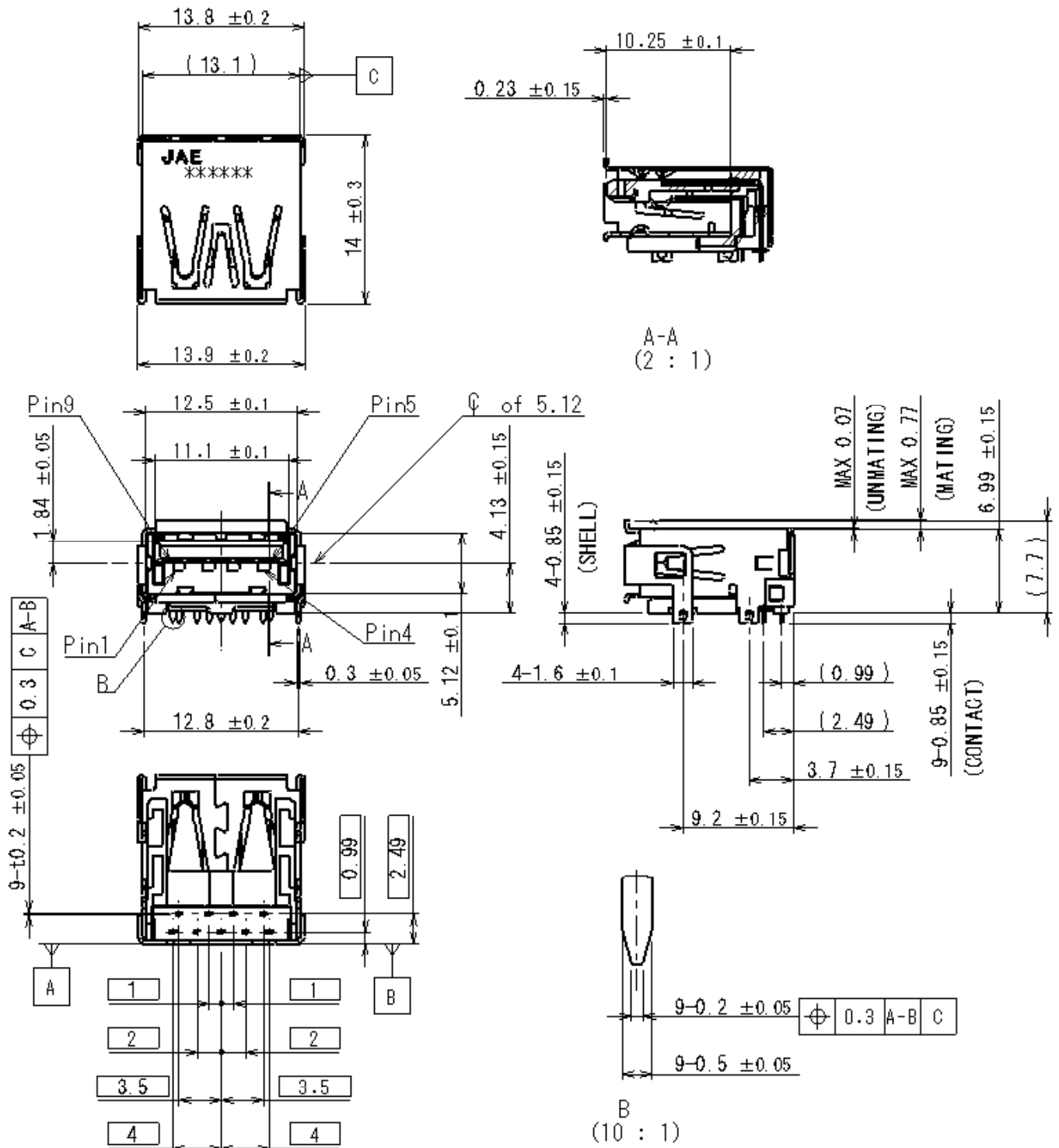

Product Drawing

■ PC2RN1SU41B09S1 (Applicable Dimensions of Board)

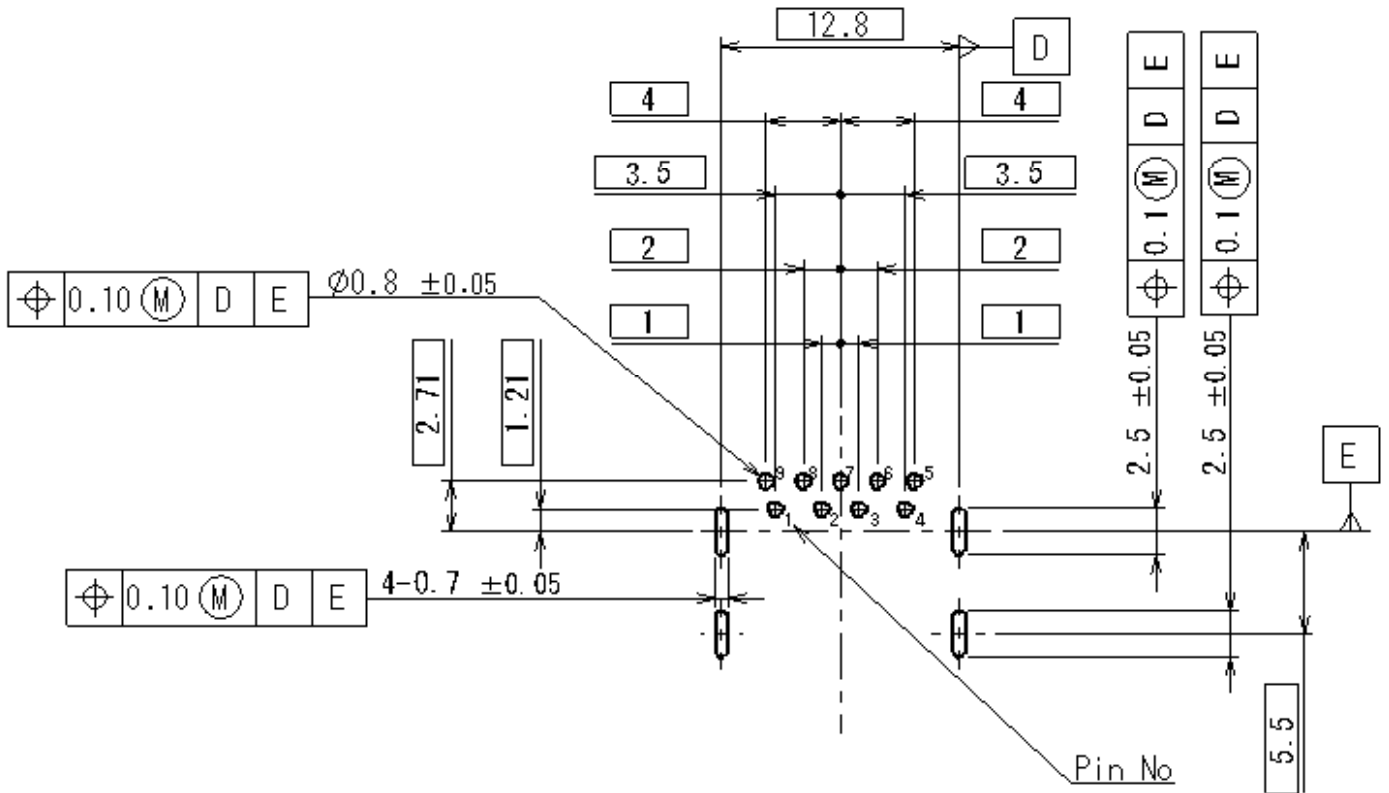

APPLICABLE P.C.B DIMENSION (REF.)

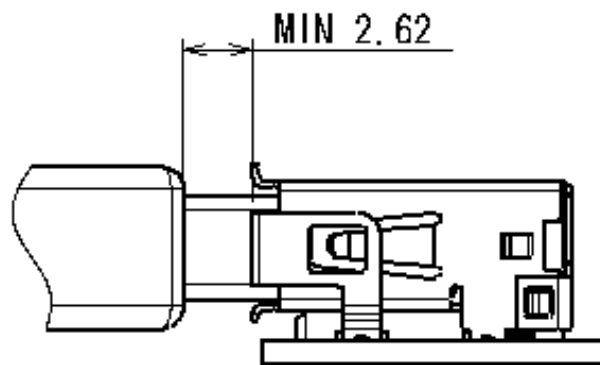

MATED CONDITION (REF.)

Product Drawing

■ PC2RN1SU41B09S1 (Drawing of Packaging)

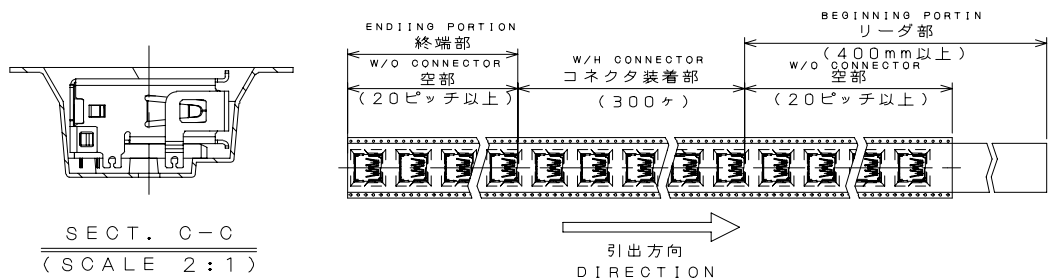
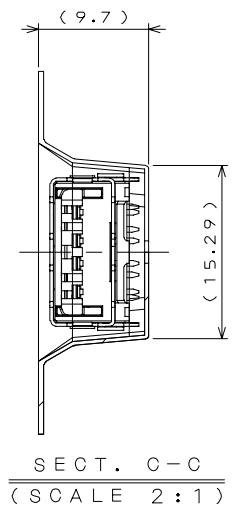
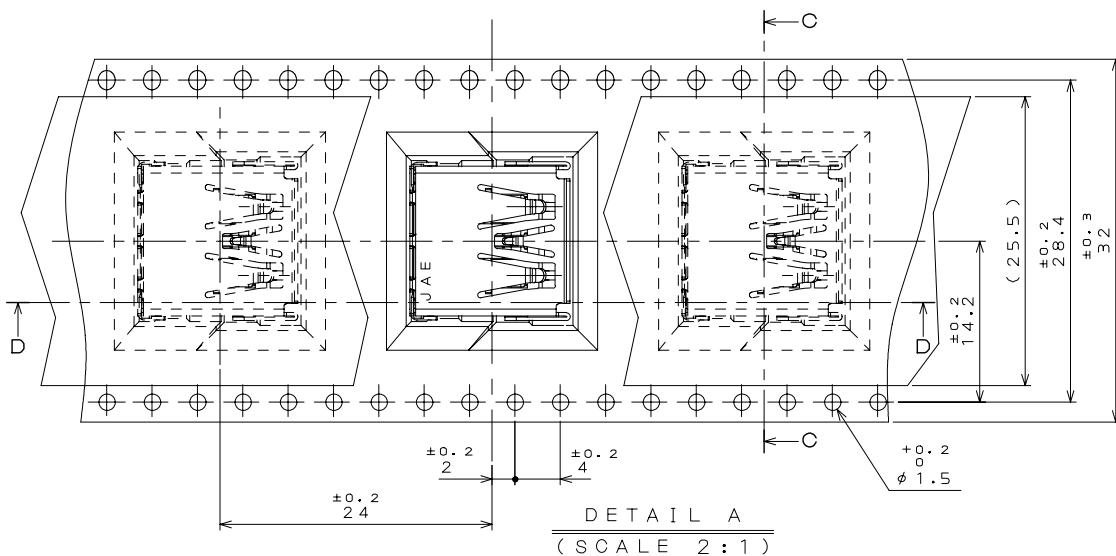
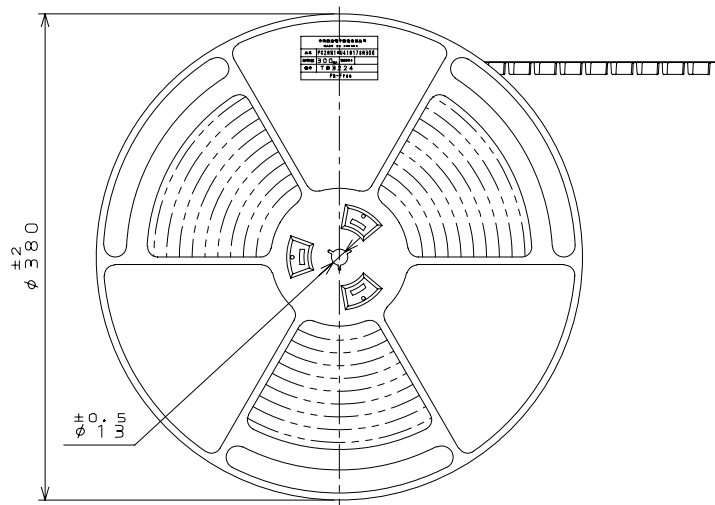
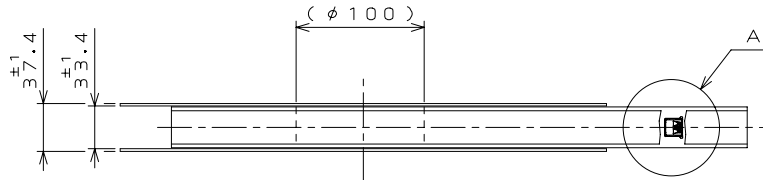

Product Drawing

■ PC2RN1RU41B09S1 (Drawing of Individual Product)

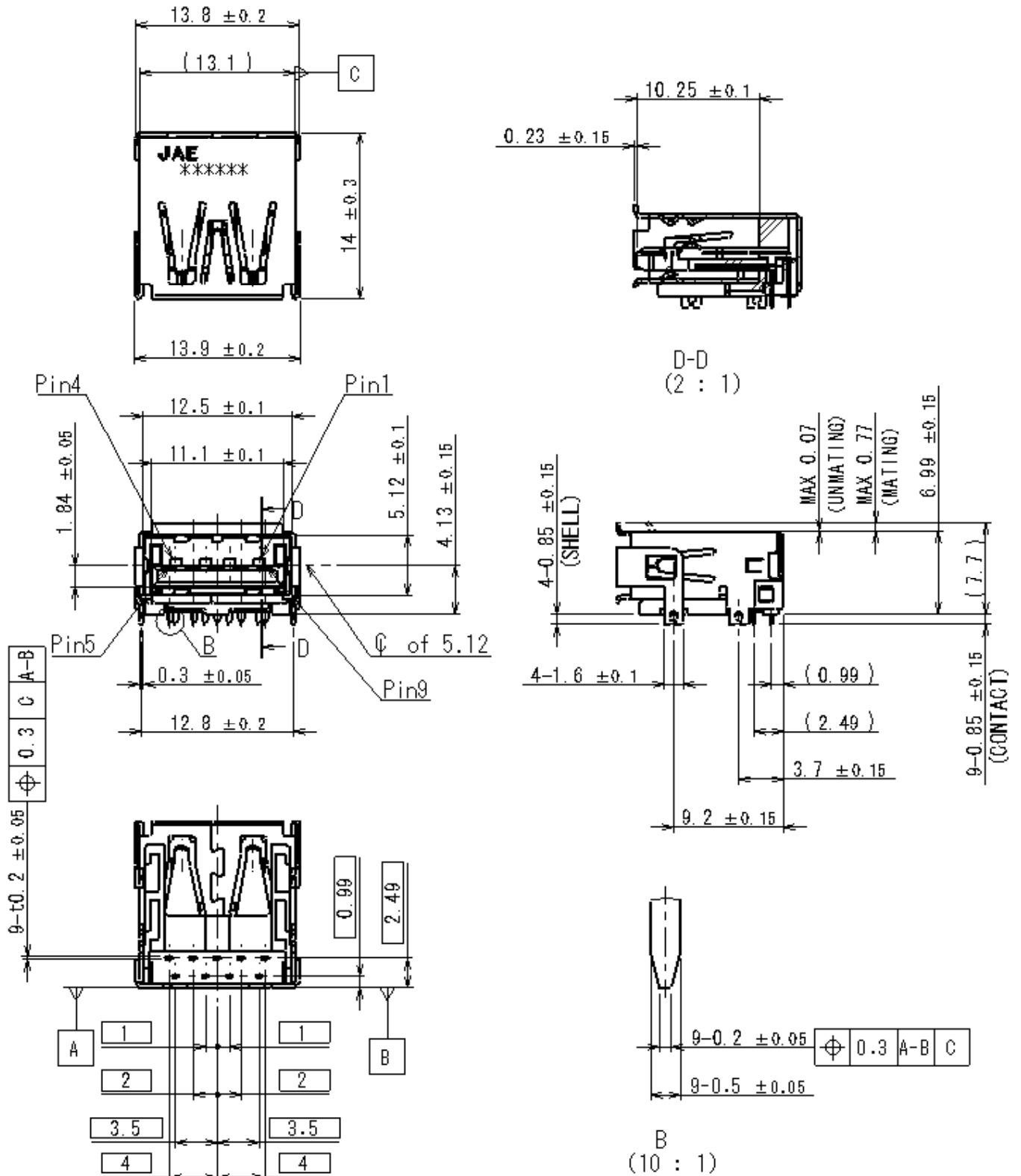

Product Drawing

■ PC2RN1RU41B09S1 (Applicable Dimensions of Board)

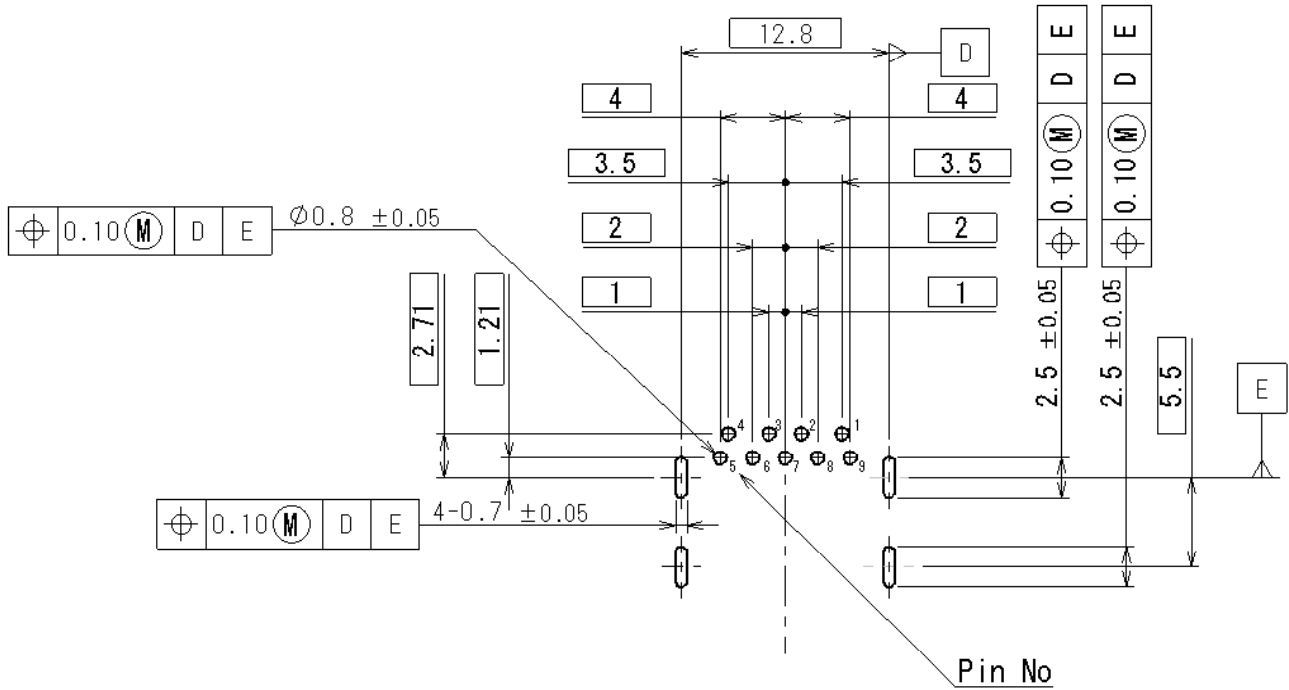

APPLICABLE P.C.B DIMENSION (REF.)

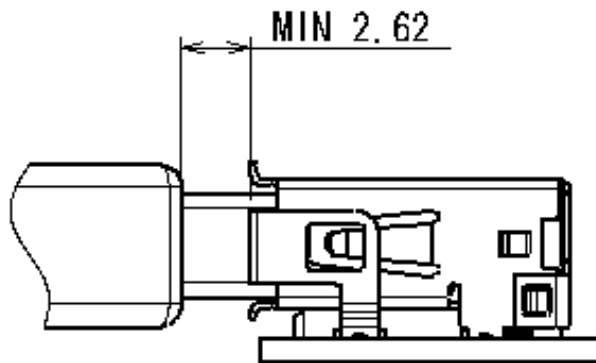



MATED CONDITION (REF.)

Product Drawing

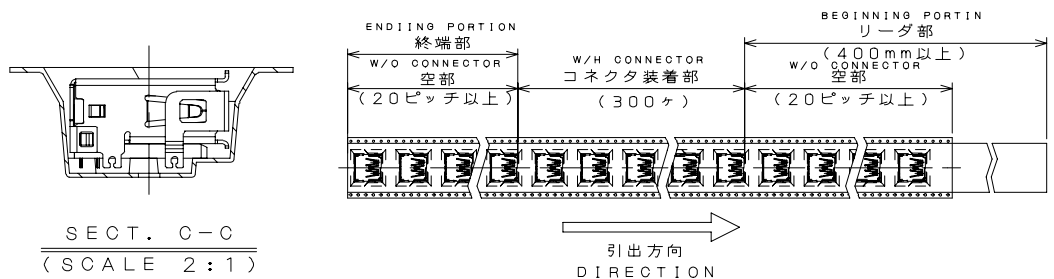
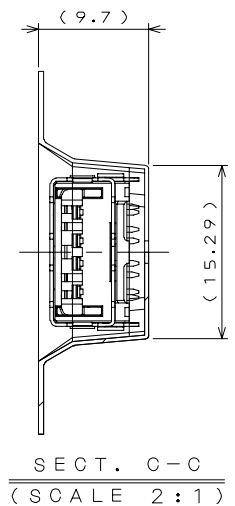
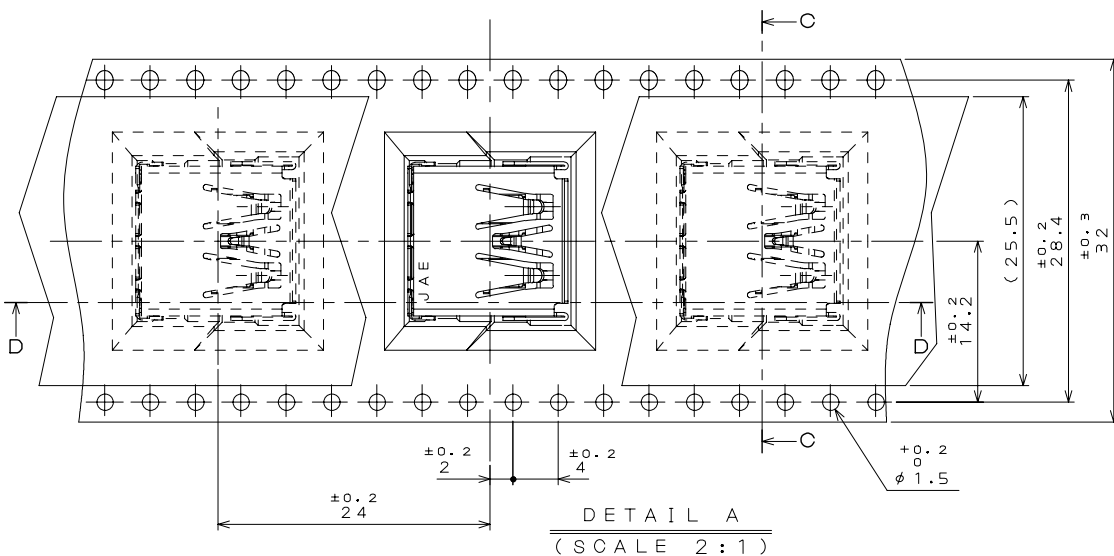
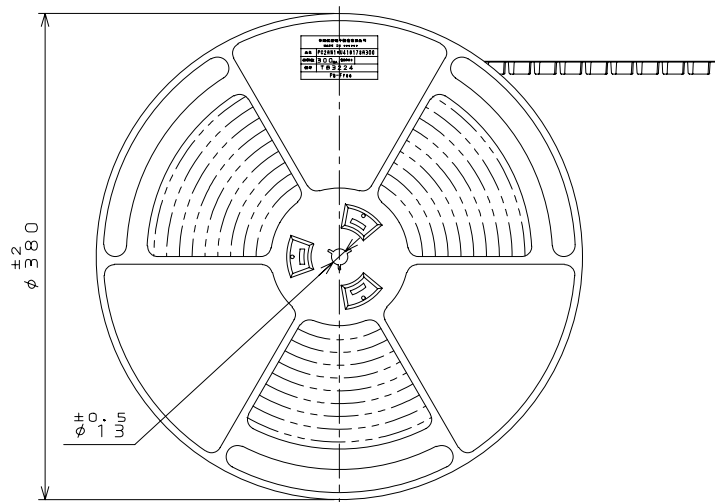
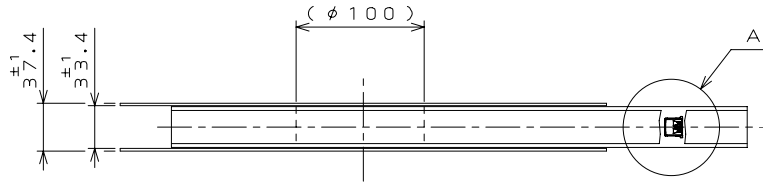
■ PC2RN1RU41B09S1 (Drawing of Packaging)

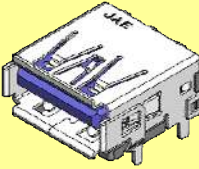
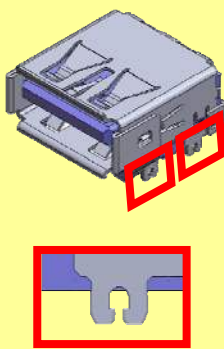
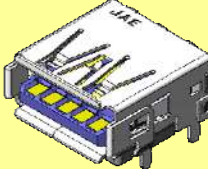
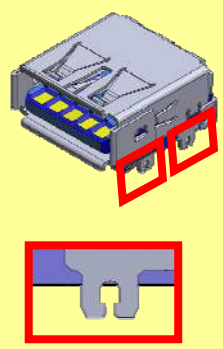

Drawing Number

Part Number	PC2RN1SU4 1B17S	PC2RN1SU41B 09S1	PC2RN1RU41 B17S	PC2RN1RU41 B09S1	USB-IF Standard Connector
Drawing of Individual Product	SJ111080	SJ111081	SJ111078	SJ111079	
Drawing of Packaging	SJ111181	SJ111182	SJ111181	SJ111182	
Specification	JACS-30147				
		 Fork Type		 Fork Type	
Mounting Type	On-board				On-board
Mating Direction	Standard		Reverse		Standard
Boss	With Boss	Without Boss	With Boss	Without Boss	Standard
Terminal Length	1.7mm	0.85mm	1.7mm	0.85mm	N/A
Front Side Shell Terminal Shape	Through-hole (Straight)	Through-hole (Fork)	Through-hole (Straight)	Through-hole (Fork)	N/A
Back Side Shell Terminal Shape	Through-hole (Straight)	Through-hole (Fork)	Through-hole (Straight)	Through-hole (Fork)	Kink
Product Depth	14mm	14mm	14mm	14mm	16mm

Notice: Products shown in this brochure are made for the applications listed below. However, if the above-mentioned products are to be used in aerospace devices, marine cable-connection devices, atomic power control systems, medical equipment for life-support systems, or any other specific application requiring extremely high reliability, please contact JAE for further information.
Recommended applications: Computers, Office machines, Measuring devices, Telecommunication devices (Terminals, Mobile devices), AV devices, Household applications, FA devices, etc.

Japan Aviation Electronics Industry, Limited

Product Marketing Division
Aobadai Building, 3-1-19, Aobadai, Meguro-ku, Tokyo 153-8539
Phone: +81-3-3780-2787 FAX: +81-3-3780-2946