

Type N Right Angle Plug Crimp Style for RG-213 and 214 Flexible Cable

1. Identify connector parts. (3 piece parts)
2. Strip cable to dimensions shown. Do not nick center conductor. A wire stripper of correct size is recommended for this step. Slide crimp sleeve onto jacket of cable.
3. Flare braid and slide plug connector assembly over cable dielectric and under braid. Make sure center conductor is contained within plug contact as shown. Center conductor should not protrude above slots in plug contact and cable dielectric should not touch plug contact. Solder center conductor to plug contact through rear access port. Use a minimum amount of solder for a full fillet joint.
4. Arrange braid uniformly around crimp stem. Slide crimp sleeve forward and crimp using Johnson ergonomic hand crimp frame 140-0000-967 with recommended hex size die set. Screw end cap into access port.

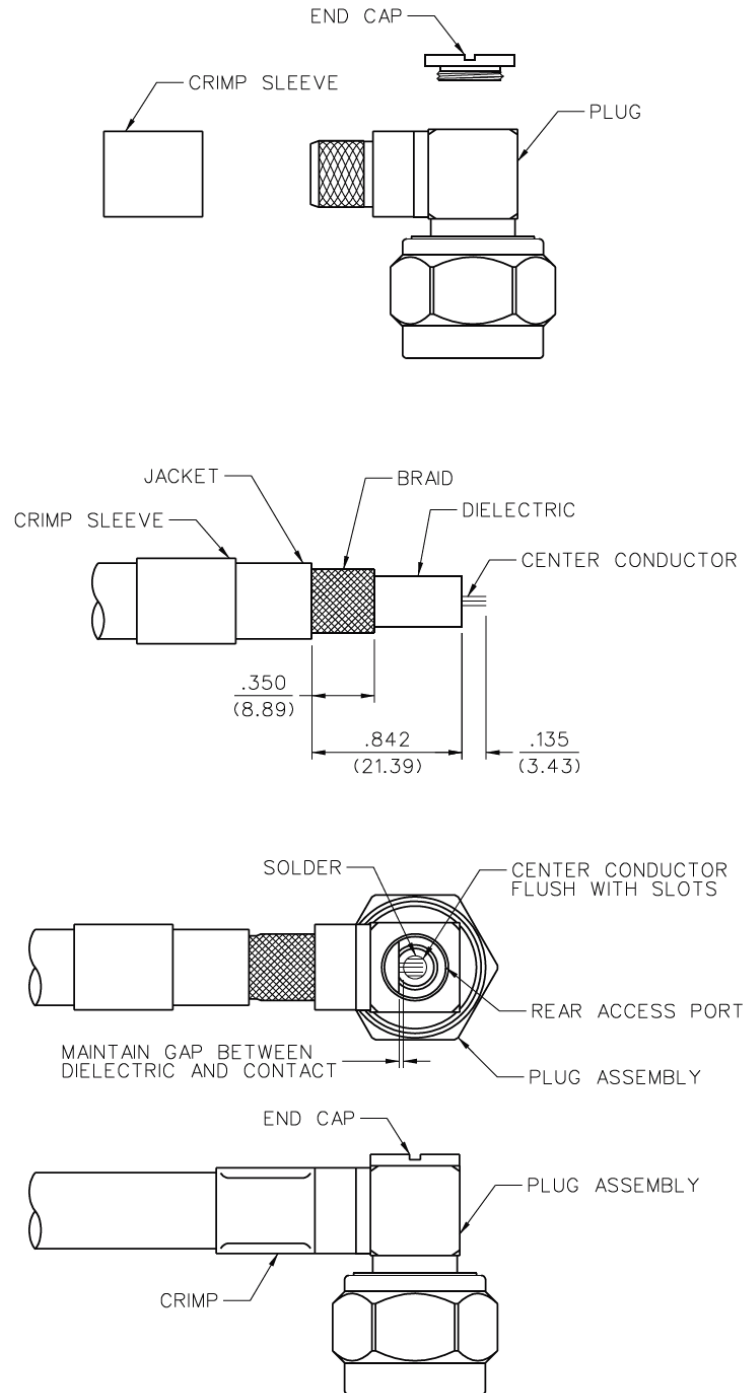

| Cable Group | Part No. | Contact Crimp |
|-------------|--------------|---------------|
| RG-8, 213 | 138-4416-107 | .429 (10.90) |
| RG-9, 214 | 138-4418-107 | .429 (10.90) |

| Assembly | |
|-------------|-------------------|
| Tool | 138-4416/4418-107 |
| Crimp Frame | 140-0000-967 |
| Die Set | 140-0000-991 |