

DO NOT SCALE FROM THIS PRINT

TABLE 1			
No. OF POS	"A"	"B"	"C"
-10	5.25 [0.207]	4.500 [0.1772]	6.40 [0.252]
-15	7.75 [0.305]	7.000 [0.2756]	8.90 [0.350]
-20	10.25 [0.404]	9.500 [0.3740]	11.40 [0.449]
-30	15.25 [0.600]	14.500 [0.5709]	16.40 [0.646]
-40	20.25 [0.797]	19.500 [0.7677]	21.40 [0.843]
-50	25.25 [0.994]	24.500 [0.9646]	26.40 [1.039]
-60	30.25 [1.191]	29.500 [1.1614]	31.40 [1.236]
-70	35.25 [1.388]	34.500 [1.3583]	36.40 [1.433]
-80	40.25 [1.585]	39.500 [1.5551]	41.40 [1.630]

DESIGNED & DIMENSIONED IN MILLIMETERS [INCHES]

ST5-XX-X.XX-X-D-P-TR

No. OF POSITIONS  
-10, -15, -20, -30, -40,  
-50, -60, -70, -80 (PER ROW)

PACKAGING  
-TR: TAPE AND REEL  
(SEE NOTES 3)

LEAD STYLE  
-1.00: (USE T-1M50-1.00-L)  
-1.50: (USE T-1M50-1.50-L)  
\*-2.50: (USE T-1M50-2.50-L)

PLACEMENT PAD  
-P: PICK AND PLACE PAD  
(SEE FIG 4, SHT 2)  
(-10, -20, -30, -40, -50, -60, -70, -80  
USE PPP-65-01, -15 USE PPP-65-02)

PLATING SPECIFICATION  
-L: 10µ" SELECTIVE GOLD IN CONTACT AREA, MATTE TIN ON TAIL

ROW SPECIFICATION  
-D: DOUBLE

(\* = NOT TOOLED)

TABLE 2 REF		
STACK HEIGHT		
ST5 LEAD STYLE	SS5 LEAD STYLE	
	-3.00	-3.50
-1.00	4.0 [0.16]	4.5 [0.18]
-1.50	4.5 [0.18]	5.0 [0.20]
*-2.50	5.5 [0.22]	6.0 [0.24]

(\* = NOT TOOLED)

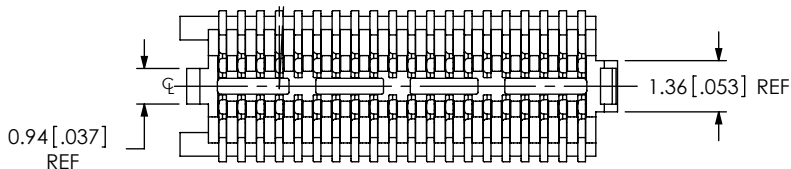
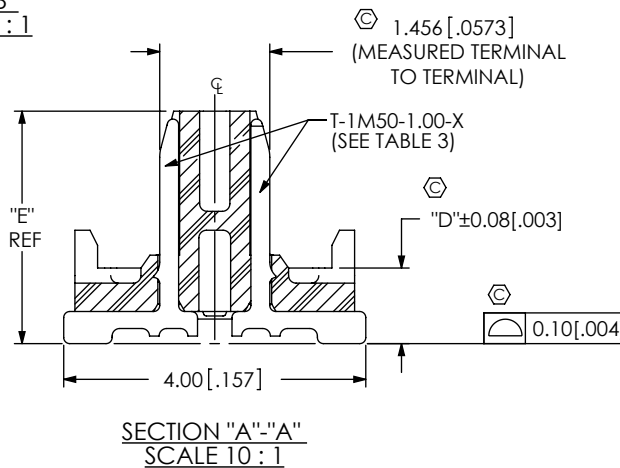
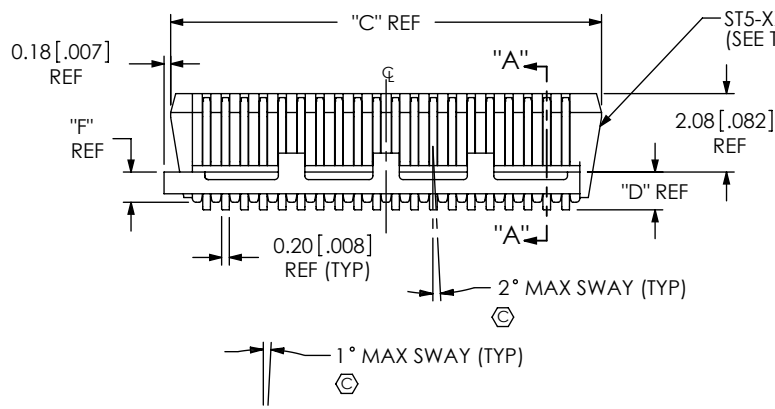
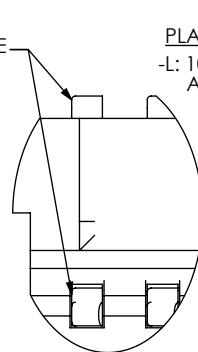
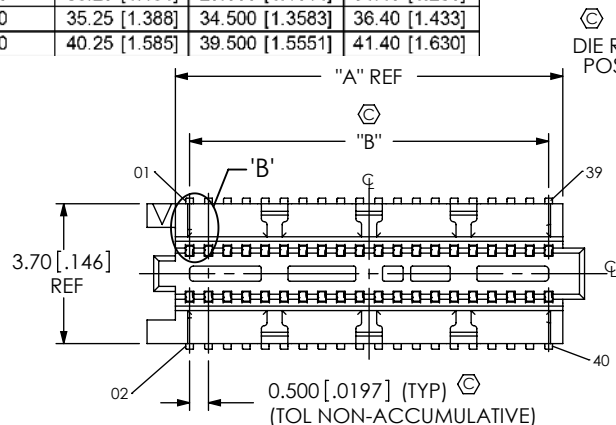

TABLE 3					
LEAD STYLE	"D"	"E"	"F"	BODY	TERMINAL
-1.00	1.00 [0.039]	3.08 [0.121]	0.80 [0.031]	ST5-XX-1.00-D	T-1M50-1.00-X
-1.50	1.50 [0.059]	3.58 [0.141]	0.80 [0.031]	ST5-XX-1.00-D	T-1M50-1.50-X
*-2.50	2.50 [0.098]	4.58 [0.180]	1.80 [0.071]	ST5-XX-2.50-D	T-1M50-2.50-X

(\* = NOT TOOLED)

FIG 1  
ST5-20-1.00-X-D-P-TR SHOWN

NOTES:

1. Ⓢ REPRESENTS A CRITICAL DIMENSION.
2. MINIMUM PUSHOUT FORCE: SIGNAL: 1.11N [0.25 LB].
3. FOR QUANTITIES UP TO 49 PIECES, NO LEADER, TRAILER, OR REEL WILL BE SUPPLIED. FOR QUANTITIES OF 50-124 PIECES, NO LEADER OR TRAILER WILL BE SUPPLIED.

UNLESS OTHERWISE SPECIFIED, DIMENSIONS ARE IN MILLIMETERS. TOLERANCES ARE:  
DECIMALS ANGLES  
X.X: ±0.3 [0.1] 2°  
X.XX: ±0.13 [0.05]  
X.XXX: ±0.051 [0.020]

PROPRIETARY NOTE  
THIS DOCUMENT CONTAINS CONFIDENTIAL AND PROPRIETARY INFORMATION AND ALL DESIGN, MANUFACTURING, REPRODUCTION, USE, PATENT RIGHTS AND SALES RIGHTS ARE EXPRESSLY RESERVED BY SAMTEC, INC. THIS DOCUMENT SHALL NOT BE DISCLOSED, IN WHOLE OR PART, TO ANY UNAUTHORIZED PERSON OR ENTITY NOR REPRODUCED, TRANSFERRED OR INCORPORATED IN ANY OTHER PROJECT IN ANY MANNER WITHOUT THE EXPRESS WRITTEN CONSENT OF SAMTEC, INC.



520 PARK EAST BLVD, NEW ALBANY, IN 47150  
PHONE: 812-944-6733 FAX: 812-948-5047  
e-Mail: info@SAMTEC.com code: 53322

MATERIAL: DO NOT SCALE DRAWING SHEET SCALE: 2:1  
INSULATOR: LCP, UL 94 V0, COLOR: BLACK  
TERMINAL: PHOS BRONZE

DESCRIPTION:  
0.5mm TERMINAL STRIP ASSEMBLY

DWG. NO.  
ST5-XX-X.XX-X-D-P-TR

BY: ROY LUO 03/29/2012 SHEET 1 OF 2

**FIG 2**  
-1.50 LEAD STYLE  
ST5-20-1.50-X-D-P-TR SHOWN  
(DIFFERENT AS SHOWN, OTHERWISE SAME AS FIG 1)

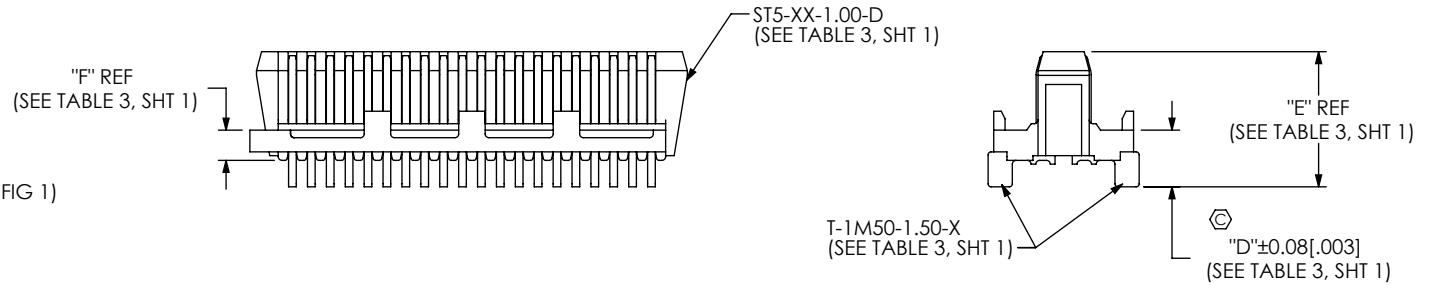

**FIG 3**  
\* -2.50 LEAD STYLE  
ST5-20-2.50-X-D-P-TR SHOWN  
(DIFFERENT AS SHOWN, OTHERWISE SAME AS FIG 1)  
(\* = NOT TOOLED)

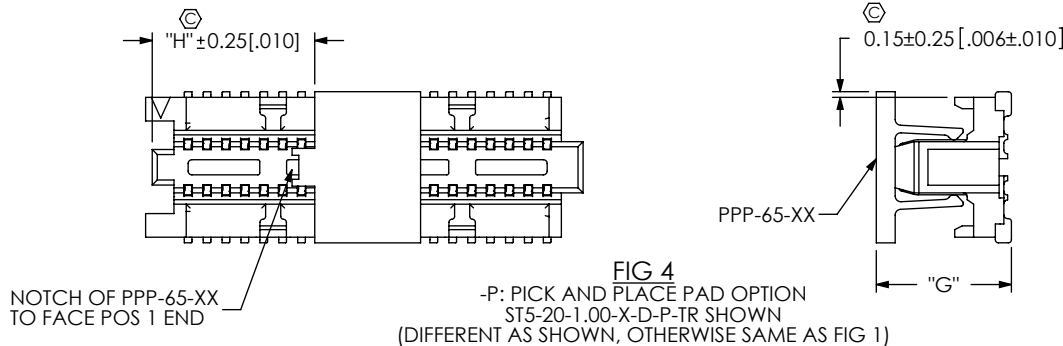
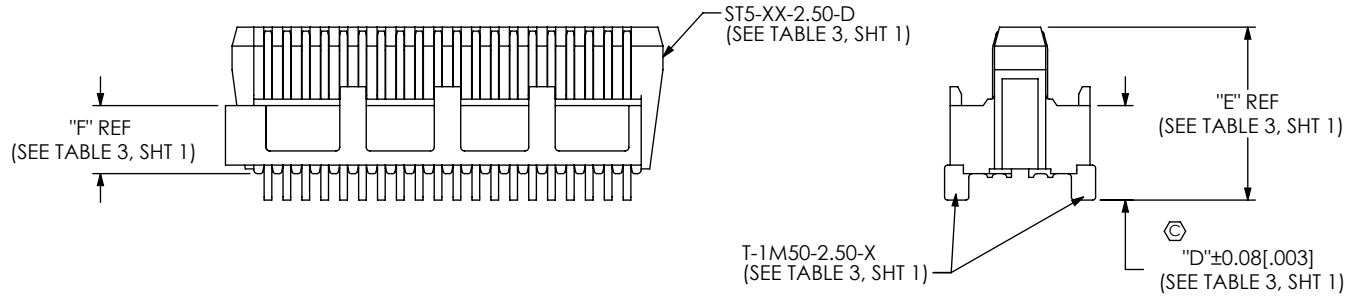

LEAD STYLE	"G"
-1.00	3.58 [0.141]
-1.50	4.08 [0.161]
*-2.50	5.08 [0.200]

(\* = NOT TOOLED)

No OF POS	"H"
-10	1.80 [0.071]
-15	3.22 [0.127]
-20	4.30 [0.169]
-30	6.80 [0.268]
-40	9.30 [0.366]
-50	11.80 [0.465]
-60	14.30 [0.563]
-70	16.80 [0.661]
-80	19.30 [0.760]

**PROPRIETARY NOTE**  
THIS DOCUMENT CONTAINS CONFIDENTIAL AND PROPRIETARY INFORMATION AND ALL DESIGN, MANUFACTURING, REPRODUCTION, USE, PATENT RIGHTS AND SALES RIGHTS ARE EXPRESSLY RESERVED BY SAMTEC, INC. THIS DOCUMENT SHALL NOT BE DISCLOSED, IN WHOLE OR PART, TO ANY UNAUTHORIZED PERSON OR ENTITY NOR REPRODUCED, TRANSFERRED OR INCORPORATED IN ANY OTHER PROJECT IN ANY MANNER WITHOUT THE EXPRESS WRITTEN CONSENT OF SAMTEC, INC.

DO NOT SCALE DRAWING

SHEET SCALE: 5:1



520 PARK EAST BLVD, NEW ALBANY, IN 47150  
PHONE: 812-944-6733 FAX: 812-948-5047  
e-Mail: info@SAMTEC.com code: 55322

DESCRIPTION:  
0.5mm TERMINAL STRIP ASSEMBLY

DWG. NO.  
**ST5-XX-X.XX-X-D-P-TR**

BY: ROY LUO 03/29/2012 SHEET 2 OF 2