

PREPARED BY : DATE

APPROVED BY : DATE

**SHARP**

DISPLAY DEVICE BUSINESS GROUP  
SHARP CORPORATION

**SPECIFICATION**

FILE No. LD-27103A

ISSUE : 09-Jan-15

PAGE : 35pages

APPLICABLE GROUP  
DISPLAY DEVICE BUSINESS GROUP

REVISION : 9-Jan-15

DEVICE SPECIFICATION FOR

**LCD Module**

MODEL No.

**LS013B7DH06**

These parts are complied with the RoHS directive.

CUSTOMER'S APPROVAL

BY \_\_\_\_\_

BY T. Ohnishi

T. Ohnishi

DEPARTMENT GENERAL MANAGER  
DEVELOPMENT DEPARTMENT III  
DISPLAY DEVICE UNIT III  
DISPLAY DEVICE BUSINESS DIVISION  
SHARP CORPORATION



**NOTICE**<<**Precautions**>>

- a) This publication is the proprietary of SHARP and is copyrighted, with all rights reserved. Under the copyright laws, no part of this publication may be reproduced or transmitted in any form or by any means, electronic or mechanical for any purpose, in whole or in part, without the express written permission of SHARP. Express written permission is also required before any use of this publication may be made by a third party.
- b) The application circuit examples in this publication are provided to explain the representative applications of SHARP's devices and are not intended to guarantee any circuit design or permit any industrial property right or other rights to be executed. SHARP takes no responsibility for any problems related to any industrial property right or a third party resulting from the use of SHARP's devices, except for those resulting directly from device manufacturing processes.
- c) When using the products covered herein, please observe the conditions and the precautions written herein. In no event shall the company be liable for any damages resulting from failure to strictly adhere to these conditions and precautions.
- d) SHARP reserves the right to make changes in the specifications, characteristics, data, materials, structures and other contents described herein at any time without notice in order to improve design or reliability. Contact SHARP in order to obtain the latest specification sheets before using any SHARP's device. Manufacturing locations are also subject to change without notice.
- e) The devices in this publication are designed for general electronic equipment use.
- f) The appropriate design measures should be taken to ensure reliability and safety when SHARP's devices are used for equipment such as:
- Transportation control and safety equipment(i.e.,aircraft, trains, automobiles, etc.)
  - Traffic signals
  - Alarm equipment
  - Gas leakage sensor breakers
  - Various safety devices etc.
- g) SHARP's devices shall not be used for equipment that requires extremely high level of reliability, such as:
- Aerospace equipment
  - Nuclear power control equipment
  - Trunk line commucation equipment
  - Military and space applications
  - Medical equipment for life support
- h) Contact and consult with a SHARP representative in advance, if there are any questions about the contents of this publication.

- i) Contact a SHARP representative, in advance, when intending to use SHARP's devices for any "specific" applications other than those recommended by SHARP.
- j) If any problem occurs in relation to the description of this publication, it shall be resolved through discussion with spirit of cooperation each corporation between each corporation.
- k) The ozone-depleting substances are not used.
- l) The device in the production is based on RoHS instructions 95/02. And RoHS instructions materials and chlorinated paraffin are not included intentionally.

### **[Handling Instructions]**

#### **【Handling Precautions】**

- (1) Treat LCD module in dustless surroundings.
- (2) Be sure to turn off the power supply when remove the plugged FPC.
- (3) Be careful not to give any physical stress onto the circuit of LCD module when you plug a FPC. Physical stress will cause a break or worse connection.
- (4) Do not touch or scratch the polarizer with items harder than the surface rating or permanent damage can result.
- (5) Since the LCD panel is made of glass, it may break or crack if dropped or bumped on hard surface. Always handle with care.
- (6) Be careful to handle this LCD panel in order to avoid injury yourself as this panel is made of glass and have sharp edge. When the panel is broken, do not touch the glass. Although the panel is difficult to be scattered, touching the broken part may hurt your hands.
- (7) Since a long contact with water may cause discoloration or spots, wipe it with absorbent cotton or other soft cloth immediately.
- (8) This module contains CGS. Please use appropriate anti-static protection methods for all contact with the LCD panel and its electrical circuits.
- (9) Do not expose to strong ultraviolet rays such as direct sunlight for a long time.
- (10) Liquid crystal contained in the panel may leak if the LCD is broken. If LC material should accidentally come in contact with the mouth or eyes rinse with water as soon as possible, following the instructions of the appropriate MSDS.
- (11) Use N2-blower such as ionized nitrogen has anti-electrostatic when you blow dusts on Polarizer.  
To clean LCD panel surface, wipe clean with absorbent cotton or soft cloth. If further cleaning is needed, use IPA (isopropyl alcohol) and wipe clean lightly on surface only. Do not use organic solvents as it may damage the LCD panel terminal area which uses organic material. Also, do not directly touch with finger. When the terminals cleaning are needed, those should be wiped by a soft cloth or a cotton swab without directly touching by hand.
- (12) To avoid picture uniformity failure, do not put a seal or an adhesive material on the LCD panel surface.

**【Set-Design Precautions】**

- (1) Disassembly of the LCD panel in any way voids the warranty and may permanently damage the LCD panel.
- (2) Do not expose the side of LCD panel and gate driver, etc. on the panel (circuit area outside panel display area) to light as it may not operate properly. Design that shields the side of LCD panel and gate driver, etc. from light is required when mounting the LCD module.
- (3) Support for the LCD panel should be carefully designed to avoid the outside of stress specification on glass surface. Be sure to design the cabinet so that the module can be assembled without any extra stress such as warp or twist.
- (4) It causes an irregular display and the defective indication, etc., when always put constant pressure on the back of the module. Please do not make the structure to press the back of the module.
- (5) In case of attaching a cover glass or touch panel to the front surface, use appropriate measures to avoid degrading optical performance.
- (6) To prevent loss of uniformity and prevent the introduction of contamination to the optical path of the LCD panel, please use fine-pitch filters in the air flow of forced ventilation.
- (7) Be sure to follow the absolute maximum rating in the specification. The design should consider the surrounding temperature, the fluctuating input signal, and tolerance of the electronic parts. Exceeding values is possible to cause worse characteristic such as burn and/or broken of the parts on LCD module.
- (8) Be sure to use LCD module within the recommended Electrical Characteristics and Timing Characteristics of Input Signals conditions. Operating module out of the recommended range is not guaranteed even if it is in the absolute maximum rating.
- (9) Follow the power, signal, and supply voltage sequence which the specification indicates, regarding on-off input signal after power on of LCD module.
- (10) According to the using application, power circuit protection is recommended at module failure.
- (11) When handling LCD modules and assembling them into the cabinet, please avoid long-term storage in the environment of oxidization or deoxidization gas. The use of materials such as reagent, solvent, adhesive, resin, etc. which generate these gasses, may cause corrosion and discoloration of the modules.  
Do not use the LCD module under such environment.
- (12) To avoid picture uniformity failure, do not put a seal or an adhesive material on the LCD panel surface.
- (13) Protection film is attached to the module surface to prevent it from being scratched. Peel the film off slowly, just before the use, with strict attention to electrostatic charges. Blow off 'dust' on the polarizer by using an ionized nitrogen.  
After peeling the protection film off, please do not reattach to the front polarizer. If you reattach and store it long time, surface of the front polarizer changes in quality and it may cause display non-uniformity issue.
- (14) Panel is susceptible to mechanical stress and such stress may affect the display. Place the LCD panel on flat surface to avoid stress caused by twist, bend, etc.

(15) To prevent reduction in optical quality and abnormal display, avoid exposure and contamination of the LCD panel from epoxy resin (mine system curing agent) that comes out from the material and the packaging material used for the set side, the silicon adhesive (dealcoholization system and oxime system), and the tray blowing agents ( azo-compound), etc. Please confirm LCD panel compatibility with materials employed in your manufacturing and shipping processes.

(16) Since the LCD panel is made of glass, it may break or crack if dropped or bumped on hard surface. Always handle with care.

(17) Please design part arrangement to consider the heat dissipation not to change the local temperature for module.

(18) This product is not water-proof and dust-proof structure.

(19) As this LCD module is composed electronic circuits, it is sensitive to electrostatic discharge of 200V or more.

Handle with care using cautions for the followings:

- Operators

Operators must wear anti-static wears to prevent electrostatic charge up to and discharge from human body.

- Equipment and containers

Process equipment such as conveyer, soldering iron, working bench and containers may possibly generate electrostatic charge up and discharge. Equipment must be grounded through 100Mohms resistance. Use ion blower.

- Floor

Floor plays an important role in leaking static electricity generated in human body or equipment. If the floor is made of insulated material (such as polymer or rubber material), such static electricity may charge. Proper measure should be taken to avoid static electricity charge (electrostatic earth: 100Mohms). There is a possibility that the static electricity is charged to them without leakage in case of insulating floor, so the electrostatic earth: 100Mohms should be made.

- Humidity

Humidity in work area relates to surface resistance of the persons or objects that generate electrostatics, and it can be manipulated to prevent electrostatic charge. Humidity of 40% or lower increases electrostatic earth resistance and promotes electrostatic charging. Therefore, the humidity in the work area should be kept above 40%. Specifically for film peeling process or processes that require human hands, humidity should be kept above 50% and use electricity removal blower.

- Transportation/Storage

Containers and styroform used in transportation and storage may charge electrostatic (from friction and peeling) or electrostatic charge from human body, etc. may cause containers and styroform to have induced charge. Proper electrostatic measure should be taken for containers and storage material.

**【Operation Precautions】**

- (1) Do not use polychloroprene (CR) with LCD module. It will generate chlorine gas, which will damage the reliability of the connection part on LCD panel.
- (2) Be sure to use LCD module within the recommended operating conditions. Operating module out of the recommended range is not guaranteed even if it is in the absolute maximum rating.
- (3) When handling LCD modules and assembling them into cabinets, please avoid long-term storage in the environment of oxidization or deoxidization gas. The use of materials such as reagent, solvent, adhesive, resin, etc. which generate these gasses, may cause corrosion and discoloration of the modules. Do not use the LCD module under such environment.
- (3) To prevent reduction in optical quality and abnormal display, avoid exposure and contamination of the LCD panel from epoxy resin (amine system curing agent) that comes out from the material and the packaging material used for the set side, the silicon adhesive (dealcoholization system and oxime system), and the tray blowing agents ( azo-compound), etc.  
Please confirm LCD panel compatibility with materials employed in your manufacturing and shipping processes.
- (4) If stored at the temperatures lower than the rated storage temperature, the LC may freeze and it may cause LCD panel damage. And If stored at the temperatures higher than the rated storage temperature, the LC will lose its characteristics, and it cannot recover. Please keep it at near room temperature.
- (5) Do not operate the LCD panel under outside of electrical specification. Otherwise LCD panel may be damaged.
- (6) Do not use the LCD panel under outside of specified driving timing chart. Otherwise LCD panel may not have proper picture quality.
- (7) A still image should be displayed less than two hours, if it is necessary to display still image longer than two hour, display image data must be refreshed in order to avoid sticking image on LCD panel.
- (8) If LCD module takes a static electricity, as the display image which is written into pixel memory might not be displayed, Data update should be executed frequently.
- (9) It is neither a breakdown nor a defective indication though very slight change in black level might be periodically seen in a black part on the black display image according to the source of light (angle of the luminance and the source of light).
- (10) Be sure to follow the absolute maximum rating in the specification. The design should consider the surrounding temperature, the fluctuating input signal, and tolerance of the electronic parts. Exceeding values is possible to cause worse characteristic such as burn and/or broken of the parts on LCD module.
- (11) Follow the power, signal, and supply voltage sequence which the specification indicates, regarding on-off input signal after power on of LCD module.
- (12) According to the using application, power circuit protection is recommended at module failure.
- (13) Nature of dew consideration prevention is necessary when LCD is used for long time under high-temperature and high-humidity

## . [Precautions for Storage]

(1) After opening the package, do not leave the LCD panel in direct sun or under strong ultraviolet ray. Store in the dark place.

(2) In temperature lower than specified rating, liquid crystal material will coagulate. In temperature higher than specified rating, it will liquefies. In either condition, the liquid crystal may not recover its original condition. Store the LCD panel in at or around room temperature as much as possible.

Also, storing the LCD panel in high humidity will damage the polarizer. Store in normal room temperature as much as possible.

### (3) Keeping Method

a. Don't keeping under the direct sunlight.

b. Keeping in the tray under the dark place.

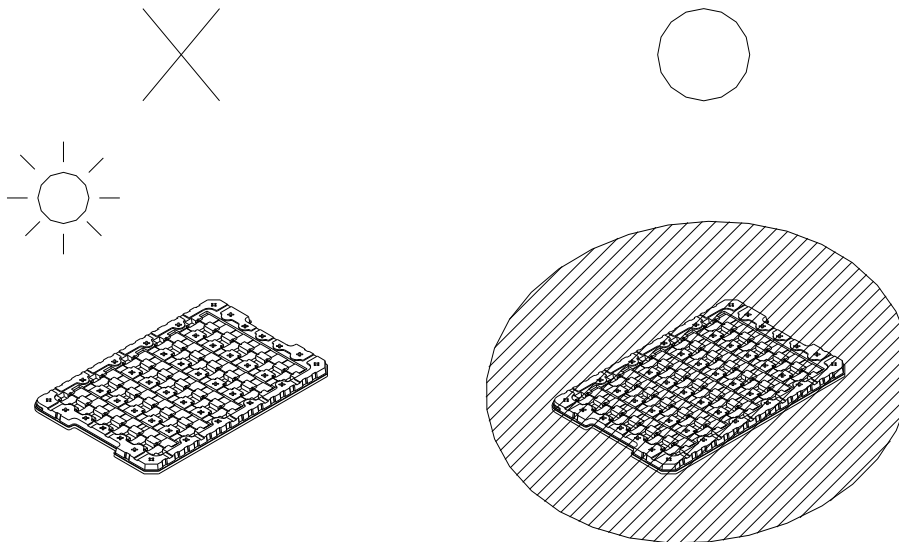



**[Other Notice]**

- (1) Operation outside specified environmental conditions cannot be guaranteed.
- (2) As power supply (VDD-GND, VDDA-GND) impedance is lowered during use, bus controller should be inserted near LCD module as much as possible.
- (3) Polarizer is applied over LCD panel surface. Liquid crystal inside LCD panel deteriorates with ultraviolet ray. The panel should not be left in direct sun or under strong ultraviolet ray for prolonged period of time even with the polarizer.
- (4) Disassembling the LCD module will cause permanent damage to the module. Do not disassemble the module.
- (5) If LCD panel is broken, do not ingest the liquid crystal from the broken panel. If hand, leg or clothes come in contact with liquid crystal, wash off immediately with soap. If mouth or eyes come in contact with liquid crystal, rinse with water as soon as possible, following the instructions of the appropriate MSDS.
- (6) ODS (specific chlorofluorocarbon, specific halon, 1-1-1 trichloroethane, carbon tetrachloride) are not used or contained in material or all production processes of this product.
- (7) Observe all other precautionary requirements in handling general electronic components.

**Discarding liquid crystal modules**

Follow the regulations when LCD module is scrapped. The government you stay may have some regulations about it.

LCD Panel : Dispose of as glass waste. This LCD module contains no harmful substances.

The liquid crystal panel contains no dangerous or harmful substances.

This liquid crystal panel contains only an extremely small amount of liquid crystal (approximately 100mg) and therefore it will not leak even if the panel should break.

Its median lethal dose (LD50) is greater than 2,000 mg/kg and a mutagenetic (Aims test: negative) material is used.

## Contents

<b>1. Applicable Color Memory liquid crystal display.....</b>	<b>9</b>
<b>2. Characteristics .....</b>	<b>9</b>
<b>3. Mechanical Specification .....</b>	<b>9</b>
<b>4. Input terminal names and functions .....</b>	<b>10</b>
<b>5. Absolute Maximum Rating.....</b>	<b>11</b>
<b>6. Electrical characteristics.....</b>	<b>11</b>
<b>7. Optical specification.....</b>	<b>21</b>
<b>8. Module outline.....</b>	<b>23</b>
<b>9. Display Qualities .....</b>	<b>24</b>
<b>10. External capacitors.....</b>	<b>28</b>
<b>11. Marking .....</b>	<b>29</b>
<b>12. Packaging form .....</b>	<b>29</b>
<b>13. Reliability Test Conditions.....</b>	<b>31</b>

## **1. Applicable Color Memory liquid crystal display**

This TFT-LCD module is a reflective active-matrix Color memory liquid crystal display module with CG silicone thin film transistor. Module outline is indicated in Figure 8-1

## **2. Characteristics**

- Reflective active-matrix with slightly transmissive panel of RGB with aspect ratio of 1:1.
- 1.33" screen has 128 x 128 resolution. (16384 pixels stripe array)
- 1 pixel has RGB each 1bit, the pixel can display 8 colors.
- Display control by serial data signal communication.
- Arbitrary line data renewable.
- 1bit internal memory for data storage within the panel.
- Thin, light-weight and compact module with monolithic technology.
- Super low power consumption TFT panel.
- Front polarizer surface is Antiglare.
- With FPC (Applicable connector : Ref to recommended connector on Page 26)

## **3. Mechanical Specification**

Table 3-1 Module mechanical specification

Item	Specification	unit
Screen size	1.33"	inch
Viewing Area	23.808(H) × 23.808(V)	mm
Dot configuration	128(H) × 3(RGB) × 128(V)	Dot
Dot pitch	0.062(H) × 0.186(V)	mm
Pixel Array	Stripe Array	-
Outline Dimension	26.82(W) × 31.3(H) × 0.745(D)	mm
Mass	1.25 typ	g
Surface Hardness	at least 3H (initial)	Pencil hardness

(Note) Detail dimension and tolerance are shown in Figure.8-1

## 4. Input terminal names and functions

Table4-1 Pin description

Terminal	Symbol	I/O	Configurations	Function	Remark
1	SCLK	INPUT	NoPull	Serial clock signal	
2	SI	INPUT	NoPull	Serial data input signal	
3	SCS	INPUT	NoPull	Chip select signal ( Active of Hi )	
4	EXTCOMIN	INPUT	NoPull	External COM inversion signal input (Input Square wave or connect the VSS)	【Note 4-2】
5	DISP	INPUT	NoPull	Display ON/OFF signal	【Note 4-1】
6	VDDA	POWER	—	Power supply (Analog)	
7	VDD	POWER	—	Power supply (Digital)	
8	EXTMODE	INPUT	NoPull	Control mode of COM inversion is select terminal ( connect the VDD or VSS )	【Note 4-2】
9	VSS	GND	—	GND (Digital)	
10	VSSA	GND	—	GND (Analog)	

※ NoPull : Neither Pulled up or Pulled down.

【Note 4-1】 The display ON/OFF signal is only for display. Data in the memory will be saved at the time of ON/OFF. When it's "Hi", data in the memory will display, when it's "Lo", white color will display and data in the memory will be saved.

【Note 4-2】 When EXTMODE is "Hi", EXTCOMIN signal is enable.

When EXTMODE is "Lo", serial input flag is enable.

"Hi" mode ; connect the EXTMODE to VDD,

"Lo" mode ; connect the EXTMODE and EXTCOMIN to VSS.

### 4-1) Recommended Circuit

< EXTMODE="Lo" >

COM Signal Serial Flag Input

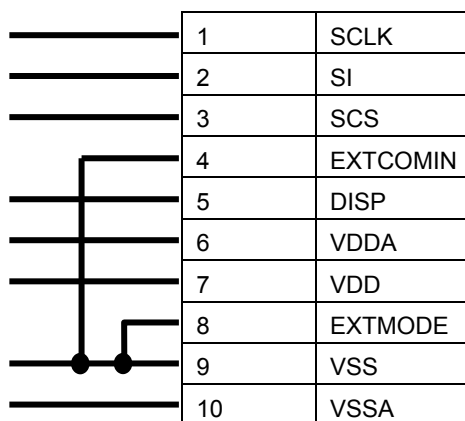

< EXTMODE="Hi" >

External COM Signal Input

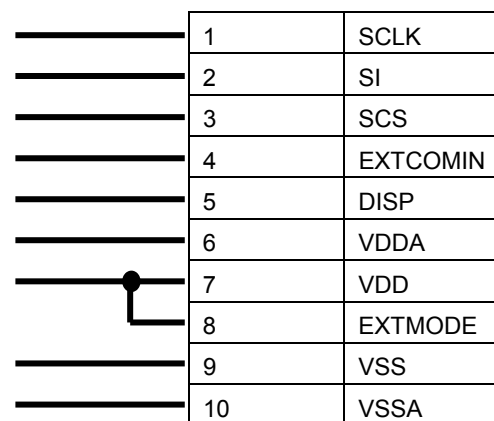

Figure 4-1 Recommended circuit

## 5. Absolute Maximum Rating

Table5-1 Absolute Maximum Rating

( GND=0V )

Item		Symbol	Min	Max	Unit	Remark
Power supply voltage	Analog	VDDA	-0.3	+5.8	V	
	Logic	VDD	-0.3	+5.8	V	[Note 5-1]
Input signal voltage(high)				VDD	V	[Note 5-2]
Input signal voltage(low)			-0.3		V	
Storage Temperature		Tstg	-30	80	°C	[Note 5-3,4]
Operation Temperature (at panel surface)		Topr1	-20	70	°C	[Note 5-4,5]

[Note 5-1] Applies to EXTMODE.

[Note 5-2] Applies to SCLK, SI, SCS, DISP, EXTCOMIN.

[Note 5-3] Do not exceed this temperature in any parts of module.

[Note 5-4] Maximum wet bulb temperature is 57°C or lower. No condensation is allowed.

Condensation will cause electrical leak and may cause the module to not meet this specification.

[Note 5-5] Operating temperature is the temperature that guarantees only for the operation.

For contrast, response time, and other display quality determination, use Ta = +25°C.

## 6. Electrical characteristics

### 6-1) TFT LCD panel drive

Table6-1 Recommended operating Condition

VSS(GND)=0V, Ta = +25°C

Item		Symbol	Min.	Typ.	Max.	Unit	Remark
Power supply Voltage	Analog	VDDA	+4.8	+5.0	+5.5	V	
	Logic	VDD	+4.8	+5.0	+5.5	V	[Note 6-1]
Input signal voltage	Hi	VIH	+2.7	+3.0	*VDD	V	[Note 6-2]
	Lo	VIL	VSS	VSS	VSS+0.15	V	

\*It can be operated below VDD voltage, however, operation around 3V is recommended.

[Note 6-1] Applies to EXTMODE="Hi"

[Note 6-2] Applies to SCLK, SI, SCS, DISP, EXTCOMIN.

## 6-2) Power supply sequence

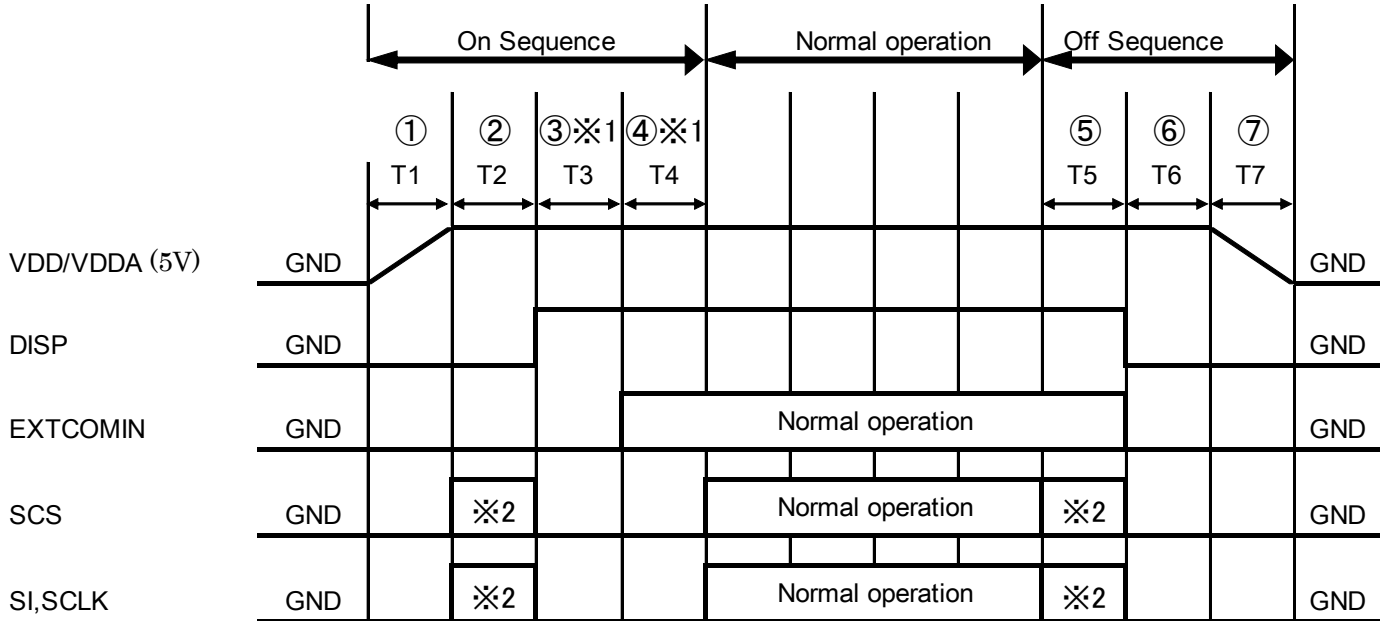

Figure 6-1 Power supply sequence

※Refer to timing chart and AC timing characteristics for detail

※1 ③ and ④ may be opposite

(however, TCOM polarity inversion will not occur even with EXTCOMIN between DISP="Lo". Also, when DISP and EXTCOMIN are simultaneously started up, allow 30us or more before SCS starts up (It may be less than 60us).

※2 Setting value for pixel memory initialization

SCS=Driving accordingly to clear pixel internal memory method

(use all clear flag or write all screen white)

S1=M2 (all clear flag) = "Hi" or write white

SCLK: Normal Driving

[ON Sequence]

(1) 5V rise time (depends on IC)

(2) Pixel memory initialization

T2: 1 time or more Initialize with M2 (all clear flag) or write all screen white

(3) Release time for initialization of TCOM latch

T3: 30us or more

Time required to release COM related latch circuit initialization which is initializing using DISP signals

(4) TCOM polarity initialization time

T4: 30us or more

Time required initializing TCOM polarity accordingly to EXTCOMIN input

[Normal Operation]

Duration of normal driving

[Off Sequence]

(5) Pixel memory initialization

T5: 1 time or more Initialize with M2 (all clear flag) or write all screen white

(6) VA, VB, VCOM initialization time

T6: 30us or more

(7) 5V falling time (Depends on IC)

(Note ) Precautions at ehte time of power on and power off.

※1) When power on , VDDand VDDA are same timem or VDD should be faster than the VDDA.

※2) When power off, VDD and VDDA are same time or VDDA shoud be faster than the VDD.

### 6-3) Input signal characteristics

Table6-3-1 Recommend Operating Cunditions and DC Characteristics

VDDA=+5.0V、VDD=+5.0V、GND=0V、Ta=25°C

Item	Symbol	Min	Typ	Max	Unit	Remark
Frame frequency	fSCS	1	1	35	Hz	<b>【Note 6-3】</b>
Clock frequency	fSCLK	-	1	2	MHz	
Vertical Interval	tV	28.6	-	1000	ms	
COM Frequency	fCOM	0.5	-	17.5	Hz	

**【Note 6-3】** Please use afram frequency in the range where there are no problems with the display quality.

Table 6-3-2 Input Signal timing Parameters

VDDA=+5.0V、VDD=+5.0V、GND=0V、Ta=25°C

Item	Symbol	Min	Typ	Max	Unit	Remark
SCS Rising time	trSCS	-	-	50	ns	
SCS Falling Time	tfSCS	-	-	50	ns	
SCS High duration	twSCSH	212	-	-	us	Display update mode
		12	-	-	us	Display mode
SCS Low duration	twSCSL	1	-	-	us	
SCS set up time	tsSCS	3	-	-	us	
SCS hold time	thSCS	1	-	-	us	
SI Rising time	trSI	-	-	50	ns	
SI Folling time	tfSI	-	-	50	ns	
SI Set up time	tsSI	120	-	-	ns	
SI Hold time	thSI	190	-	-	ns	
SCLK Rising time	trSCLK	-	-	50	ns	
SCLK Folling time	tfSCLK	-	-	50	ns	
SCLK High duration	twSCLKH	200	450	-	ns	
SCLK Low duration	twSCLKL	200	450	-	ns	
EXTCOMIN signal frequency	fEXTCOMIN	1	1	35	Hz	<b>【Note 6-4】 【Note 6-5】</b>
EXTCOMIN signal rising time	trEXTCOMIN	-	-	50	ns	
EXTCOMIN signal folling time	twEXTCOMIN	-	-	50	ns	
EXTCOMIN signal High duration	thIEXTCOMIN	1	-	-	us	
DISP Rising time	trDISP	-	-	50	ns	
DISP Folling time	tfDISP	-	-	50	ns	

**【Note 6-4】** When data is writtne for displaying continuously, EXTCOMIN frequency should be made the same frame frequency or lower.

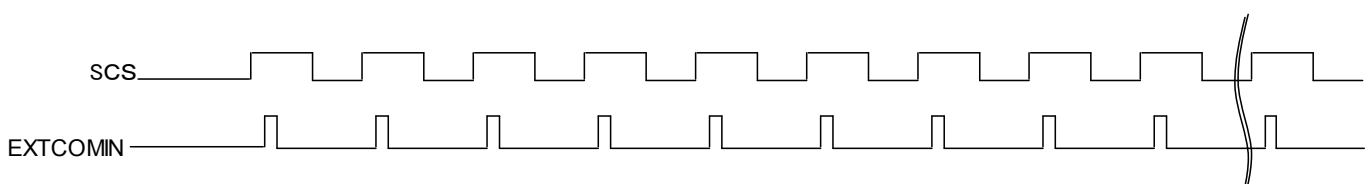

Figure 6-2 EXTCOMIN Signal 1



【Note 6-5】When the display is maintained after writing of the displayed data, is not applied.  
(Please keep SCS in the state of L when you maintain current display after writing of the display data.)

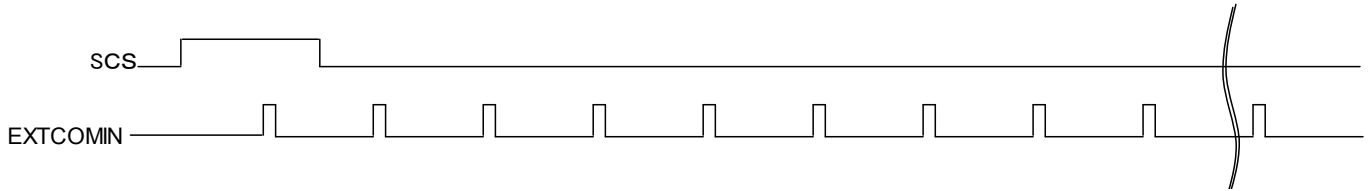
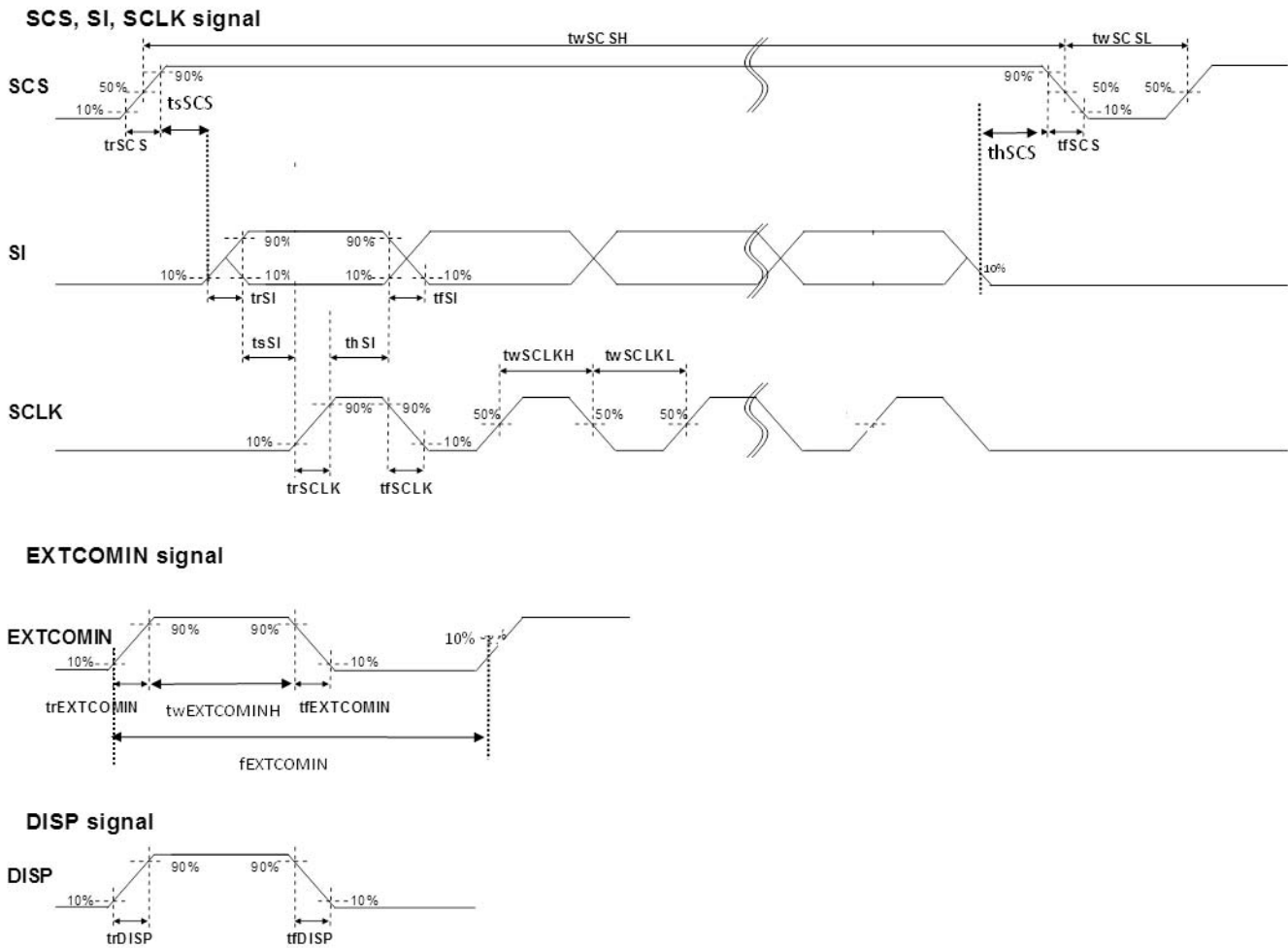

Figure 6-3 EXTCOMIN Signal 2

### 6-4) Signal Timing



※SCS,SI,SCLK、DISP、EXTCOMIN: 3V input voltage

Figure 6-4 Signal Timing

## 6-5) Power consumption

Table6-4 Current Consumption Ta=25°C,SCS SCLK,Si,DISP,EXTCOMIN=+3V ,VDD=+5V, VDDA=+5V

Operating Mode	Power consumption	Min	Typ	Max	unit	Remark
Condition 1	Display mode (no display data update) Display pattern : <b>Black display</b>	—	25	120	uW	[Note 6-5]
Condition 2	Data update mode with display update 1Hz (1fram/sec) Display pattern : <b>Vertical stripe display</b>	—	60	300	uW	[Note 6-5] [Note 6-6]

[Note 6-5]

- a) SCLK=Lo , SCS=Lo , SI=Lo (after writed Black data)
- b) It measures after writed Black data.

[Note 6-6]

- a) fSCS=1.0Hz (Except in the time of writing, it is set to SCS=Lo .)

Common inversion with VDD=5.0V、VDDA=5.0V、fCLK=1.0MHz、EXTMODE=VDD、EXTCOMIN=1Hz

[ Common Note ]

- a) This is value in steady condition, not the falue of peak power at the time of COM operation.
- b) Some marging for power supply is recommended.
- c) We recommend capacitor for VDD and VDDA.  
(If VDD and VDDA are on separate systems, we recommend capacitor for each.)

\*LC inversion :

- LC material is needed alternative polarity driving as changing timing which should be 1Hz.  
( LC inversion frequency 1Hz is COM frequency 0.5Hz)

as shown Figure 6-5

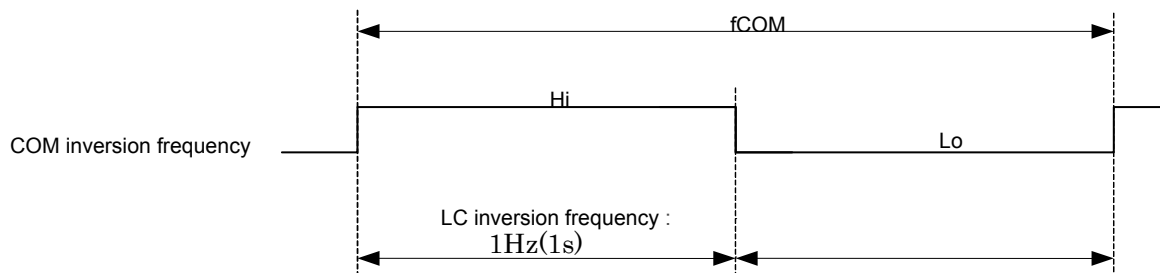

Figure 6-5 COM inversion frequency

## 6-6) Input Signal Timing Chart

### 6-6-1 Data update mode (1 line)

Updates data of only one specified line. (M0="Hi", M2="Lo")

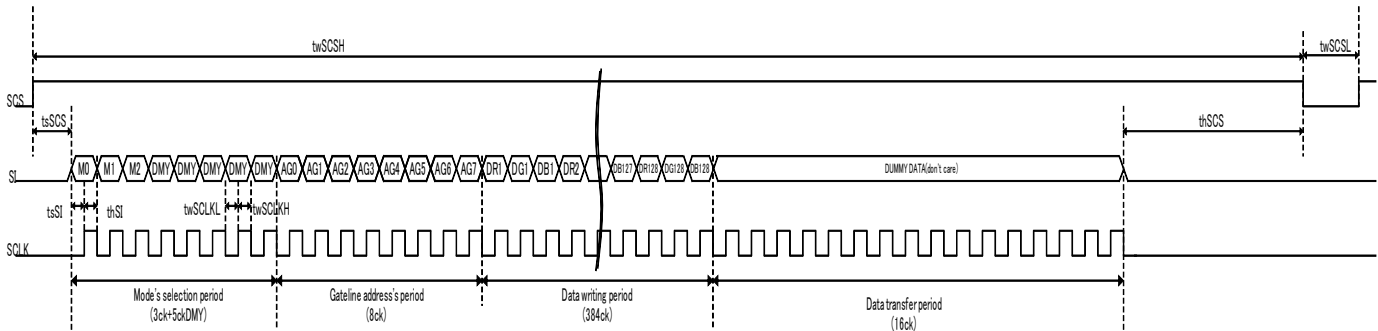

Figure 6-6 Data update mode by 1line

M0: Mode flag.

Set for "Hi". Data update mode (Memory internal data update)  
When "Lo", display mode (maintain memory internal data).

M1: Frame inversion flag.

When "Hi", outputs VCOM="Hi", and when "Lo", outputs VCOM="Lo".  
When EXTMODE="Hi", it can be "Hi" or "Lo".

M2: All clear flag.

Refer to 6-6-4) All Clear Mode to execute clear.

DUMMY DATA: Dummy data. It can be "Hi" or "Lo" ("Lo" is recommended.)

- ※ Data write period  
Data is being stored in 1<sup>st</sup> latch block of binary driver on panel.
- ※ Data transfer period  
Data written in 1<sup>st</sup> latch is being transferred (written) to pixel internal memory circuit.

※For gate line address setting, refer to 6-7) Input Signal and Display.

※M1: Frame inversion flag is enabled when EXTMODE="Lo".

※When SCS becomes "Lo", M0 and M2 are cleared.

## 6-6-2 Data Update Mode (Multiple Lines)

Updates arbitrary multiple lines data. (M0="Hi", M2="Lo")

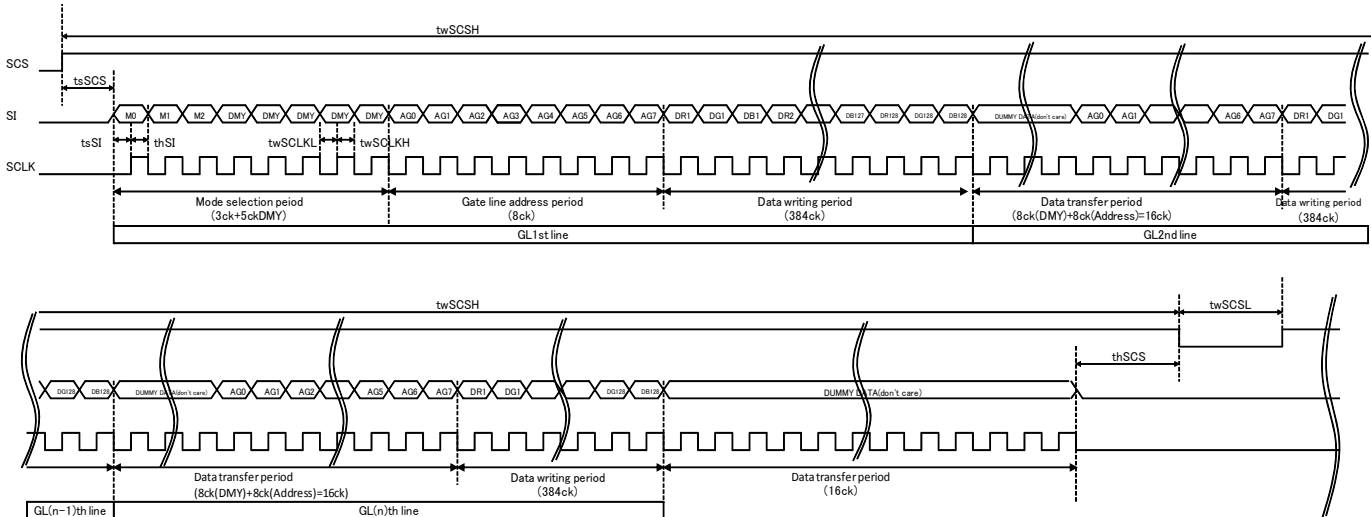

Figure 6-7 Data update mode by Multiple Lines

### M0: Mode flag.

Set for "Hi". Data update mode (Memory internal data update)  
When "Lo", display mode (maintain memory internal data).

### M1: Frame inversion flag.

When "Hi", outputs VCOM="Hi", and when "Lo", outputs VCOM="Lo".  
When EXTMODE="Hi", it can be "Hi" or "Lo".

### M2: All clear flag.

Refer to 6-6-4) All Clear Mode to execute clear.

DUMMY DATA: Dummy data. It can be "Hi" or "Lo" ("Lo" is recommended.)

- ※ Data write period  
Data is being stored in 1<sup>st</sup> latch block of binary driver on panel.
- ※ Data transfer period  
For example, during GL2<sup>nd</sup> line data transfer period, GL 2<sup>nd</sup> line address is latched and GL 1<sup>st</sup> line data is transferred from 1<sup>st</sup> latch to pixel internal memory circuit at the same time.

※ For gate line address setting, refer to 6-7) Input Signal and Display.

※ Input data continuously.

※ M1: Frame inversion flag is enabled when EXTMODE="Lo".

※ When SCS becomes "Lo", M0 and M2 are cleared.

## 6-6-3 Display Mode

Maintains memory internal data (maintains current display). (M0="Lo", M2="Lo")

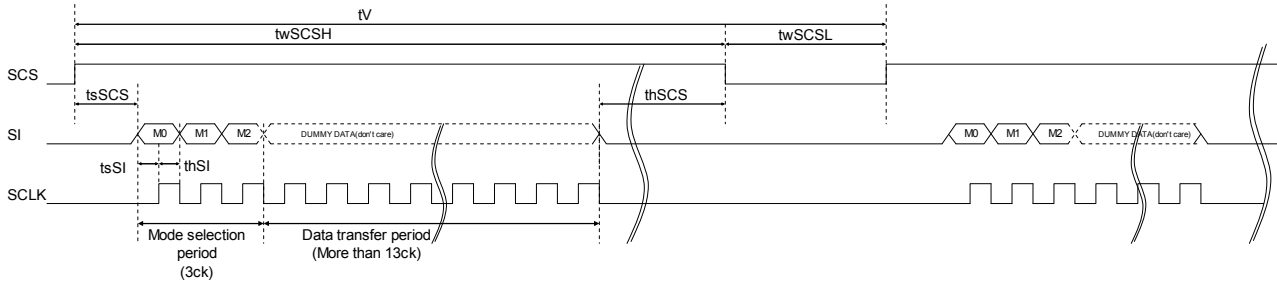

Figure 6-8 Display mode

M0: Mode flag.

Set for "Hi". Data update mode (Memory internal data update)  
When "Lo", display mode (maintain memory internal data).

M1: Frame inversion flag.

When "Hi", outputs VCOM="Hi", and when "Lo", outputs VCOM="Lo".  
When EXTMODE="Hi", it can be "Hi" or "Lo".

M2: All clear flag.

Refer to 6-6-4) All Clear Mode to execute clear.

DUMMY DATA: Dummy data. It can be "Hi" or "Lo" ("Lo" is recommended.)

※ M1: Frame inversion flag is enabled when EXTMODE="Lo"

※ When SCS becomes "Lo", M0 and M2 are cleared.

## 6-6-4 All Clear Mode

Clears memory internal data and writes white. (M0="Lo", M2="Hi")

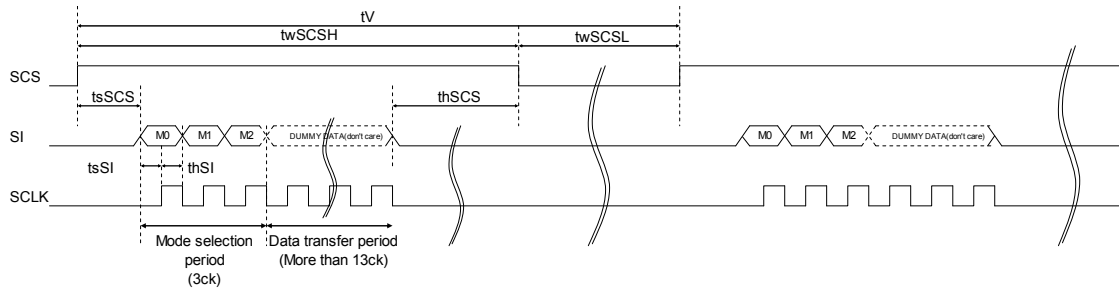

Figure 6-9 All Clear mode

M0: Mode flag.  
Set it "Lo".

M1: Frame inversion flag.  
When "Hi", outputs VCOM="Hi", and when "Lo", outputs VCOM="Lo".  
When EXTMODE="Hi", it can be "Hi" or "Lo".

M2: All clear flag.  
Set it "Hi"

DUMMY DATA: Dummy data. It can be "Hi" or "Lo" ("Lo" is recommended.)

※ M1: Frame inversion flag is enabled when EXTMODE="Lo".

※ When SCS becomes "Lo", M0 and M2 are cleared.

## 6-6-5 COM Inversion

There are two types of inputs, COM signal serial input (EXTMODE="Lo") and external COM signal input (EXTMODE="Hi").

### EXTMODE="Lo"

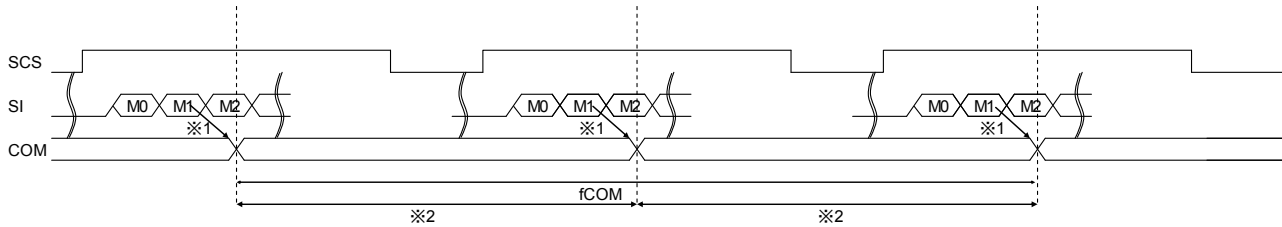

Figure 6-10 COM Inversion (EXTMODE=Lo)

M1: LC polarity inversion flag:

If M1 is "Hi" then VCOM="Hi" is output.

If M1 is "Lo" then VCOM="Lo" is output.

※1: LC inversion has been changed by M1 flag statement.

※2: The periods of plus polarity and minus polarity should be same length as much as possible.

### EXTMODE="Hi" (COM inversion timing has two conditions )

① EXTCOMIN input during high period of the SCS signal

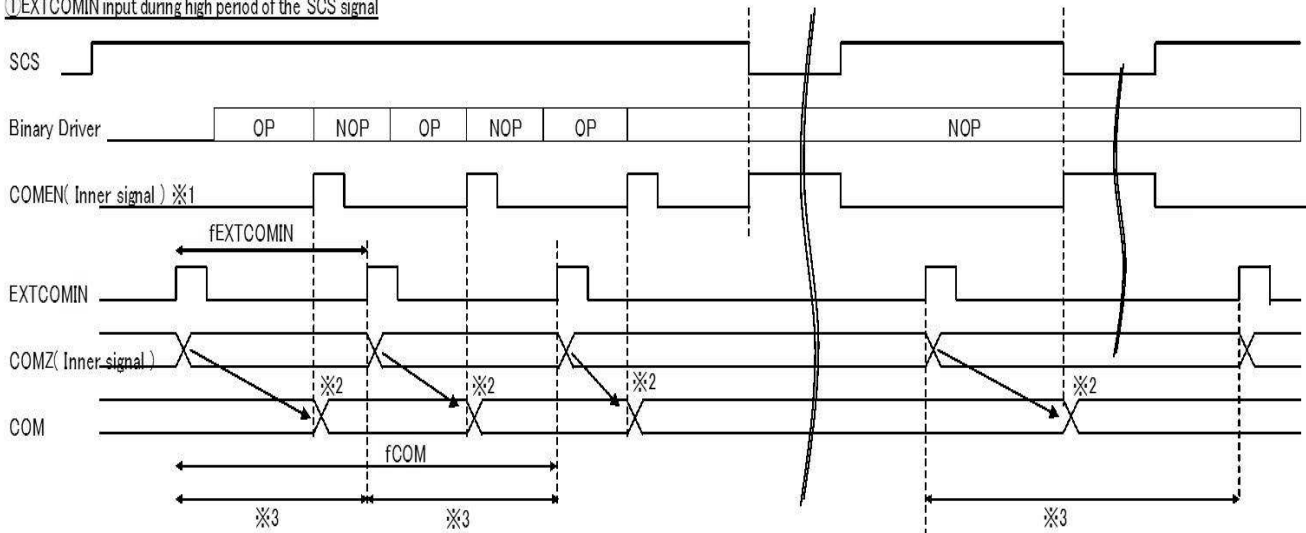

※1: COMEN is High when "SCS = Low" and certain period after Binary Driver operation.

※2: Make "COM" reversal depending on COMZ at the COMEN's rise time.

※3: The period of EXTCOMIN should be constant.

And the period of COM inversion should be constant depending on EXTCOMIN. (with Binary Driver operate or making the period of "SCS = Low")

Figure 6-11 COM Inversion 1 (EXTMODE=Hi)

②: the EXTCOMIN input during low period of the SCS signal .

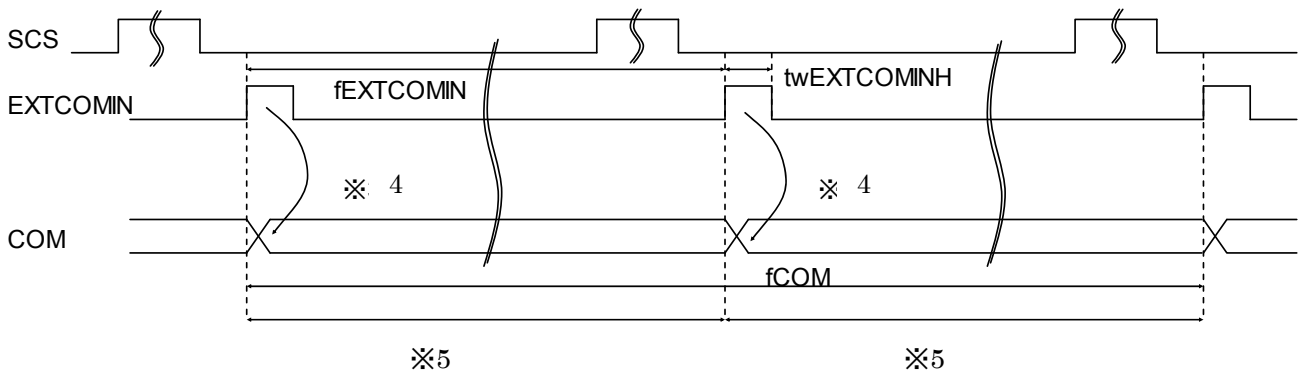

※4 LC inversion polarity has been set by the rising edge of EXTCOMIN.

※5 The period of EXTCOMIN should be constant.

Figure 6-12 COM Inversion 2 (EXTMODE=Hi)



## 6-7) Input Signal and Display, Gate address(Line) Setting

<Data position in display[H,V]>

<Gate line address setting>

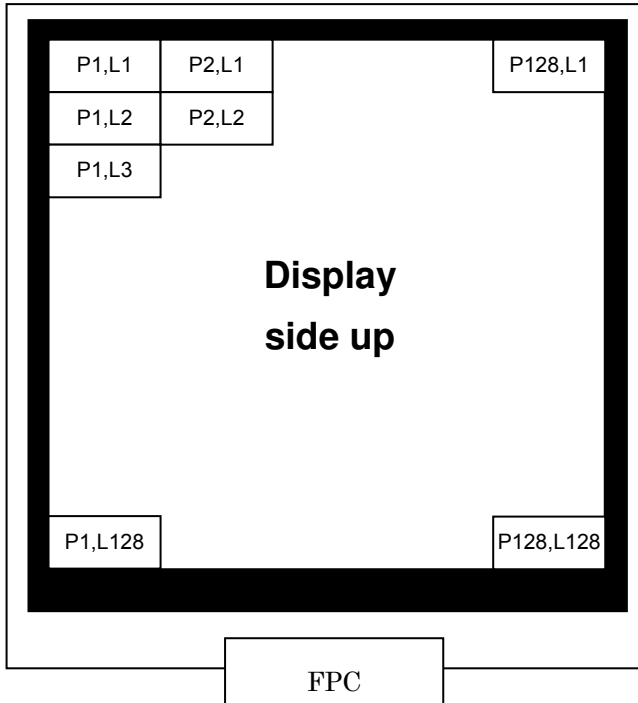

P\*: Pixels position

L\*:Gate address line

GL	AG0	AG1	AG2	AG3	AG4	AG5	AG6	AG7
1	1	0	0	0	0	0	0	0
2	0	1	0	0	0	0	0	0
3	1	1	0	0	0	0	0	0
4	0	0	1	0	0	0	0	0
5	1	0	1	0	0	0	0	0
7	0	1	1	0	0	0	0	0
8	1	1	1	0	0	0	0	0
:	:	:	:	:	:	:	:	:
121	1	0	0	1	1	1	1	0
122	0	1	0	1	1	1	1	0
123	1	1	0	1	1	1	1	0
124	0	0	1	1	1	1	1	0
125	1	0	1	1	1	1	1	0
126	0	1	1	1	1	1	1	0
127	1	1	1	1	1	1	1	0
128	0	0	0	0	0	0	0	1

GL: Gate address line

<Block diagram of the pixel>

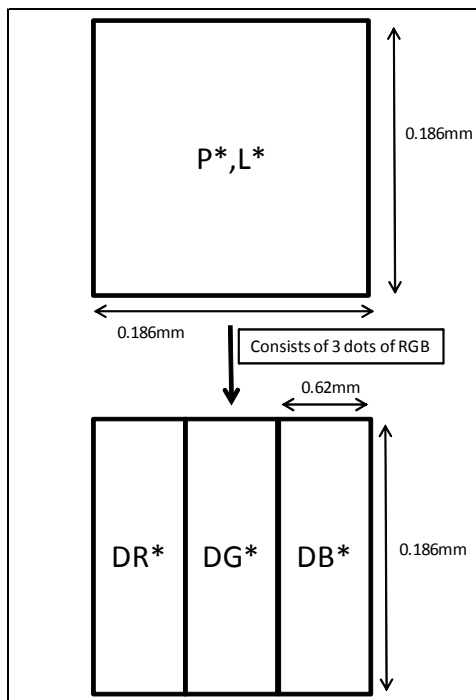

<Color Data Table>

Color	DR*	DG*	DB*
Black	0	0	0
Red	1	0	0
Green	0	1	0
Yellow	1	1	0
Blue	0	0	1
Magenta	1	0	1
Cyan	0	1	1
White	1	1	1

Figure 6-13 Data position

## 7. Optical specification

Table 7-1 Optical specification

VDD=VDDA=5V, Ta=25°C

Item	Symbol	Min.	Typ.	Max.	unit	Remark	
Viewing angle range CR $\geq$ 2	Horizontal	$\theta_{21}, \theta_{22}$	40	60	-	°(degree)	[Note 7-1]
	Vertical	$\theta_{11}$	40	60	-	°(degree)	
		$\theta_{12}$	40	60	-	°(degree)	
Contrast ratio	CR	15	24	-		[Note 7-2,3]	
Reflecivity ratio	R	6.5	8.5	-	%	[Note 7-3]	
Transmissivity ratio	T	-	0.15	-	%		
Response time	Rise	$\tau_r$	-	10	20	ms	[Note 7-3,4]
	Fall	$\tau_d$	-	20	40	ms	
Panel Chromaticity	White	x	-	0.30	-		[Note 7-3]
		y	-	0.34	-		
	Red	x	-	0.41	-		
		y	-	0.31	-		
	Green	x	-	0.30	-		
		y	-	0.40	-		
	Blue	x	-	0.21	-		
		y	-	0.28	-		
NTSC ratio		-	6.0	-	%		

[Note 7-1] Defintion of Viewing Angle

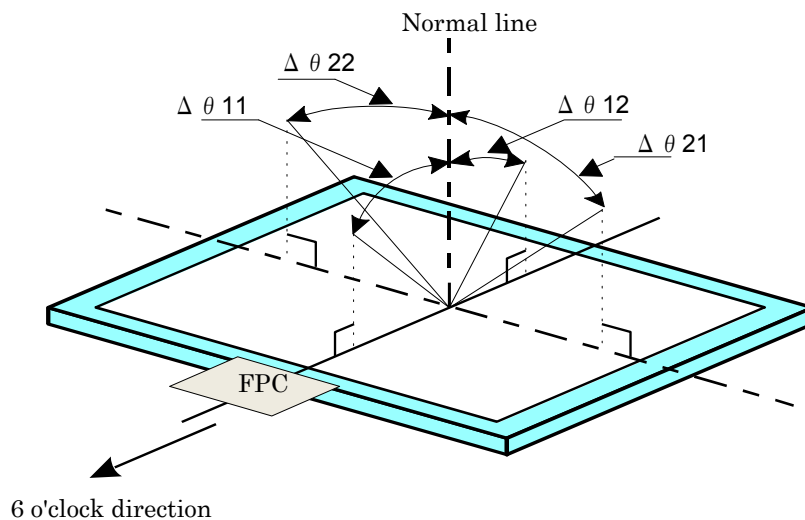

Figure 7-1 Defintion of Viewing Angle

[Note 7-2] Definition of Contrast Ratio

The contrast ratio is defined as the following.

$$\text{Contrast ratio(CR)} = \frac{\text{Reflection intensity in white display}}{\text{Reflection intensity in black display}}$$

[Note 7-3] Optical characteristics measurement equipment.

Figure 7-2 is for contrast ratio, reflectivity ratio, and panel chromaticity measurement, and Figure 7-3 is for response time measurement. Both are to be conducted in a dark or room equipped to a dark room

Measurement equipment

(CM700d)

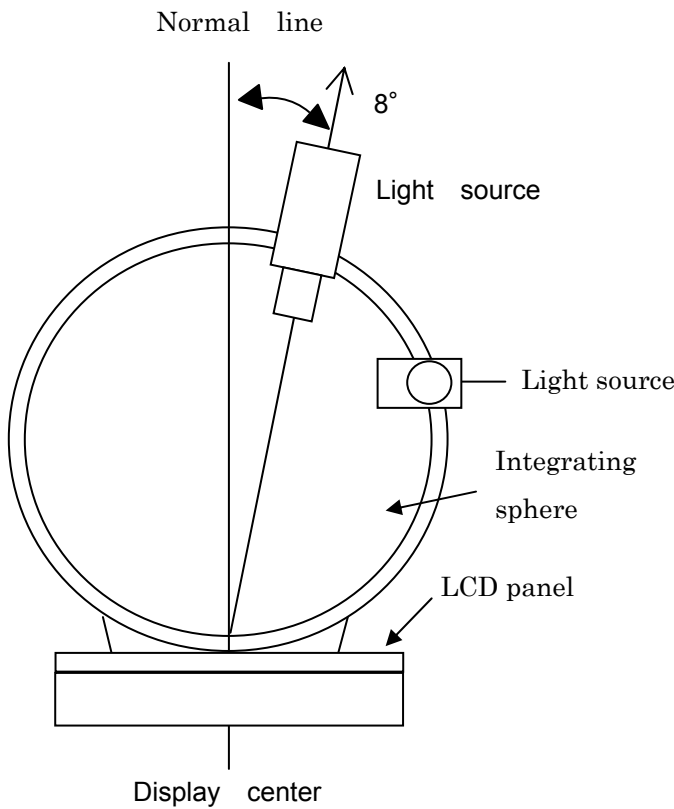

Figure 7-2 Contrast ratio, Reflection ratio, Panel chromaticity

Measurement equipment

(LCD-5200)

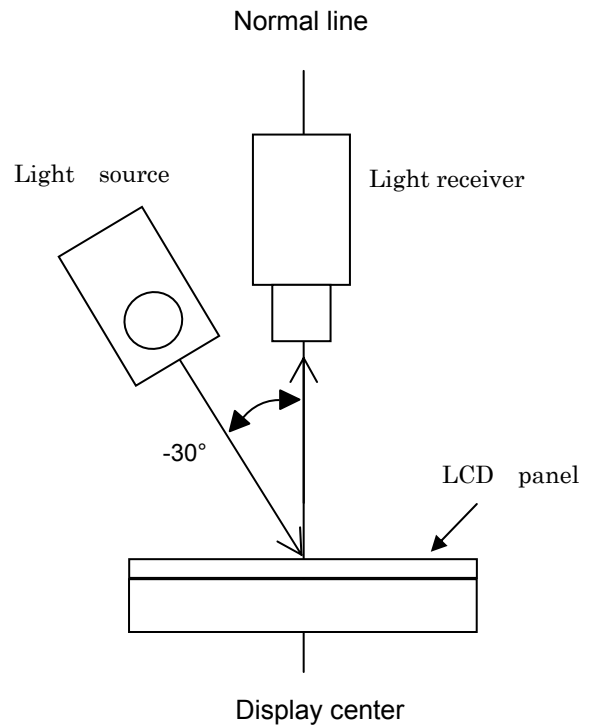

Figure 7-3 Response time

[Note 7-4] Respons time (Change in reflection ratio)

It's difined by the time change of optical receiver output when signal is input to display white or black

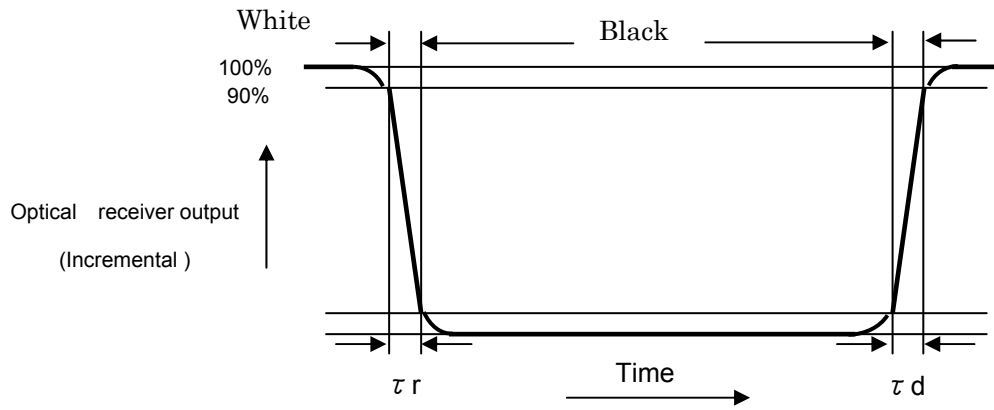

Figure 7-4 Respons time

## 8. Module outline

8-1) Outline dimension of the 1.33" (128 x 128) panel  
The outline dimensions are shown in Figure 8-1 (Page.32)

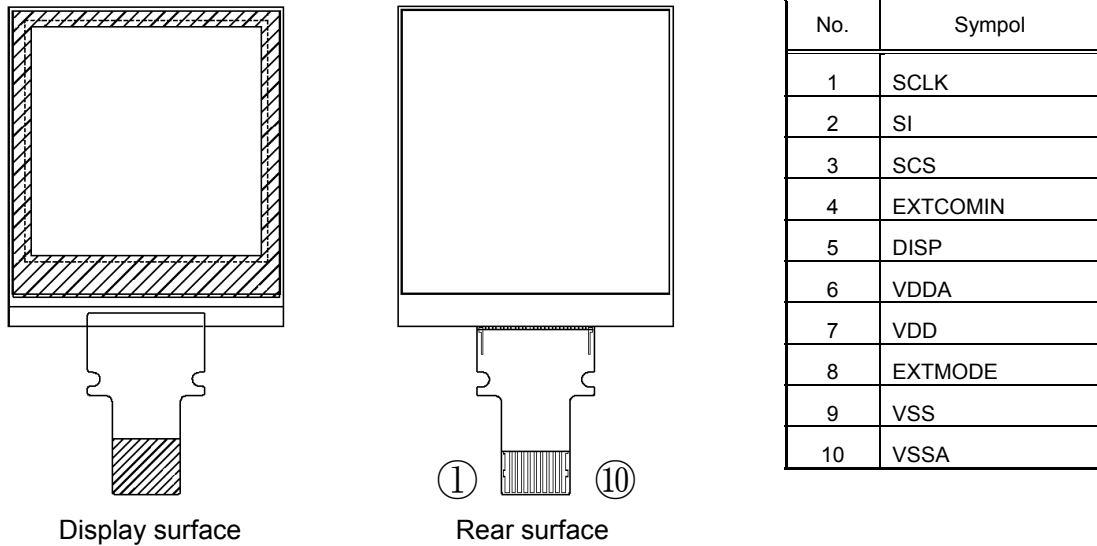

Figure 8-2 Module outline

## 8-2) FPC Bend Specification

Table 8-1 Recommended Connector No.1 ( Bottom side )

Product manufacturer	Series	Part number	Contact
Panasonic	Y5B	AYF531035	Bottom side (Bottom and Upper)
SMK	FP12	CFP-4610-0150F	Bottom side

When bending FPC, bend where specified in Condition (1) and the bend R should be more than R specified in Condition (2). FPC is not to contact glass edge, and there should be no stress to connective area between panel and FPC.

Condition (1) FPC bend recommended area: 0.8mm – 6.0mm from glass edge.

Condition (2) Minimum bend R: Inner diameter R0.45

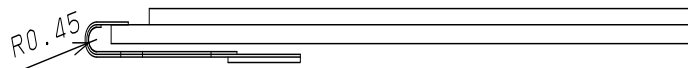

Figure 8-3 FPC Bend Specification

【Note 8-1】 Do not bend backward (toward polarizer film side)

【Note 8-2】 Bend frequency: 3 times or less (Repeat bend condition: 180° ~ 0° )

Table 8-2 Recommended Connector No.2 ( Upper side )

Product manufacturer	Series	Part number	Contact
Panasonic	Y5B	AYF531035	Upper side (Bottom and Upper)
SMK	FP12	CFP-4510-0150F	Upper side

## 9. Display Qualities

Please refer to the outgoing Inspection Standard.

## 10. External capacitors

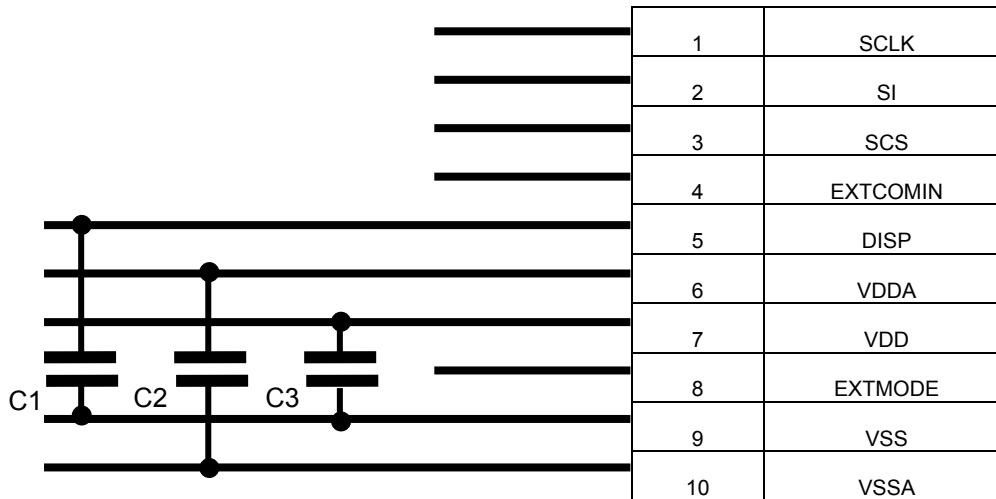

Figure 10-1 External capacitor recommendation capacity value

<Recommended capacity value>

C1: DISP – VSS : rank B 0.1uF Ceramic capacitor

C2: VDDA- VSSA : rank B 1.0uF Ceramic capacitor

C3: VDD – VSS : rank B 1.0uF Ceramic capacitor

※Above circuit and parts are only recommendation.

For actual use, please evaluate their conformity with your system and design.

(Capacitor pressure resistance can be larger than resistance indicated above.)

## 11. Marking

11-1) Displayed by printing. (Ink-jet print)

The display position is shown in Figure. 11-1 Outline dimension diagram.

Display contents

Line 1 → YMDDP  
Line 2 → 01234A

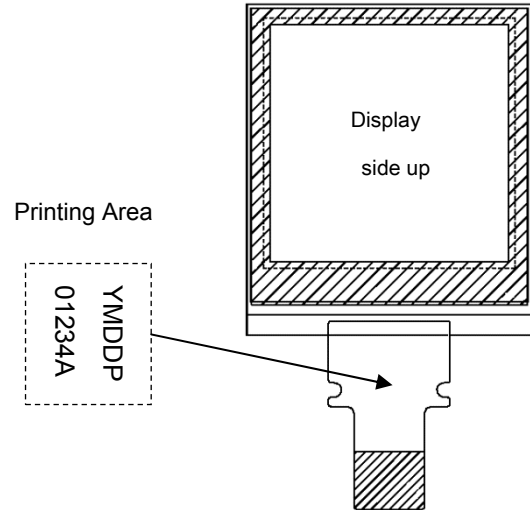

Figure. 11-1 Lot number printing position

Table 11-1 marking line definition

Line	Making	Description
1	YMDDP	Y : Single-digit year (Last digit of the year ) (0,1,- - 8,9) M : Single-digit Month (1,2,-,9,X,Y,Z) DD : Digit of the day (01,-,31) P : Code of manufacture
2	01234A	01234 : Five-digit in Consecutive number (Traceability number) A : Product revision

**12.Packaging form**

## 12-1) Carton storage condition

- 1) Piling number of cartons. : 8
- 2) Package quantity in one carton : 1120 pcs
- 3) Carton size (Typ.) : 528 mm x 363 mm x 228 mm
- 4) Total mess : 6.8kg

(One carton filled with (1120) modules)

## 5) Carton store environment:

## • Temperature:

0~40°C

## • Humidity:

60%RH or lower (at 40°C)

There should be no condensation at low temperature and high humidity.

## • Atmosphere:

No harmful gas, such as acid or alkali, which causes severe corrosion on electronic parts and wiring, are to be detected.

## • Opening the package:

In order to prevent electrostatic damage to TFT modules, room humidity should be made over 50%RH and take effective measure such as use of earth when opening the package.

## • Direct sunlight

Please keep the product in a dark room or cover the product to protect from direct sunlight.

## • Atmospheric condition

Please refrain from keeping the product with possible corrosive gas or volatile flux.

## • Prevention of dew

Do not place directly on the floor, and please store the product carton either on a wooden pallet or a stand to avoid dew condensation. In order to obtain moderate ventilation in the pallet's bottom surfaces, arrange correctly in the fixed direction.

Please place the product cartons away from the storage wall. Be careful of the inside of a warehouse to ventilate well and please consider installation of a ventilator. Manage to rapid temperature change under natural environment.

## • Vibration

Please refrain from keeping the product in the place which always has vibration.

## • Storage Period:

Within above mentioned conditions, maximum storage period should be 3 months



## 12-2) Packaging form figure

The packing condition is shown in Figure. 12-1

The packaging is designed such that the module does not break during transit.

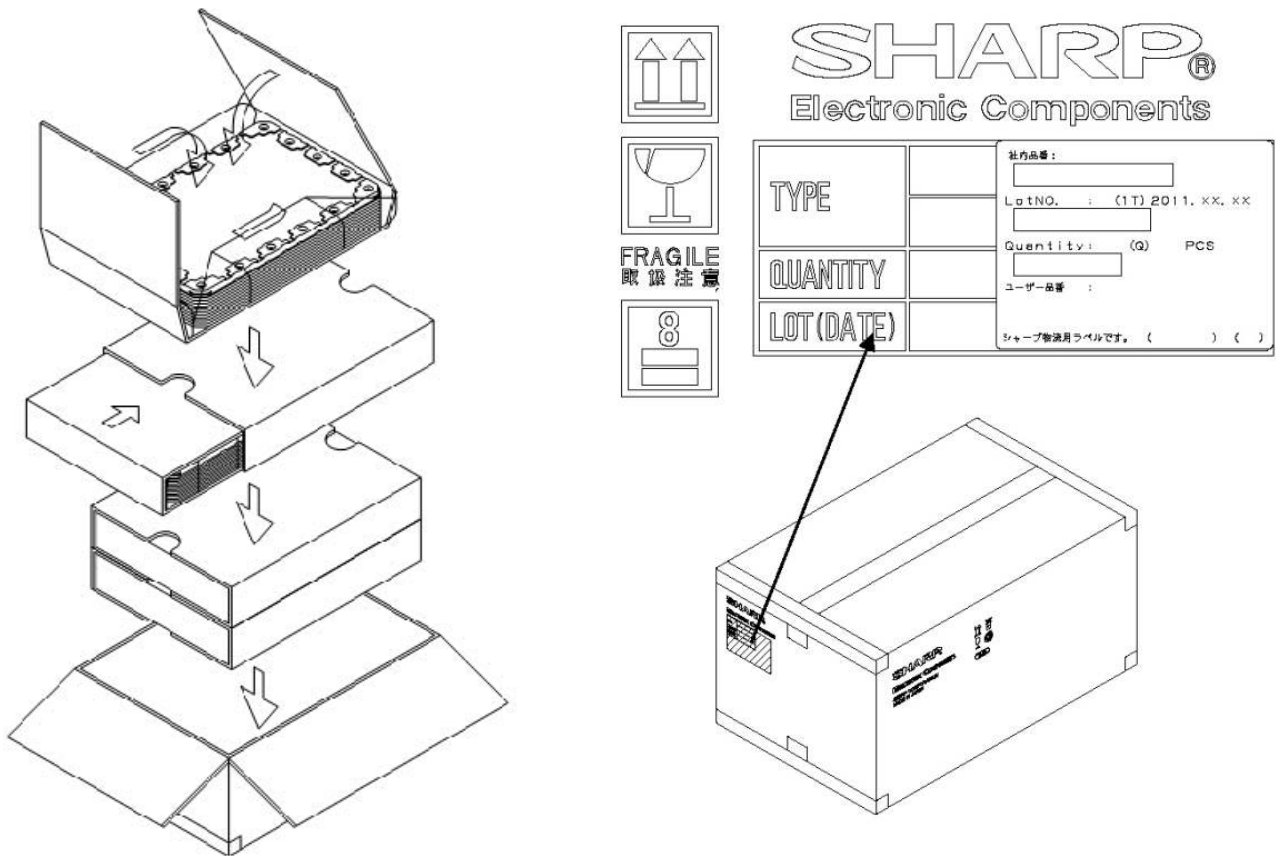

Figure. 12-1 Packaging Form

## 13. Reliability Test Conditions

### 13-1) Reliability Test Items

Table13-1 Reliability Test Items

No.	Test Item	Condition	Remark
1	High temperature storage test (Non operating test)	Ta=80°C                      240h	
2	Low temperature storage test (Non operating test)	Ta=-30°C                      240h ( No condensation )	
3	High temperature and high humidity operating test	Tp=40°C/95%RH              240h	
4	High temperature operating test	Tp=70°C                      240h	
5	Low temperature operating test	Tp=-20°C                      240h	
6	Thermal Shock test (Non operating test)	Ta=-30°C (1h)~+80 °C (1h) / 5 cycle	
7	Electro static discharge test	±200V、200pF(0Ω) each terminal: 1 time (contact mode )	

(Note) Ta = Ambient temperature

    Tp = Panel surface temperature

#### Result Evaluation Criteria

Under the display quality test conditions with normal operation state, these shall be no change which may affect practical display function.

(\*)normal operation state : Temperature:15~35°C, Humidity:45~75%, Atmospheric pressure:86~106kpa)

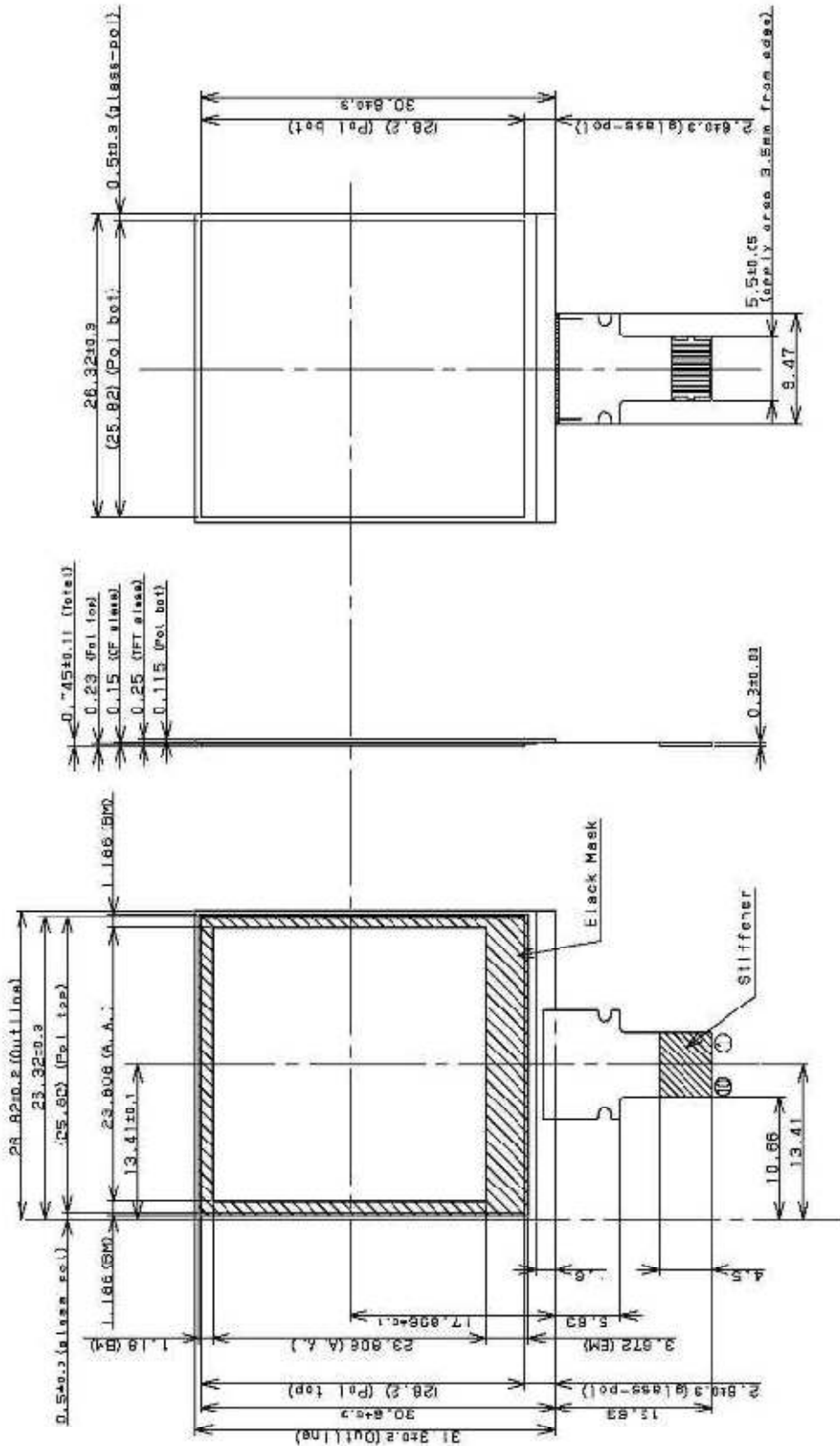

Any foreign materials and contamination outside the Active area are to be treated as "NO-Count" at our inspections. Guarantee of appearance=LCD Active area. General tolerance is J1.2. FPC conc larger than 0.45 in radius. Please design carefully to hide the polarizer and other frame areas, which are outside of the guaranteed area. As the light from backlight may leak from the gap at outside of active area, which are outside of active area. Please pay attentions to such leakage when designing the set. The tolerances of the module which do not include varc of the case.

Figure 8-1 Module outline