

Mechanical Dimensions: Inches [mm]

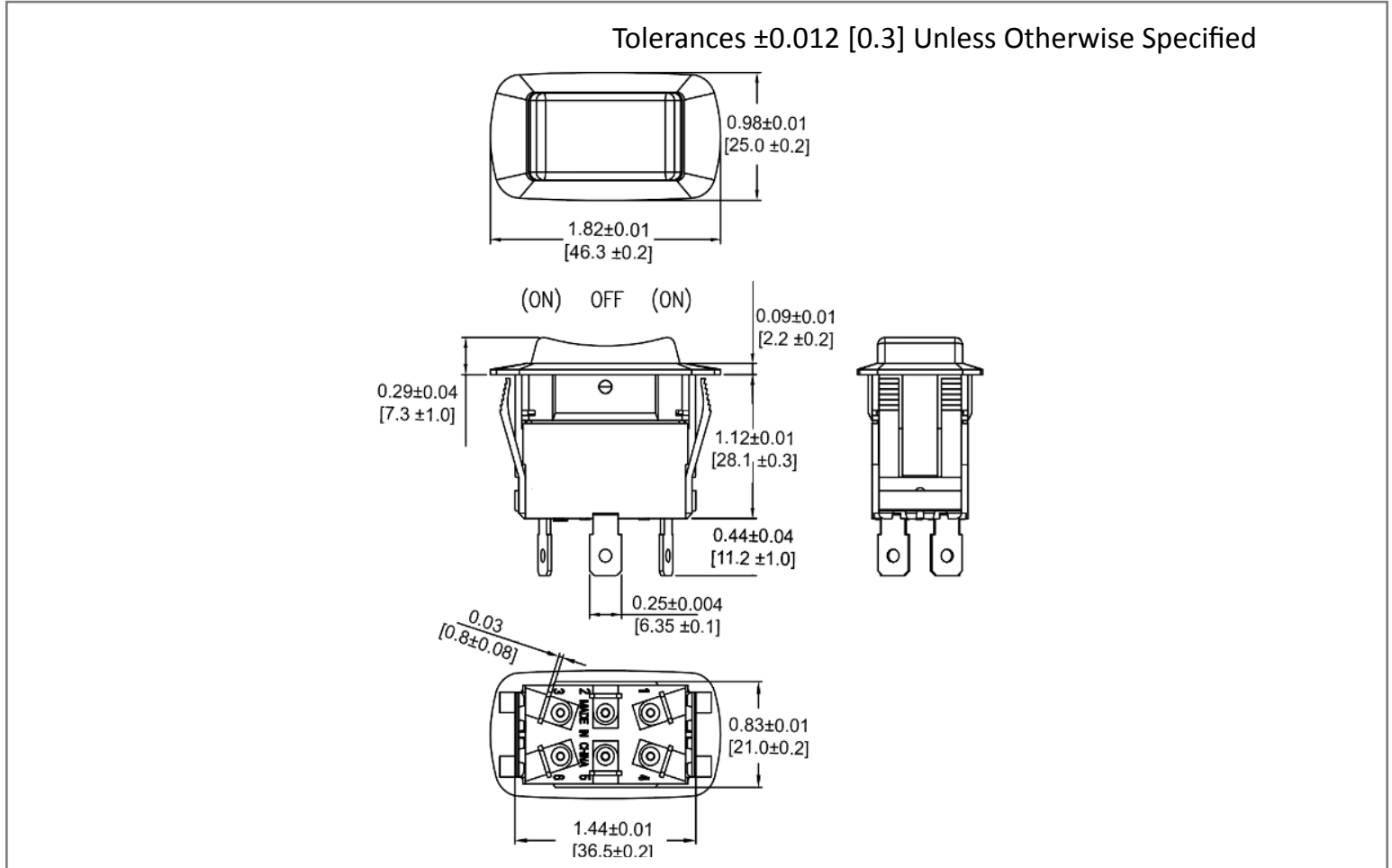

Mounting Hole

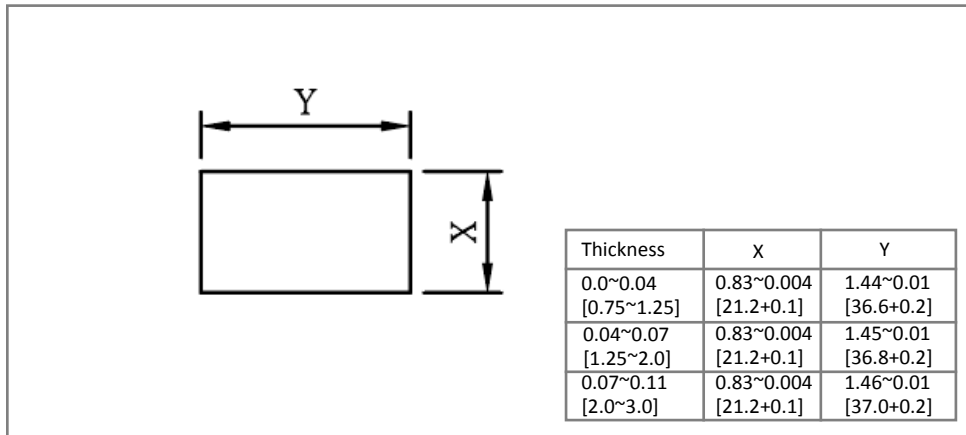

Circuit Diagram

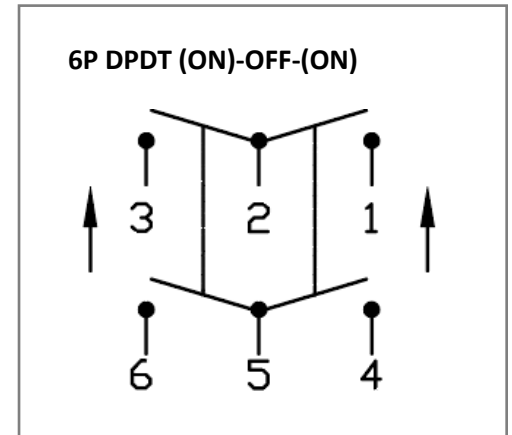

Electrical Specifications

Rating	21A 14V DC, 10A 28V DC	
Contact Resistance	50m ohm Max.	
Insulation Resistance	DC 500V 100M ohm Min.	
Dielectric Strength	AC 1500V 1 minute	
Operation Temperature	-20 °C~85°C	

Material Specifications

Frame	Black, Nylon 66
Actuator	Black, Nylon 66+33%GF
Waterproof	IP56

Rev	Date of issue	Revision Notes	Designed	Approved
B	06-03-2020	Initial Drawing	RC	OF