

LOC		DIST		REVISIONS			
P	F	ZONE	LTR	DESCRIPTION	DATE	APPD	
CH	11		C	ECN 95030204	02/MAR/95	CMS	
			C1	REVISED PER ECO-09-024717	04NOV09	AEG	

1. RETROFIT CONTACT FOR METRIMATE AND AMPLIMITE POWER CONTACT.
  2. WIRE BARREL WILL ACCEPT #12-14 AWG WIRE.
  3. MATES WITH AMP P/N 193535.
- △ OBSOLETE PARTS: OBSOLETE CIS STREAMLINING PER D.RENAUD/D.SINISI

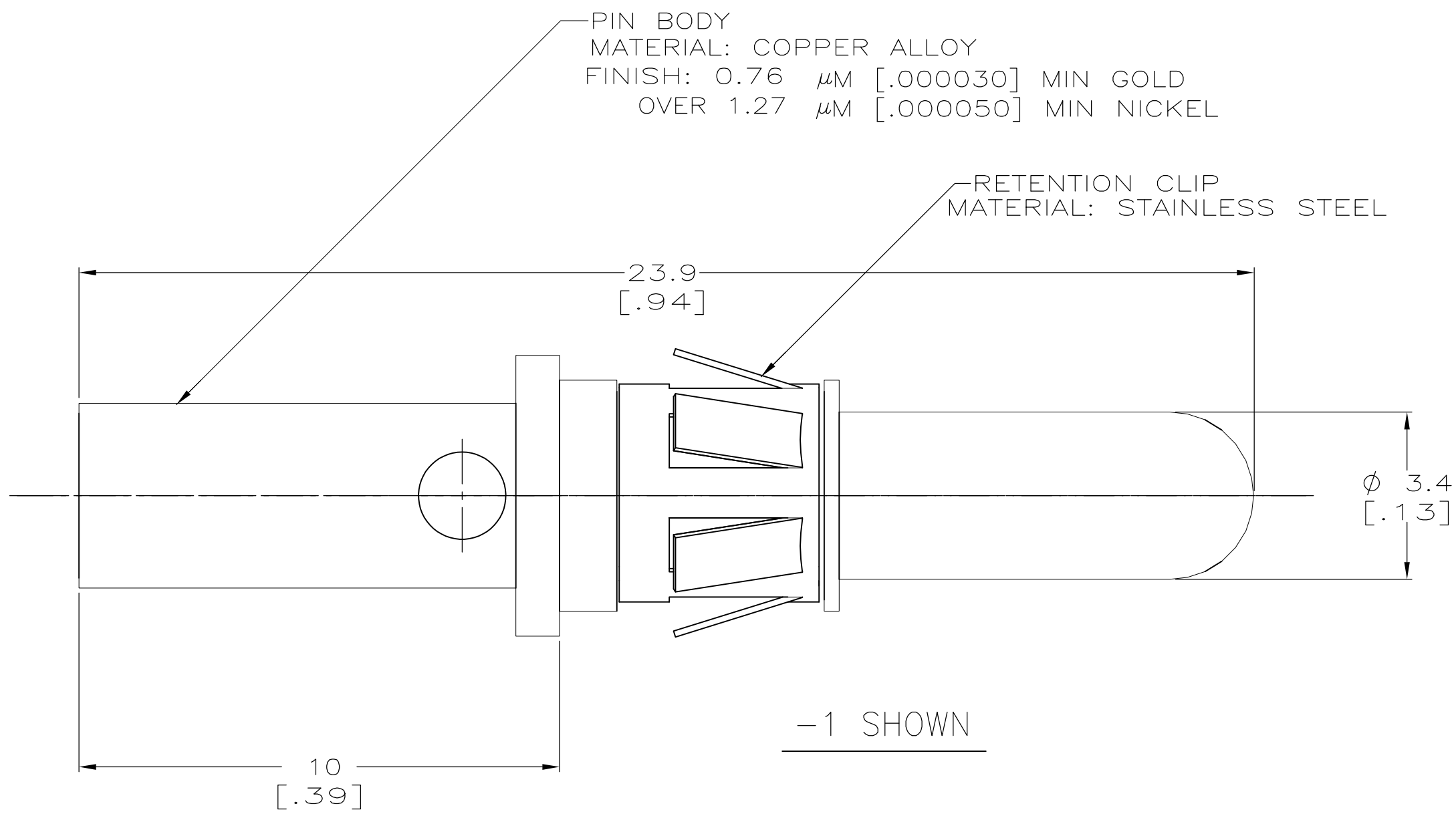
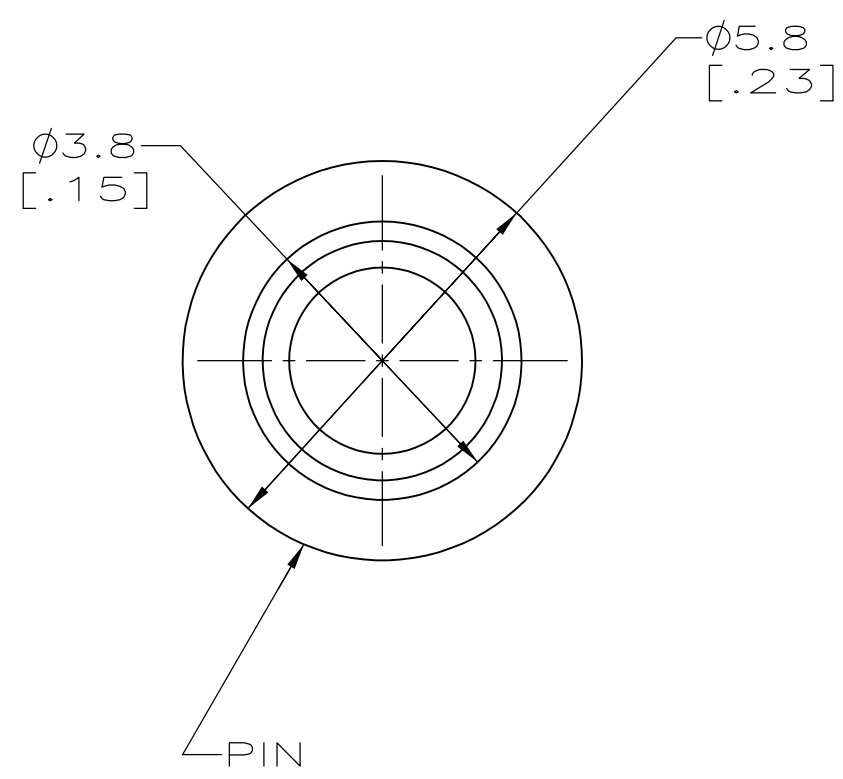

△ OBSOLETE	WITHOUT RET. CLIP	193534-2
	WITH RET. CLIP	193534-1

DO NOT SCALE PRINT. UNLESS SPECIFIED DIMENSIONS IN mm [INCHES] TOLERANCES ON :		DR D. BABOW 06-23-92		AMP Incorporated Harrisburg, PA 17105-3608	
2 PLC DEC ± -		CHK S. SIEGRIST 07-07-92			
3 PLC DEC ± -		APPD D. PETRIE 07-09-92		NAME	
ANGLES ± -		APPD P. GLASER 07-09-92		PIN ASSY, POWER 12-14 AWG	
MATERIAL		PRODUCT SPEC		SIZE	
FINISH		APPLICATION SPEC		CAGE CODE	
WEIGHT		SCALE		DRAWING NO	
				C 00779 C- 193534	
				SHEET 1 OF 1	

THIS DRAWING IS A CONTROLLED DOCUMENT FOR AMP INCORPORATED. IT IS SUBJECT TO CHANGE AND THE CONTROLLING ENGINEERING ORGANIZATION SHOULD BE CONTACTED FOR THE LATEST REVISION.