

## 1. INTRODUCTION

The CERTI-CRIMP II Straight Action Hand Tools are designed to crimp a variety of loose piece terminals.

### NOTE

Refer to <http://tooling.te.com/data.asp> "Documentation" - "CERTI-CRIMP Data Sheets" for a list of loose piece terminals that may be crimped by the CERTI-CRIMP II Straight Action Hand Tool. **The website also contains instructions in various languages.**

### CAUTION

The wire crimper bottoms against the anvil before the CERTI-CRIMP ratchet control releases. This is a design feature that assures maximum electrical and tensile performance of the crimp. Do NOT re-adjust the ratchet.

### 简介

CERTI-CRIMP II 直动式手工具用于压接多种散装端子。

注意: 请登陆 <http://tooling.te.com/data.asp> "Documentation" - "CERTI-CRIMP Data Sheets" 网站以获取可由 CERTI-CRIMP II 直动式手工具压接的端子列表。

注意: 在 CERTI-CRIMP 棘轮释放前, 其压线刀下行至贴住底刀的位置。此设计用于确保压接后能得到最大的电气及拉力性能。棘轮位置不允许调整。

## 1. INTRODUCTION

Les pinces à action directe CERTI-CRIMP II permettent de sertir différents types de cosses en vrac.

### REMARQUE

La liste complète des cosses en vrac sertissables à l'aide de la pince à action directe CERTI-CRIMP II est consultable sur le site <http://tooling.te.com/data.asp> "Documentation" - "CERTI-CRIMP Data Sheets" Ce site comporte également des instructions dans différentes langues.

### ATTENTION

Le poinçon du fil vient en butée contre l'enclume avant le déblocage de la crémaillère CERTI-CRIMP. Cette fonctionnalité permet d'assurer des performances de sertissage optimales tant sur le plan électrique que sur celui de la tenue en traction du fil. NE PAS retoucher au réglage de la crémaillère.

## 1. はじめに

CERTI-CRIMP II ストレートアクション・ハンドツールは、様々なパラ状端子の圧着用に設計されています。

### 注記

それぞれの CERTI-CRIMP II ストレートアクション・ハンドツールで圧着できる端子のリストは、<http://tooling.te.com/data.asp> "Documentation" - "CERTI-CRIMP Data Sheets" でご覧になれます。また、このウェブサイトでは各国の言語に翻訳されているこの取扱説明書をご覧になれます。

### 注意

ツールのラチェットが解除される前に、ワイヤークリンパーがアンビルに突き当たります。この方式により、圧着の電気的および機械的性能を最大限に引き出します。お客様でのラチェットの再調整は、絶対にしないでください。

## 1. EINFÜHRUNG

Die CERTI-CRIMP II Handzange ist dazu vorgesehen, unterschiedliche Klemmen zu crimpen.

### ANMERKUNG

Siehe <http://tooling.te.com/data.asp> "Documentation" - "CERTI-CRIMP Data Sheets" für eine Aufstellung von LP-Kontakte, die mit der CERTI-CRIMP Handzange gecrimpt werden können. Die Website enthält auch Anleitungen in verschiedenen Sprachen.

### VORSICHT

Das Werkzeugoberteil fährt immer auf Block mit den Amboß, bevor die CERTI-CRIMP Handzange die Ratsche freigibt. Dies ist ein Konstruktionsmerkmal, welches maximale Verpressung und Zugfestigkeit des Crimp-Kontaktes gewährleistet. Die Ratsche darf nicht verstellt werden.

## 1. INTRODUZIONE

Gli attrezzi manuali CERTI-CRIMP II Straight Action sono progettati per aggraffare vari tipi di terminali sciolti.

### NOTA

Per la lista dei terminali sciolti che possono essere aggraffati con l'attrezzo manuale CERTI-CRIMP II Straight Action, consultare il sito multilingua <http://tooling.te.com/data.asp> "Documentation" - "CERTI-CRIMP Data Sheets".

### ATTENZIONE

Prima del rilascio del cricchetto, la matrice di aggraffatura è appoggiata sull'incudine. Tale condizione garantisce prestazioni ottimali dell'aggraffatura in termini di elettricità e tensione. NON modificare la regolazione del cricchetto.

**PROPER USE GUIDELINES**

Cumulative Trauma Disorders can result from the prolonged use of manually powered hand tools. Hand tools are intended for occasional use and low volume applications. A wide selection of powered application equipment for extended-use, production operations is available.

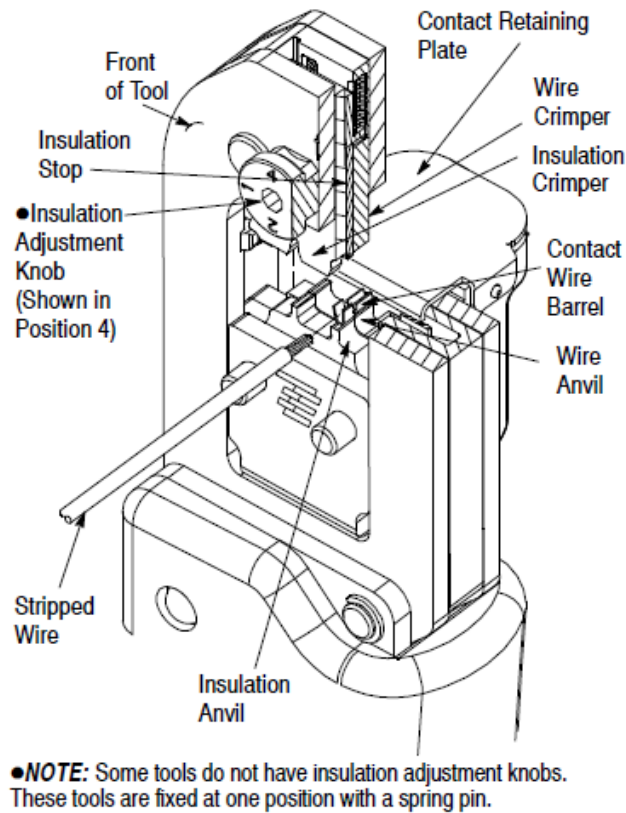

Figure 1

**2. DESCRIPTION**

The FRONT of the tool is marked with the tool part number, wire size ranges, and crimp height specification.

The tool features a fixed die (crimper), a movable die (anvil), an insulation stop, a CERTI-CRIMP hand crimping tool ratchet control, and a flip locator. Many tools feature an insulation adjustment knob which is used to regulate the crimp height of the contact insulation barrel during the crimping operation. See paragraph 3.2. in this instruction sheet for details on the use of the adjustment knob. The flip locator is a feature used to locate the contact in the crimp tooling. The insulation stop will limit the insertion distance of the stripped wire into the contact. In use, the insulation stop rests in the slot of the contact. (See Figures 1 and 2.) The CERTI-CRIMP hand crimping tool ratchet control ensures full crimping of the contact. Once engaged, the ratchet will not release until the dies have been fully closed.

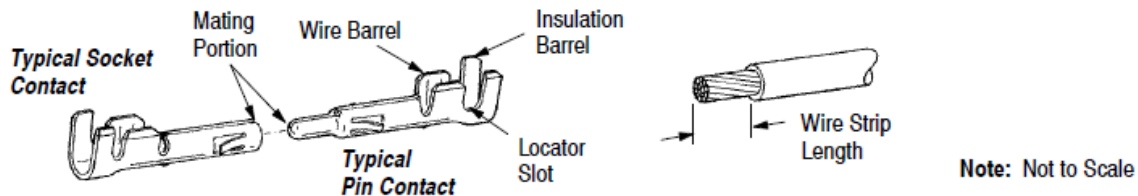

Figure 2

### 3. CRIMPING PROCEDURE

Refer to the table at <http://tooling.te.com/data.asp> to ensure that the wire intended for use is compatible with the wire size and insulation diameter specified in the table. Strip the wire to the length indicated in the table.



**CAUTION**

*Do NOT cut or nick the wire strands during wire stripping.*

#### 3.1. Proceed as follows:

1. Hold the tool so that the FRONT side is facing you.
2. Ensure that the tool ratchet is released by squeezing the tool handles and allowing them to open FULLY.
3. Be sure the flip locator is in the load position (see Figure 3). Hold the contact by the wire and insulation barrel, push the contact retaining plate and insert the contact receptacle into the flip locator so that the top of the contact (opening for the wire) faces away from the tool. Be sure to insert the contact in the proper nest according to the wire size on the front of the tool. Once the contact is loaded, release the contact retaining plate and flip the locator up 90 degrees.

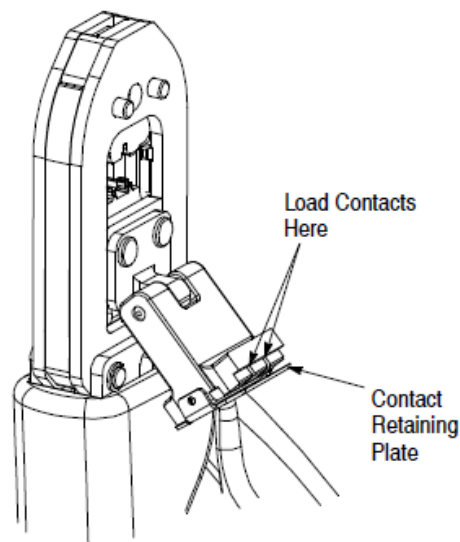

Figure 3

4. Squeeze the tool handles together until the insulation anvil starts entry into the insulation crimper (usually two ratchet clicks). Do NOT deform the insulation barrel or wire barrel.
5. Insert a properly stripped wire through the insulation stop slot and into the wire barrel of the contact until the insulation butts against the insulation stop.
6. Holding wire in place, crimp contact to the wire by squeezing the tool handles together until the ratchet releases.
7. Allow tool handles to open FULLY. Depress the Contact Retaining Plate and remove the contact.

#### 3.2. Insulation Adjustment Procedure

On many tools, the insulation barrel crimp height is regulated by the insulation adjustment knob (see Figure 1). The insulation crimp should hold the insulation firmly without cutting into the insulation.

To determine the proper insulation crimp setting, test crimp a loose piece contact using the setting which corresponds to the insulation diameter: (1) small; (2) and (3) medium; or (4) large. If the crimped insulation barrel is too tight or loose, change the setting by pulling out and rotating the adjustment knob to the desired setting.

## 4. MAINTENANCE AND INSPECTION PROCEDURE

It is recommended that a maintenance and inspection program be performed periodically to ensure dependable and uniform terminations. Frequency of inspection depends on:

- The care, amount of use, and handling of the hand tool,
- The presence of abnormal amounts of dust and dirt,
- The degree of operator skill, and
- Your own established standards.

The hand tool is inspected before being shipped; however, it is recommended that the tool be inspected immediately upon its arrival at your facility to ensure that the tool has not been damaged during shipment.

### 4.1. Daily Maintenance

1. Remove dust, moisture, and other contaminants with a clean brush, or a soft, lint-free cloth. Do NOT use objects that could damage the tool.
2. Make certain that the retaining pins are in place and that they are secured with retaining rings (see Figure 5).
3. All pins, pivot points, and bearing surfaces should be protected with a thin coat of any good SAE 20 oil. Do not oil excessively.
4. When the tool is not in use, keep handles closed to prevent objects from becoming lodged in the crimping jaws. Store the tool in a clean, dry area.

### 4.2. Lubrication

Lubricate all pins, pivot points, and bearing surfaces with SAE 20 oil as follows:

- Tools used in daily production: lubricate daily
- Tools used daily (occasional): lubricate weekly
- Tools used weekly: lubricate monthly

Wipe excess oil from tool, particularly from crimping area. Oil transferred from the crimping area onto certain terminations may affect the electrical characteristics of an application.

### 4.3. Periodic Inspection

1. Hand tool may be immersed (handles partially closed) in a reliable commercial degreasing compound (suitable for plastics) to remove accumulated dirt, grease and foreign matter.
2. Close tool handles until ratchet releases and then allow them to open freely. If they do not open quickly and fully, the spring is defective and must be replaced (see Section 5; REPLACEMENT and REPAIR).
3. Inspect head assembly for worn, cracked, or broken jaws. If damage is evident, return it for evaluation and repair.

### 4.4. Crimp Height Inspection

This inspection requires the use of micrometer with a modified anvil as shown in Figure 4.

Crimp height inspection is performed by means of a micrometer with a modified anvil, commonly referred to as a crimp-height comparator.

TE Connectivity does not manufacture or market crimp-height comparators. Detailed information on obtaining and using crimp-height comparators can be found in Instruction Sheet [408-7424](#).

A recommended Crimp Height Comparator is RS-1019-5LP, Crimp Height Comparator 3-576692-6 is recommended in Great Britain; Crimp Height Comparator 675836-0 and -1 are recommended in Germany (see Table 1).

Part Number	Description	Manufacturer	Reference Number
3-576692-6	Digital Readout Imperial/Metric 0-1 Inch/0-25.4 mm/	Mitutoyo Corp., Japan	342-431-30
675836-0, -1	Mechanical Readout Metric 0-25 mm		112-401

Table 1

Proceed as follows:

1. Select a contact and a wire (maximum size) for each crimp section listed in the appropriate table at <http://tooling.te.com/data.asp>.
2. Refer to Section 3; CRIMPING PROCEDURE, and crimp the contact(s).
3. Using a crimp height comparator, measure wire barrel crimp height as shown in Figure 4. If the crimp height conforms to that marked on the tool, the tool is considered dimensionally correct. If not, return the tool to TE for evaluation and repair (refer to Section 5; REPLACEMENT and REPAIR).

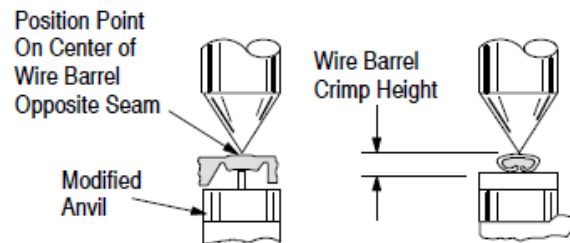

Figure 4

#### 4.5. CERTI-CRIMP Ratchet Control Inspection

The CERTI-CRIMP ratchet control feature on these hand tools should be checked to ensure that the ratchet does not release prematurely, allowing the crimping dies to open before they have fully bottomed. Obtain a 0.025 mm [.001 in.] shim that is suitable for checking the clearance between the bottoming surfaces of the crimping dies. Proceed as follows:

1. Select the maximum size wire and strip it according to dimensions listed in the drawing shipped with the tool.
2. Select contact and crimp section corresponding to the selected wire size (refer to the drawing shipped with the tool).
3. Position the contact and wire in the crimping dies, as described in Section 3: CRIMPING PROCEDURE.
4. Hold the wire in place and squeeze the handles until the CERTI-CRIMP ratchet control releases. Hold the handles in this position, maintaining just enough tension to keep the dies closed.
5. Check the clearance between the bottoming surfaces of the wire crimper and the wire anvil (see Figure 1). If the clearance is 0.025 mm [.001 in.] or less (on at least two of the bottoming surfaces), the ratchet is satisfactory. If clearance exceeds 0.025 mm [.001 in.], the ratchet is out of adjustment and must be repaired. See Section 5; REPLACEMENT and REPAIR.



**NOTE**

*The insulation crimper does not bottom on the insulation anvil.*

### 5. REPLACEMENT AND REPAIR

Replacement parts are listed in Figure 5. Parts other than those listed in Figure 5 should be replaced by TE to ensure quality and reliability of the tool. Order replacement parts through your TE Representative or call 1-800-526-5142.

Tools may also be returned for evaluation and repair. For tool repair service, contact a TE Representative at: 1-800-526-5136.

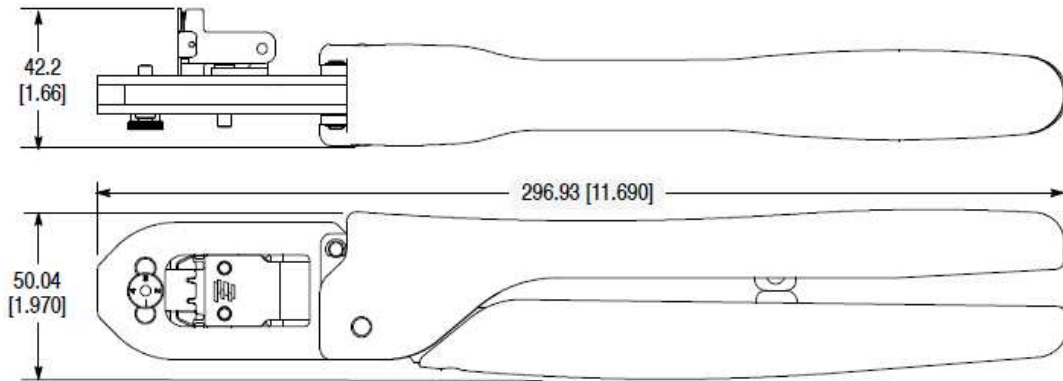

**NOTE:** Closed to Last Ratchet Point Before Release

Replaceable Parts			
Item	Part Number	Description	Qty Per Tool
1	21045-3	Ring, Retaining	4

Figure 5

### 6. REVISION SUMMARY

- Removed word “precisely” from Section 2
- Updated to current corporate logo.
- Revised formatting throughout; which included some paragraph re-structuring, moving (and re-numbering) of some figures and the creation of Table 1.