

Angle Sensor

GMR-Based Angular Sensor
for Rotor-Position Sensing

TLE5012

TLE5012-E0318
TLE5012-E0742

Data Sheet

V 1.0, 2010-11
Final

Edition 2010-11

**Published by
Infineon Technologies AG
81726 Munich, Germany**

**© 2011 Infineon Technologies AG
All Rights Reserved.**

Legal Disclaimer

The information given in this document shall in no event be regarded as a guarantee of conditions or characteristics. With respect to any examples or hints given herein, any typical values stated herein and/or any information regarding the application of the device, Infineon Technologies hereby disclaims any and all warranties and liabilities of any kind, including without limitation, warranties of non-infringement of intellectual property rights of any third party.

Information

For further information on technology, delivery terms and conditions and prices, please contact the nearest Infineon Technologies Office (www.infineon.com).

Warnings

Due to technical requirements, components may contain dangerous substances. For information on the types in question, please contact the nearest Infineon Technologies Office.

Infineon Technologies components may be used in life-support devices or systems only with the express written approval of Infineon Technologies, if a failure of such components can reasonably be expected to cause the failure of that life-support device or system or to affect the safety or effectiveness of that device or system. Life support devices or systems are intended to be implanted in the human body or to support and/or maintain and sustain and/or protect human life. If they fail, it is reasonable to assume that the health of the user or other persons may be endangered.

TLE5012 GMR-Based Angular Sensor

Revision History: 2010-11, V 1.0

Previous Version: -

Page	Major changes since last revision
general	correction of typing errors

We Listen to Your Comments
 Any information within this document that you feel is wrong, unclear or missing at all?
 Your feedback will help us to continuously improve the quality of this document.
 Please send your proposal (including a reference to this document) to:
sensors@infineon.com

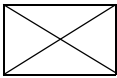

Table of Contents

	Table of Contents	4
	List of Figures	6
	List of Tables	7
1	Product Description	8
1.1	Overview	8
1.2	Features	9
1.3	Typical Applications	9
2	Functional Description	10
2.1	General	10
2.2	Pin Configuration	12
2.3	Pin Description	12
2.4	Block Diagram	13
2.5	Functional Block Description	13
2.5.1	Internal Power Supply	13
2.5.2	Oscillator and PLL	13
2.5.3	SD-ADCs	13
2.5.4	Digital Signal Processing Unit	14
2.5.5	Interfaces	14
2.5.6	Safety Features	14
3	Specifications	15
3.1	Application Circuit	15
3.2	Absolute Maximum Ratings	18
3.3	Operating Range	18
3.4	Characteristics	20
3.4.1	Electrical Parameters	20
3.4.2	ESD Protection	21
3.4.3	GMR Parameters	22
3.4.4	Angle Performance	23
3.4.5	Signal Processing	23
3.4.6	Clock Supply (CLK Timing Definition)	26
3.5	Interfaces	27
3.5.1	Synchronous Serial Communication (SSC) Interface	27
3.5.1.1	SSC Timing Definition	28
3.5.1.2	SSC Data Transfer	30
3.5.1.3	Registers	33
3.5.1.3.1	TLE5012 Register	34
3.5.1.4	Communication Examples	50
3.5.2	Pulse-Width Modulation Interface	51
3.5.3	Hall Switch Mode	53
3.5.4	Incremental Interface	55
3.6	Test Structure	57
3.6.1	ADC Test Vectors	57
3.7	Overvoltage Comparators	59
3.7.1	Internal Supply Voltage Comparators	59
3.7.2	V _{DD} Overvoltage Detection	59
3.7.3	GND - Off Comparator	59
3.7.4	V _{DD} - Off Comparator	60

Table of Contents

4	Package Information	61
4.1	Package Parameters	61
4.2	Package Outline	61
4.3	Footprint	62
4.4	Packing	62
4.5	Marking	63

List of Figures

Figure 1	Sensitive bridges of the GMR sensor	10
Figure 2	Theoretical output of the GMR sensor bridges	11
Figure 3	Pin configuration (top view)	12
Figure 4	TLE5012 block diagram	13
Figure 5	PRO-SIL™ Logo	14
Figure 6	Application circuit for TLE5012 with SSC and PWM Interface (using internal CLK)	15
Figure 7	Application circuit for TLE5012 with HS Mode (using internal CLK)	16
Figure 8	Application circuit for TLE5012 with SSC Interface and IIF (using external CLK)	16
Figure 9	Application circuit for TLE5012 with only PWM Interface (using internal CLK)	17
Figure 10	Operating magnetic induction	19
Figure 11	Offset and amplitude definition	22
Figure 12	TLE5012 signal path	24
Figure 13	Delay of sensor output	25
Figure 14	External CLK timing definition	26
Figure 15	SSC configuration in sensor-slave mode with push-pull outputs (high speed application)	27
Figure 16	SSC configuration in sensor-slave mode and open drain (safe bus systems)	28
Figure 17	SSC timing	28
Figure 18	SSC data transfer (data-read example)	30
Figure 19	SSC data transfer (data-write example)	30
Figure 20	SSC bit ordering (read example)	32
Figure 21	Fast CRC polynomial division circuit	32
Figure 22	Typical Example for a PWM Signal	51
Figure 23	Hall Switch Mode	53
Figure 24	HS hysteresis	55
Figure 25	Incremental Interface with Step/Direction mode	55
Figure 26	Incremental Interface Protocol with symbolic illustration of SPI Interface	56
Figure 27	IIF index coding	56
Figure 28	ADC test vectors	58
Figure 29	OV comparator	59
Figure 30	GND - Off comparator	60
Figure 31	V _{DD} - Off comparator	60
Figure 32	PG-DSO-8 package dimensions	61
Figure 33	Position of sensing element	62
Figure 34	Footprint of PG-DSO-8	62
Figure 35	Tape and Reel	62

List of Tables

Table 1	Pin description	12
Table 2	Absolute maximum ratings	18
Table 3	Operating range	18
Table 4	Electrical parameters	20
Table 5	Electrical parameters for $4.5V < V_{DD} < 5.5V$	20
Table 6	Electrical parameters for $3.0V < V_{DD} < 3.6V$	21
Table 7	ESD protection	21
Table 8	Basic GMR parameters	22
Table 9	Angle performance	23
Table 10	Signal processing	24
Table 11	CLK timing specification	26
Table 12	PAD characteristics	27
Table 13	SSC push-pull timing specification	28
Table 14	SSC open-drain timing specification	29
Table 15	Structure of the Command Word	30
Table 16	Structure of the Safety Word	31
Table 17	Bit types	31
Table 18	Registers Overview	33
Table 19	SSC command to read the angle value	50
Table 20	SSC command to read angle speed and angle revolution	50
Table 21	SSC command to change Interface Mode2 register	50
Table 22	PWM Interface	51
Table 23	Hall Switch Mode	53
Table 24	Incremental Interface	56
Table 25	ADC Test Vectors	57
Table 26	SSC command to enable ADC test vector check	58
Table 27	Structure of Write Data for some different test vectors	58
Table 28	Test comparators	59
Table 29	Package parameters	61

1 Product Description

1.1 Overview

The TLE5012 is a 360° angle sensor that detects the orientation of a magnetic field by measuring sine and cosine angle components with monolithic integrated Giant Magneto Resistance (iGMR) elements.

Highly precise angle values are maintained at various temperatures throughout the device's lifetime using an internal autocalibration algorithm.

Data communications are accomplished with a bi-directional Synchronous Serial (SSC)-Interface that is Serial Peripheral Interface (SPI)-compatible.

The absolute angle value and other values are transmitted via SSC or via a Pulse-Width Modulation (PWM) protocol. The sine and cosine raw values can also be read out. These raw signals are digitally processed internally to calculate the angle orientation of the magnetic field (magnet).

The TLE5012 is a precalibrated sensor. The calibration parameters are stored in laser fuses. At start-up, the values of the fuses are written into flip-flops, where these values can be changed by the application-specific parameters. The TLE5012-E0318 and TLE5012-E0742 are especially configured in a Hall-Switch emulation mode for motors with three or seven pole pairs.

Online diagnostic functions are provided to ensure reliable operation.



Product Type	Marking	Ordering Code	Package
TLE5012	5012	SP000477068	PG-DSO-8
TLE5012-E0318	5012E03	SP000611246	PG-DSO-8
TLE5012-E0742	5012E07	SP000611250	PG-DSO-8

1.2 Features

- GMR-based principle
- Integrated magnetic field sensing for angle measurement
- Fully calibrated 0 - 360° angle measurement with revolution counter and angle speed measurement
- Two separate highly accurate single-bit SD-ADCs
- 15-bit representation of absolute angle value on the output (resolution of 0.01°)
- 16-bit representation of sine/cosine values on the interface
- Max. 1.0° angle error over lifetime and temperature with activated auto-calibration
- Bi-directional SSC Interface up to 8 Mbit/s
- Supports Safety Integrity Level (SIL) with diagnostic functions and status information
- Interfaces: SSC, PWM, Incremental Interface (IIF), Hall-Switch Mode (HSM)
- 0.25- μ m CMOS technology
- Automotive qualified: -40°C to 150°C (junction temperature)
- ESD > 4 kV (HBM)
- RoHS-compliant (Pb-free package)

1.3 Typical Applications

The TLE5012 GMR-Based Angular Sensor is designed for angular position sensing in automotive applications, such as:

- Electrical commutated motor (e.g. used in Electric Power Steering (EPS))
- Rotary switch
- Steering angle
- General angular sensing

2 Functional Description

2.1 General

The GMR sensor uses vertical integration. This means that the GMR-sensitive areas are integrated above the logic portion of the TLE5012 device. These GMR elements change their resistance depending on the direction of the magnetic field.

Four individual GMR elements are connected to one Wheatstone sensor bridge. These GMR elements sense one of two components of the applied magnetic field:

- X component, V_x (cosine) or the
- Y component, V_y (sine)

The advantage of a full-bridge structure is that the amplitude of the GMR signal is doubled and temperature effects cancel out each other.

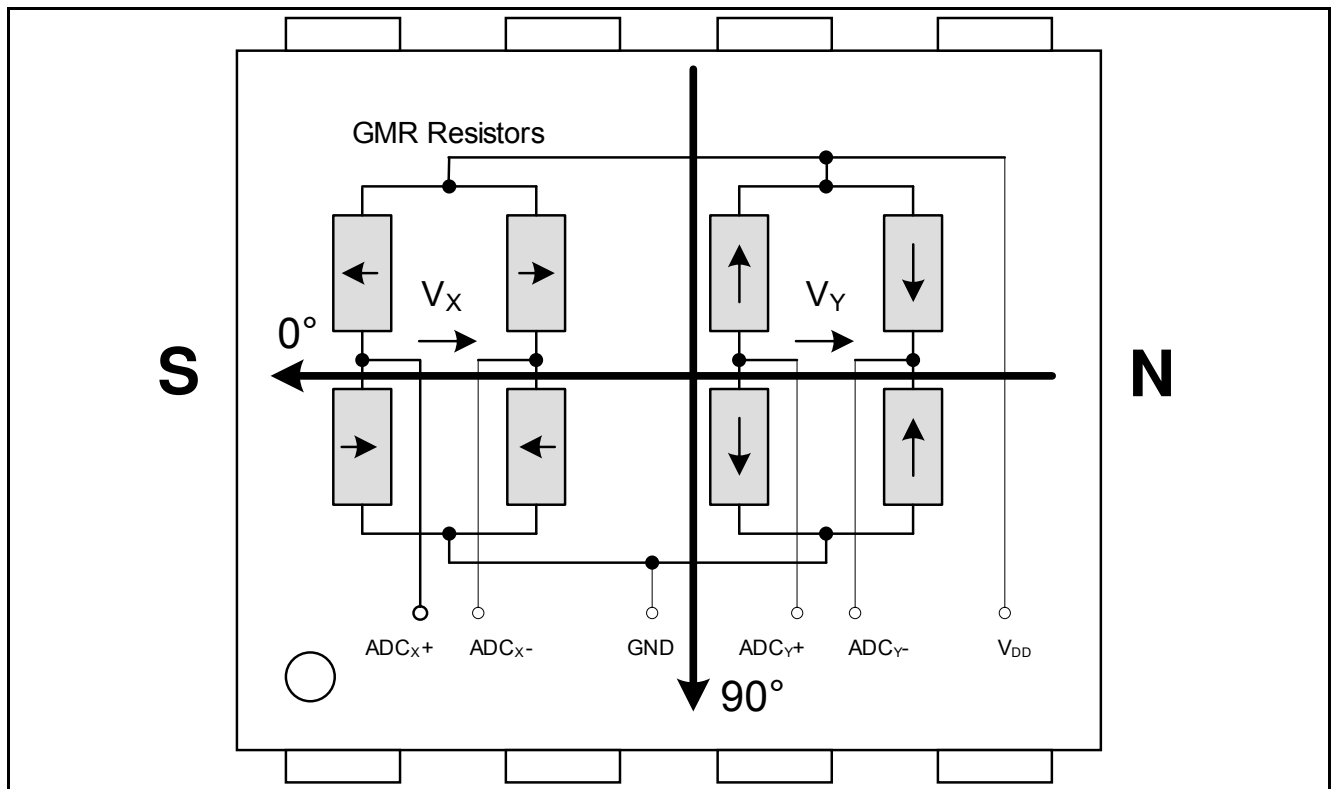

Figure 1 Sensitive bridges of the GMR sensor

*Note: In **Figure 1**, the arrows in the resistors represent the magnetic direction which is fixed in the Reference Layer. If the external magnetic field is parallel to the direction of the Reference Layer, the resistance is minimal. If they are anti-parallel, resistance is maximal.*

The output signal of each bridge is only unambiguous over 180° between two maxima. Therefore two bridges are oriented orthogonally to each other to measure 360°.

With the trigonometric function ARCTAN, the true 360° angle value can be calculated, based on the relationship of X and Y signals.

Because only the relative values influence the result, the absolute magnitude of the two signals is of minor importance. Therefore, it is possible to compensate for most external influences on the amplitudes.

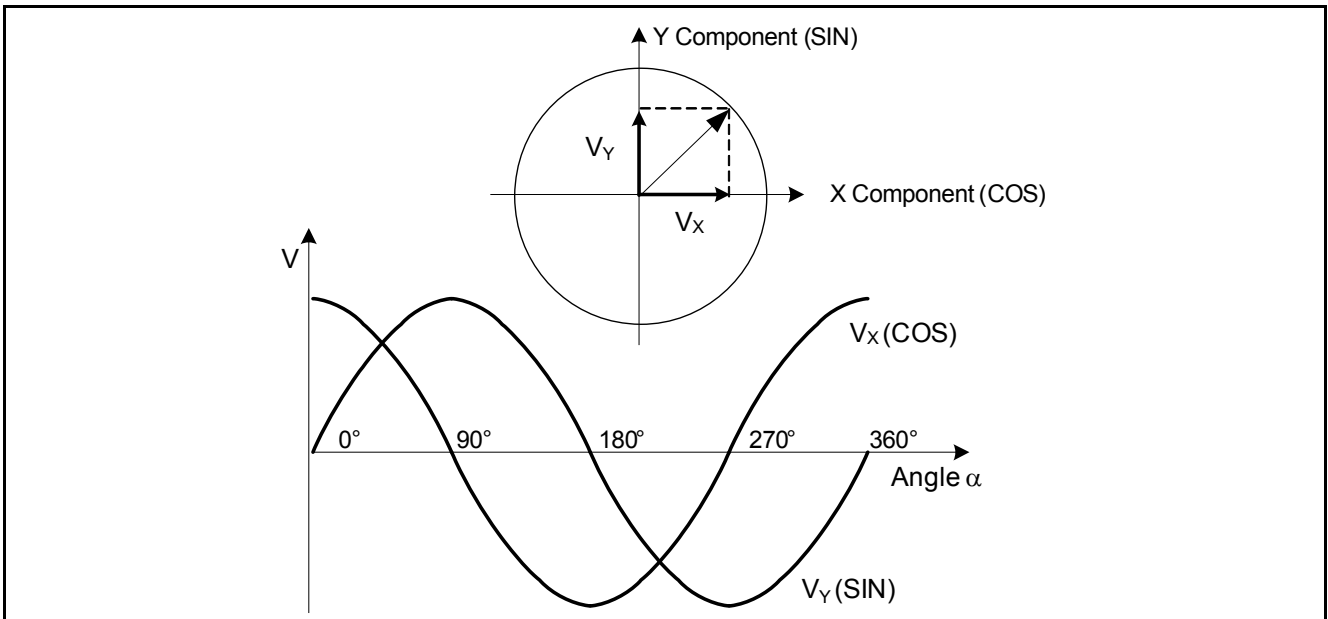

Figure 2 Theoretical output of the GMR sensor bridges

2.2 Pin Configuration

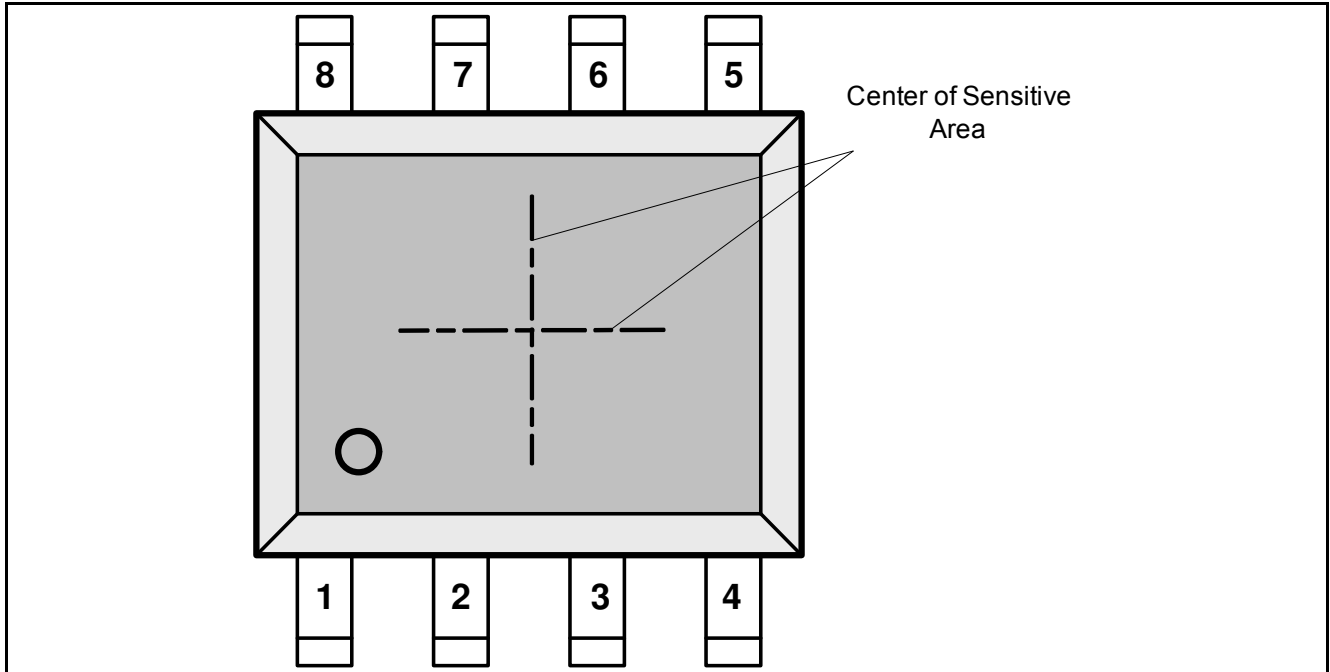

Figure 3 Pin configuration (top view)

2.3 Pin Description

Table 1 Pin description

Pin No.	Symbol	In/Out	Function
1	CLK	I	External Clock (selection of interface) ¹⁾
2	SCK	I	SSC Clock
3	CSQ	I	SSC Chip Select
4	DATA (DATA / IIF_Index / HS3)	I/O	Interface DATA: SSC DATA; IIF Index; Hall Switch signal 3 ²⁾
5	IFA (IIF_A / HS1 / PWM)	O	Interface A: IIF phase A; Hall Switch signal 1; PWM ²⁾
6	V _{DD}	-	Supply voltage
7	GND	-	Ground
8	IFB (IIF_B / HS2)	O	Interface B: IIF phase B; Hall Switch signal 2 ²⁾

1) Connected to V_{DD} --> Incremental Interface is used; connected to GND--> Interface in IF_MD is used; sampling within Power-On Time; interface change within operation via SSC IF possible

2) Depends on external circuit of CLK and IF_MD setting

2.4 Block Diagram

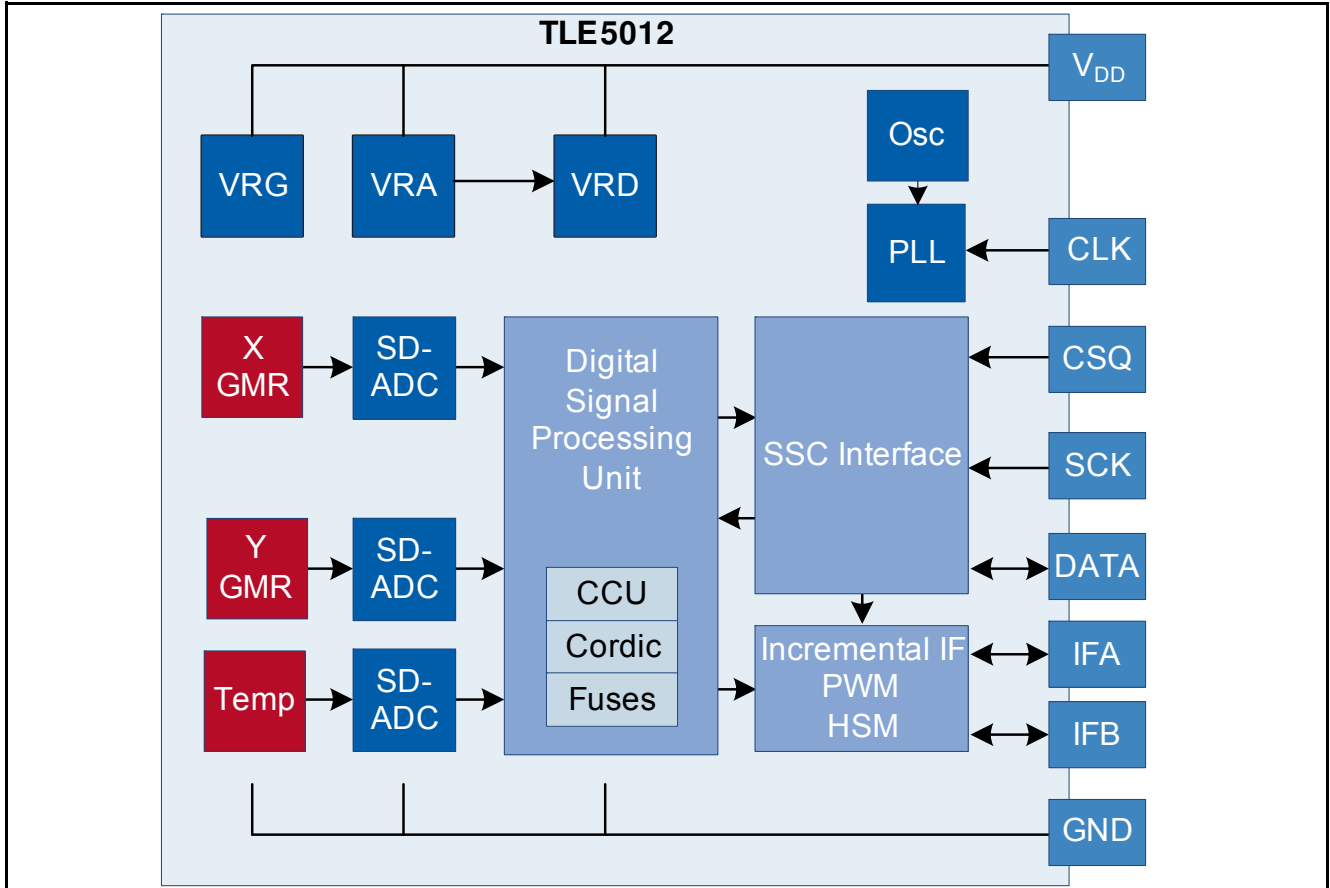

Figure 4 TLE5012 block diagram

2.5 Functional Block Description

2.5.1 Internal Power Supply

The internal stages of the TLE5012 have different voltage regulators.

- GMR Voltage Regulator VRG
- Analog Voltage Regulator VRA
- Digital Voltage Regulator VRD (derived from VRA)

These regulators are directly connected to the supply voltage V_{DD} .

2.5.2 Oscillator and PLL

The internal frequency oscillator feeds the Phase-Locked Loop (PLL). Therefore the external CLock (CLK) can also be used.

2.5.3 SD-ADCs

The SD-ADCs transform the analog GMR voltages and temperature voltage into the digital domain.

2.5.4 Digital Signal Processing Unit

The Digital Signal Processing Unit (DSPU) contains the:

- **C**apture **C**ompare **U**nit (**CCU**), which is used to generate the PWM signal
- **C**Oordinate **R**otation **D**igital **C**omputer (**CORDIC**), which contains the trigonometric function for angle calculation
- Fuses, which contain the calibration parameters

2.5.5 Interfaces

Different Interfaces can be selected:

- SSC Interface
- PWM
- Incremental Interface
- Hall Switch Mode

2.5.6 Safety Features

The TLE5012 offers a multiplicity of safety features to support Safety Integrity Level (SIL). Sensors with this performance are identified by the following logo:



Figure 5 PRO-SIL™ Logo

Safety features are:

- Test vectors switchable to ADC input
- Inversion or combination of filter input streams
- Data transmission check via 8-bit Cyclic Redundancy Check (CRC)
- Self-test routines
- Two independent active interfaces possible
- Overvoltage and undervoltage detection

Disclaimer

PRO-SIL™ is a Registered Trademark of Infineon Technologies AG.

The PRO-SIL™ Trademark designates Infineon products which contain SIL Supporting Features.

SIL Supporting Features are intended to support the overall System Design to reach the desired SIL (according to IEC61508) or A-SIL (according to ISO26262) level for the high efficiency Safety System.

SIL respectively A-SIL certification for such a system has to be reached on system level by the System Responsible at an accredited Certification Authority.

SIL stands for Safety Integrity Level (according to IEC 61508)

A-SIL stands for Automotive-Safety Integrity Level (according to ISO 26262)

3 Specifications

3.1 Application Circuit

The application circuits shown in [Figure 6](#), [Figure 7](#), [Figure 8](#) and [Figure 9](#) show the various communication possibilities of the TLE5012.

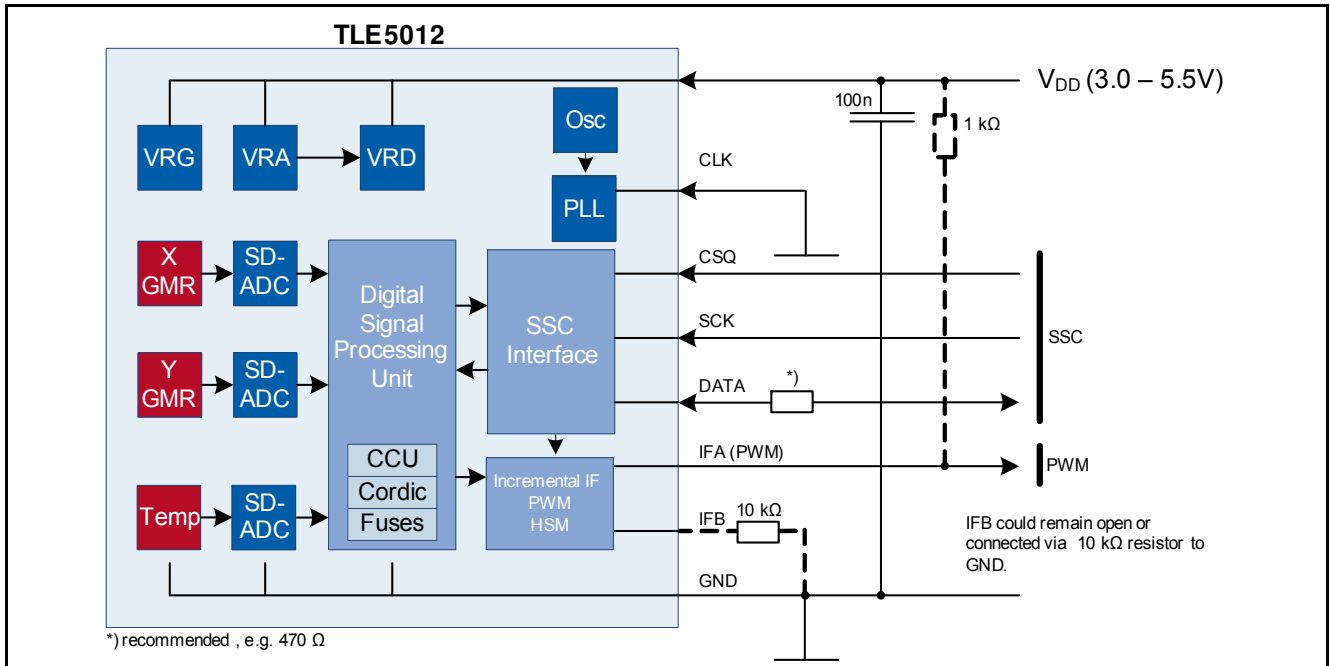

Figure 6 Application circuit for TLE5012 with SSC and PWM Interface (using internal CLK)

[Figure 6](#) shows a basic block diagram of the TLE5012 with PWM Interface. This interface is selectable by connecting CLK to GND. In addition to the PWM, the SSC Interface could be used. Within the SSC Interface, the PWM Mode is selectable between push-pull and open drain.

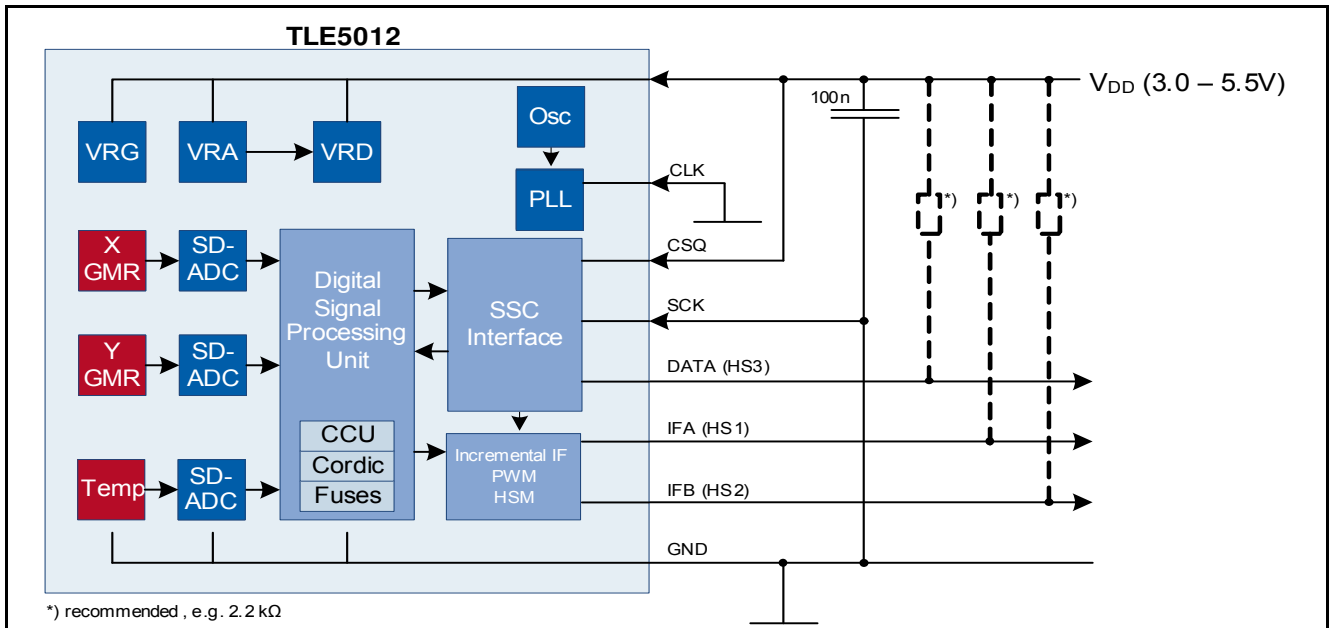

Figure 7 Application circuit for TLE5012 with HS Mode (using internal CLK)

Figure 7 shows a basic block-diagram of the TLE5012 in the Hall Switch Mode. This interface is selectable by connecting CLK to GND and CSQ to V_{DD} . In addition to the HSM, the SSC Interface can be used by pulling CSQ to GND. Within the SSC Interface, the HSM is selectable between push-pull and open drain.

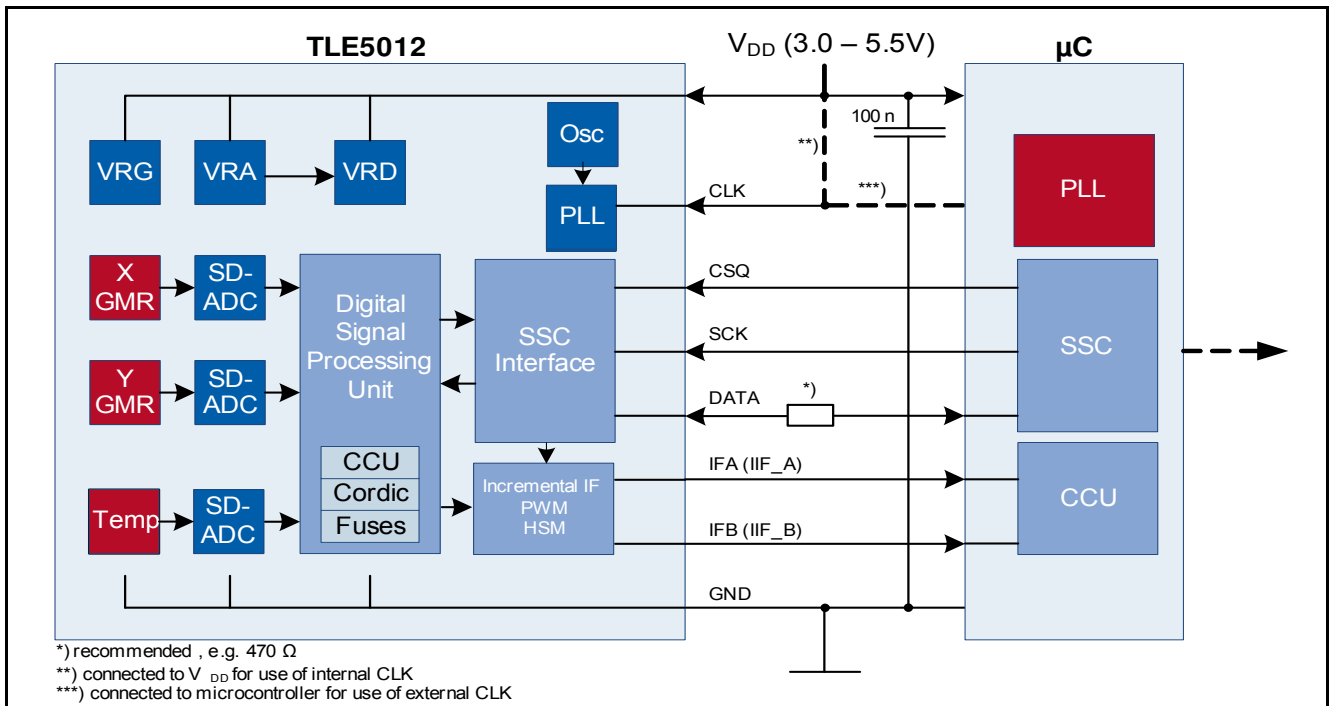

Figure 8 Application circuit for TLE5012 with SSC Interface and IIF (using external CLK)

Figure 8 shows a basic block diagram of an angle sensor system using a TLE5012 and a microcontroller for rotor-positioning applications. The interface configuration depicted is needed for high-speed applications such as electrical commutated motor drives. It is possible to connect the TLE5012 to a microcontroller via the Incremental Interface, and for safety reasons also via the SSC Interface.

The TLE5012 Exxxx can be configured with PWM only (Figure 9). This is not possible with the Standard TLE5012 type.¹⁾

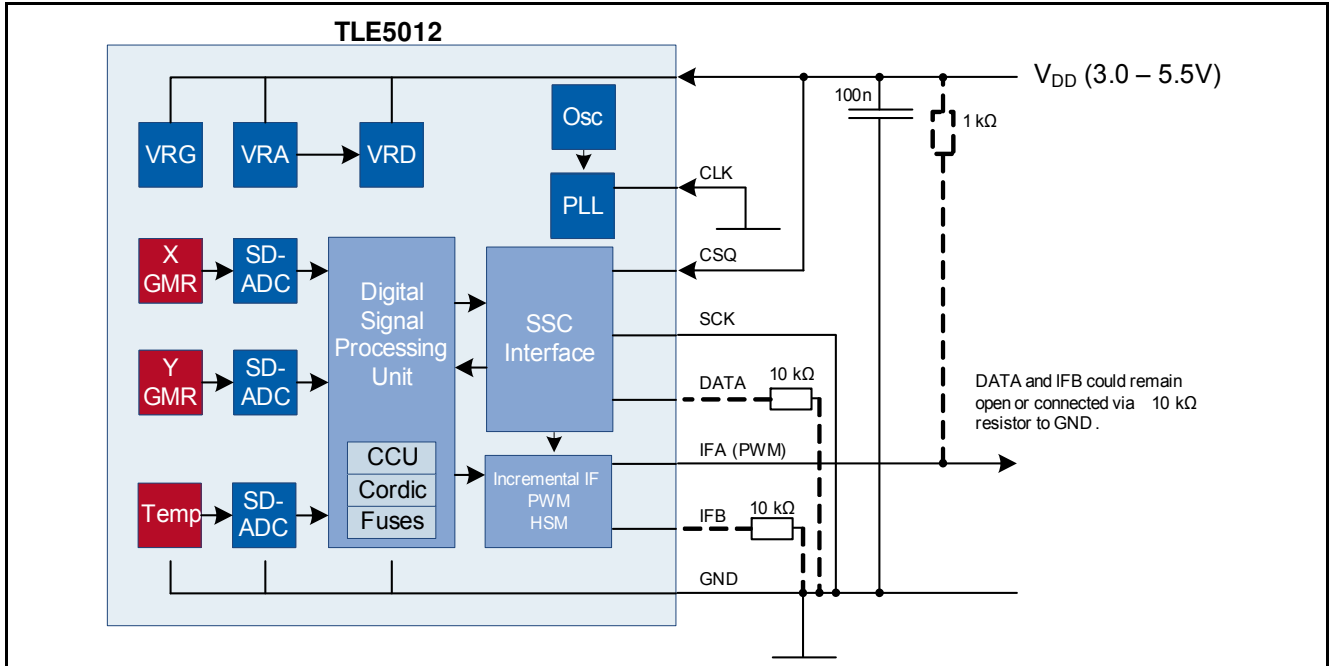

Figure 9 Application circuit for TLE5012 with only PWM Interface (using internal CLK)

1) For more information, please contact Infineon

3.2 Absolute Maximum Ratings

Table 2 Absolute maximum ratings

Parameter	Symbol	Values			Unit	Note / Test Condition
		Min.	Typ.	Max.		
Voltage on V_{DD} pin with respect to ground (V_{SS})	V_{DD}	-0.5	-	6.5	V	Max. 40 h/lifetime
Voltage on any pin with respect to ground (V_{SS})	V_{IN}	-0.5	-	6.5	V	Additionally $V_{DD} + 0.5$ V may not be exceeded
Junction temperature	T_J	-40	-	150	°C	
		-	-	150	°C	For 1000 h not additive
Magnetic field induction	B	-	-	125	mT	Max. 5 min @ $T_A = 25^\circ\text{C}$
		-	-	100	mT	Max. 5 h @ $T_A = 25^\circ\text{C}$
Storage temperature	T_{ST}	-40	-	150	°C	Without magnetic field

Attention: Stresses above the max. values listed here may cause permanent damage to the device. Exposure to absolute maximum rating conditions for extended periods may affect device reliability. Maximum ratings are absolute ratings; exceeding only one of these values may cause irreversible damage to the device.

3.3 Operating Range

The following operating conditions must not be exceeded in order to ensure correct operation of the TLE5012. All parameters specified in the following sections refer to these operating conditions, unless otherwise noted. **Table 3** is valid for $-40^\circ\text{C} < T_J < 150^\circ\text{C}$ unless otherwise noted.

Table 3 Operating range

Parameter	Symbol	Values			Unit	Note / Test Condition
		Min.	Typ.	Max.		
Supply voltage	V_{DD}	3.0	5.0	5.5	V	¹⁾
Output current (DATA-Pad)	I_Q	-	-	-25	mA	PAD_DRV = '0x', sink current ²⁾³⁾
		-	-	-5	mA	PAD_DRV = '10', sink current ²⁾³⁾
		-	-	-0.4	mA	PAD_DRV = '11', sink current ²⁾³⁾
Output current (IFA / IFB-Pad)	I_Q	-	-	-15	mA	PAD_DRV = '0x', sink current ²⁾³⁾
		-	-	-5	mA	PAD_DRV = '1x', sink current ²⁾³⁾
Input voltage	V_{IN}	-0.3	-	5.5	V	$V_{DD} + 0.3$ V may not be exceeded

Table 3 Operating range (cont'd)

Parameter	Symbol	Values			Unit	Note / Test Condition
		Min.	Typ.	Max.		
Magnetic induction at $T_A = 25^\circ\text{C}$ 4)5)	B_{XY}	30	-	50	mT	$-40^\circ\text{C} < T_J < 150^\circ\text{C}$
	B_{XY}	30	-	60	mT	$-40^\circ\text{C} < T_J < 100^\circ\text{C}$
	B_{XY}	30	-	70	mT	$-40^\circ\text{C} < T_J < 85^\circ\text{C}$
Expanded magnetic induction at $T_A = 25^\circ\text{C}$ 4)5)	B_{XY}	25	-	30	mT	Additional angle error of 0.1° 6)
Angle range	Ang	0	-	360	°	

- 1) Directly blocked with 100-nF ceramic capacitor
- 2) Max. current to GND over open-drain output
- 3) At $V_{DD} = 5\text{V}$
- 4) Values refer to an homogenous magnetic field (B_{XY}) without vertical magnetic induction ($B_Z = 0\text{mT}$)
- 5) See [Figure 10](#)
- 6) 0 h

The field strength of a magnet can be selected within the colored area in [Figure 10](#). By limitation of the junction temperature, a higher magnetic field can be applied. In case of a maximum temperature $T_J=100^\circ\text{C}$ a magnet with up to 60mT at $T_A=25^\circ\text{C}$ is allowed.

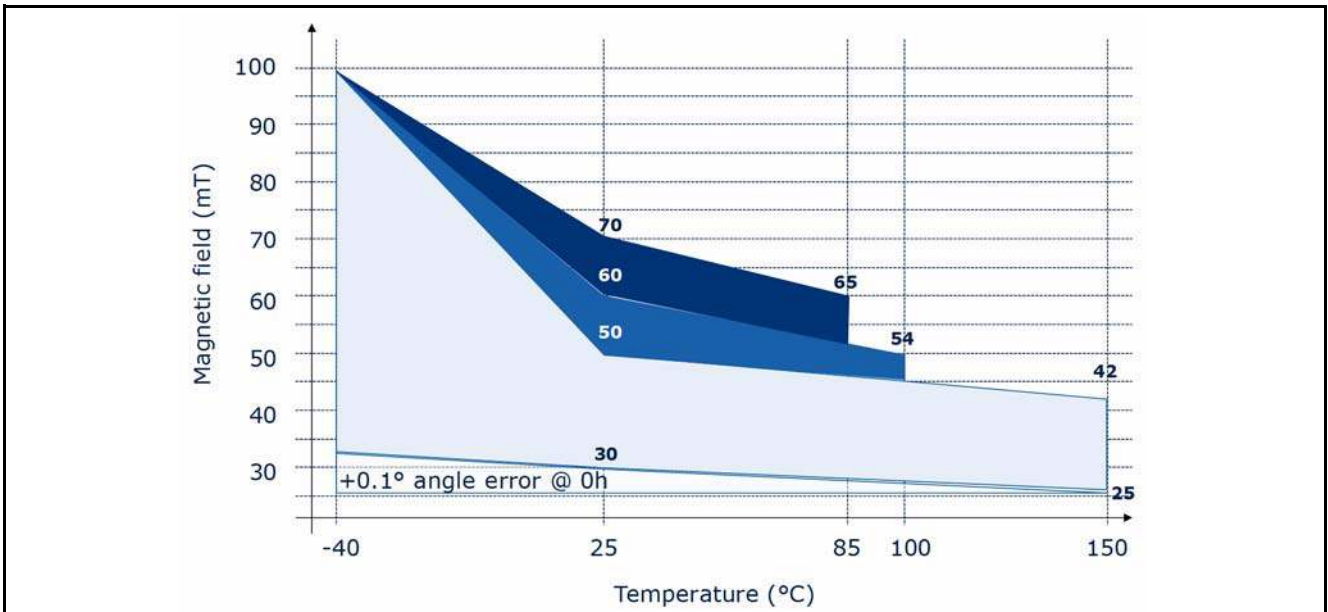

Figure 10 Magnet performance (ambient temperature)

Note: The thermal resistances listed in [Table 29 "Package parameters" on Page 61](#) must be used to calculate the corresponding ambient temperature.

Calculation of the Junction Temperature

The total power dissipation P_{TOT} of the chip increases its temperature above the ambient temperature.

The power multiplied by the total thermal resistance R_{thJA} (Junction to Ambient) leads to the final junction temperature. R_{thJA} is the sum of the addition of the values of the two components Junction to Case and Case to Ambient.

$$R_{thJA} = R_{thJC} + R_{thCA} \tag{1}$$

$$T_J = T_A + \Delta T$$

$$\Delta T = R_{thJA} \times P_{TOT} = R_{thJA} \times (V_{DD} \times I_{DD} + V_{OUT} \times I_{OUT}) \quad (I_{DD}, I_{OUT} > 0, \text{ if direction is into IC})$$

Example (assuming no load on V_{out}):

$$V_{DD} = 5V \tag{2}$$

$$I_{DD} = 14mA$$

$$\Delta T = 150 \left[\frac{K}{W} \right] \times (5[V] \times 0.014[A] + 0[VA]) = 10.5 K$$

For molded sensors, the calculation with R_{thJC} is more appropriate.

3.4 Characteristics

3.4.1 Electrical Parameters

The indicated electrical parameters apply to the full operating range, unless otherwise specified. The typical values correspond to a supply voltage $V_{DD} = 5.0 V$ and $25^\circ C$, unless individually specified. All other values correspond to $-40^\circ C < T_J < 150^\circ C$.

Table 4 Electrical parameters

Parameter	Symbol	Values			Unit	Note / Test Condition
		Min.	Typ.	Max.		
Supply current	I_{DD}	-	14	16	mA	
POR level	V_{POR}	2.0	-	2.9	V	Power-On Reset
POR hysteresis ¹⁾	V_{PORhy}	-	30	-	mV	
Pull-Up current	I_{PU}	-10	-	-225	μA	CSQ
		-10	-	-150	μA	DATA
Pull-Down current	I_{PD}	10	-	225	μA	SCK
		10	-	150	μA	CLK, IFA, IFB
Power-on time	t_{Pon}	-	5	7	ms	$V_{DD} > V_{DDmin}$ ²⁾

1) Not subject to production test - verified by design/characterization

2) Within "Power-On Time," write access is not permitted

Table 5 Electrical parameters for $4.5V < V_{DD} < 5.5V$

Parameter	Symbol	Values			Unit	Note / Test Condition
		Min.	Typ.	Max.		
Input signal low level	V_{L5}	-	-	$0.3 V_{DD}$	V	
Input signal high level	V_{H5}	$0.7 V_{DD}$	-	-	V	
Output signal low level	V_{OL5}	-	-	1	V	DATA; $I_Q = - 25 \text{ mA}$ (PAD_DRV='0x'), $I_Q = - 5 \text{ mA}$ (PAD_DRV='10'), $I_Q = - 0.4 \text{ mA}$ (PAD_DRV='11')
		-	-	1	V	IFA,IFB; $I_Q = - 15 \text{ mA}$ (PAD_DRV='0x'), $I_Q = - 5 \text{ mA}$ (PAD_DRV='1x')

Table 6 Electrical parameters for $3.0V < V_{DD} < 3.6V$

Parameter	Symbol	Values			Unit	Note / Test Condition
		Min.	Typ.	Max.		
Input signal low level	V_{L3}	-	-	$0.2 V_{DD}$	V	
Input signal high level	V_{H3}	$0.8 V_{DD}$	-	-	V	
Output signal low level	V_{OL3}	-	-	0.9	V	DATA; $I_Q = - 15 \text{ mA}$ (PAD_DRV='0x'), $I_Q = - 3 \text{ mA}$ (PAD_DRV='10'), $I_Q = - 0.24 \text{ mA}$ (PAD_DRV='11')
		-	-	0.9	V	IFA,IFB; $I_Q = - 10 \text{ mA}$ (PAD_DRV='0x'), $I_Q = - 3 \text{ mA}$ (PAD_DRV='1x')

3.4.2 ESD Protection

Table 7 ESD protection

Parameter	Symbol	Values		Unit	Notes
		min.	max.		
ESD voltage	V_{HBM}	-	± 4.0	kV	Human Body Model ¹⁾
	V_{SDM}	-	± 0.5	kV	Socketed Device Model ²⁾

1) Human Body Model (HBM) according to AEC-Q100-002

2) Socketed Device Model (SDM) according to ESDA/ANSI/ESD SP5.3.2-2008

3.4.3 GMR Parameters

All parameters apply over $B_{XY} = 30\text{mT}$ and $T_A = 25^\circ\text{C}$, unless otherwise specified.

Table 8 Basic GMR parameters

Parameter	Symbol	Values			Unit	Note / Test Condition
		Min.	Typ.	Max.		
X, Y output range	RG_{ADC}	-	-	± 23230	digits	4)
X, Y amplitude ¹⁾	A_X, A_Y	6000	9500	15781	digits	
		3922	-	20620	digits	operating range
X, Y synchronism ²⁾	k	87.5	100	112.49	%	
X, Y offset ³⁾	O_X, O_Y	-2048	0	+2047	digits	
X, Y orthogonality error	Φ	-11.25	0	+11.24	°	
X, Y without field	X_0, Y_0	-5000	-	+5000	digits	without magnet ⁴⁾

- 1) See [Figure 11](#)
- 2) $k = 100 \cdot (A_X / A_Y)$
- 3) $O_Y = (Y_{MAX} + Y_{MIN}) / 2$; $O_X = (X_{MAX} + X_{MIN}) / 2$
- 4) Not subject to production test - verified by design/characterization

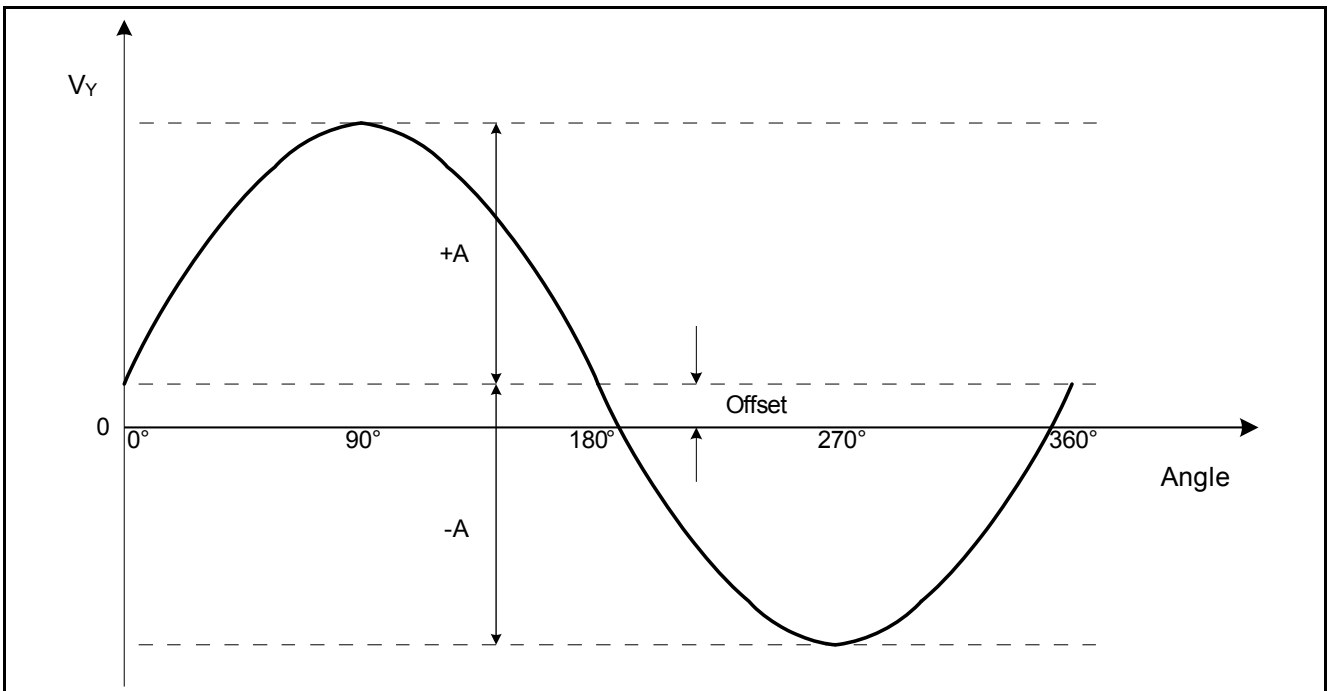

Figure 11 Offset and amplitude definition

3.4.4 Angle Performance

After internal calculation the sensor has a remaining error, as shown in [Table 11](#). The error value refers to $B_z = 0\text{mT}$ and the operating conditions given in [Table 3 “Operating range” on Page 18](#).

The overall angle error represents the relative angle error. This error describes the deviation from the reference line after zero angle definition.

Table 9 Angle performance

Parameter	Symbol	Values			Unit	Note / Test Condition
		Min.	Typ.	Max.		
Overall Angle Error (with auto-calibration)	α_{Err}	-	0.6 ¹⁾	1.0	°	including lifetime and temperature drift ²⁾³⁾⁴⁾
Overall Angle Error (without auto-calibration)	α_{Err}	-	0.6 ¹⁾	1.6	°	including temperature drift ²⁾³⁾⁵⁾

1) At 25°C, B = 30 mT

2) Including hysteresis error, caused by revolution direction change.

3) Only with calibrated GMR-compensation parameters of customer setup; Relative error after zero angle definition.

4) Not subject to production test - verified by design/characterization

5) 0 h

Autocalibration

The autocalibration enables online parameter calculation and therefore reduces the angle error due to temperature drift, lifetime drift, and misalignments.

The TLE5012 is a pre-calibrated sensor. After start-up, the parameters out of the laser fuses get loaded into flip-flops. The TLE5012 needs more than a full revolution to generate new parameters. The update mode can be chosen within the Interface Mode 2 register (AUTOCAL). The parameters are updated in a smooth way to avoid an angle jump on the output. Therefore only one LSB will be changed within the chosen range or time. The autocalibration is done continuously.

AUTOCAL Modes:

- 00: No autocalibration
- 01: Autocalibration Mode 1. Only one LSB to final values within the update time t_{upd} (depending on FIR_MD setting).
- 10: Autocalibration Mode 2. Only one LSB update over one full revolution. After update of one LSB, the autocalibration will calculate the parameters again.
- 11: Autocalibration Mode 3. Only one LSB to final values within an angle range of 11.25°.

3.4.5 Signal Processing

The signal path of the TLE5012 is depicted in [Figure 12](#). It consists of the GMR bridge, ADC, filter, and angle calculation. Depending on the filter configuration, various total delay times are achieved. In addition to this delay time, the delay time of the interface has to be considered. The delay time leads to an additional angle error at higher speeds. By enabling the prediction, the signal delay time can be reduced ([Figure 13](#)). The prediction uses the difference between current and last angle value and calculates the output value by adding this difference to the current value. A linear prediction is thereby achieved.

$$\alpha(t+1) = 2 \cdot \alpha(t) - \alpha(t-1) \tag{3}$$

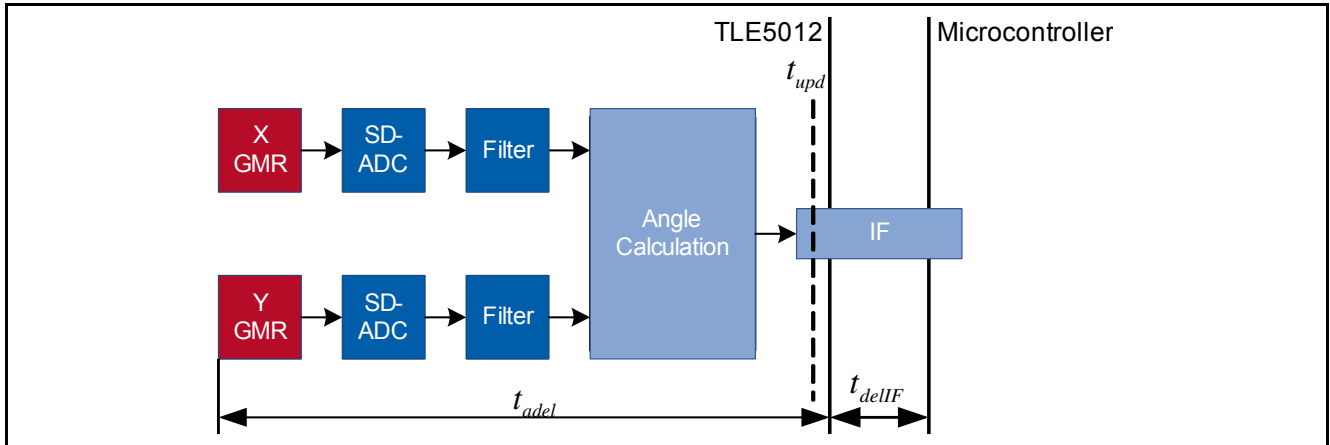

Figure 12 TLE5012 signal path

At FIR_MD = 0 only raw values can be read out, due to the more time consuming angle calculation.

Table 10 Signal processing

Parameter	Symbol	Values			Unit	Note / Test Condition
		Min.	Typ.	Max.		
Update rate at interface	t_{upd}	-	21.3	-	μs	FIR_MD = 0 (only raw values) ¹⁾²⁾
		-	42.7	-	μs	FIR_MD = 1 ¹⁾²⁾
		-	85.3	-	μs	FIR_MD = 2 (default) ¹⁾²⁾
		-	170.6	-	μs	FIR_MD = 3 ¹⁾²⁾
Angle delay time ³⁾	t_{adel}	-	60	70	μs	FIR_MD = 1 ¹⁾²⁾
		-	80	95	μs	FIR_MD = 2 ¹⁾²⁾
		-	120	140	μs	FIR_MD = 3 ¹⁾²⁾
Angle delay time with prediction ³⁾	t_{adel}	-	20	30	μs	FIR_MD = 1; PREDICT = 1 ¹⁾²⁾
		-	5	20	μs	FIR_MD = 2; PREDICT = 1 ¹⁾²⁾
		-	-40	-20	μs	FIR_MD = 3; PREDICT = 1 ¹⁾²⁾
Angle noise	N_{Angle}	-	0.11	-	$^{\circ}$	FIR_MD = 0, (1 sigma) ²⁾
		-	0.08	-	$^{\circ}$	FIR_MD = 1, (1 sigma) ²⁾
		-	0.05	-	$^{\circ}$	FIR_MD = 2, (1 sigma) ²⁾ (default)
		-	0.04	-	$^{\circ}$	FIR_MD = 3, (1 sigma) ²⁾

1) Depends on internal oscillator frequency variation ([Section 3.4.6](#))

2) Not subject to production test - verified by design/characterization

3) Valid at constant rotation speed

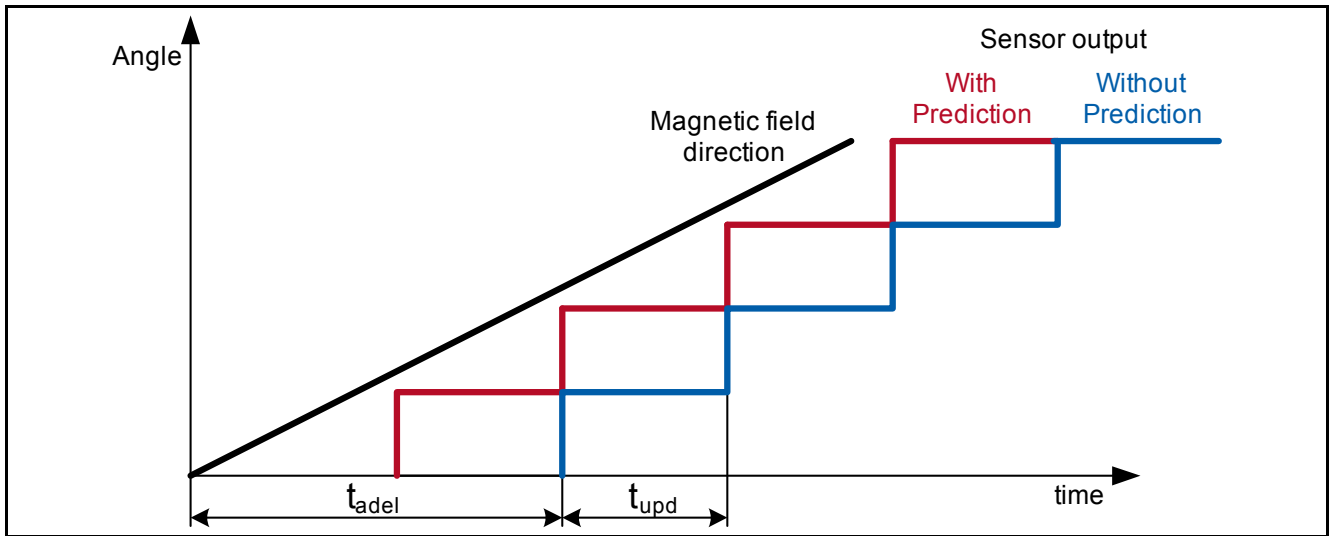

Figure 13 Delay of sensor output

3.4.6 Clock Supply (CLK Timing Definition)

If the external clock supply is selected, the clock signal input CLK must fulfill certain requirements:

- The high or low pulse width must not exceed the specified values, because the PLL needs a minimum pulse width and must be spike filtered.
- The duty cycle factor should be 0.5 but can deviate to the values limited by $t_{CLKh(f_{min})}$ and $t_{CLKl(f_{min})}$.
- The PLL is triggered at the positive edge of the clock; if more than 2 edges are missing, a chip reset is generated automatically.

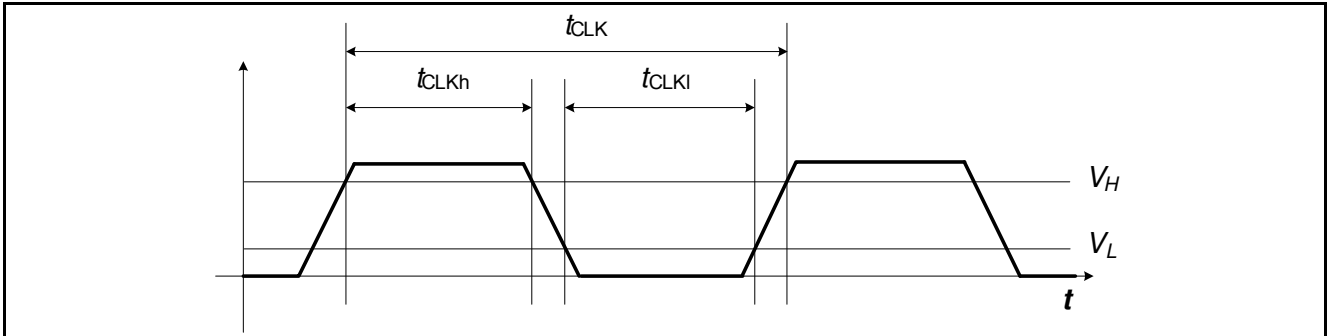

Figure 14 External CLK timing definition

Table 11 CLK timing specification

Parameter	Symbol	Values			Unit	Note / Test Condition
		Min.	Typ.	Max.		
Input frequency	f_{CLK}	3.8	4.0	4.2	MHz	
CLK duty cycle ¹⁾²⁾	CLK_{DUTY}	30	50	70	%	
CLK rise time	t_{CLKr}	-	-	30	ns	From V_L to V_H ³⁾
CLK fall time	t_{CLKf}	-	-	30	ns	From V_H to V_L ³⁾
Digital clock	f_{DIG}	22.8	24	25.2	MHz	
Internal oscillator frequency	f_{CLK}	3.8	4.0	4.2	MHz	

1) Minimum Duty Cycle Factor: $t_{CLKh(f_{min})} / t_{CLK(f_{min})}$ with $t_{CLK(f_{min})} = 1 / f_{CLK(f_{min})}$

2) Maximum Duty Cycle Factor: $t_{CLKh(f_{max})} / t_{CLK(f_{min})}$ with $t_{CLKh(f_{max})} = t_{CLK(f_{min})} - t_{CLKl(min)}$

3) Not subject to production test - verified by design/characterization

3.5 Interfaces

Within the register MOD_3, the driver strength and so the slope for push-pull communication can be varied with the sensor output. The driver strength is specified in [Table 3](#) and the slope fall and rise times in [Table 12](#).

Table 12 PAD characteristics

Parameter	Symbol	Values			Unit	Note / Test Condition
		Min.	Typ.	Max.		
Output fall time	t_{fall}, t_{rise}	-	-	8	ns	DATA, 50 pF, PAD_DRV='00' ¹⁾²⁾
Output rise time		-	-	28	ns	DATA, 50 pF, PAD_DRV='01' ¹⁾²⁾
		-	-	45	ns	DATA, 50 pF, PAD_DRV='10' ¹⁾²⁾
		-	-	130	ns	DATA, 50pF, PAD_DRV='11' ¹⁾²⁾
		-	-	15	ns	IFA/IFB, 20 pF, PAD_DRV='0x' ¹⁾²⁾
		-	-	30	ns	IFA/IFB, 20 pF, PAD_DRV='1x' ¹⁾²⁾

- 1) Valid for push-pull output
- 2) Not subject to production test - verified by design/characterization

3.5.1 Synchronous Serial Communication (SSC) Interface

The 3-pin SSC Interface has a bi-directional push-pull data line, serial clock signal, and chip select. The SSC Interface is designed to communicate with a microcontroller peer-to-peer for fast applications.

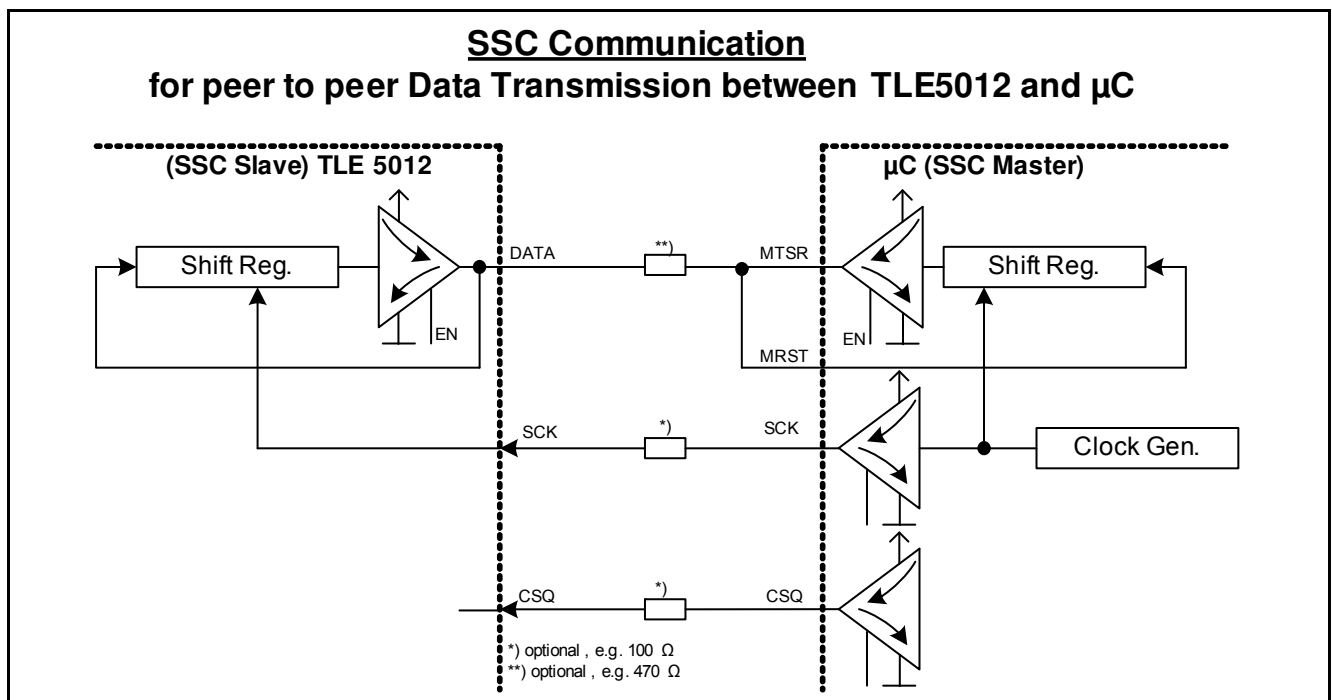

Figure 15 SSC configuration in sensor-slave mode with push-pull outputs (high speed application)

Another possibility is a 3-pin SSC Interface with bidirectional open-drain data line, serial clock signal, and chip select. This setup is designed to communicate with a microcontroller in a bus system, together with other SSC slaves (e.g. two TLE5012 devices for redundancy reasons). This mode can be activated using bit SSC_OD.

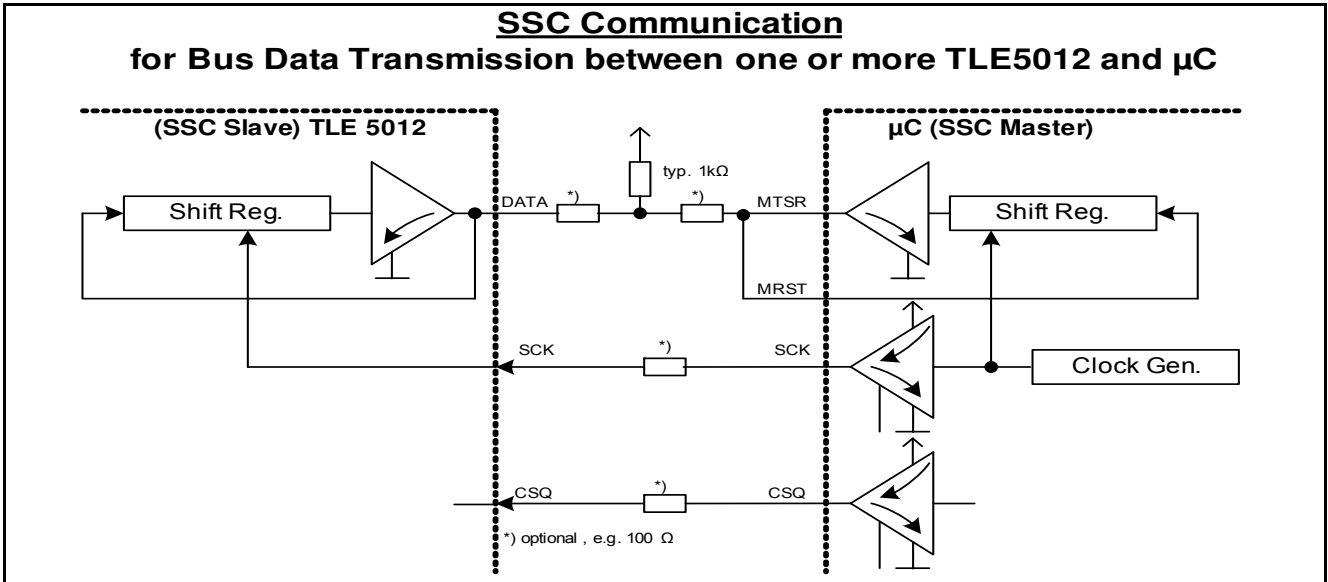

Figure 16 SSC configuration in sensor-slave mode and open drain (safe bus systems)

3.5.1.1 SSC Timing Definition

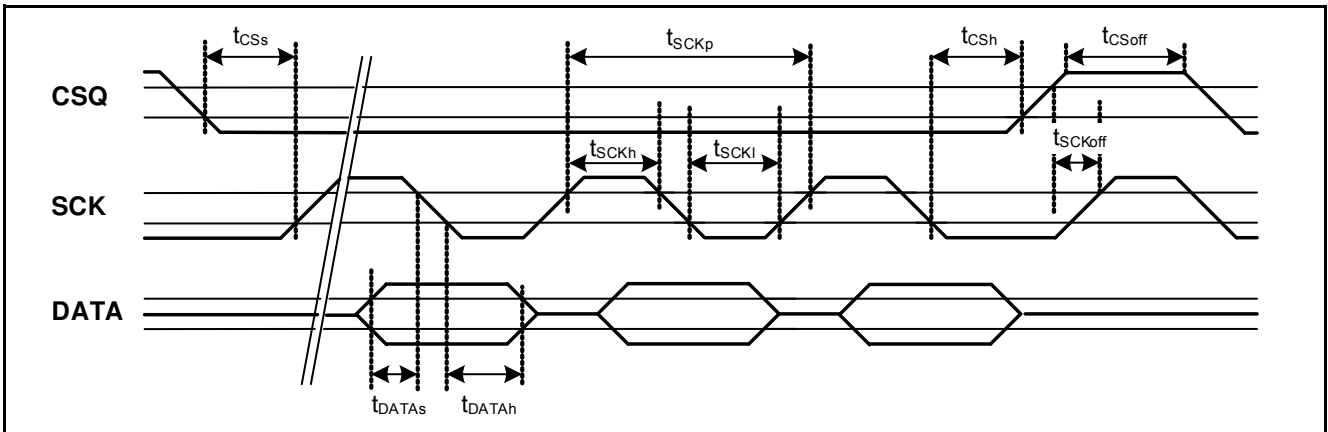

Figure 17 SSC timing

SSC Inactive Time (CS_{off})

The SSC inactive time defines the delay time after a transfer before the TLE5012 can be selected again.

Table 13 SSC push-pull timing specification

Parameter	Symbol	Values			Unit	Note / Test Condition
		Min.	Typ.	Max.		
SSC baud rate	f _{SSC}	-	8.0	-	Mbit/s	1)
CSQ setup time	t _{CSs}	105	-	-	ns	1)

Table 13 SSC push-pull timing specification (cont'd)

Parameter	Symbol	Values			Unit	Note / Test Condition
		Min.	Typ.	Max.		
CSQ hold time	t_{CSH}	105	-	-	ns	1)
CSQ off	t_{CSoff}	600	-	-	ns	SSC inactive time ¹⁾
SCK period	t_{SCKp}	120	125	-	ns	1)
SCK high	t_{SCKh}	40	-	-	ns	1)
SCK low	t_{SCKl}	30	-	-	ns	1)
DATA setup time	t_{DATA_s}	25	-	-	ns	1)
DATA hold time	t_{DATA_h}	40	-	-	ns	1)
Write read delay	t_{wr_delay}	130	-	-	ns	1)
SCK off	t_{SCKoff}	170	-	-	ns	1)

1) Not subject to production test - verified by design/characterization

Table 14 SSC open-drain timing specification

Parameter	Symbol	Values			Unit	Note / Test Condition
		Min.	Typ.	Max.		
SSC baud rate	f_{SSC}	-	2.0	-	Mbit/s	Pull-up Resistor = 1k Ω ¹⁾
CSQ setup time	t_{CS_s}	300	-	-	ns	1)
CSQ hold time	t_{CSH}	400	-	-	ns	1)
CSQ off	t_{CSoff}	600	-	-	ns	SSC inactive time ¹⁾
SCK period	t_{SCKp}	500	-	-	ns	1)
SCK high	t_{SCKh}	-	190	-	ns	1)
SCK low	t_{SCKl}	-	190	-	ns	1)
DATA setup time	t_{DATA_s}	25	-	-	ns	1)
DATA hold time	t_{DATA_h}	40	-	-	ns	1)
Write read delay	t_{wr_delay}	130	-	-	ns	1)
SCK off	t_{SCKoff}	170	-	-	ns	1)

1) Not subject to production test - verified by design/characterization

3.5.1.2 SSC Data Transfer

The SSC data transfer is word-aligned. The following transfer words are possible:

- Command Word (to access and change operating modes of the TLE5012)
- Data Words (any data transferred in any direction)
- Safety Word (confirms the data transfer and provide status information)

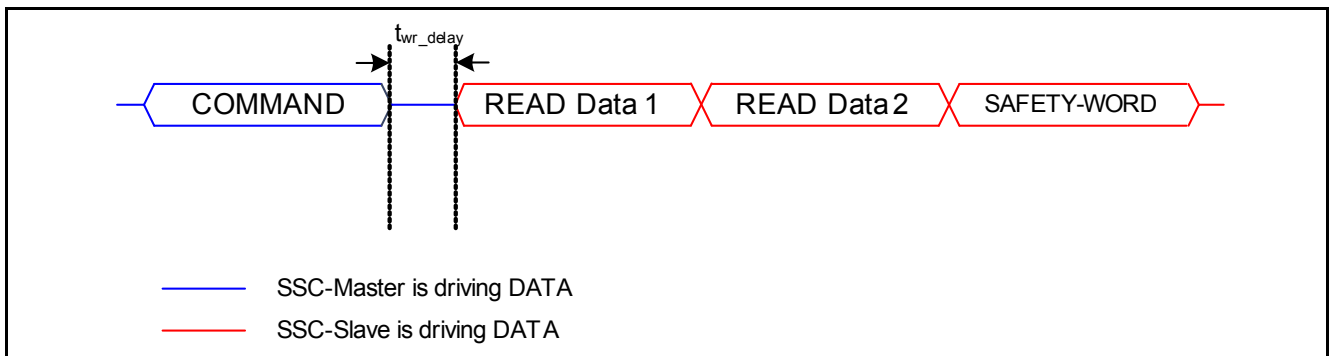

Figure 18 SSC data transfer (data-read example)

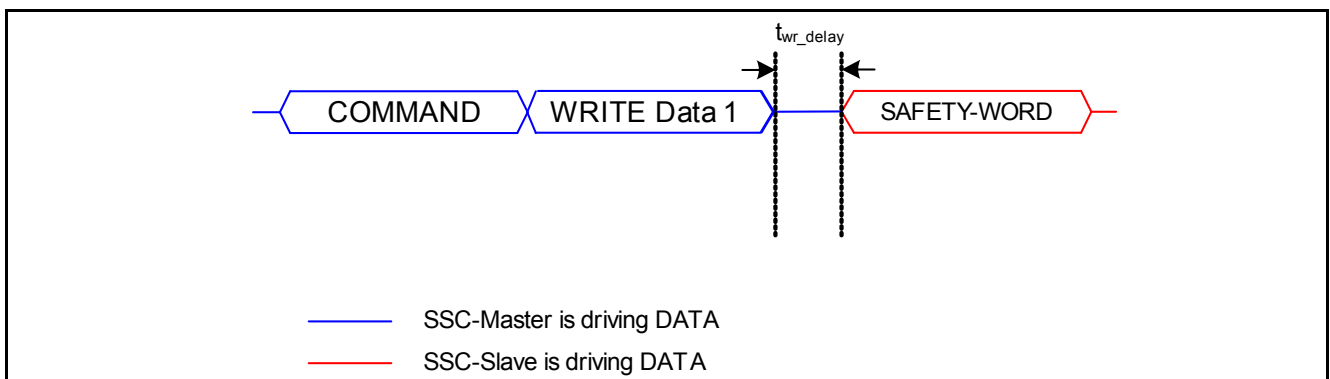

Figure 19 SSC data transfer (data-write example)

Command Word

The TLE5012 is controlled by a Command Word. It is sent first at the start of every data transmission. The structure of the Command Word is shown in [Table 15](#), where the update (UPD) bit allows access to current or updated values. If an update command is issued and UPD is set, the immediate values are stored in the update buffer simultaneously. This enables a snapshot of all necessary system parameters at the same time. Bits with an update buffer are marked by an “u” in the bit type in the register description.

Table 15 Structure of the Command Word

Name	Bits	Description
RW	[15]	Read - write 0:Write 1:Read
Lock	[14..11]	4-bit lock value 0000 _B : Default operating access for addresses 0x00:0x04 1010 _B : Config- access for addresses 0x05:0x11
UPD	[10]	Update register access 0: Access to current values 1: Access to updated values

Table 15 Structure of the Command Word

Name	Bits	Description
ADDR	[9..4]	6-bit Address
ND	[3..0]	4-bit Number of data words

Safety Word

The Safety Word contains following bits:

Table 16 Structure of the Safety Word

Name	Bits	Description
STAT	Chip and Interface Status	
	[15]	Indication of chip reset (resets after readout) via SSC 0: Reset occurred 1: No reset Reset: 1 _B
	[14]	System error (e.g. overvoltage; undervoltage; V _{DD-} , GND- off; ROM;...) 0: Error occurred (S_VR; S_DSPU; S_OV; S_XYOL: S_MAGOL; S_ADCM; S_FUSE) 1: No error
	[13]	Interface access error (access to wrong address; wrong lock) 0: Error occurred 1: No error
	[12]	Valid angle value (no system error; no interface error; NO_GMR_A = '0'; NO_GMR_XY='0') 0: Angle value invalid 1: Angle value valid
RESP	[11..8]	Sensor number response indicator The sensor no. bit is pulled low and the other bits are high
CRC	[7..0]	Cyclic Redundancy Check

Bit Types

The types of bits used in the registers are listed here:

Table 17 Bit types

Abbreviation	Function	Description
R	Read	Read-only registers
W	Write	Read and write registers
U	Update	Update buffer for this bit is present. If an update is issued and the Update Register Access bit (UPD in Command Word) is set, the immediate values are stored in this update buffer simultaneously. This enables a snapshot of all necessary system parameters at the same time.

Data Communication via SSC

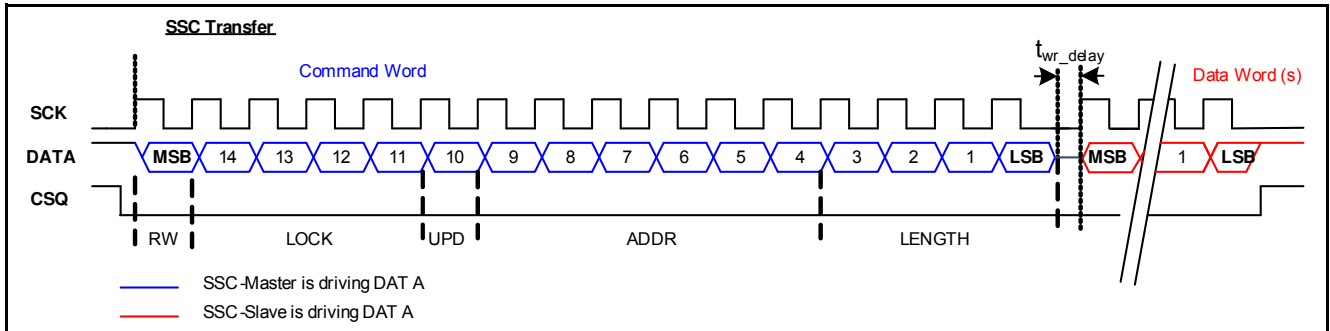

Figure 20 SSC bit ordering (read example)

The data communication via SSC Interface has the following characteristics:

- The data transmission order is “Most Significant Bit (MSB) first”.
- Data is put on the data line with the rising edge on SCK and read with the falling edge on SCK.
- The SSC Interface is word-aligned. All functions are activated after each transmitted word.
- A “high” condition on the negated Chip Select pin (CSQ) of the selected TLE5012 interrupts the transfer immediately. The CRC calculator is automatically reset.
- After changing the data direction, a delay (t_{wr_delay}) has to occur before continuing the data transfer. This is necessary for internal register access.
- Every access to the TLE5012 with the number of data (ND) ≥ 1 is performed with address auto-increment. At an overflow at address $3F_H$ the transfer continuous at address 00_H .
- With ND = 0, no auto-increment is done and a continuously readout of the same address can occur. Afterwards no Safety Word is sent and the transfer ends with high condition on CSQ.
- After every data transfer with ND ≥ 1 , the 16-bit Safety Word will be appended by the selected TLE5012.
- After the Safety Word is sent, the transfer ends. To start another data transfer, the CSQ has to be deselected once for t_{CSoff} .
- The SSC is by default push-pull. The push-pull driver is active only if the TLE5012 has to send data; otherwise the push-pull is disabled for receiving data from the microcontroller.

Cyclic Redundancy Check (CRC)

- This CRC complies with the J1850 Bus Specification.
- Every new transfer resets the CRC generation.
- Every byte of a transfer will be taken into account to generate the CRC (also the sent command(s)).
- Generator polynomial: $X^8+X^4+X^3+X^2+1$, but for the CRC generation the fast CRC generation circuit is used (see Figure 21)
- The remainder of the fast CRC circuit is initial set to '11111111_B'.
- The remainder is inverted before transmission.

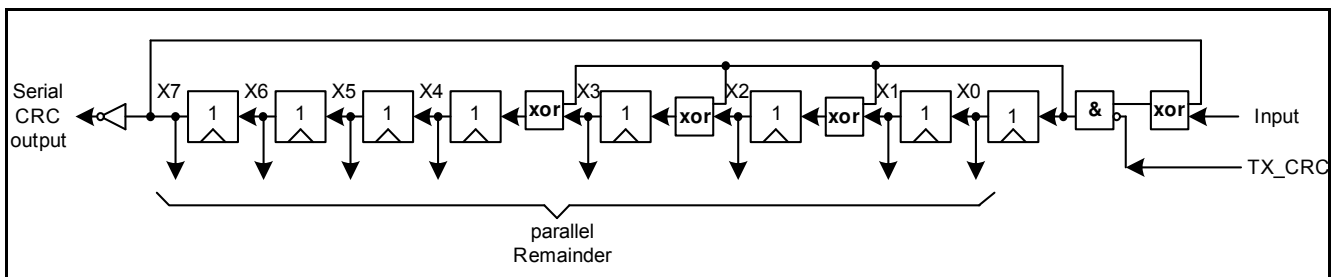

Figure 21 Fast CRC polynomial division circuit

3.5.1.3 Registers

This section describes the registers of the TLE5012. It also specifies the read/write access rights of the specific registers. **Table 18** identifies the values with symbols. Access to the registers is accomplished via the SSC Interface.

Table 18 Registers Overview

Register Short Name	Register Long Name	Offset Address	Page Number
Registers, TLE5012 Register			
STAT	Status Register	00 _H	34
ACSTAT	Activation Status Register	01 _H	36
AVAL	Angle Value Register	02 _H	37
ASPD	Angle Speed Register	03 _H	38
AREV	Angle Revolution Register	04 _H	39
FSYNC	Frame Synchronization Register	05 _H	39
MOD_1	Interface Mode1 Register	06 _H	40
SIL	SIL Register	07 _H	41
MOD_2	Interface Mode2 Register	08 _H	42
MOD_3	Interface Mode3 Register	09 _H	43
OFFX	Offset X	0A _H	44
OFFY	Offset Y	0B _H	45
SYNCH	Synchronicity	0C _H	45
IFAB	IFAB Register	0D _H	46
MOD_4	Interface Mode4 Register	0E _H	47
TCO_Y	Temperature Coefficient Register	0F _H	48
ADC_X	X-raw value	10 _H	48
ADC_Y	Y-raw value	11 _H	49
IIF_CNT	IIF Counter value	20 _H	49

The register is addressed wordwise.

3.5.1.3.1 TLE5012 Register

Status Register

STAT Offset Reset Value
 Status Register 00_H 8001_H

15	14	13	12	11	10	9	8
RD_ST	S_NR		NO_GMR_A	NO_GMR_XY	S_ROM	S_ADCT	Res
r	w		ru	ru	r	ru	
7	6	5	4	3	2	1	0
S_MAGOL	S_XYOL	S_OV	S_DSPU	S_FUSE	S_VR	S_WD	S_RST
ru	ru	ru	ru	ru	ru	ru	ru

Field	Bits	Type	Description
RD_ST	15	r	Read Status 0 _B status values not changed since last readout 1 _B status values changed Reset: 1 _B
S_NR	14:13	w	Slave Number is given at startup by the external circuit of IFA and IFB and can be changed via SSC-IF Reset: 00 _B
NO_GMR_A	12	ru	No valid GMR Angle Value Cyclic check of DSPU output. 0 _B valid GMR angle value on the interface 1 _B no valid GMR angle value on the interface (e.g test vectors) Reset: 0 _B
NO_GMR_XY	11	ru	No valid GMR XY Values Cyclic check of ADC input. 0 _B valid GMR_XY values on the ADC input 1 _B no valid GMR_XY values on the ADC input (e.g. test vectors) Reset: 0 _B
S_ROM	10	r	Status ROM¹⁾ Check of ROM-CRC at startup. After fail DSPU does not start. SPI access possible. 0 _B CRC OK 1 _B CRC fail or running Reset: 0 _B

Specifications

Field	Bits	Type	Description
S_ADCT	9	ru	<p>Status ADC-Test¹⁾ Check of signal path with test vectors. All test vectors at startup tested. Activation in operation via AS_ADCT possible.</p> <p>0_B Test vectors OK 1_B Test vectors out of limit Reset: 0_B</p>
S_MAGOL	7	ru	<p>Status Magnitude Out of Limit¹⁾ Cyclic check of available magnetic field strength. Deactivation via AS_VEC_MAG.</p> <p>0_B GMR-magnitude OK 1_B GMR-magnitude out of limit Reset: 0_B</p>
S_XYOL	6	ru	<p>Status X,Y Data Out of Limit¹⁾ Cyclic check of X and Y raw values. Deactivation via AS_VEC_XY</p> <p>0_B X,Y data OK 1_B X,Y data out of limit (>23230 digits) Reset: 0_B</p>
S_OV	5	ru	<p>Status Overflow¹⁾ Cyclic check of DSPU overflow. Deactivation via AS_OV.</p> <p>0_B No DSPU overflow occurred 1_B DSPU overflow occurred Reset: 0_B</p>
S_DSPU	4	ru	<p>Status Digital Signal Processing Unit Check of DSPU, CORDIC and CAPCOM at startup. Activation in operation via AS_DSPU possible.</p> <p>0_B DSPU self-test OK 1_B DSPU self-test not OK, or self-test is running Reset: 0_B</p>
S_FUSE	3	ru	<p>Status Fuse CRC¹⁾ Cyclic CRC check of laser-cut-fuses. Deactivation via AS_FUSE and disabled by activated autocalibration.</p> <p><i>Note: Changing of fused parameters results in new CRC, which differs from stored CRC --> Fuse CRC fail</i></p> <p>0_B Fuse CRC OK 1_B Fuse CRC fail Reset: 0_B</p>
S_VR	2	ru	<p>Status Voltage Regulator¹⁾ Permanent check of internal and external supply voltages. Deactivation via AS_VR</p> <p>0_B Voltages OK 1_B V_{DD} overvoltage; V_{DD} undervoltage; V_{DD}-off; GND-off; or V_{OVG}; V_{OVA}; V_{OVD} too high Reset: 0_B</p>

Field	Bits	Type	Description
S_WD	1	ru	Status Watchdog Permanent check of watchdog. After overflow, a reset is necessary. Deactivation via AS_WD 0 _B after chip reset 1 _B watchdog counter expired (DSPU stop), AS_RST must be activated Reset: 0 _B
S_RST	0	ru	Status Reset Permanent check of any reset. Deactivation via AS_RST. 0 _B no reset since last readout 1 _B indication of power-up, short power-break or active reset Reset: 1 _B

1) Reset to "0" after readout

Activation Status Register

ACSTAT	Offset	Reset Value
Activation Status Register	01_H	5EFE_H

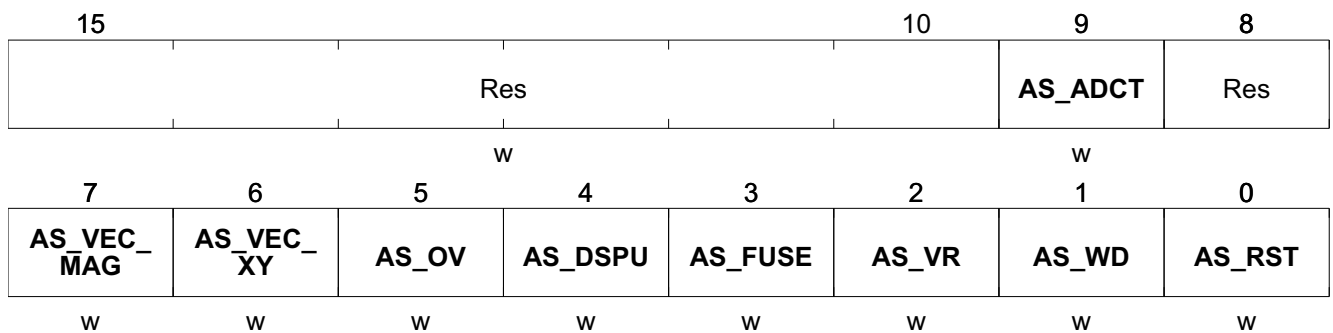

Field	Bits	Type	Description
Res	15:10	w	Reserved Reset: 010111 _B
AS_ADCT	9	w	Enable ADC Testvector Check 0 _B after execution 1 _B activation of ADC Testvector Check Reset: 1 _B
AS_VEC_MAG	7	w	Activation of Magnitude Check 0 _B monitoring of magnitude disabled 1 _B monitoring of magnitude enabled Reset: 1 _B

Specifications

Field	Bits	Type	Description
AS_VEC_XY	6	w	Activation of X,Yout of limit Check 0 _B monitoring of X,Y out of limit disabled 1 _B monitoring of X,Y out of limit enabled Reset: 1 _B
AS_OV	5	w	Enable of DSPU Overflow Check 0 _B monitoring of DSPU Overflow disabled 1 _B monitoring of DSPU Overflow enabled Reset: 1 _B
AS_DSPU	4	w	Activation DSPU BIST 0 _B after execution 1 _B activation of DSPU BIST or BIST running Reset: 1 _B
AS_FUSE	3	w	Activation Fuse CRC 0 _B monitoring of Fuse CRC disabled 1 _B monitoring of Fuse CRC enabled Reset: 1 _B
AS_VR	2	w	Enable Voltage Regulator Check 0 _B check of regulator voltages disabled 1 _B check of regulator voltages enabled Reset: 1 _B
AS_WD	1	w	Enable DSPU Watchdog-HW-Reset 0 _B DSPU Watchdog monitoring disabled 1 _B DSPU Watchdog monitoring enabled Reset: 1 _B
AS_RST	0	w	Activation of Hardware Reset Activation occurs after CSQ switches from '0' to '1' after SSC transfer. 0 _B after execution 1 _B activation of HW Reset Reset: 0 _B

Angle Value Register

AVAL Offset
Angle Value Register 02_H Reset Value
8000_H

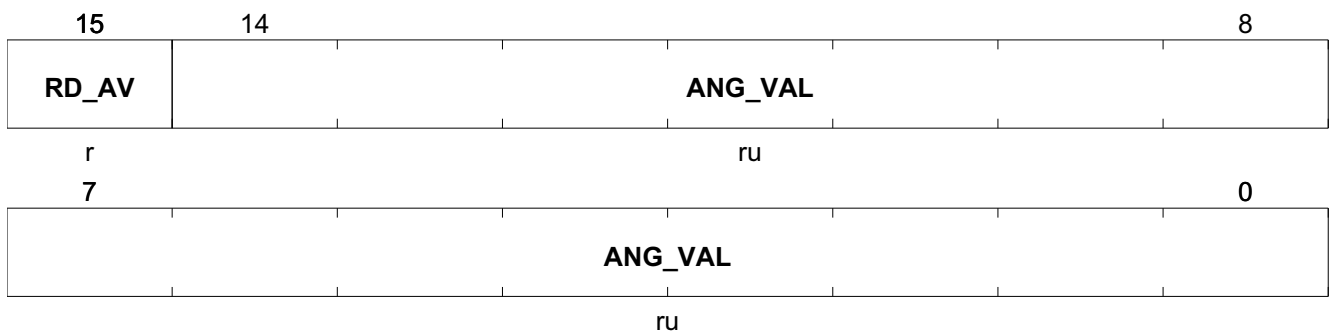

Field	Bits	Type	Description
RD_AV	15	r	Read Status, Angle Value 0 _B no new angle value since last readout 1 _B new angle value (ANG_VAL) present Reset: 1 _B
ANG_VAL	14:0	ru	Calculated Angle Value (ANG_RANGE = 0x080) $Angle[^\circ] = \frac{360^\circ}{2^{15}} ANG_VAL[digits] \quad (4)$ 4000 _H -180° 0000 _H 0° 3FFF _H +179.99° Reset: 0 _H

Angle Speed Register

ASPD	Offset	Reset Value
Angle Speed Register	03 _H	8000 _H

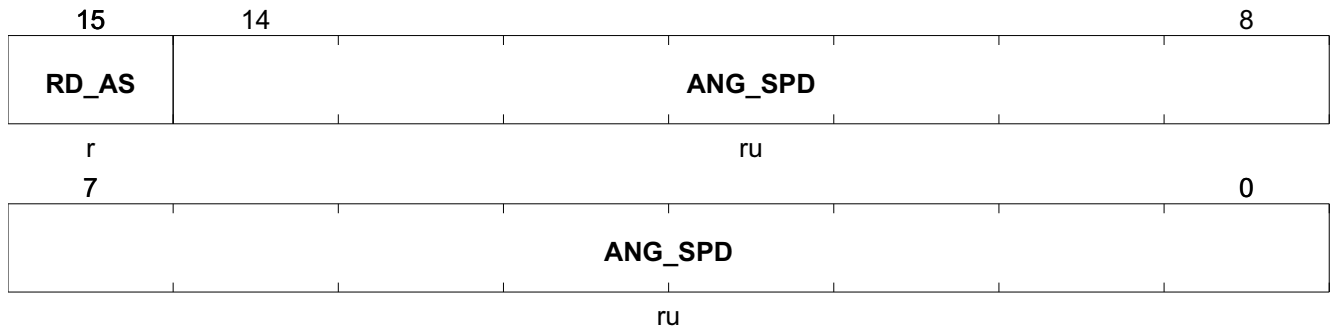

Field	Bits	Type	Description
RD_AS	15	r	Read Status, Angle Speed 0 _B no new angle speed value since last readout 1 _B new angle speed value (ANG_SPD) present Reset: 1 _B
ANG_SPD	14:0	ru	Calculated Angle Speed Without prediction difference among three consecutive angle values. With prediction, difference among three predicted angle values. $Speed [^\circ / s] = \frac{AngleRange [^\circ]}{2^{15}} \frac{ANG_SPD [digits]}{2t_{upd} [s]} \quad (5)$ Reset: 0 _H

Angle Revolution Register

AREV **Offset** **Reset Value**
Angle Revolution Register **04_H** **8000_H**

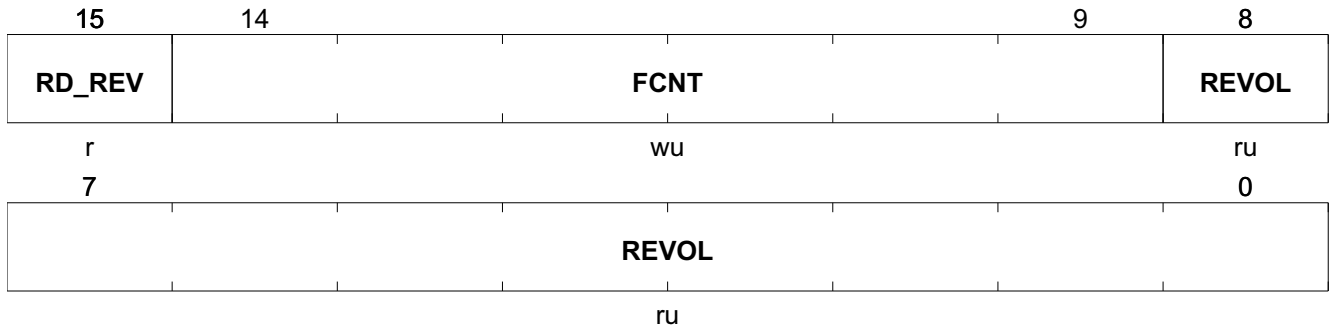

Field	Bits	Type	Description
RD_REV	15	r	Read Status, Revolution 0 _B no new values since last readout 1 _B new value (REVOL) present Reset: 1 _B
FCNT	14:9	wu	Frame Counter (unsigned 6-bit value) Counts every new angle value Reset: 0 _H
REVOL	8:0	ru	Number of Revolutions (signed 9-bit value) If prediction is enabled, revolution counter is one schedule delayed related to ANG_VAL. Reset: 0 _H

Frame Synchronization Register

FSYNC **Offset** **Reset Value**
Frame Synchronization Register **05_H** **0000_H**

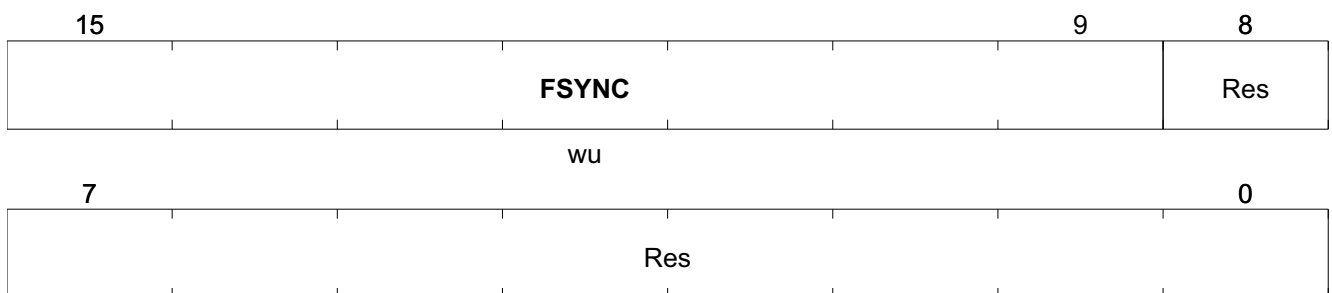

Field	Bits	Type	Description
FSYNC	15:9	wu	Frame Synchronization Counter Value Sub-counter within one frame. Reset: 0 _H

Interface Mode1 Register

MOD_1	Offset	Reset Value
Interface Mode1 Register	06 _H	8001 _H

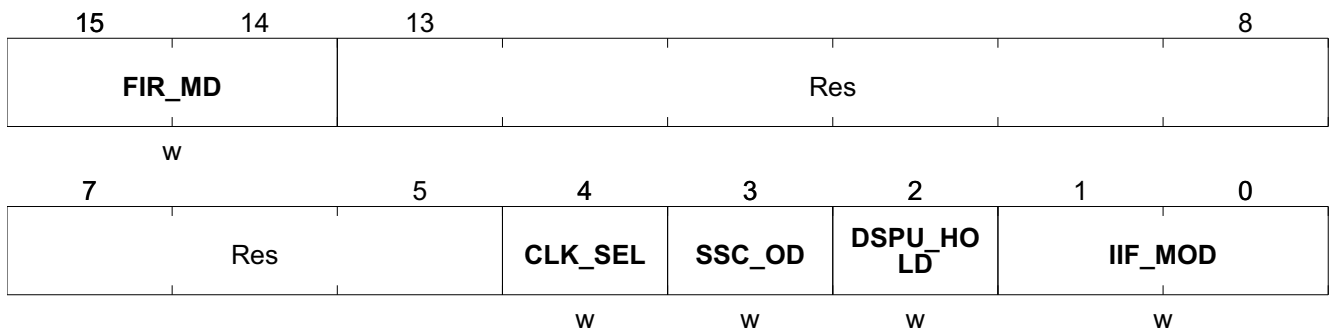

Field	Bits	Type	Description
FIR_MD	15:14	w	Filter Decimation Setting (Update Rate Setting) 00 _B 21.3 μs (only for raw X/Y-values) 01 _B 42.7 μs 10 _B 85.3 μs 11 _B 170.6 μs Reset: 10 _B
CLK_SEL	4	w	Clock Source Select In absence of external clock or PLL out of lock, automatically switch to internal oscillator 0 _B internal oscillator 1 _B external 4-MHz clock Reset: 0 _B
SSC_OD	3	w	SSC Interface 0 _B Push-pull 1 _B Open drain (default within TLE5012-E0318 and TLE5012-E0742) Reset: 0 _B

Field	Bits	Type	Description
DSPU_HOLD	2	w	Hold DSPU Operation If DSPU is on hold, no WD reset is performed by DSPU. Deactivate watchdog with AS_WD before setting DSPU on hold. 0_B DSPU in normal schedule operation 1_B DSPU is on hold Reset: 0_B
IIF_MOD	1:0	w	Incremental Interface Mode 00_B IIF disabled 01_B A/B operation with Index on DATA 10_B Step/Direction operation with Index on DATA 11_B not allowed Reset: 01_B

SIL Register

SIL SIL Register	Offset 07_H	Reset Value 0000_H																																										
<table border="0"> <tr> <td style="text-align: right;">15</td> <td style="text-align: center;">14</td> <td style="text-align: center;">13</td> <td style="text-align: center;">11</td> <td style="text-align: center;">10</td> <td style="text-align: center;">9</td> <td style="text-align: center;">8</td> </tr> <tr> <td style="border: 1px solid black; padding: 2px;">FILT_PA R</td> <td style="border: 1px solid black; padding: 2px;">FILT_IN V</td> <td style="border: 1px solid black; padding: 2px; text-align: center;">Res</td> <td style="border: 1px solid black; padding: 2px; text-align: center;">Res</td> <td style="border: 1px solid black; padding: 2px;">FUSE_RE L</td> <td style="border: 1px solid black; padding: 2px; text-align: center;">Res</td> <td style="border: 1px solid black; padding: 2px;"></td> </tr> <tr> <td style="text-align: center;">w</td> <td style="text-align: center;">w</td> <td colspan="2"></td> <td style="text-align: center;">w</td> <td colspan="2"></td> </tr> <tr> <td style="text-align: center;">7</td> <td style="text-align: center;">6</td> <td style="text-align: center;">5</td> <td style="text-align: center;">3</td> <td style="text-align: center;">2</td> <td colspan="2" style="text-align: center;">0</td> </tr> <tr> <td style="border: 1px solid black; padding: 2px; text-align: center;">Res</td> <td style="border: 1px solid black; padding: 2px;">ADCTV_E N</td> <td colspan="2" style="border: 1px solid black; padding: 2px; text-align: center;">ADCTV_Y</td> <td colspan="3" style="border: 1px solid black; padding: 2px; text-align: center;">ADCTV_X</td> </tr> <tr> <td></td> <td style="text-align: center;">w</td> <td colspan="2" style="text-align: center;">w</td> <td colspan="3" style="text-align: center;">w</td> </tr> </table>	15	14	13	11	10	9	8	FILT_PA R	FILT_IN V	Res	Res	FUSE_RE L	Res		w	w			w			7	6	5	3	2	0		Res	ADCTV_E N	ADCTV_Y		ADCTV_X				w	w		w				
15	14	13	11	10	9	8																																						
FILT_PA R	FILT_IN V	Res	Res	FUSE_RE L	Res																																							
w	w			w																																								
7	6	5	3	2	0																																							
Res	ADCTV_E N	ADCTV_Y		ADCTV_X																																								
	w	w		w																																								

Field	Bits	Type	Description
FILT_PAR	15	w	Filter Parallel 0_B filter parallel disabled 1_B filter parallel enabled (source: X-value) Reset: 0_B
FILT_INV	14	w	Filter Inverted 0_B filter inverted disabled 1_B filter inverted enabled Reset: 0_B
FUSE_REL	10	w	Fuse Reload 0_B fuse reload disabled 1_B fuse parameters reloaded to DSPU at next cycle start Reset: 0_B

Field	Bits	Type	Description
ADCTV_EN	6	w	ADC-Test vectors 0 _B ADC-Test vectors disabled 1 _B ADC-Test vectors enabled Reset: 0 _B
ADCTV_Y	5:3	w	Test vector Y 000 _B 0V 001 _B +70% 010 _B +100% 011 _B +Overflow 101 _B -70% 110 _B -100% 111 _B -Overflow Reset: 0 _H
ADCTV_X	2:0	w	Test vector X 000 _B 0V 001 _B +70% 010 _B +100% 011 _B +OV 101 _B -70% 110 _B -100% 111 _B -OV Reset: 0 _H

Interface Mode2 Register

MOD_2	Offset	Reset Value
Interface Mode2 Register	08 _H	0800 _H

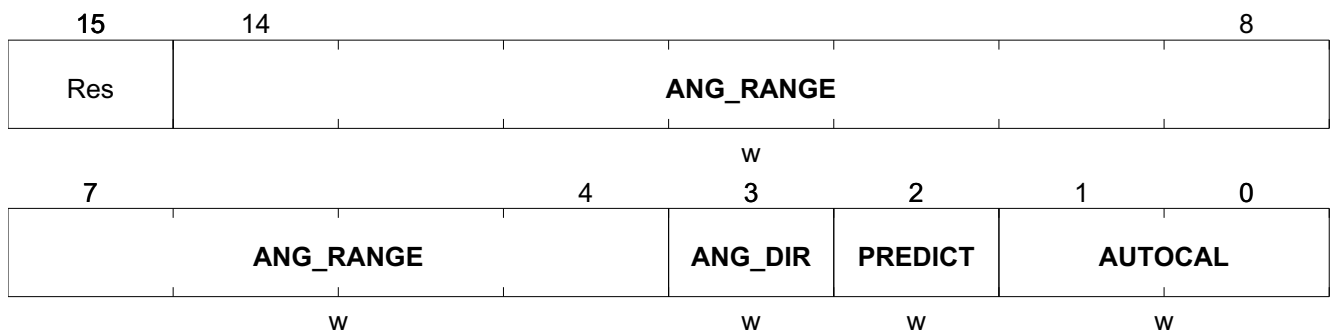

Field	Bits	Type	Description
ANG_RANGE	14:4	w	Angle Range Angle Range [°] = 360° * (2 ⁷ / ANG_RANGE[digits]) 200 _H represents 90° 080 _H represents 360° Reset: 080 _H

Specifications

Field	Bits	Type	Description
ANG_DIR	3	w	Angle Direction 0 _B counterclockwise rotation of magnet 1 _B clockwise rotation of magnet Reset: 0 _B
PREDICT	2	w	Prediction 0 _B prediction disabled 1 _B prediction enabled (default within TLE5012-E0318 and TLE5012-E0742) Reset: 0 _B
AUTOCAL	1:0	w	Autocalibration Mode Autocalibration modes are described on Page 23 . 00 _B no autocalibration 01 _B autocalibration mode 1 (default within TLE5012-E0318 and TLE5012-E0742) 10 _B autocalibration mode 2 11 _B autocalibration mode 3 Reset: 00 _B

Interface Mode3 Register

MOD_3	Offset	Reset Value
Interface Mode3 Register	09 _H	0000 _H

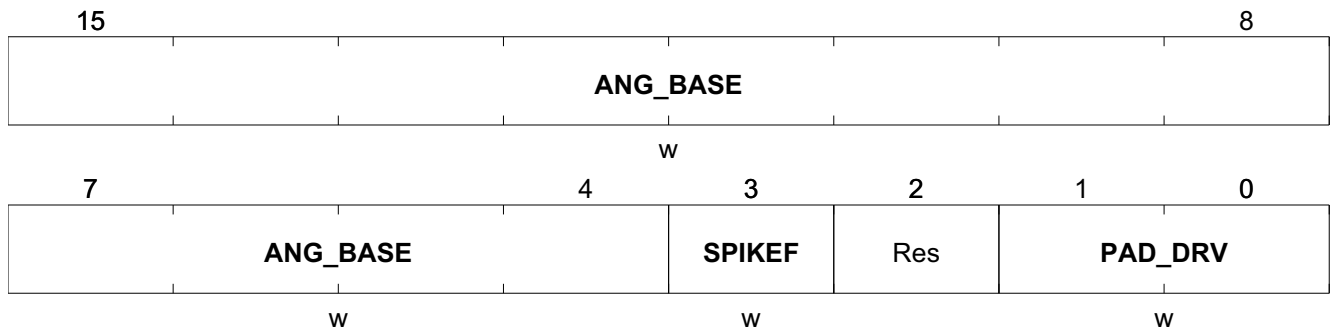

Field	Bits	Type	Description
ANG_BASE	15:4	w	Angle Base 800 _H -180° 000 _H 0° 001 _H 0.0879° 7FF _H +179.912° Reset: 000 _H
SPIKEF	3	w	Analog Spike Filters of Input Pads 0 _B spike filter disabled 1 _B spike filter enabled Reset: 0 _B

Field	Bits	Type	Description
PAD_DRV	1:0	w	Configuration of Pad-Driver 00 _B IFA/IFB: strong driver, DATA: strong driver, fast edge 01 _B IFA/IFB: strong driver, DATA: strong driver, slow edge 10 _B IFA/IFB: weak driver, DATA: medium driver, fast edge (default within TLE5012-E0318 and TLE5012-E0742) 11 _B IFA/IFB: weak driver, DATA: weak driver, slow edge Reset: 00 _B

Offset X Register

OFFX	Offset	Reset Value
Offset X	0A_H	0000_H

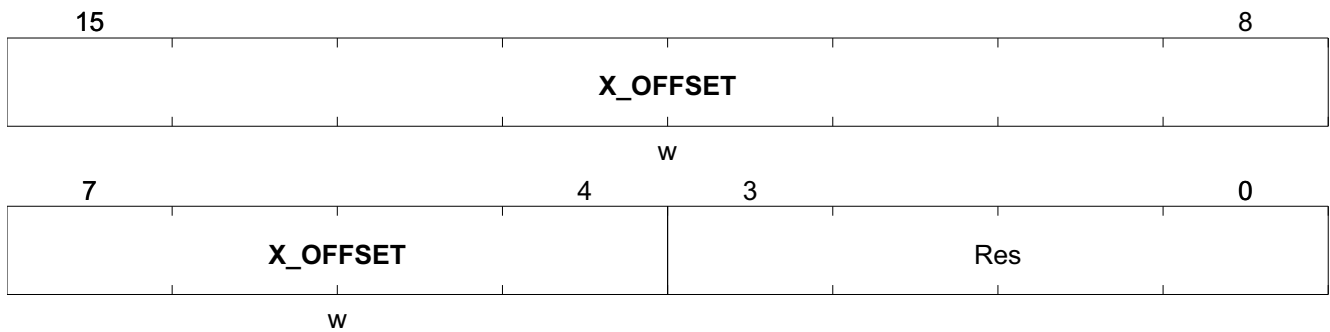

Field	Bits	Type	Description
X_OFFSET	15:4	w	Offset Correction of X-value in digits Reset: 0 _H

IFAB Register

IFAB	Offset	Reset Value
IFAB Register	0D_H	0003_H

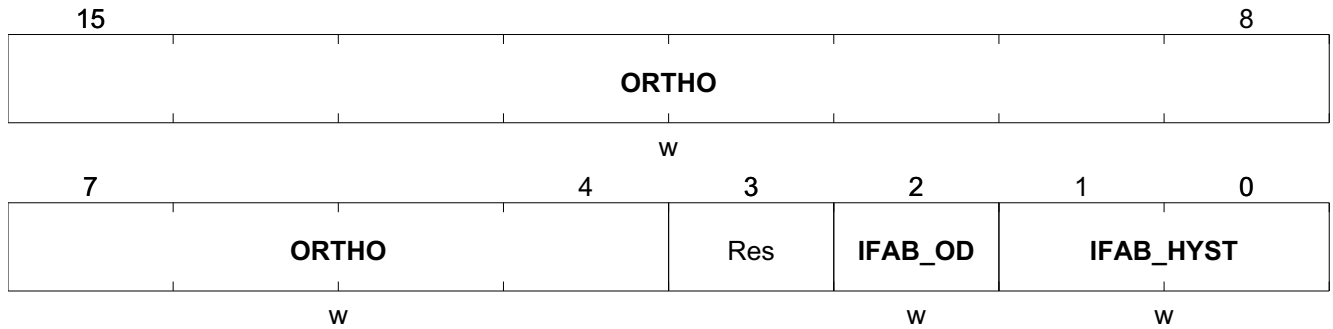

Field	Bits	Type	Description
ORTHO	15:4	w	Orthogonality Correction of X and Y Components $+2047_{\text{D}} \quad 11.2445^{\circ}$ $0_{\text{D}} \quad 0^{\circ}$ $-2048_{\text{D}} \quad -11.2500^{\circ}$ Reset: 0_{H}
IFAB_OD	2	w	IFA & IFB Open Drain 0_{B} Push-pull 1_{B} Open drain (default within TLE5012-E0318 and TLE5012-E0742) Reset: 0_{B}
IFAB_HYST	1:0	w	HSM Hysteresis $00_{\text{B}} \quad 0^{\circ}$ $01_{\text{B}} \quad 0.09^{\circ}$ $10_{\text{B}} \quad 0.27^{\circ}$ $11_{\text{B}} \quad 0.625^{\circ}$ Reset: 11_{B}

Interface Mode4 Register

MOD_4	Offset	Reset Value
Interface Mode4 Register	0E _H	0000 _H

15	TCO_X_T			9	8
7	5	4	3	2	0
HSM_PLP		IFAB_RES		IF_MD	
w		w		w	

Field	Bits	Type	Description
TCO_X_T	15:9	w	Offset Temperature Coefficient for X-Component Reset: 0 _H
HSM_PLP	7:5	w	Hall Switch Mode; Pole pair Configuration 000 _B 2 pole pairs 001 _B 3 pole pairs (default within TLE5012-E0318) 010 _B 4 pole pairs 011 _B 6 pole pairs 100 _B 7 pole pairs (default within TLE5012-E0742) 101 _B 8 pole pairs 110 _B 12 pole pairs 111 _B 16 pole pairs Reset: 000 _B
IFAB_RES	4:3	w	IFAB Resolution 00 _B 12 bit = 0.088° (244Hz) 01 _B 11 bit = 0.176° (488Hz) 10 _B 10 bit = 0.352° (977Hz) 11 _B 9 bit = 0.703° (1953Hz) Reset: 00 _B

Field	Bits	Type	Description
IF_MD	2:0	w	<p>Interface Mode Selected by external circuit of CLK pin at Power-On Time. CLK pin connected to V_{DD} --> Incremental Interface is selected; CLK pin connected to GND --> IF_MD stored Interface is used. Switching to another interface during operation needs to stop the DSPU (DSPU_HOLD). <i>Note: Combinations not listed below are not allowed</i></p> <p>000_B SSC mode; IIF 001_B SSC mode; PWM 010_B SSC mode; HSM (default within TLE5012-E0318 and TLE5012-E0742) Reset: 000_B</p>

Temperature Coefficient Register

TCO_Y	Offset	Reset Value
Temperature Coefficient Register	0F _H	0000 _H

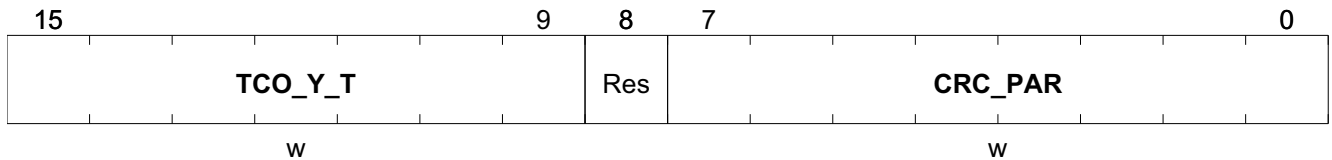

Field	Bits	Type	Description
TCO_Y_T	15:9	w	<p>Offset Temperature Coefficient for Y-Component Reset: 0_H</p>
CRC_PAR	7:0	w	<p>CRC of Parameters CRC of parameters from address 08_H to 0F_H. When changing any settings within these registers, this CRC has to be updated. Reset: 0_H</p>

X-row Value Register

ADC_X	Offset	Reset Value
X-row value	10 _H	0000 _H

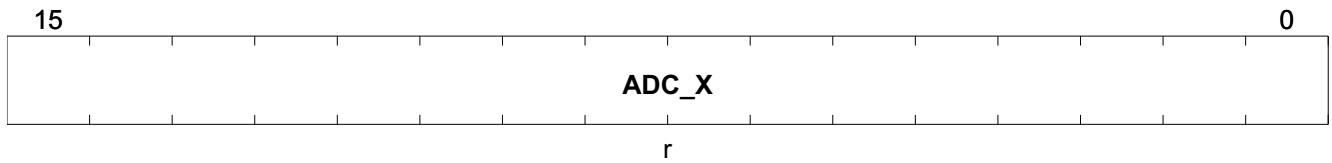

Field	Bits	Type	Description
ADC_X	15:0	r	ADC value of X-GMR Read out of this register will update ADC_Y Reset: 0 _H

Y-row Value Register

ADC_Y	Offset	Reset Value
Y-row value	11 _H	0000 _H

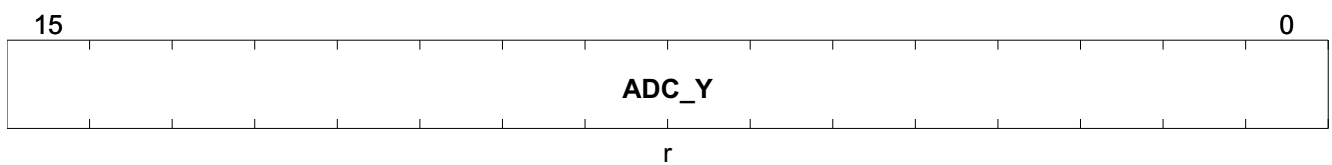

Field	Bits	Type	Description
ADC_Y	15:0	r	ADC value of Y-GMR Updated when ADC_X or ADC_Y is read. Reset: 0 _H

Increment Counter Register

IIF_CNT	Offset	Reset Value
IIF Counter value	20 _H	0000 _H

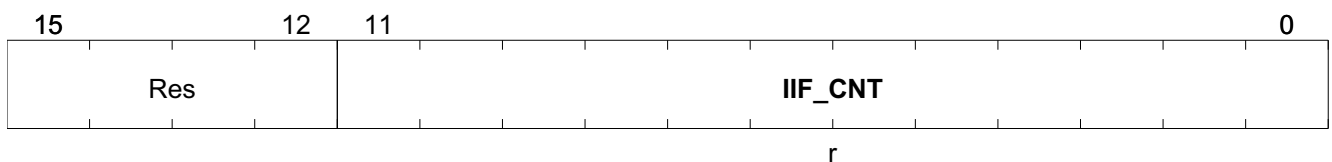

Field	Bits	Type	Description
IIF_CNT	11:0	r	Counter value of increments This value can be used for synchronization purposes between sensor and counter value on microcontroller side. Reset: 0 _H

3.5.1.4 Communication Examples

This section gives some short SPI communication examples. The sensor has to be selected first via CSQ, and SCK must be available for the communication.

Table 19 SSC command to read the angle value

SSC Word No.	Description	Master transmitting	TLE5012 transmitting	Note
1	Command	1_0000_0_000010_0001		
2	Read Data		1_XXXXXXXXXXXXXXXX	Read angle value
3	Safety Word		1_1_1_1_XXXX_XXXXXXXX	Read Safety Word

Table 20 SSC command to read angle speed and angle revolution

SSC Word No.	Description	Master transmitting	TLE5012 transmitting	Note
1	Command	1_0000_0_000011_0010		
2	Read Data		1_XXXXXXXXXXXXXXXX	Read angle speed
3	Read Data		1_XXXXXX_XXXXXXXX	Read angle revolution
4	Safety Word		1_1_1_1_XXXX_XXXXXXXX	Read Safety Word

Table 21 SSC command to change Interface Mode2 register

SSC Word No.	Description	Master transmitting	TLE5012 transmitting	Note
1	Command	0_1010_0_001000_0001		
2	Write Data	0_00010000000_1_0_01		ANG_Range: 080 _H ; ANG_DIR: 1 _B ; PREDICT: 0 _B ; AUTOCAL: 01 _B
3	Safety Word		1_1_1_1_XXXX_XXXXXXXX	Read Safety Word

3.5.2 Pulse-Width Modulation Interface

The Pulse-Width Modulation (PWM) Interface can be selected via SPI.

The PWM update rate can be changed within the register 0E_H (IFAB_RES) in following steps:

- 0.25 kHz with 12-bit resolution
- 0.5 kHz with 12-bit resolution
- 1.0 kHz with 12-bit resolution
- 2.0 kHz with 12-bit resolution

PWM uses a square wave with constant frequency whose duty cycle is modulated, resulting in an average value of the waveform.

Figure 22 shows the principal behavior of a PWM with various duty cycles and the definition of timing values. The duty cycle of a PWM is defined by following general formulas:

$$Duty\ Cycle = \frac{t_{on}}{t_{PWM}}$$

$$t_{PWM} = t_{on} + t_{off}$$

$$f_{PWM} = \frac{1}{t_{PWM}}$$

(6)

The range between 0 - 6.25% and 93.75 - 100% is used only for diagnostic purposes. More details are given in **Table 22**.

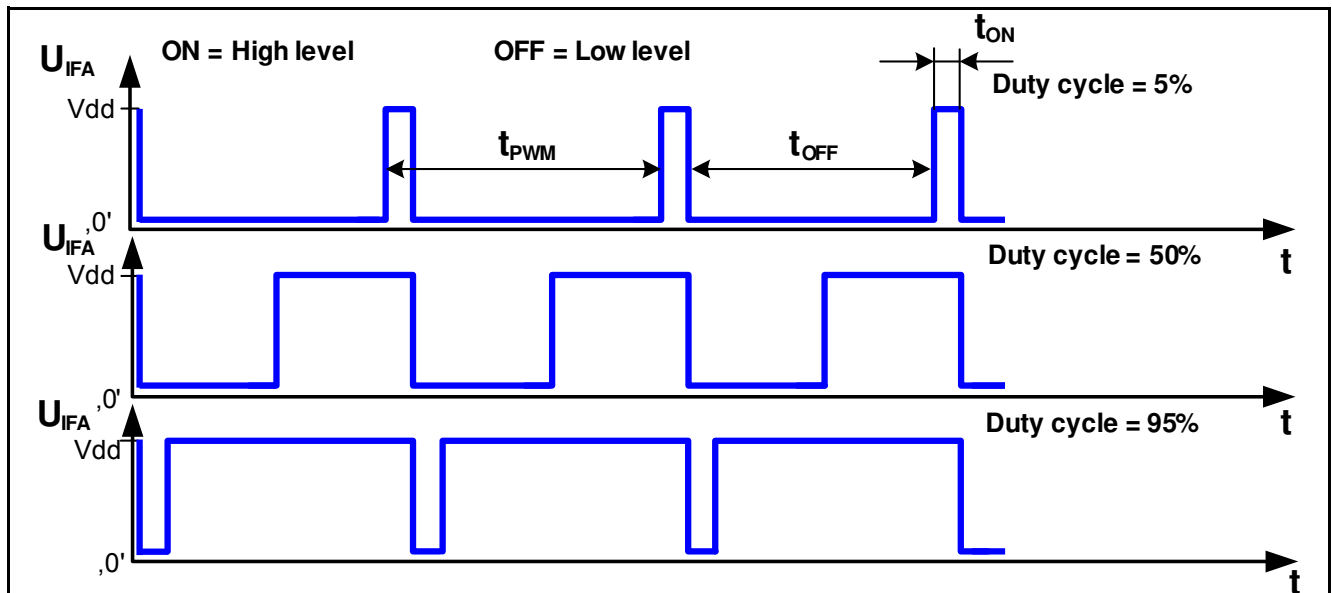

Figure 22 Typical Example for a PWM Signal

Table 22 PWM Interface

Parameter	Symbol	Values			Unit	Note / Test Condition
		Min.	Typ.	Max.		
PWM output frequency	f _{PWM}	244	-	1953	Hz	selectable by IFAB_RES ¹⁾²⁾

Table 22 PWM Interface

Parameter	Symbol	Values			Unit	Note / Test Condition
		Min.	Typ.	Max.		
Output duty cycle range	DY _{PWM}	6.25	-	93.75	%	Absolute angle ²⁾
		-	2	-	%	Electrical error (S_RST; S_VR) ²⁾
		-	98	-	%	System error (S_FUSE; S_OV; S_XYOL; S_MAGOL; S_ADCT) ²⁾
		0	-	1	%	Short to GND ²⁾
		99	-	100	%	Short to V _{DD} , Power-Loss ²⁾
PWM period variation	t _{PWMvar}	-5	-	5	%	²⁾³⁾

1) $f_{PWM} = (f_{DIG} * 2^{IFAB_RES}) / (24 * 4096)$

2) Not subject to production test - verified by design/characterization

3) Depends on internal oscillator frequency variation ([Section 3.4.6](#))

3.5.3 Hall Switch Mode

The Hall Switch Mode (HSM) within the TLE5012 makes it possible to emulate the output of three Hall switches. Hall switches are often used in electrical commutated motors to get information about the rotor position. With these three output signals, the motor will be commutated in the right way. Depending on which pole pairs of the rotor are used, various electrical periods have to be utilized. This is selectable within $0E_H$ (HSM_PLP). Within the TLE5012-E0318 three pole pairs are fused; within the TLE5012-E0742, seven pole pairs are fused. **Figure 23** depicts the three output signals with the relationship between electrical angle and mechanical angle. The mechanical 0° point is always used as a reference.

The HSM is generally used with open-drain output, but it can be changed to push-pull within SSC_OD and IFAB_OD.

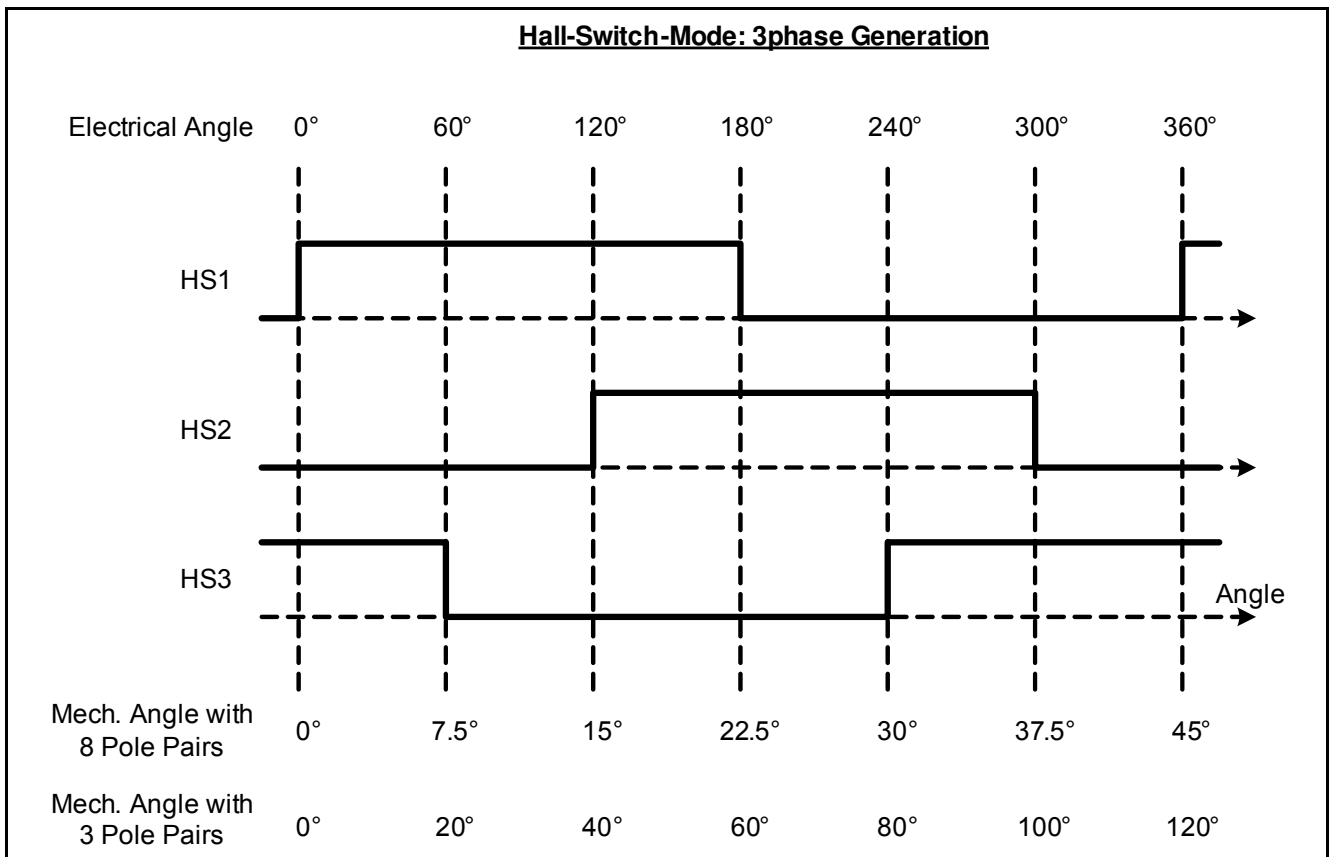

Figure 23 Hall Switch Mode

The HSM Interface can be selected by connecting CLK to GND, and CSQ has to be logic “1”.

Table 23 Hall Switch Mode

Parameter	Symbol	Values			Unit	Note / Test Condition
		Min.	Typ.	Max.		
Rotation speed	n	-	-	10000	rpm	2)

Table 23 Hall Switch Mode

Parameter	Symbol	Values			Unit	Note / Test Condition
		Min.	Typ.	Max.		
Electrical angle accuracy	α_{elect}	-	1.2	2	°	2 pole pairs with autocalibration ¹⁾²⁾
		-	1.8	3		3 pole pairs with autocal. ¹⁾²⁾
		-	2.4	4		4 pole pairs with autocal. ¹⁾²⁾
		-	3.6	6		6 pole pairs with autocal. ¹⁾²⁾
		-	4.2	7		7 pole pairs with autocal. ¹⁾²⁾
		-	4.8	8		8 pole pairs with autocal. ¹⁾²⁾
		-	7.2	12		12 pole pairs with autocal. ¹⁾²⁾
Mechanical angle switching hysteresis	α_{HShystm}	0	-	0.625	°	selectable by IFAB_HYST ²⁾³⁾⁴⁾
		-	1.25	-		2 pole pairs; IFAB_HYST=11 ¹⁾²⁾
Electrical angle switching hysteresis ⁵⁾	α_{HShystel}	-	1.88	-	°	3 pole pairs; IFAB_HYST=11 ¹⁾²⁾
		-	2.50	-		4 pole pairs; IFAB_HYST=11 ¹⁾²⁾
		-	3.75	-		6 pole pairs; IFAB_HYST=11 ¹⁾²⁾
		-	4.38	-		7 pole pairs; IFAB_HYST=11 ¹⁾²⁾
		-	5.00	-		8 pole pairs; IFAB_HYST=11 ¹⁾²⁾
		-	7.50	-		12 pole pairs; IFAB_HYST=11 ¹⁾²⁾
		-	10	-		16 pole pairs; IFAB_HYST=11 ¹⁾²⁾
Fall time	t_{HSfall}	-	0.02	1	µs	$R_L = 2.2 \text{ k}\Omega; C_L < 50 \text{ pF}^{2)}$
Rise time	t_{HSrise}	-	0.4	1	µs	$R_L = 2.2 \text{ k}\Omega; C_L < 50 \text{ pF}^{2)}$

- 1) Depends on internal oscillator frequency variation ([Section 3.4.6](#))
- 2) Not subject to production test - verified by design/characterization
- 3) GMR hysteresis not considered
- 4) Minimum hysteresis without switching
- 5) The hysteresis has to be considered only when rotation direction is changed.

To avoid toggling on the HS outputs during mechanical vibration of the rotor, hysteresis (IFAB_HYST) is recommended ([Figure 24](#)).

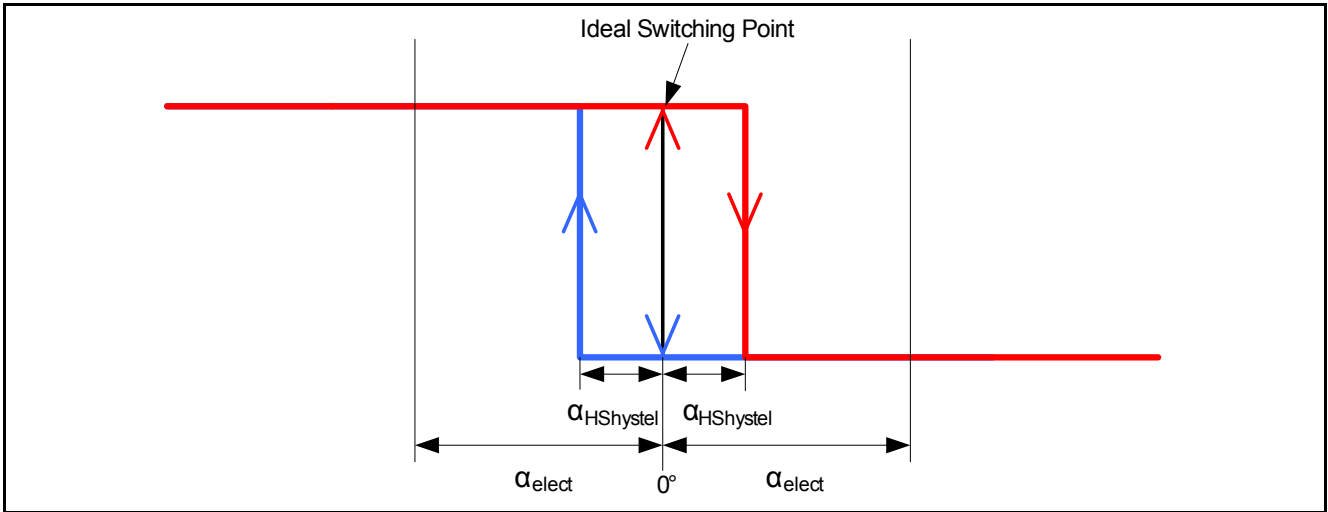

Figure 24 HS hysteresis

3.5.4 Incremental Interface

The Incremental Interface (IIF) uses an up/down counter of a microcontroller for the angle transmission. The synchronization is done by the parallel active SSC Interface. The angle value read out by the SSC Interface can be compared to the stored counter value. In case of a non-synchronization, the microcontroller adds the difference to the actual counter value to synchronize the TLE5012 with the microcontroller. The resolution of the IIF can be selected within the interface mode4 register (MOD_4) under IFAB_RES.

After startup, the IIF pulses out the actual absolute angle value to notify the microcontroller about the absolute position.

In register MOD_1 the IIF can be set in A/B mode or Step/Direction mode (IIF_MOD).

A/B Mode

The phase shift between phase A and B indicates a clockwise (A follows B) or a counterclockwise (B follows A) rotation of the magnet.

Step/Direction Mode

Phase A pulses out the increments and phase B indicates the direction (Figure 25).

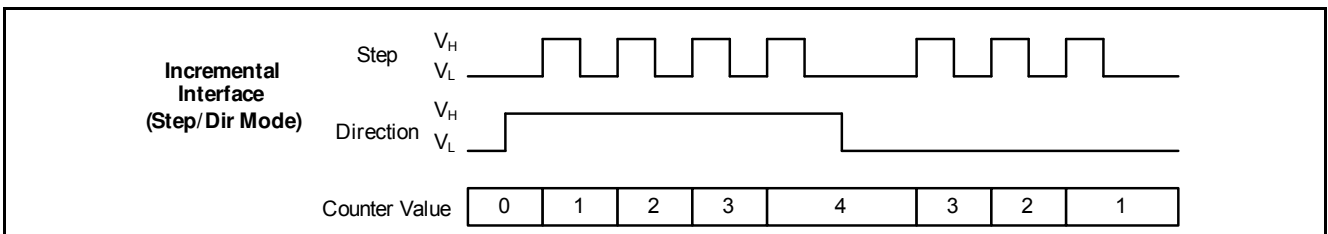

Figure 25 Incremental Interface with Step/Direction mode

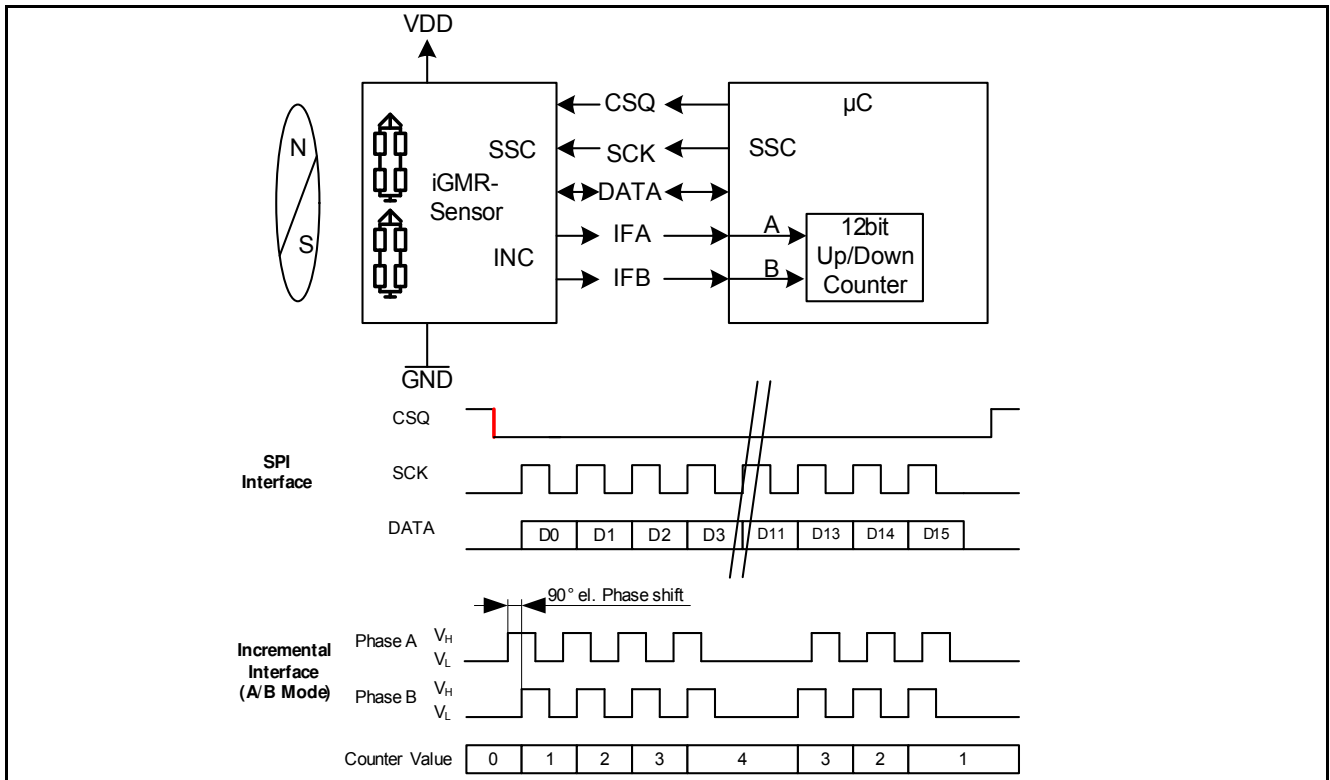

Figure 26 Incremental Interface Protocol with symbolic illustration of SPI Interface

Index Signal

The Index Signal is generated via the Data pin while CSQ is high (no SSC communication). The Index Signal is coded in quadrants via a PWM sequence, [Figure 27](#).

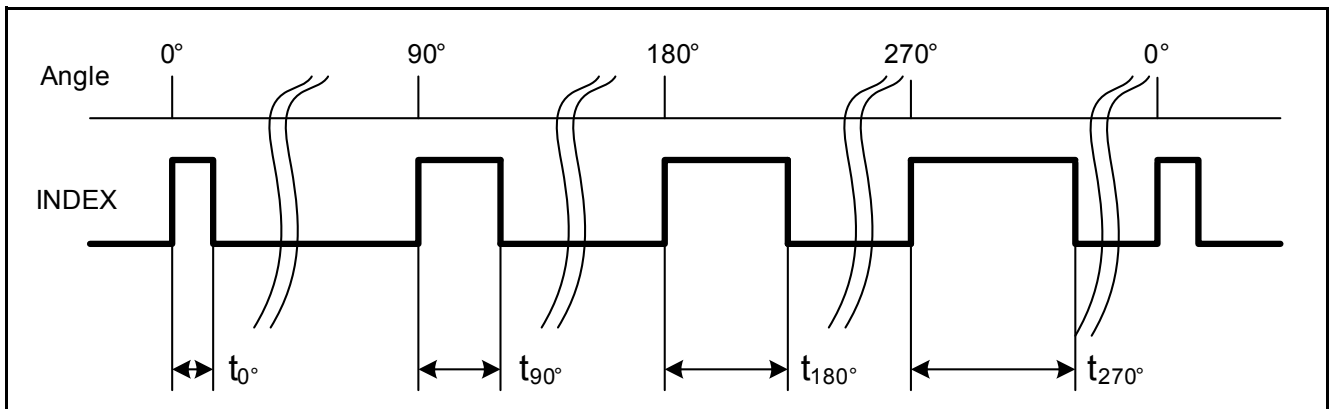

Figure 27 IIF index coding

Table 24 Incremental Interface

Parameter	Symbol	Values			Unit	Note / Test Condition
		Min.	Typ.	Max.		
Incremental output frequency	f_{inc}	-	-	1.0	MHz	Frequency of Phase A and Phase B ¹⁾

Table 24 Incremental Interface (cont'd)

Parameter	Symbol	Values			Unit	Note / Test Condition
		Min.	Typ.	Max.		
Index	t_{0°	-	5	-	μs	0 ¹⁾
	t_{90°	-	10	-	μs	90 ¹⁾
	t_{180°	-	15	-	μs	180 ¹⁾
	t_{270°	-	20	-	μs	270 ¹⁾

1) Not subject to production test - verified by design/characterization

3.6 Test Structure

3.6.1 ADC Test Vectors

It is possible to feed the ADCs with appropriate values to simulate a certain magnet position and other GMR effects. This test can be activated within the SIL register (ADCTV_EN). With ADCTV_Y and ADCTV_X the vector length can be adjusted as shown in [Figure 28](#).

The values are generated with resistors on the chip.

The following X/Y ADC values can be programmed:

- 4 points, circle amplitude = 70% (0°, 90°, 180°, 270°)
- 8 points, circle amplitude = 100% (0°, 45°, 90°, 135°, 180°, 225°, 270°, 315°)
- 8 points, circle amplitude = 122.1% (35.3°, 54.7°, 125.3°, 144.7°, 215.3°, 234.7°, 305.3°, 324.7°)
- 4 points, circle amplitude = 141.4% (45°, 135°, 225°, 315°)

Note: The 100% values typically correspond to 21700 digits and the 70% values to 15500 digits.

Table 25 ADC Test Vectors

Register bits	X/Y values (decimal)		
	min.	typ.	max.
000		0	
001		15500	
010		21700	
011		32767	
100 ¹⁾		0	
101		-15500	
110		-21700	
111		-32768	

1) Invalid

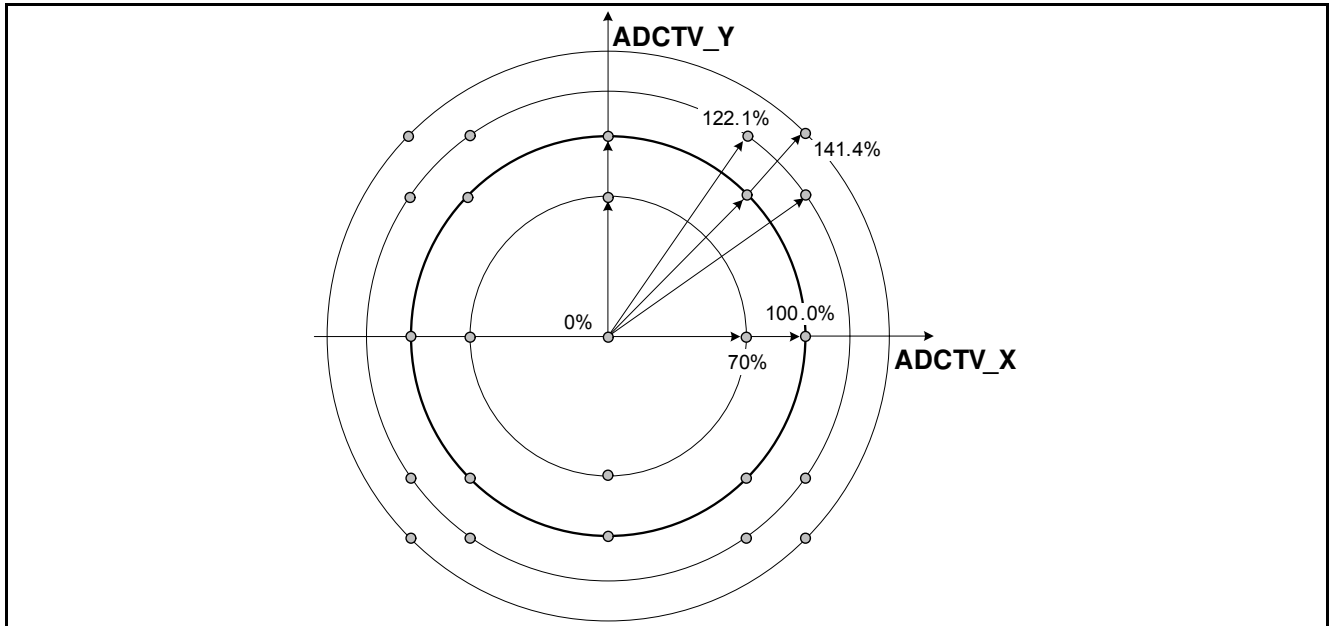

Figure 28 ADC test vectors

Examples for ADC test vector check

The sensor has to be selected first via CSQ and SCK must be available for the communication. [Table 26](#) shows the structure of the communication to enable the ADC test vector for 54.7°.

Table 26 SSC command to enable ADC test vector check

SSC Word No.	Description	Master transmitting	TLE5012 transmitting	Note
1	Command	0_1010_0_000111_0001		
2	Write Data	0_0_000_0_000_1_010_001		check of 54.7°
3	Safety Word		1_1_1_0_XXXX_XXXXXXXXXX	

Table 27 Structure of Write Data for some different test vectors

SSC Word No.	Description	Master transmitting	TLE5012 transmitting	Note
1	Write Data	0_0_000_0_000_1_001_101		~135°
2	Write Data	0_0_000_0_000_1_010_110		~135°
3	Write Data	0_0_000_0_000_1_101_110		~215.3°
4	Write Data	0_0_000_0_000_1_101_000		~270°
5	Write Data	0_0_000_0_000_1_101_010		~324.7°

3.7 Overvoltage Comparators

Various comparators monitor the voltage in order to ensure error-free operation. The overvoltage must be active at least 256 periods of t_{DIG} to set the test comparator bits in the SSC Interface registers. This serves as digital spike suppression.

Table 28 Test comparators

Parameter	Symbol	Values			Unit	Note / Test Condition
		Min.	Typ.	Max.		
Overvoltage Detection	V_{OVG}	-	2.80	-	V	
	V_{OVA}	-	2.80	-	V	
	V_{OVD}	-	2.80	-	V	
V_{DD} Overvoltage	V_{DDOV}	-	6.05	-	V	
V_{DD} Undervoltage	V_{DDUV}	-	2.70	-	V	
GND - Off Voltage	V_{GNDoff}	-	-0.55	-	V	
V_{DD} - Off Voltage	V_{VDDoff}	-	0.55	-	V	
Spike Filter Delay	t_{DEL}	-	10	-	μs	1)

1) Not subject to production test - verified by design/characterization

3.7.1 Internal Supply Voltage Comparators

Every voltage regulator has an overvoltage (OV) comparator to detect a malfunction. If the nominal output voltage of 2.5 V is larger than V_{OVG} , V_{OVA} and V_{OVD} , then this overvoltage comparator is activated.

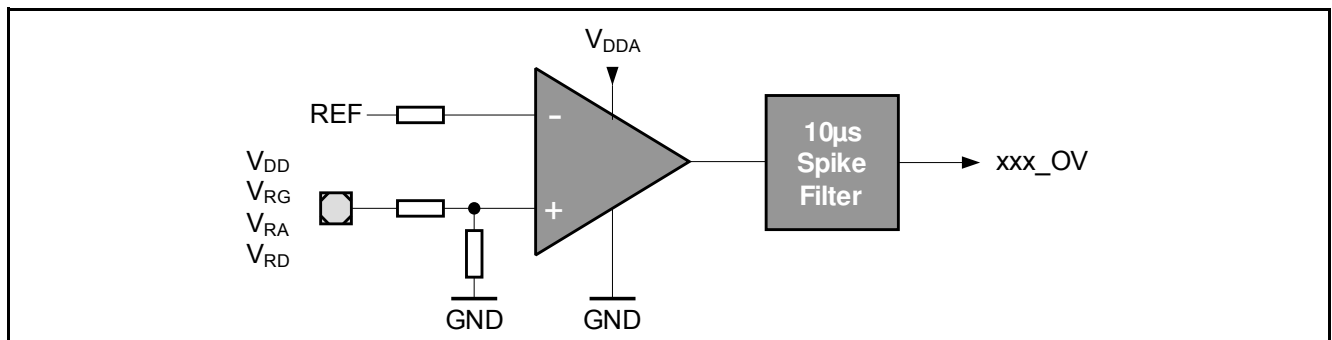

Figure 29 OV comparator

3.7.2 V_{DD} Overvoltage Detection

The Overvoltage Detection comparator monitors the external supply voltage at the V_{DD} pin. It activates the S_VR bit (Figure 29).

3.7.3 GND - Off Comparator

The GND - Off comparator is used to detect a voltage difference between the GND pin and SCK. It activates the S_VR bit of the SSC Interface. This circuit can detect a disconnection of the supply GND pin.

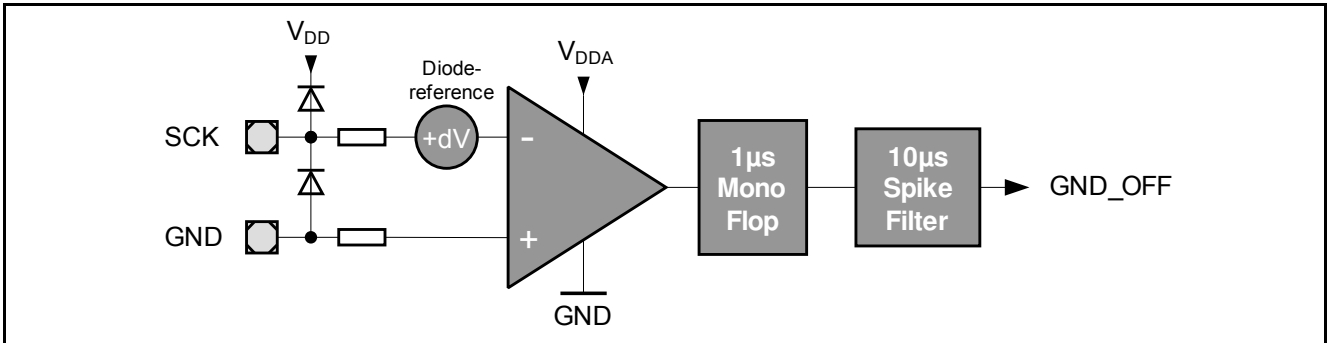

Figure 30 GND - Off comparator

3.7.4 V_{DD} - Off Comparator

The V_{DD} - Off comparator detects a disconnection of the VDD pin supply voltage. In this case, the TLE5012 is supplied by the SCK and CSQ input pins via the ESD structures. It activates the S_VR bit.

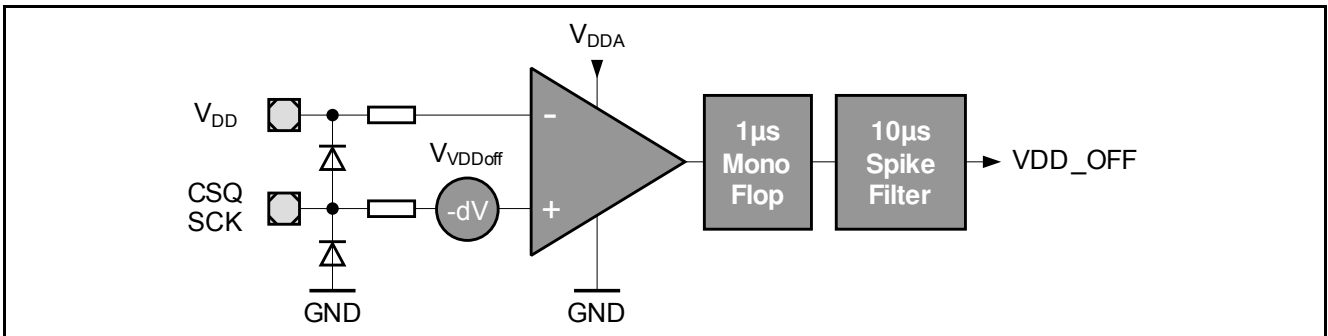

Figure 31 V_{DD} - Off comparator

4 Package Information

4.1 Package Parameters

Table 29 Package parameters

Parameter	Symbol	Limit Values			Unit	Notes
		min.	typ.	max.		
Thermal resistance	R_{thJA}	-	150	200	K/W	Junction to air ¹⁾
	R_{thJC}	-	-	75	K/W	Junction to case
	R_{thJL}	-	-	85	K/W	Junction to lead
Soldering moisture level		MSL 3				260°C
Lead frame		Cu				
Plating		Sn 100%				> 7 μ m

1) According to Jecdec JESD51-7

4.2 Package Outline

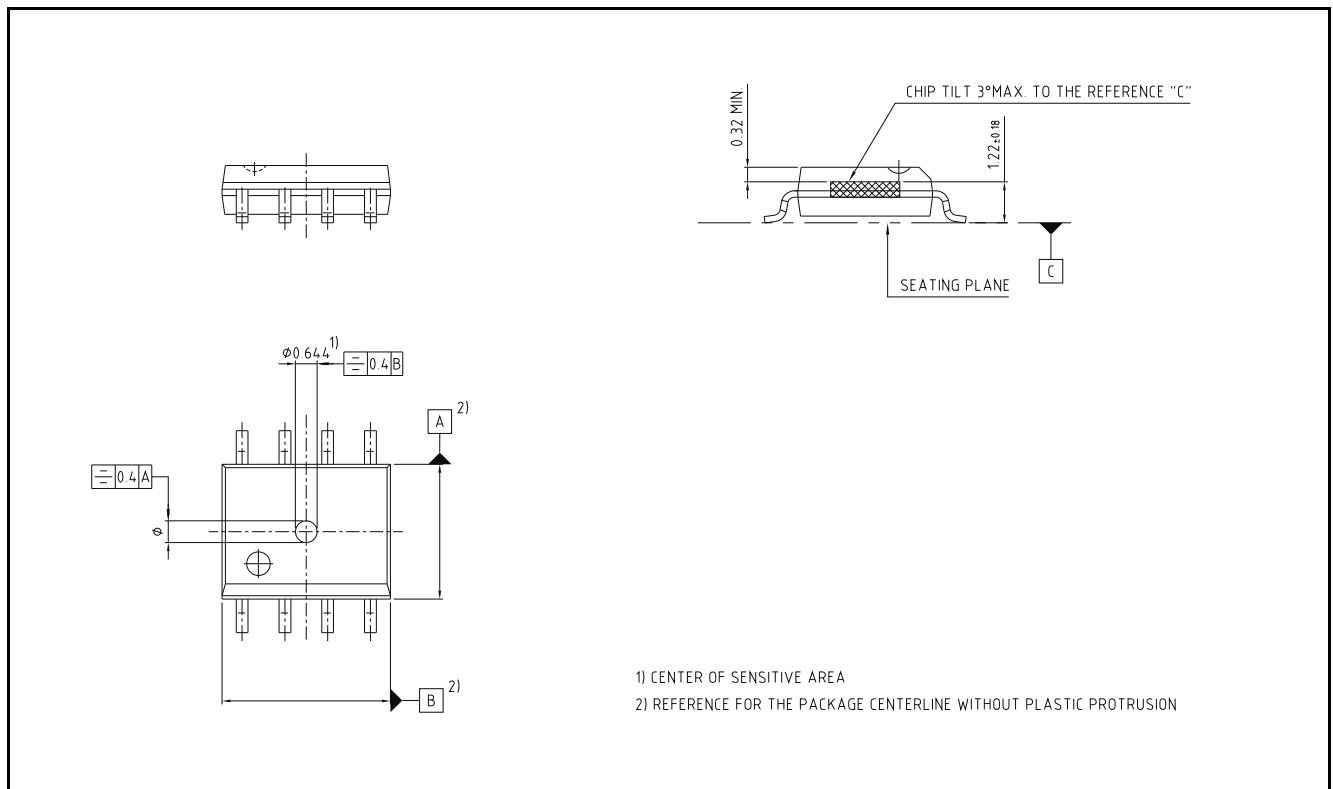

Figure 32 PG-DSO-8 package dimensions

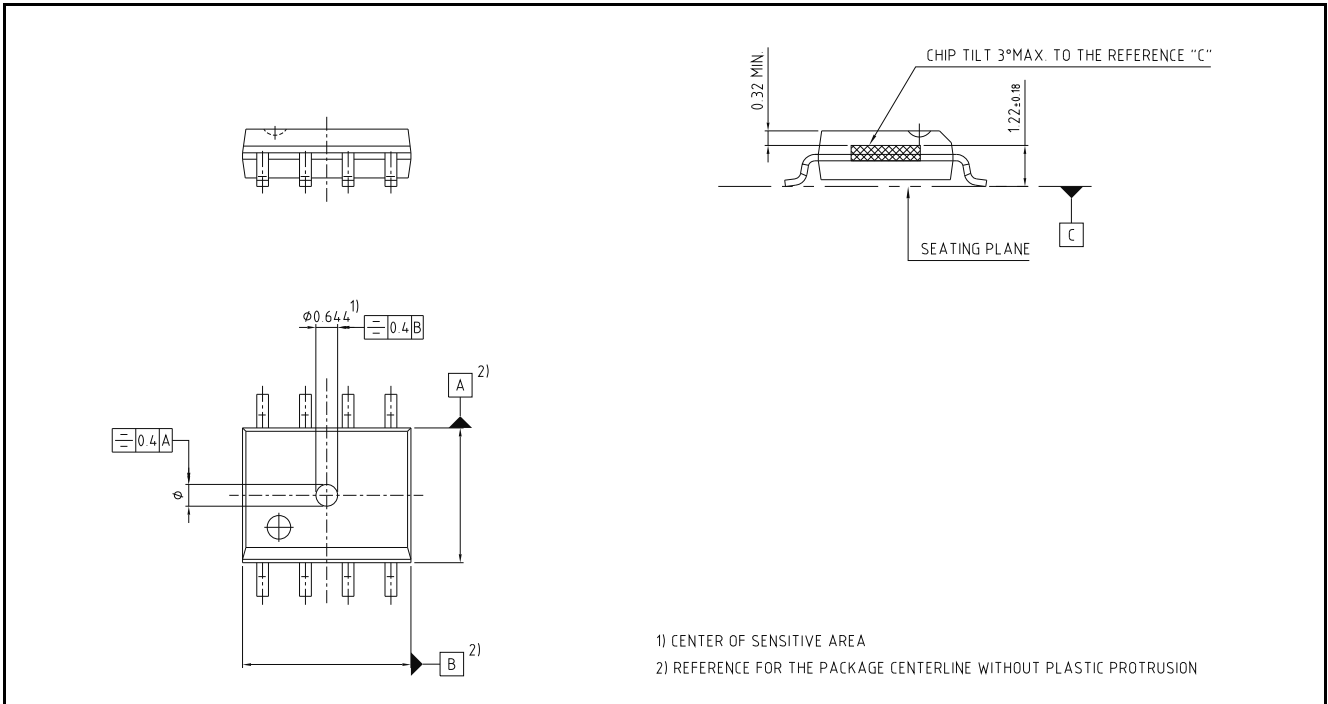

Figure 33 Position of sensing element

4.3 Footprint

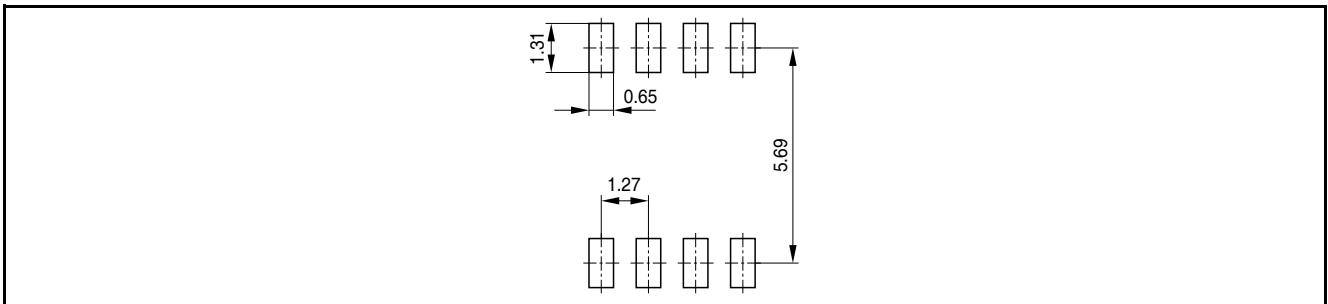

Figure 34 Footprint of PG-DSO-8

4.4 Packing

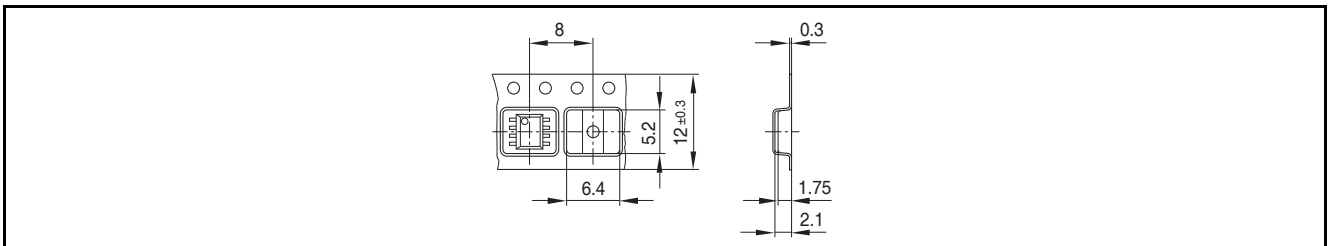

Figure 35 Tape and Reel

4.5 Marking

Position	Marking	Description
1st Line	5012xx	See ordering table on Page 8
2nd Line	xxx	Lot code
3rd Line	Gxxxx	G..green, 4-digit..date code

Processing

Note: For processing recommendations, please refer to Infineon's Notes on processing

www.infineon.com