

SOLDER CHARGE DETAIL

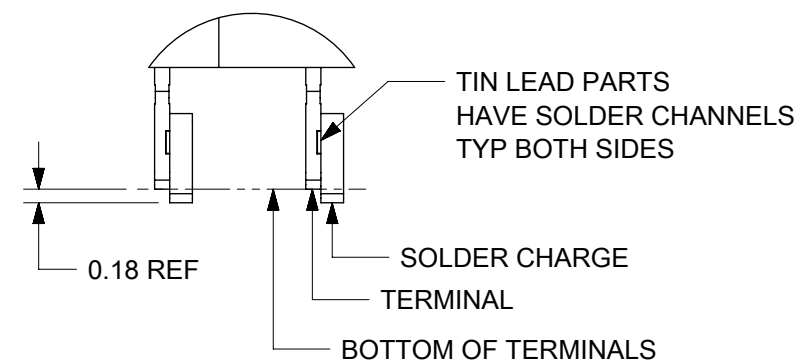

NOTES:

- HOUSING MATERIAL: LCP, GLASS FILLED, UL 94V-0, BLACK  
CONTACT MATERIAL: HIGH PERFORMANCE ALLOY  
SOLDER NAIL MATL: STAINLESS STEEL  
SOLDER CHARGE MATL: SEE TABLE
- FINISH: SELECT GOLD 30 MICRO-INCHES MINIMUM IN CONTACT AREA  
SELECT TIN: 100 MICRO-INCHES MINIMUM IN PCB TAIL  
BOTH OVER NICKEL
- PRODUCT SPEC: PS-45802-001
- COSMETIC SPEC; PS-45499-002 CLASS B
- PACKAGING SPEC: PK-45802-001 MOLEX STANDARD TRAYS  
PK-45802-0002 JEDEC STYLE TRAYS
- DATUM -D- IS THE CENTERLINE OF THE 2 END SLOTS. END SLOT CENTERLINES ARE ESTABLISHED USING 2 MEASUREMENTS FOR EACH SLOT TAKEN 7.20 EITHER SIDE OF DATUM -B-.
- THERE ARE 13 CKTS PER ROW

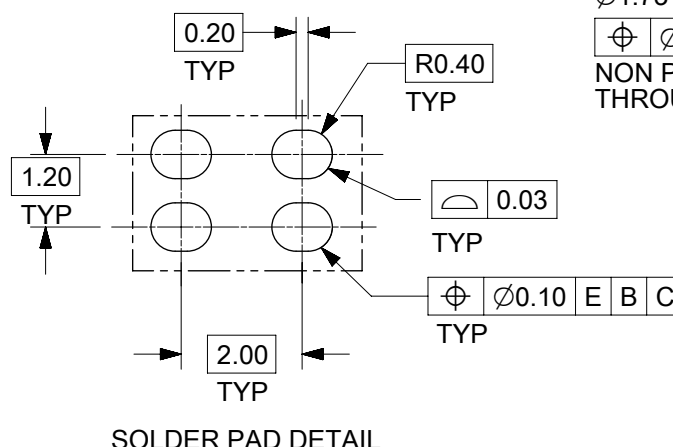
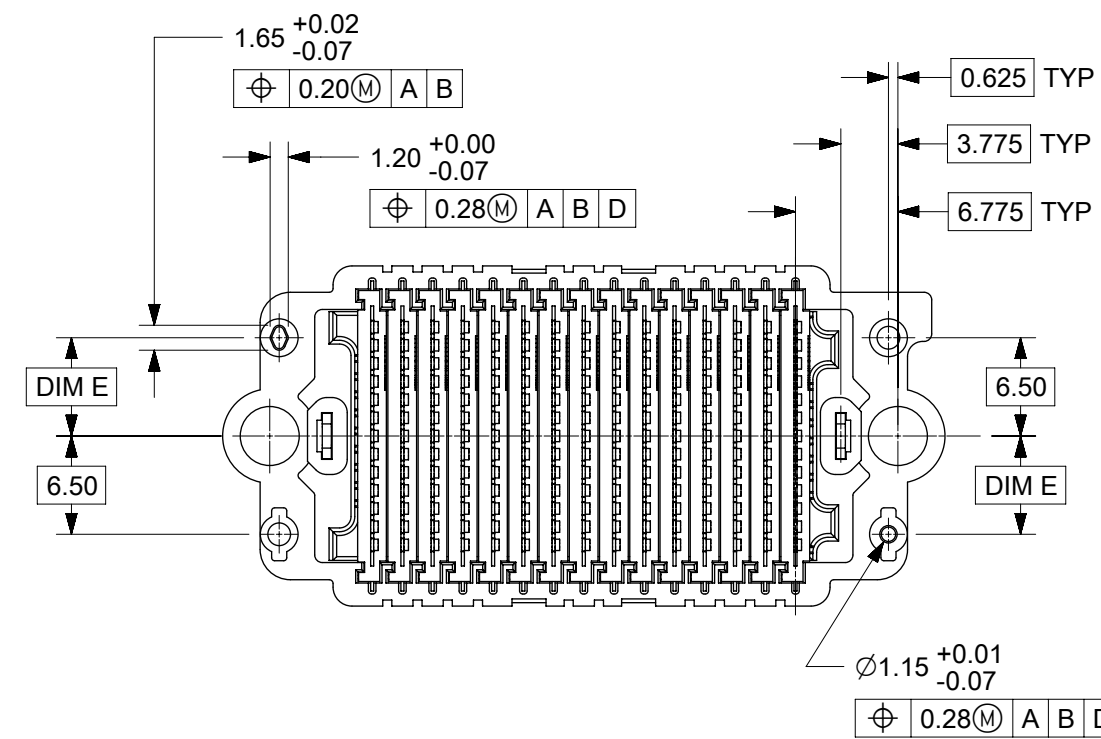
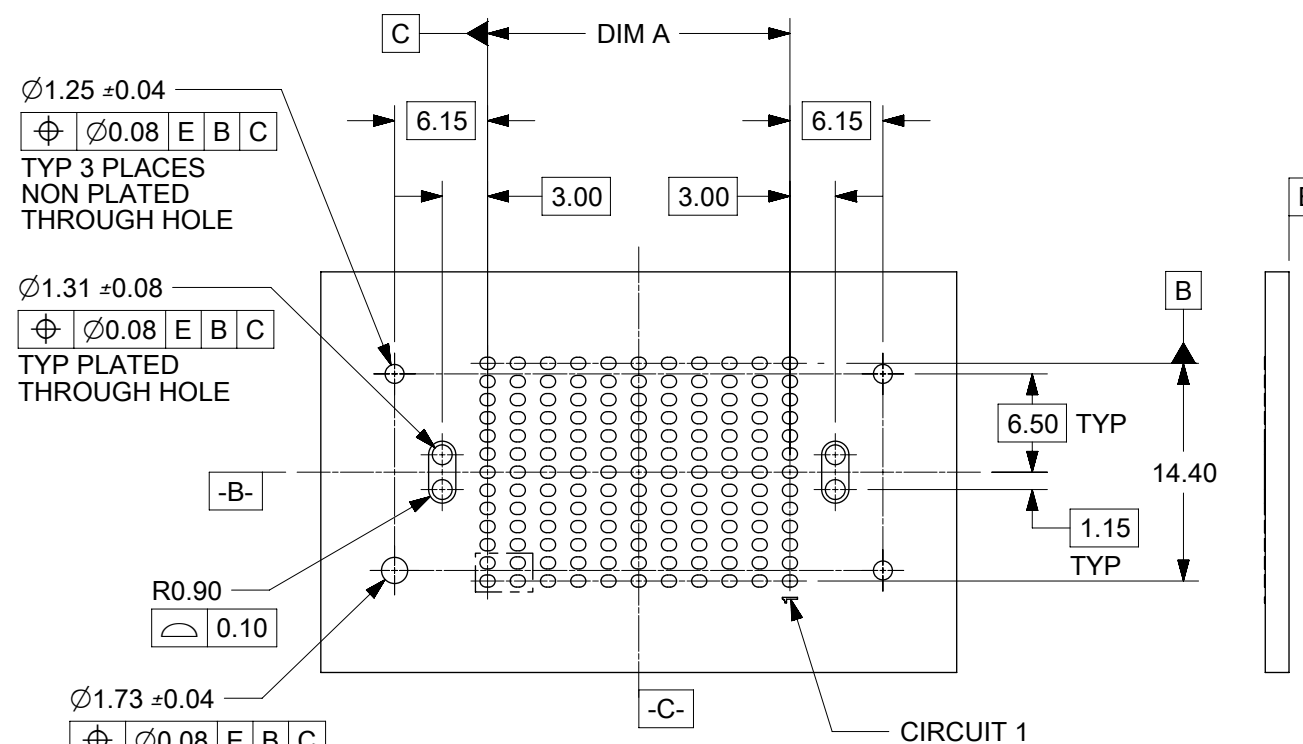
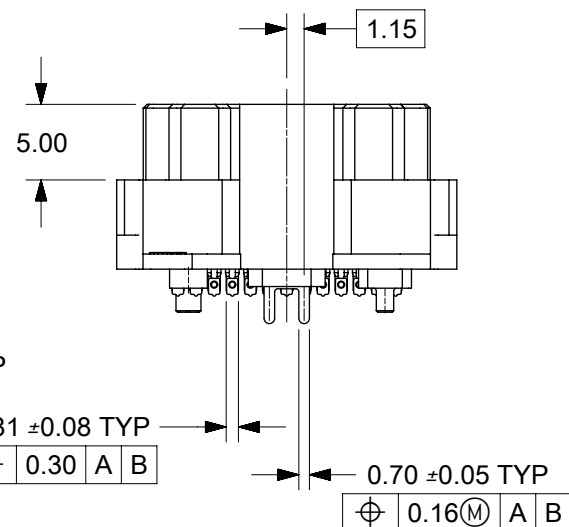
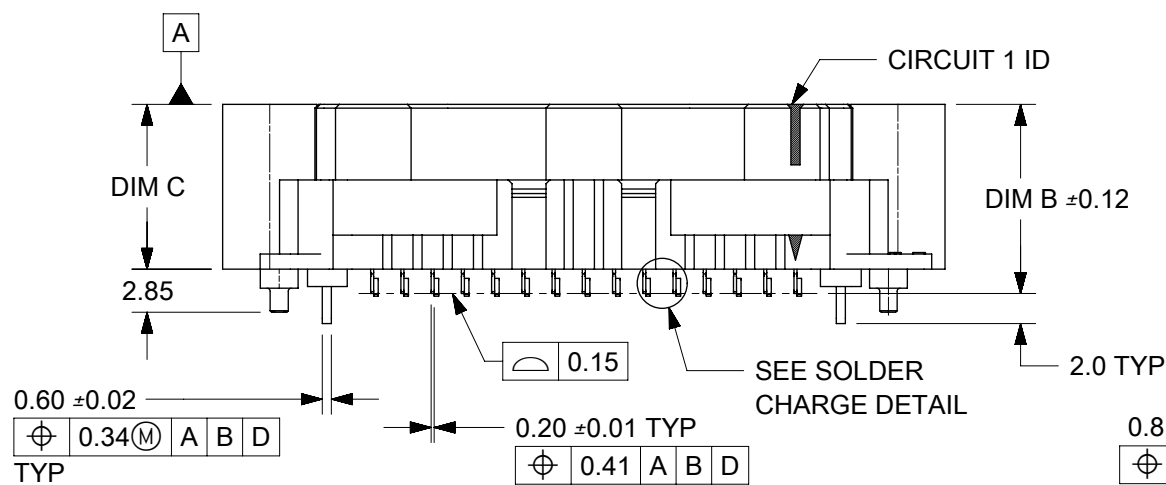

SOLDER PAD DETAIL

PCB LAYOUT: COMPONENT SIDE  
FOR DIM E = 6.50 CONNECTORS  
PCB THICKNESS: NA

THIS DRAWING CONTAINS INFORMATION THAT IS PROPRIETARY TO MOLEX ELECTRONIC TECHNOLOGIES, LLC AND SHOULD NOT BE USED WITHOUT WRITTEN PERMISSION																																										
DIMENSION UNITS		SCALE		CURRENT REV DESC: MIGRATED TO NX																																						
mm		2:1		<table border="1"> <tr> <td colspan="3" rowspan="2"> <b>molex</b> HIGH DENSITY MEZZANINE RECEPTACLE ASSEMBLY         </td> <td colspan="3">PRODUCT CUSTOMER DRAWING</td> </tr> <tr> <td colspan="3">DOCUMENT NUMBER</td> </tr> <tr> <td colspan="3">           EC NO: 617645            DRWN: PMAHADEVAPPA 2019/05/10            CHK'D: DMCGOWAN 2019/05/22            APPR: DMCGOWAN 2019/05/22         </td> <td colspan="3">SD-45802-0001</td> </tr> <tr> <td colspan="3">           INITIAL REVISION:            DRWN: TGREGORI 2010/10/06            APPR: JCOMERCI 2010/10/22         </td> <td colspan="3">PSD 001 J1</td> </tr> <tr> <td colspan="3">           DRAFT WHERE APPLICABLE MUST REMAIN WITHIN DIMENSIONS         </td> <td colspan="3">SHEET NUMBER</td> </tr> <tr> <td colspan="3">           THIRD ANGLE PROJECTION         </td> <td colspan="3">1 OF 4</td> </tr> </table>						<b>molex</b> HIGH DENSITY MEZZANINE RECEPTACLE ASSEMBLY			PRODUCT CUSTOMER DRAWING			DOCUMENT NUMBER			EC NO: 617645 DRWN: PMAHADEVAPPA 2019/05/10 CHK'D: DMCGOWAN 2019/05/22 APPR: DMCGOWAN 2019/05/22			SD-45802-0001			INITIAL REVISION: DRWN: TGREGORI 2010/10/06 APPR: JCOMERCI 2010/10/22			PSD 001 J1			DRAFT WHERE APPLICABLE MUST REMAIN WITHIN DIMENSIONS			SHEET NUMBER			THIRD ANGLE PROJECTION			1 OF 4		
<b>molex</b> HIGH DENSITY MEZZANINE RECEPTACLE ASSEMBLY			PRODUCT CUSTOMER DRAWING																																							
			DOCUMENT NUMBER																																							
EC NO: 617645 DRWN: PMAHADEVAPPA 2019/05/10 CHK'D: DMCGOWAN 2019/05/22 APPR: DMCGOWAN 2019/05/22			SD-45802-0001																																							
INITIAL REVISION: DRWN: TGREGORI 2010/10/06 APPR: JCOMERCI 2010/10/22			PSD 001 J1																																							
DRAFT WHERE APPLICABLE MUST REMAIN WITHIN DIMENSIONS			SHEET NUMBER																																							
THIRD ANGLE PROJECTION			1 OF 4																																							
GENERAL TOLERANCES (UNLESS SPECIFIED)																																										
ANGULAR TOL ± 0.5°																																										
4 PLACES ±																																										
3 PLACES ± 0.05																																										
2 PLACES ± 0.15																																										
1 PLACE ± 0.3																																										
0 PLACES ±																																										
MATERIAL NUMBER		CUSTOMER																																								
SEE TABLE		GENERAL MARKET																																								

			9	8	7	6	5	4	3				
TIN / LEAD PARTS LEAD CODE = "0"	STACK HEIGHT:			8mm	9mm	10mm	11mm	12mm	13mm	14mm	15mm	17mm	18mm
	DIM B:			10.51	11.51	12.51	13.51	14.51	15.51	16.51	17.51	19.51	20.51
	DIM C:			8.90	9.90	10.90	11.90	12.90	13.90	14.90	15.90	17.90	18.90
	ROWS	DIM A	DIM D	MATERIAL NO	MATERIAL NO	MATERIAL NO	MATERIAL NO	MATERIAL NO	MATERIAL NO	MATERIAL NO	MATERIAL NO	MATERIAL NO	MATERIAL NO
	07	12.00	31.89	45802-0007	45802-3007	45802-2007	45802-8007	45802-4007	45802-9007	45802-6007	45802-7007	45802-5007	45802-1007
	09	16.00	35.89	45802-0009	45802-3009	45802-2009	45802-8009	45802-4009	45802-9009	45802-6009	45802-7009	45802-5009	45802-1009
	11	20.00	39.89	45802-0011	45802-3011	45802-2011	45802-8011	45802-4011	45802-9011	45802-6011	45802-7011	45802-5011	45802-1011
	13	24.00	43.89	45802-0013	45802-3013	45802-2013	45802-8013	45802-4013	45802-9013	45802-6013	45802-7013	45802-5013	45802-1013
	15	28.00	47.89	45802-0015	45802-3015	45802-2015	45802-8015	45802-4015	45802-9015	45802-6015	45802-7015	45802-5015	45802-1015
	17	32.00	51.89	45802-0017	45802-3017	45802-2017	45802-8017	45802-4017	45802-9017	45802-6017	45802-7017	45802-5017	45802-1017
	19	36.00	55.89	45802-0019	45802-3019	45802-2019	45802-8019	45802-4019	45802-9019	45802-6019	45802-7019	45802-5019	45802-1019
	21	40.00	59.89	45802-0021	45802-3021	45802-2021	45802-8021	45802-4021	45802-9021	45802-6021	45802-7021	45802-5021	45802-1021
	23	44.00	63.89	45802-0123	45802-3023	45802-2023	45802-8023	45802-4023	45802-9023	45802-6023	45802-7023	45802-5023	45802-1123
25	48.00	67.89	45802-0025	45802-3025	45802-2025	45802-8025	45802-4025	45802-9025	45802-6025	45802-7025	45802-5025	45802-1025	
27	52.00	71.89	45802-0027	45802-3027	45802-2027	45802-8027	45802-4027	45802-9027	45802-6027	45802-7027	45802-5027	45802-1027	

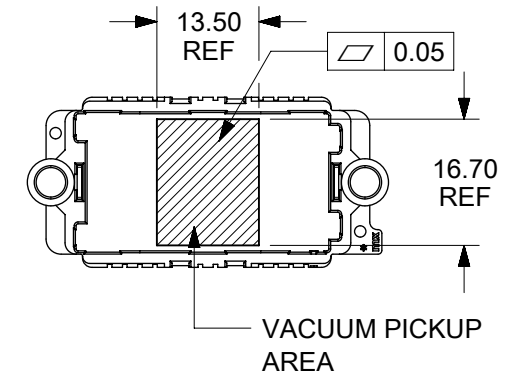

			9	8	7	6	5	4	3				
TIN PARTS LEAD CODE = "2"	STACK HEIGHT:			8mm	9mm	10mm	11mm	12mm	13mm	14mm	15mm	17mm	18mm
	DIM B:			10.51	11.51	12.51	13.51	14.51	15.51	16.51	17.51	19.51	20.51
	DIM C:			8.90	9.90	10.90	11.90	12.90	13.90	14.90	15.90	17.90	18.90
	ROWS	DIM A	DIM D	MATERIAL NO	MATERIAL NO	MATERIAL NO	MATERIAL NO	MATERIAL NO	MATERIAL NO	MATERIAL NO	MATERIAL NO	MATERIAL NO	MATERIAL NO
	07	12.00	31.89	45802-0207	45802-3207	45802-2207	45802-8207	45802-4207	45802-9207	45802-6207	45802-7207	45802-5207	45802-1207
	09	16.00	35.89	45802-0209	45802-3209	45802-2209	45802-8209	45802-4209	45802-9209	45802-6209	45802-7209	45802-5209	45802-1209
	11	20.00	39.89	45802-0311	45802-3211	45802-2211	45802-8211	45802-4211	45802-9211	45802-6211	45802-7211	45802-5211	45802-1211
	13	24.00	43.89	45802-0213	45802-3213	45802-2213	45802-8213	45802-4213	45802-9213	45802-6213	45802-7213	45802-5213	45802-1213
	15	28.00	47.89	45802-0215	45802-3215	45802-2215	45802-8215	45802-4215	45802-9215	45802-6215	45802-7215	45802-5215	45802-1215
	17	32.00	51.89	45802-0217	45802-3217	45802-2217	45802-8217	45802-4217	45802-9217	45802-6217	45802-7217	45802-5217	45802-1217
	19	36.00	55.89	45802-0219	45802-3219	45802-2219	45802-8219	45802-4219	45802-9219	45802-6219	45802-7219	45802-5219	45802-1219
	21	40.00	59.89	45802-0221	45802-3221	45802-2221	45802-8221	45802-4221	45802-9221	45802-6221	45802-7221	45802-5221	45802-1221
	23	44.00	63.89	45802-0223	45802-3223	45802-2223	45802-8223	45802-4223	45802-9223	45802-6223	45802-7223	45802-5223	45802-1223
25	48.00	67.89	45802-0225	45802-3225	45802-2225	45802-8225	45802-4225	45802-9225	45802-6225	45802-7225	45802-5225	45802-1225	
27	52.00	71.89	45802-0227	45802-3227	45802-2227	45802-8227	45802-4227	45802-9227	45802-6227	45802-7227	45802-5227	45802-1227	

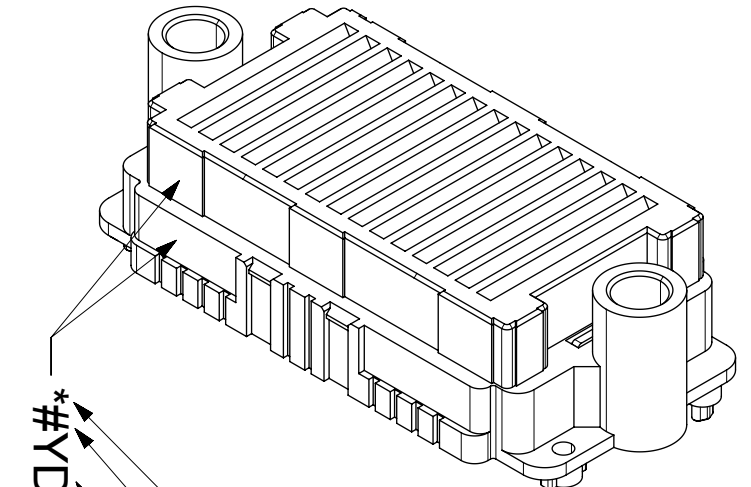

ASSY MACHINE IDENTIFIER  
 LEAD CODE  
 0 = TIN LEAD (Sn63/Pb37)  
 2 = TIN (Sn95.5/Ag3.8/Cu0.7)  
 DATE CODE  
 YEAR - DAY OF YEAR  
 LOCATED APPROX AS SHOWN

PARTS SHOWN ON THIS SHEET  
 HAVE THE FOLLOWING OPTIONS:

DIM E = 6.50  
 PACKAGING: MOLEX STANDARD TRAYS

			9	8	7	6	5	4	3					
NOTE:			1. SOLDER CHARGE COMPOSITION TIN/LEAD: Sn 63/Pb 37 TIN Sn 95.5/ Ag 3.8/ Cu 0.7											
DOCUMENT STATUS	P1	RELEASE DATE	2019/05/22	19:41:30										

THIS DRAWING CONTAINS INFORMATION THAT IS PROPRIETARY TO MOLEX ELECTRONIC TECHNOLOGIES, LLC AND SHOULD NOT BE USED WITHOUT WRITTEN PERMISSION

DIMENSION UNITS	SCALE	CURRENT REV DESC: MIGRATED TO NX	
mm	1:1		
GENERAL TOLERANCES (UNLESS SPECIFIED)			
ANGULAR TOL	± 0.5°	EC NO: 617645	
4 PLACES	±	DRWN: PMAHADEVAPPA	2019/05/10
3 PLACES	± 0.05	CHK'D: DMCGOWAN	2019/05/22
2 PLACES	± 0.15	APPR: DMCGOWAN	2019/05/22
1 PLACE	± 0.3	INITIAL REVISION:	
0 PLACES	±	DRWN: TGREGORI	2010/10/06
DRAFT WHERE APPLICABLE MUST REMAIN WITHIN DIMENSIONS		APPR: JCOMERCI	2010/10/22
THIRD ANGLE PROJECTION	DRAWING	SERIES	MATERIAL NUMBER
	B-SIZE	45802	SEE TABLE
CUSTOMER		REVISION	SHEET NUMBER
GENERAL MARKET		PSD 001	J1 2 OF 4

**molex**  
 HIGH DENSITY MEZZANINE RECEPTACLE ASSEMBLY  
 PRODUCT CUSTOMER DRAWING  
 DOCUMENT NUMBER: SD-45802-0001  
 DOC TYPE: PSD  
 DOC PART: 001  
 REVISION: J1

			9	8	7	6	5	4	3	2	1		
E TIN / LEAD PARTS LEAD CODE = "0"	STACK HEIGHT:			8 mm	9 mm	10 mm	11 mm	12 mm	13 mm	14 mm	15 mm	17 mm	18 mm
	DIM B:			10.51	11.51	12.51	13.51	14.51	15.51	16.51	17.51	19.51	20.51
	DIM C:			8.90	9.90	10.90	11.90	12.90	13.90	14.90	15.90	17.90	18.90
				MATERIAL No	MATERIAL No	MATERIAL No	MATERIAL No	MATERIAL No	MATERIAL No	MATERIAL No	MATERIAL No	MATERIAL No	MATERIAL No
	07	12.00	31.89	45802-0089	45802-3089	45802-2089	45802-8089	45802-4089	45802-9089	45802-6089	45802-7089	45802-5089	45802-1089
	09	16.00	35.89	45802-0090	45802-3090	45802-2090	45802-8090	45802-4090	45802-9090	45802-6090	45802-7090	45802-5090	45802-1090
	11	20.00	39.89	45802-0091	45802-3091	45802-2091	45802-8091	45802-4091	45802-9091	45802-6091	45802-7091	45802-5091	45802-1091
	13	24.00	43.89	45802-0092	45802-3092	45802-2092	45802-8092	45802-4092	45802-9092	45802-6092	45802-7092	45802-5092	45802-1092
	15	28.00	47.89	45802-0093	45802-3093	45802-2093	45802-8093	45802-4093	45802-9093	45802-6093	45802-7093	45802-5093	45802-1093
	17	32.00	51.89	45802-0094	45802-3094	45802-2094	45802-8094	45802-4094	45802-9094	45802-6094	45802-7094	45802-5094	45802-1094
	19	36.00	55.89	45802-0095	45802-3095	45802-2095	45802-8095	45802-4095	45802-9095	45802-6095	45802-7095	45802-5095	45802-1095
	21	40.00	59.89	45802-0096	45802-3096	45802-2096	45802-8096	45802-4096	45802-9096	45802-6096	45802-7096	45802-5096	45802-1096
	23	44.00	63.89	45802-0097	45802-3097	45802-2097	45802-8097	45802-4097	45802-9097	45802-6097	45802-7097	45802-5097	45802-1097
	25	48.00	67.89	45802-0098	45802-3098	45802-2098	45802-8098	45802-4098	45802-9098	45802-6098	45802-7098	45802-5098	45802-1098
27	52.00	71.89	45802-0099	45802-3099	45802-2099	45802-8099	45802-4099	45802-9099	45802-6099	45802-7099	45802-5099	45802-1099	

			9	8	7	6	5	4	3	2	1		
C TIN PARTS LEAD CODE = "2"	STACK HEIGHT:			8 mm	9 mm	10 mm	11 mm	12 mm	13 mm	14 mm	15 mm	17 mm	18 mm
	DIM B			10.51	11.51	12.51	13.51	14.51	15.51	16.51	17.51	19.51	20.51
	DIM C			8.90	9.90	10.90	11.90	12.90	13.90	14.90	15.90	17.90	18.90
				MATERIAL No	MATERIAL No	MATERIAL No	MATERIAL No	MATERIAL No	MATERIAL No	MATERIAL No	MATERIAL No	MATERIAL No	MATERIAL No
	07	12.00	31.89	45802-0289	45802-3289	45802-2289	45802-8289	45802-4289	45802-9289	45802-6289	45802-7289	45802-5289	45802-1289
	09	16.00	35.89	45802-0290	45802-3290	45802-2290	45802-8290	45802-4290	45802-9290	45802-6290	45802-7290	45802-5290	45802-1290
	11	20.00	39.89	45802-0291	45802-3291	45802-2291	45802-8291	45802-4291	45802-9291	45802-6291	45802-7291	45802-5291	45802-1291
	13	24.00	43.89	45802-0292	45802-3292	45802-2292	45802-8292	45802-4292	45802-9292	45802-6292	45802-7292	45802-5292	45802-1292
	15	28.00	47.89	45802-0293	45802-3293	45802-2293	45802-8293	45802-4293	45802-9293	45802-6293	45802-7293	45802-5293	45802-1293
	17	32.00	51.89	45802-0294	45802-3294	45802-2294	45802-8294	45802-4294	45802-9294	45802-6294	45802-7294	45802-5294	45802-1294
	19	36.00	55.89	45802-0295	45802-3295	45802-2295	45802-8295	45802-4295	45802-9295	45802-6295	45802-7295	45802-5295	45802-1295
	21	40.00	59.89	45802-0296	45802-3296	45802-2296	45802-8296	45802-4296	45802-9296	45802-6296	45802-7296	45802-5296	45802-1296
	23	44.00	63.89	45802-0297	45802-3297	45802-2297	45802-8297	45802-4297	45802-9297	45802-6297	45802-7297	45802-5297	45802-1297
	25	48.00	67.89	45802-0298	45802-3298	45802-2298	45802-8298	45802-4298	45802-9298	45802-6298	45802-7298	45802-5298	45802-1298
27	52.00	71.89	45802-0299	45802-3299	45802-2299	45802-8299	45802-4299	45802-9299	45802-6299	45802-7299	45802-5299	45802-1299	

PARTS SHOWN ON THIS SHEET  
HAVE THE FOLLOWING OPTIONS:

DIM E = 6.50  
PACKAGING: JEDEC STYLE TRAYS

THIS DRAWING CONTAINS INFORMATION THAT IS PROPRIETARY TO MOLEX ELECTRONIC TECHNOLOGIES, LLC AND SHOULD NOT BE USED WITHOUT WRITTEN PERMISSION											
DIMENSION UNITS <b>mm</b>		SCALE <b>1:1</b>		CURRENT REV DESC: MIGRATED TO NX							
GENERAL TOLERANCES (UNLESS SPECIFIED)				<b>molex</b>  HIGH DENSITY MEZZANINE RECEPTACLE ASSEMBLY  PRODUCT CUSTOMER DRAWING							
ANGULAR TOL ± 0.5°											
4 PLACES ±											
3 PLACES ± 0.05											
2 PLACES ± 0.15											
1 PLACE ± 0.3											
0 PLACES ±				EC NO: 617645				DRWN: PMAHADEVAPPA 2019/05/10			
DRAFT WHERE APPLICABLE MUST REMAIN WITHIN DIMENSIONS				THIRD ANGLE PROJECTION		DRAWING		SERIES		DOCUMENT NUMBER	
DOCUMENT STATUS		P1		RELEASE DATE		2019/05/22		19:41:30		SD-45802-0001	
FORMAT: master-lb-prod-B		REVISION: 14		DATE: 2018/01/18		B-SIZE		45802		PSD 001 J1	
SEE TABLE		GENERAL MARKET		SHEET NUMBER		3 OF 4					

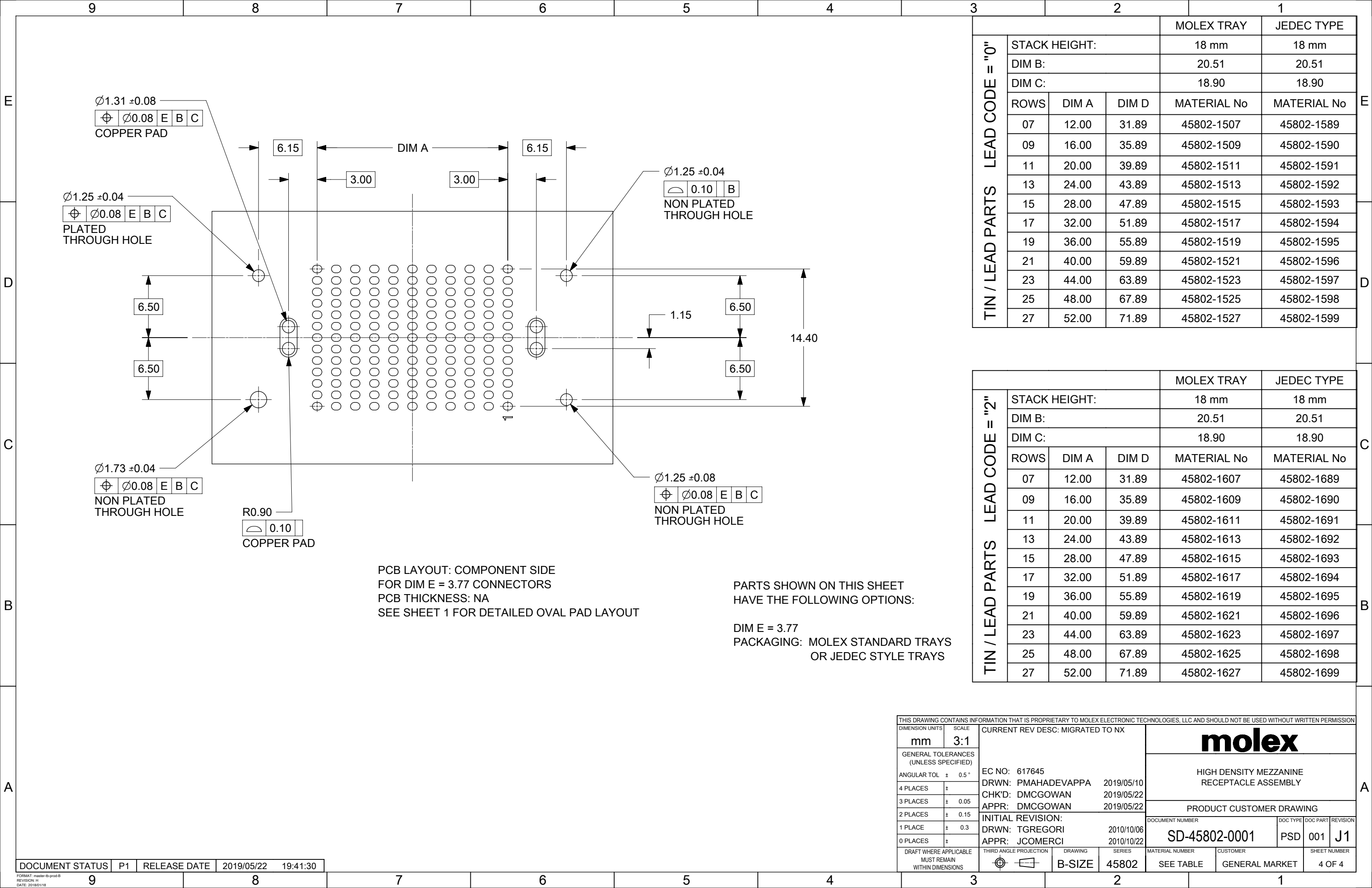

PCB LAYOUT: COMPONENT SIDE  
 FOR DIM E = 3.77 CONNECTORS  
 PCB THICKNESS: NA  
 SEE SHEET 1 FOR DETAILED OVAL PAD LAYOUT

PARTS SHOWN ON THIS SHEET  
 HAVE THE FOLLOWING OPTIONS:  
 DIM E = 3.77  
 PACKAGING: MOLEX STANDARD TRAYS  
 OR JEDEC STYLE TRAYS

			MOLEX TRAY	JEDEC TYPE
TIN / LEAD PARTS	LEAD CODE = "0"			
	STACK HEIGHT:		18 mm	18 mm
	DIM B:		20.51	20.51
	DIM C:		18.90	18.90
	ROWS	DIM A	DIM D	MATERIAL No
	07	12.00	31.89	45802-1507
	09	16.00	35.89	45802-1509
	11	20.00	39.89	45802-1511
	13	24.00	43.89	45802-1513
	15	28.00	47.89	45802-1515
17	32.00	51.89	45802-1517	
19	36.00	55.89	45802-1519	
21	40.00	59.89	45802-1521	
23	44.00	63.89	45802-1523	
25	48.00	67.89	45802-1525	
27	52.00	71.89	45802-1527	

			MOLEX TRAY	JEDEC TYPE
TIN / LEAD PARTS	LEAD CODE = "2"			
	STACK HEIGHT:		18 mm	18 mm
	DIM B:		20.51	20.51
	DIM C:		18.90	18.90
	ROWS	DIM A	DIM D	MATERIAL No
	07	12.00	31.89	45802-1607
	09	16.00	35.89	45802-1609
	11	20.00	39.89	45802-1611
	13	24.00	43.89	45802-1613
	15	28.00	47.89	45802-1615
17	32.00	51.89	45802-1617	
19	36.00	55.89	45802-1619	
21	40.00	59.89	45802-1621	
23	44.00	63.89	45802-1623	
25	48.00	67.89	45802-1625	
27	52.00	71.89	45802-1627	

THIS DRAWING CONTAINS INFORMATION THAT IS PROPRIETARY TO MOLEX ELECTRONIC TECHNOLOGIES, LLC AND SHOULD NOT BE USED WITHOUT WRITTEN PERMISSION

DIMENSION UNITS	SCALE	CURRENT REV DESC: MIGRATED TO NX		<b>molex</b>			
mm	3:1						
GENERAL TOLERANCES (UNLESS SPECIFIED)				HIGH DENSITY MEZZANINE RECEPTACLE ASSEMBLY			
ANGULAR TOL	± 0.5°	EC NO: 617645					
4 PLACES	±	DRWN: PMAHADEVAPPA 2019/05/10					
3 PLACES	± 0.05	CHK'D: DMCGOWAN 2019/05/22					
2 PLACES	± 0.15	APPR: DMCGOWAN 2019/05/22					
1 PLACE	± 0.3	INITIAL REVISION:					
0 PLACES	±	DRWN: TGREGORI 2010/10/06		PRODUCT CUSTOMER DRAWING			
		APPR: JCOMERCI 2010/10/22					
DRAFT WHERE APPLICABLE MUST REMAIN WITHIN DIMENSIONS		THIRD ANGLE PROJECTION	DRAWING	SERIES	MATERIAL NUMBER	CUSTOMER	SHEET NUMBER
			B-SIZE	45802	SEE TABLE	GENERAL MARKET	4 OF 4

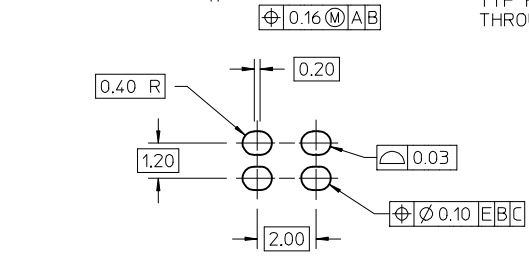
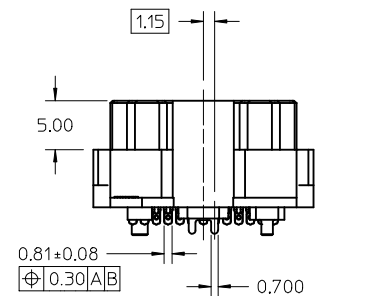
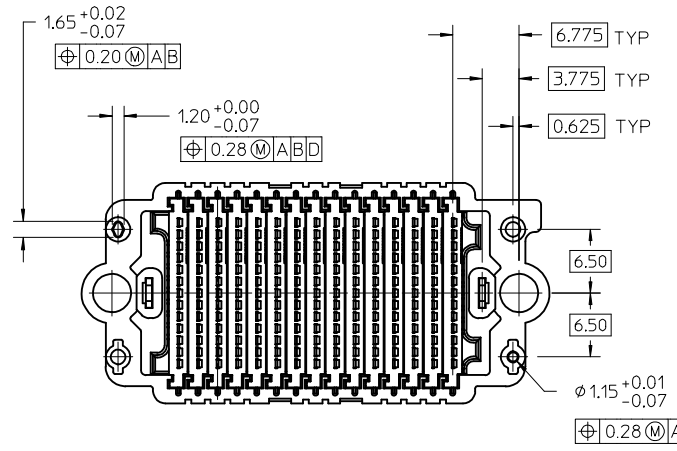
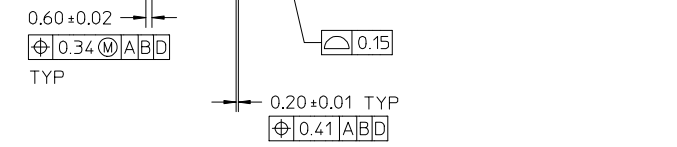
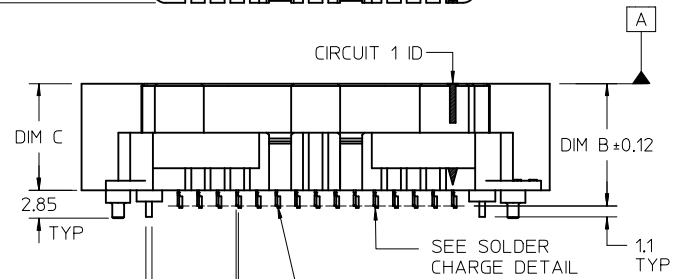
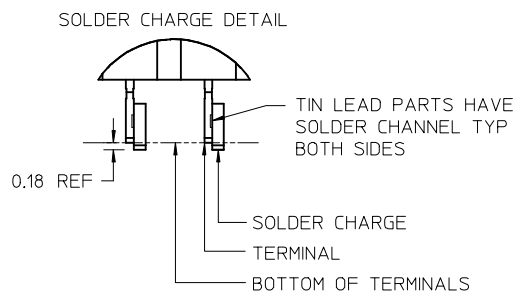
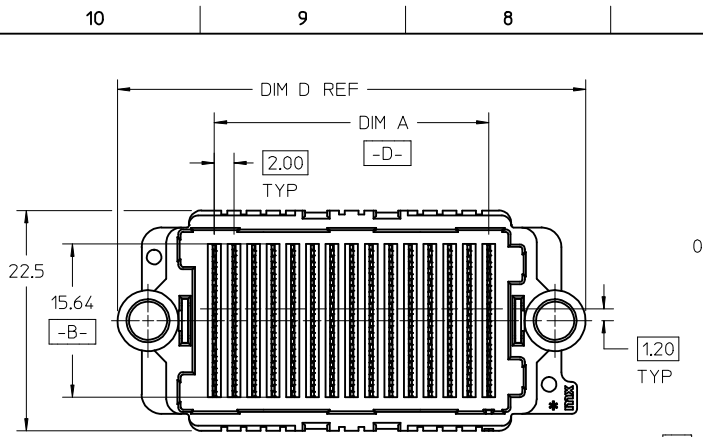

SOLDER PAD DETAIL  
TYP ALL PADS

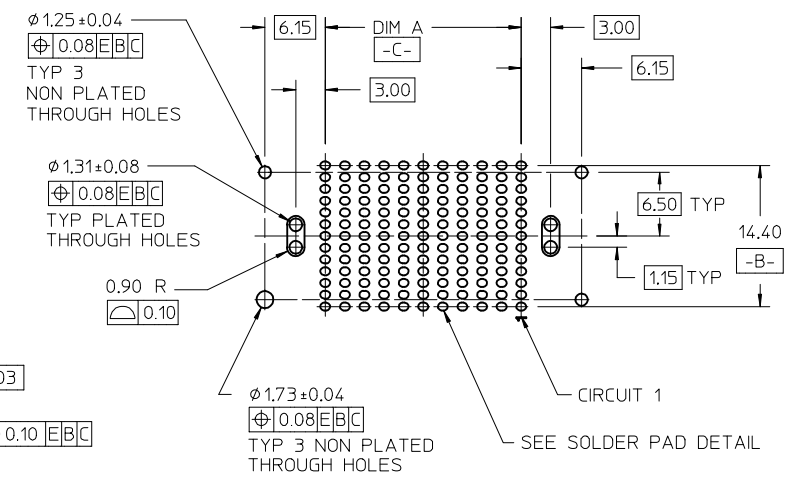

PCB LAYOUT: COMPONENT SIDE  
PCB THICKNESS: N/A

- NOTES:
- HOUSING MATERIAL: LCP, GLASS FILLED, UL 94V-0, BLACK  
CONTACT MATERIAL: HIGH PERFORMANCE ALLOY  
SOLDER NAIL MATERIAL: STAINLESS STEEL  
SOLDER CHARGE: SEE TABLE
  - FINISH: SELECT GOLD: 30 MICRO-INCHES MINIMUM IN CONTACT AREA  
SELECT TIN: 100 MICRO-INCHES MINIMUM IN TAIL AREA  
BOTH OVER NICKEL
  - PRODUCT SPECIFICATION: PS-45802-001
  - COSMETIC SPECIFICATION: PS-45499-002 CLASS B
  - PACKAGING SPECIFICATION: PK-45802-001 MOLEX STANDARD TRAYS  
PK-45802-0002 JEDEC STYLE TRAYS
  - DATUM -D- IS THE CENTERLINE OF THE 2 END SLOTS. END  
SLOT CENTERLINES ARE ESTABLISHED USING 2 MEASUREMENTS  
FOR EACH SLOT TAKEN 7.20 EITHER SIDE OF DATUM -B-
  - THERE ARE 13 CIRCUITS PER ROW.

<b>CLARIFY PEG LOCATION</b> EC NO: UCP2016-3732 DRWN: SVANG01 2016/03/24 CHKD: MCAN 2016/03/24 APPR: DMCGOWAN 2016/03/31	<b>QUALITY SYMBOLS</b> ▽=0 ▽=0 ▽=0	<b>GENERAL TOLERANCES (UNLESS SPECIFIED)</b>		<b>DIMENSION STYLE</b> MM ONLY	<b>SCALE</b> 2:1	<b>DESIGN UNITS</b> METRIC	THIRD ANGLE PROJECTION	
		mm	INCH	DRAWN BY TGREGORI	DATE 2010/10/06	<b>TITLE</b> HIGH DENSITY MEZZANINE RECEPTACLE ASSEMBLY WITH SHORT SOLDER NAILS		
		4 PLACES ± ---	± ---	CHECKED BY JCOMERCI	DATE 2010/10/22	<b>molex</b>		
		3 PLACES ± 0.05	± ---	APPROVED BY JCOMERCI		DATE 2010/10/22	DOCUMENT NO. SD-45802-0002	SHEET NO. 1 OF 3
2 PLACES ± 0.15	± ---	MATERIAL NO. SEE TABLE		THIS DRAWING CONTAINS INFORMATION THAT IS PROPRIETARY TO MOLEX INCORPORATED AND SHOULD NOT BE USED WITHOUT WRITTEN PERMISSION				
1 PLACE ± 0.30	± ---	ANGULAR ± 1/2° DRAFT WHERE APPLICABLE MUST REMAIN WITHIN DIMENSIONS		SIZE B				
0 PLACE ±	±							

			10	9	8	7	6	5	4	3	2	1	
F TIN / LEAD PARTS LEAD CODE = "0"	STACK HEIGHT:		8 mm	9 mm	10 mm	11 mm	12 mm	13 mm	14 mm	15 mm	17 mm	18 mm	
	DIM B:		10.51	11.51	12.51	13.51	14.51	15.51	16.51	17.51	19.51	20.51	
	DIM C:		8.90	9.90	10.90	11.90	12.90	13.90	14.90	15.90	17.90	18.90	
	ROWS	DIM A	DIM G	MATERIAL No	MATERIAL No	MATERIAL No	MATERIAL No	MATERIAL No	MATERIAL No	MATERIAL No	MATERIAL No	MATERIAL No	MATERIAL No
	07	12.00	31.89	45802-0707	45802-3707	45802-2707	45802-8707	45802-4707	45802-9707	45802-6707	45802-7707	45802-5707	45802-1707
	09	16.00	35.89	45802-0709	45802-3709	45802-2709	45802-8709	45802-4709	45802-9709	45802-6709	45802-7709	45802-5709	45802-1709
	11	20.00	39.89	45802-0711	45802-3711	45802-2711	45802-8711	45802-4711	45802-9711	45802-6711	45802-7711	45802-5711	45802-1711
	13	24.00	43.89	45802-0713	45802-3713	45802-2713	45802-8713	45802-4713	45802-9713	45802-6713	45802-7713	45802-5713	45802-1713
	15	28.00	47.89	45802-0715	45802-3715	45802-2715	45802-8715	45802-4715	45802-9715	45802-6715	45802-7715	45802-5715	45802-1715
	17	32.00	51.89	45802-0717	45802-3717	45802-2717	45802-8717	45802-4717	45802-9717	45802-6717	45802-7717	45802-5717	45802-1717
	19	36.00	55.89	45802-0719	45802-3719	45802-2719	45802-8719	45802-4719	45802-9719	45802-6719	45802-7719	45802-5719	45802-1719
	21	40.00	59.89	45802-0721	45802-3721	45802-2721	45802-8721	45802-4721	45802-9721	45802-6721	45802-7721	45802-5721	45802-1721
23	44.00	63.89	45802-0723	45802-3723	45802-2723	45802-8723	45802-4723	45802-9723	45802-6723	45802-7723	45802-5723	45802-1723	
25	48.00	67.89	45802-0725	45802-3725	45802-2725	45802-8725	45802-4725	45802-9725	45802-6725	45802-7725	45802-5725	45802-1725	
27	52.00	71.89	45802-0727	45802-3727	45802-2727	45802-8727	45802-4727	45802-9727	45802-6727	45802-7727	45802-5727	45802-1727	

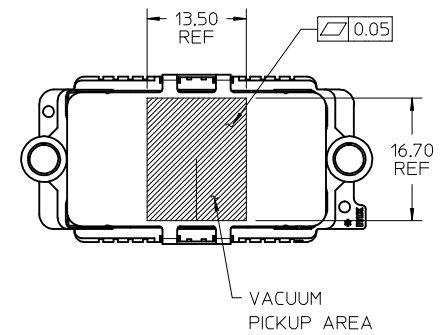

			10	9	8	7	6	5	4	3	2	1	
D C TIN PARTS LEAD CODE = "2"	STACK HEIGHT:		8 mm	9 mm	10 mm	11 mm	12 mm	13 mm	14 mm	15 mm	17 mm	18 mm	
	DIM B:		10.51	11.51	12.51	13.51	14.51	15.51	16.51	17.51	19.51	20.51	
	DIM C:		8.90	9.90	10.90	11.90	12.90	13.90	14.90	15.90	17.90	18.90	
	ROWS	DIM A	DIM G	MATERIAL No	MATERIAL No	MATERIAL No	MATERIAL No	MATERIAL No	MATERIAL No	MATERIAL No	MATERIAL No	MATERIAL No	MATERIAL No
	07	12.00	31.89	45802-0807	45802-3807	45802-2807	45802-8807	45802-4807	45802-9807	45802-6807	45802-7807	45802-5807	45802-1807
	09	16.00	35.89	45802-0809	45802-3809	45802-2809	45802-8809	45802-4809	45802-9809	45802-6809	45802-7809	45802-5809	45802-1809
	11	20.00	39.89	45802-0811	45802-3811	45802-2811	45802-8811	45802-4811	45802-9811	45802-6811	45802-7811	45802-5811	45802-1811
	13	24.00	43.89	45802-0813	45802-3813	45802-2813	45802-8813	45802-4813	45802-9813	45802-6813	45802-7813	45802-5813	45802-1813
	15	28.00	47.89	45802-0815	45802-3815	45802-2815	45802-8815	45802-4815	45802-9815	45802-6815	45802-7815	45802-5815	45802-1815
	17	32.00	51.89	45802-0817	45802-3817	45802-2817	45802-8817	45802-4817	45802-9817	45802-6817	45802-7817	45802-5817	45802-1817
	19	36.00	55.89	45802-0819	45802-3819	45802-2819	45802-8819	45802-4819	45802-9819	45802-6819	45802-7819	45802-5819	45802-1819
	21	40.00	59.89	45802-0821	45802-3821	45802-2821	45802-8821	45802-4821	45802-9821	45802-6821	45802-7821	45802-5821	45802-1821
23	44.00	63.89	45802-0823	45802-3823	45802-2823	45802-8823	45802-4823	45802-9823	45802-6823	45802-7823	45802-5823	45802-1823	
25	48.00	67.89	45802-0825	45802-3825	45802-2825	45802-8825	45802-4825	45802-9825	45802-6825	45802-7825	45802-5825	45802-1825	
27	52.00	71.89	45802-0827	45802-3827	45802-2827	45802-8827	45802-4827	45802-9827	45802-6827	45802-7827	45802-5827	45802-1827	

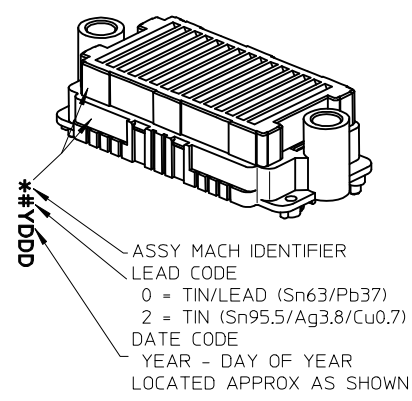

ALL PARTS ON THIS SHEET  
HAVE THE FOLLOWING OPTIONS

PACKAGING: MOLEX STANDARD TRAY

NOTE:  
1. SOLDER CHARGE COMPOSITION  
TIN/LEAD: Sn 63/Pb 37  
TIN: Sn 95.5/ Ag 3.8/ Cu 0.7

SEE SHEET 1 EC NO: UCP2016-3732 DRWNS:SVANG01 2016/03/24 CHKD:KACAIN 2016/03/24 APPR:DMCGOWAN 2016/03/31	QUALITY SYMBOLS	GENERAL TOLERANCES (UNLESS SPECIFIED)	DIMENSION STYLE	SCALE	DESIGN UNITS	THIRD ANGLE PROJECTION
	$\nabla F=0$ $\nabla E=0$ $\nabla D=0$	mm INCH	MM ONLY	1.5:1	METRIC	
		4 PLACES ± --- ± ---	DRAWN BY DATE	TREGORI 2010/10/06	TITLE	HIGH DENSITY MEZZANINE RECEPTACLE ASSEMBLY WITH SHORT SOLDER NAILS
		3 PLACES ± 0.05 ± ---	CHECKED BY DATE			
	2 PLACES ± 0.15 ± ---	APPROVED BY DATE	JCOMERCI 2010/10/22			
	1 PLACE ± 0.30 ± ---	MATERIAL NO.		DOCUMENT NO.	SD-45802-0002	
	0 PLACE ± ±	ANGULAR ± 1/2°	SEE TABLE	SHEET NO.	2 OF 3	
		DRAFT WHERE APPLICABLE MUST REMAIN WITHIN DIMENSIONS	SIZE B	THIS DRAWING CONTAINS INFORMATION THAT IS PROPRIETARY TO MOLEX INCORPORATED AND SHOULD NOT BE USED WITHOUT WRITTEN PERMISSION		

			10	9	8	7	6	5	4	3	2	1	
F TIN / LEAD PARTS	STACK HEIGHT:		8 mm	9 mm	10 mm	11 mm	12 mm	13 mm	14 mm	15 mm	17 mm	18 mm	
	DIM B:		10.51	11.51	12.51	13.51	14.51	15.51	16.51	17.51	19.51	20.51	
	DIM C:		8.90	9.90	10.90	11.90	12.90	13.90	14.90	15.90	17.90	18.90	
	ROWS	DIM A	DIM G	MATERIAL No	MATERIAL No	MATERIAL No	MATERIAL No	MATERIAL No	MATERIAL No	MATERIAL No	MATERIAL No	MATERIAL No	
	07	12.00	31.89	45802-0789	45802-3789	45802-2789	45802-8789	45802-4789	45802-9789	45802-6789	45802-7789	45802-5789	45802-1789
	09	16.00	35.89	45802-0790	45802-3790	45802-2790	45802-8790	45802-4790	45802-9790	45802-6790	45802-7790	45802-5790	45802-1790
	11	20.00	39.89	45802-0791	45802-3791	45802-2791	45802-8791	45802-4791	45802-9791	45802-6791	45802-7791	45802-5791	45802-1791
	13	24.00	43.89	45802-0792	45802-3792	45802-2792	45802-8792	45802-4792	45802-9792	45802-6792	45802-7792	45802-5792	45802-1792
	15	28.00	47.89	45802-0793	45802-3793	45802-2793	45802-8793	45802-4793	45802-9793	45802-6793	45802-7793	45802-5793	45802-1793
	17	32.00	51.89	45802-0794	45802-3794	45802-2794	45802-8794	45802-4794	45802-9794	45802-6794	45802-7794	45802-5794	45802-1794
	19	36.00	55.89	45802-0795	45802-3795	45802-2795	45802-8795	45802-4795	45802-9795	45802-6795	45802-7795	45802-5795	45802-1795
	21	40.00	59.89	45802-0796	45802-3796	45802-2796	45802-8796	45802-4796	45802-9796	45802-6796	45802-7796	45802-5796	45802-1796
	23	44.00	63.89	45802-0797	45802-3797	45802-2797	45802-8797	45802-4797	45802-9797	45802-6797	45802-7797	45802-5797	45802-1797
25	48.00	67.89	45802-0798	45802-3798	45802-2798	45802-8798	45802-4798	45802-9798	45802-6798	45802-7798	45802-5798	45802-1798	
27	52.00	71.89	45802-0799	45802-3799	45802-2799	45802-8799	45802-4799	45802-9799	45802-6799	45802-7799	45802-5799	45802-1799	

			10	9	8	7	6	5	4	3	2	1	
D C TIN PARTS	STACK HEIGHT:		8 mm	9 mm	10 mm	11 mm	12 mm	13 mm	14 mm	15 mm	17 mm	18 mm	
	DIM B:		10.51	11.51	12.51	13.51	14.51	15.51	16.51	17.51	19.51	20.51	
	DIM C:		8.90	9.90	10.90	11.90	12.90	13.90	14.90	15.90	17.90	18.90	
	ROWS	DIM A	DIM G	MATERIAL No	MATERIAL No	MATERIAL No	MATERIAL No	MATERIAL No	MATERIAL No	MATERIAL No	MATERIAL No	MATERIAL No	
	07	12.00	31.89	45802-0889	45802-3889	45802-2889	45802-8889	45802-4889	45802-9889	45802-6889	45802-7889	45802-5889	45802-1889
	09	16.00	35.89	45802-0890	45802-3890	45802-2890	45802-8890	45802-4890	45802-9890	45802-6890	45802-7890	45802-5890	45802-1890
	11	20.00	39.89	45802-0891	45802-3891	45802-2891	45802-8891	45802-4891	45802-9891	45802-6891	45802-7891	45802-5891	45802-1891
	13	24.00	43.89	45802-0892	45802-3892	45802-2892	45802-8892	45802-4892	45802-9892	45802-6892	45802-7892	45802-5892	45802-1892
	15	28.00	47.89	45802-0893	45802-3893	45802-2893	45802-8893	45802-4893	45802-9893	45802-6893	45802-7893	45802-5893	45802-1893
	17	32.00	51.89	45802-0894	45802-3894	45802-2894	45802-8894	45802-4894	45802-9894	45802-6894	45802-7894	45802-5894	45802-1894
	19	36.00	55.89	45802-0895	45802-3895	45802-2895	45802-8895	45802-4895	45802-9895	45802-6895	45802-7895	45802-5895	45802-1895
	21	40.00	59.89	45802-0896	45802-3896	45802-2896	45802-8896	45802-4896	45802-9896	45802-6896	45802-7896	45802-5896	45802-1896
	23	44.00	63.89	45802-0897	45802-3897	45802-2897	45802-8897	45802-4897	45802-9897	45802-6897	45802-7897	45802-5897	45802-1897
25	48.00	67.89	45802-0898	45802-3898	45802-2898	45802-8898	45802-4898	45802-9898	45802-6898	45802-7898	45802-5898	45802-1898	
27	52.00	71.89	45802-0899	45802-3899	45802-2899	45802-8899	45802-4899	45802-9899	45802-6899	45802-7899	45802-5899	45802-1899	

ALL PARTS ON THIS SHEET HAVE THE FOLLOWING OPTIONS:  
PACKAGING: JEDEC STYLE TRAY

A SEE SHEET 1 EC NO: UCP2016-3732 DRAWN: SVANG01 2016/03/24 CHKD: MCAIN 2016/03/24 APPR: DMC GOWAN 2016/03/31	F REV	QUALITY SYMBOLS	GENERAL TOLERANCES (UNLESS SPECIFIED)	DIMENSION STYLE	SCALE	DESIGN UNITS	THIRD ANGLE PROJECTION	
		▽F=0	mm INCH	MM ONLY	1:1	METRIC	⊙	
		▽E=0	4 PLACES ± --- ± ---	DRAWN BY DATE	TITILE	HIGH DENSITY MEZZANINE RECEPTACLE ASSEMBLY WITH SHORT SOLDER NAILS		
		▽F=0	3 PLACES ± 0.05 ± ---	TGREGORI 2010/10/06	SD-45802-0002	molex		
		2 PLACES ± 0.15 ± ---	1 PLACE ± 0.30 ± ---	CHECKED BY DATE	APPROVED BY DATE	DOCUMENT NO.	SHEET NO.	
		0 PLACE ± ±		JCOMERCI 2010/10/22		SD-45802-0002	3 OF 3	
		ANGULAR ± 1/2° DRAFT WHERE APPLICABLE MUST REMAIN WITHIN DIMENSIONS		MATERIAL NO.	THIS DRAWING CONTAINS INFORMATION THAT IS PROPRIETARY TO MOLEX INCORPORATED AND SHOULD NOT BE USED WITHOUT WRITTEN PERMISSION			
				SEE TABLE				