

LOADING PATTERN MATING SIDE

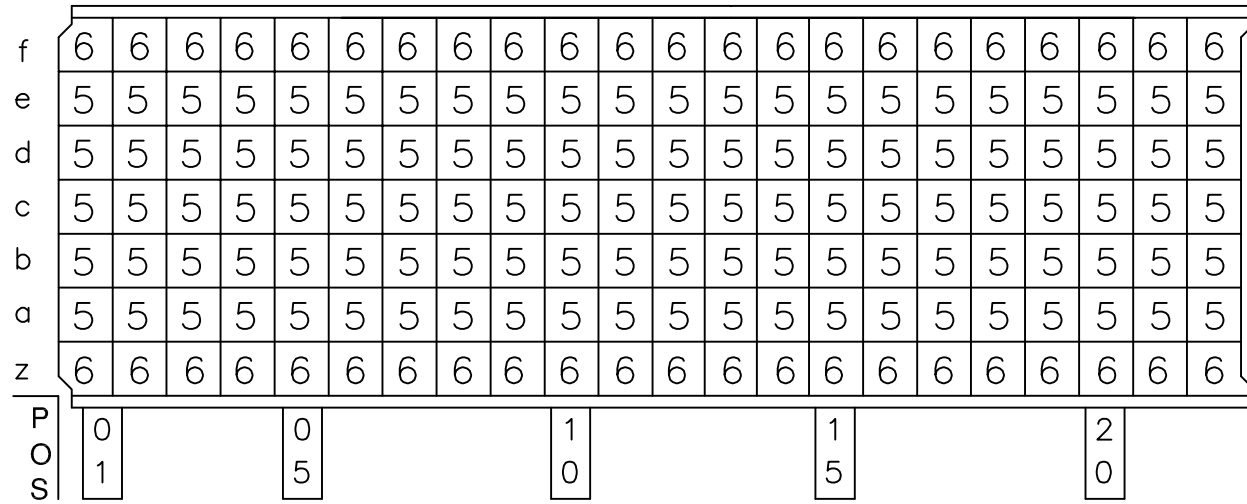

LOADED CONNECTOR ASSEMBLY (FOR EXAMPLE)

LOADED CONNECTOR ASSEMBLY (FOR EXAMPLE)

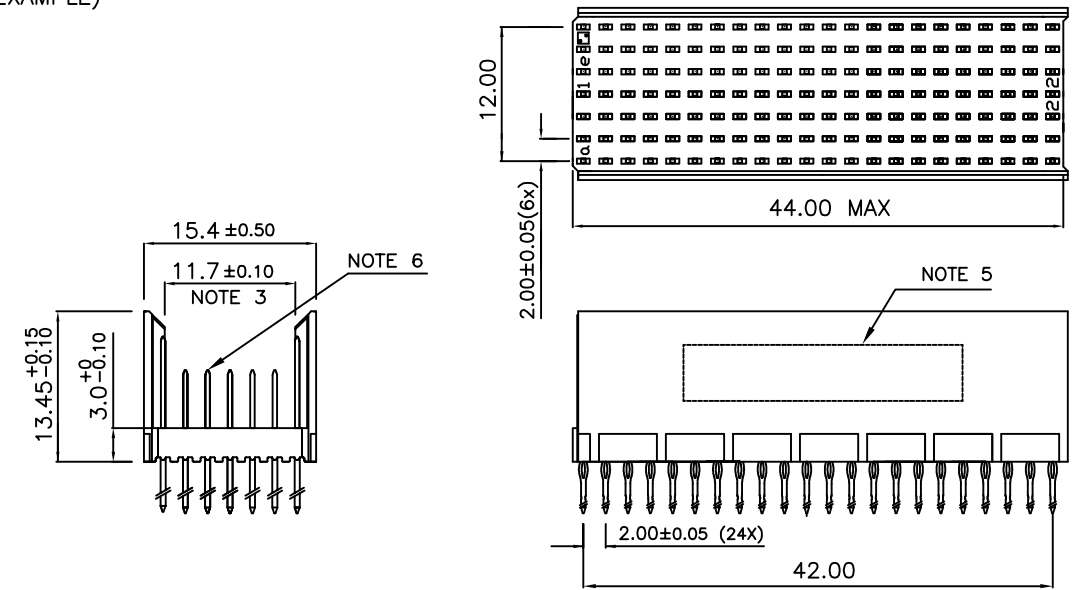

CONTACT OVERVIEW

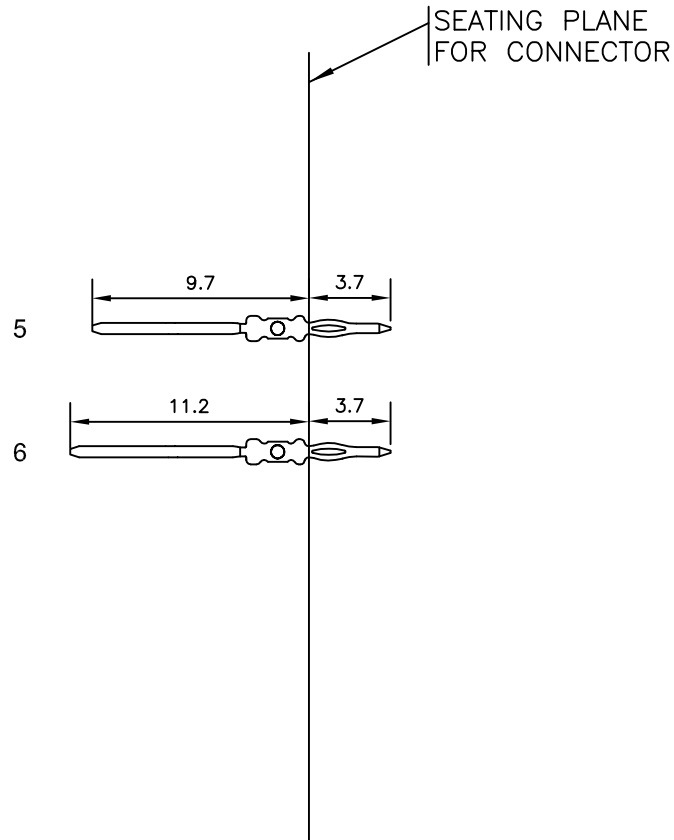

LEAD FREE INDICATOR : LF = LEAD FREE (DIGIT 15 & 16)

PLATING CODE (DIGIT 13 AND 14)

HM2P70PAE121

PLATING TABLE

CODE	PLATING	CONTACT AREA	TYPE OF TERMINAL	PERFORMANCE LEVEL
AA	0.75µ Au	GOLD OVER NICKEL PLATING.	SHORT TERMINAL EON PRESSFIT CONTACTS	IEC PERFORMANCE LEVEL 2 (250 mating cycles) or TELCORDIA CO
AB	1.25µ Au	GOLD OVER NICKEL PLATING.	SHORT TERMINAL EON PRESSFIT CONTACTS	TELCORDIA UE

LAY-OUT P.C.B.-HOLE

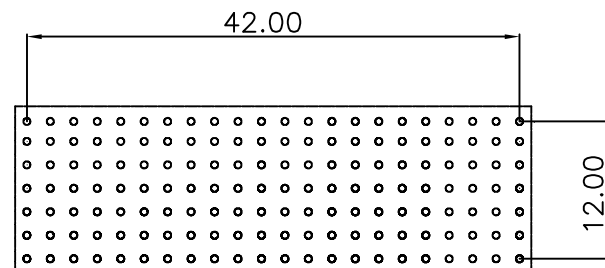

NOTES

- THIS PRODUCT IS CSA APPROVED.
- THIS PRODUCT IS UL RECOGNIZED.
- MEASURED AT THE BOTTOM.
- FOR GENERAL DETAILS PLEASE REFER DRAWING: BS, C ,203028, 000
- CONNECTOR PRINTED WITH P/N AND DATE CODE.
- FOR ACTUAL CONTACT LOADINGS, SEE LOADING PATTERN MATING SIDE.
- THIS PRODUCT MEETS EUROPEAN UNION DIRECTIVES AND OTHER COUNTRY REGULATIONS AS DESCRIBED IN GS-47-0004
- FOR RECOMMENDED PTH DIMENSIONS REFER DRAWING : BS, A , 201572 , 001

CATALOG NO: HM2P70PAE121--LF

mat'l. code		surface		tolerance		projection		product family	
SEE NOTE 4		ISO 1302		ISO 406 ISO 1101				MILLIPACS	
ltr		ecn no		dr		date		title	
A		109-0210		MINI		2009-10-06		MPACS 5+2R STR HDR PF CONN TYPE B 22 POS.	
B		109-0290		AB		2009-12-29			
C		110-0018		MINI		2010-01-13			
D		ELX-1-32701		BIN		2019-02-18			
				dr		MINI K VANDANATH 2009-10-06		dwg no	
				enr		BINESH C 2019-02-18		sheet 1 of 1	
				chr		ALEX BABU 2019-02-18		size	
				appd		ALEX BABU 2019-02-18		A3	
sheet index		revision		C.1				type	
1		sheet		1				Product Customer Drawing	