



**austriamicrosystems AG**

**is now**

**ams AG**

The technical content of this austriamicrosystems datasheet is still valid.

**Contact information:**

**Headquarters:**

ams AG

Tobelbaderstrasse 30

8141 Unterpremstaetten, Austria

Tel: +43 (0) 3136 500 0

e-Mail: [ams\\_sales@ams.com](mailto:ams_sales@ams.com)

Please visit our website at [www.ams.com](http://www.ams.com)

# AS1920, AS1922

## Triple-Voltage, Micro-Power Microprocessor Supervisory Circuits

### 1 General Description

The AS1920 and AS1922 microprocessor supervisory circuits were designed to generate a reset when at least one of the three monitored supply voltages falls below its respective trip threshold.

These very-low-current (6.2µA, typ) devices maintain reset for a minimum timeout period after all supplies have stabilized. Guaranteed to be in the correct state for  $V_{CC} > +1.0V$ , these devices are perfect for multiple-voltage systems with low current requirements and strict monitoring requirements.

The devices are available as the standard products listed in Table 1.

Table 1. Standard Products

Model	Output Type	Supervisory Voltages
AS1920-18	Push/Pull	3V, 1.8V, Adjustable
AS1922-18	Open-Drain	3V, 1.8V, Adjustable

All devices monitor primary and secondary factory-trimmed voltages. Additionally, a third monitoring voltage can be selected via an external resistor divider.

The AS1920 has an active-low push/pull reset output, whereas the AS1922 has an active-low open-drain reset output.

The AS1920 and AS1922 are available in a 5-pin SOT23 package.

### 2 Key Features

- Simultaneous Triple-Voltage Monitoring
- Very-Low Supply Current: 6.2µA
- ±1.5% Accuracy Over Temperature
- Reset Time Delay: 200ms
- Power Supply Transient Immunity
- Guaranteed Reset for  $V_{CC3} \geq 1V$  or  $V_{CC18} \geq 1V$
- Active-Low Push/Pull Reset Output (AS1920)
- Active-Low Open-Drain Reset Output (AS1922)
- 5-pin SOT23 Package

### 3 Applications

The devices are ideal for personal computers, notebooks, battery-powered systems, embedded controllers, intelligent instruments, automotive systems, critical CPU monitoring, and any multi-supply monitoring application.

Figure 1. Typical Application Diagram

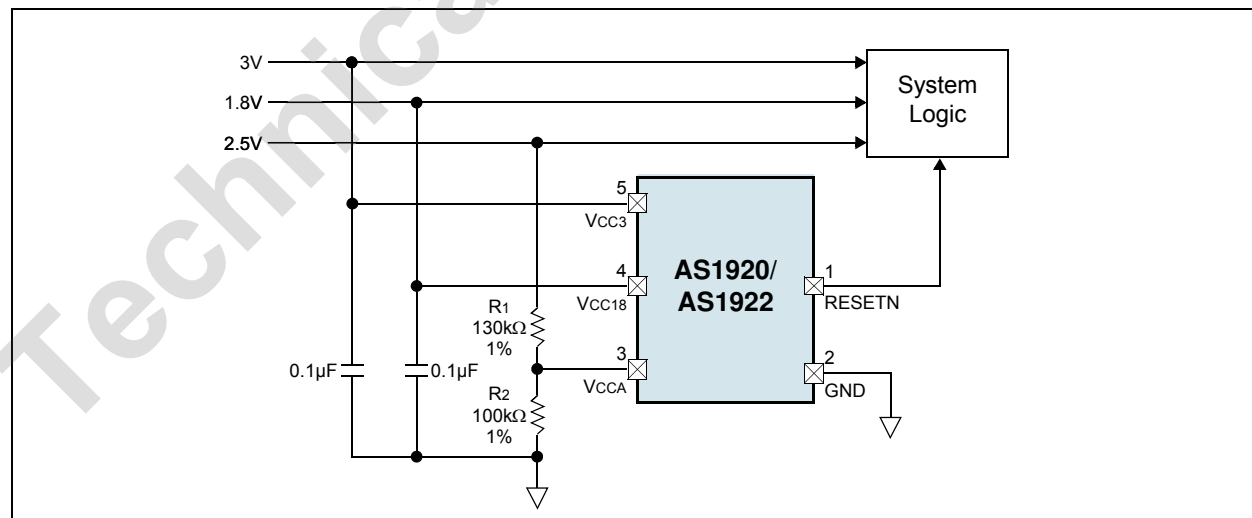

## 4 Pinout

### Pin Assignments

Figure 2. Pin Assignments (Top View)

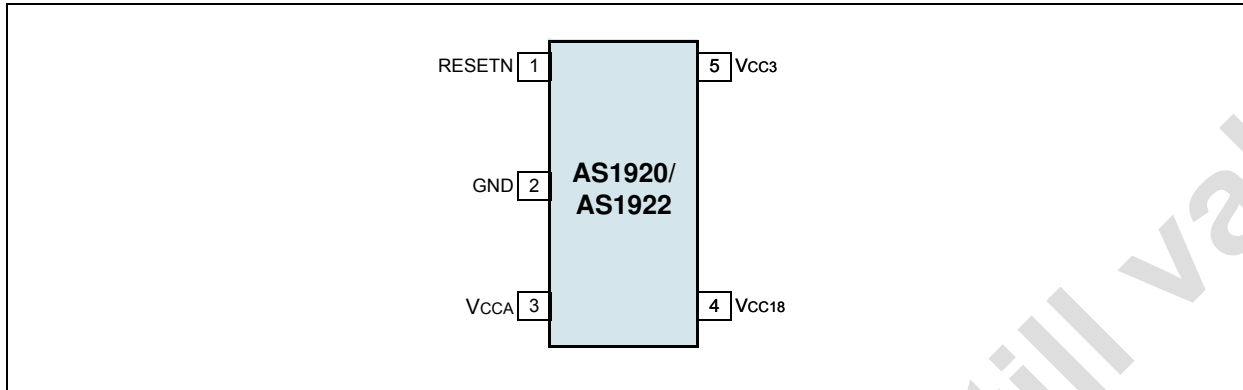

### Pin Descriptions

Table 2. Pin Descriptions

Pin Number	Pin Name	Description
1	RESETN	<b>Reset Logic Output.</b> This active-low pin serves as the 3V push/pull reset output. A reset is asserted when any one of the supplies are below its respective trip threshold and the reset is held for 200ms after all power supplies have stabilized.
2	GND	<b>Ground.</b>
3	VCCA	<b>VCCA.</b> 1V sense, high-impedance input. <b>Note:</b> If this pin is not used it should be tied to VCC3 or VCC18.
4	VCC18	<b>VCC18.</b> 1.8V sense input and power detect pin (AS1920-18, AS1922-18). This pin provides power to the output reset stage of the device in order to assert a valid reset when the voltage on the primary input is down. <b>Note:</b> Bypass this pin to GND with a $\geq 0.1\mu\text{F}$ ceramic capacitor.
5	VCC3	<b>VCC3.</b> 3V sense input and power supply pin (AS1920-18, AS1922-18). This pin provides power to the device. <b>Note:</b> Bypass this pin to GND with a $\geq 0.1\mu\text{F}$ ceramic capacitor.

## 5 Absolute Maximum Ratings

Stresses beyond those listed in [Table 3](#) may cause permanent damage to the device. These are stress ratings only, and functional operation of the device at these or any other conditions beyond those indicated in [Electrical Characteristics on page 4](#) is not implied. Exposure to absolute maximum rating conditions for extended periods may affect device reliability.

Table 3. Absolute Maximum Ratings

Parameter	Min	Max	Units	Comments
VCC18, VCC3, VCCA to GND	-0.3V	+5	V	
RESETN Open-Drain	-0.3	+7	V	
RESETN to GND	-0.3	VCC3 + 0.3	V	
Operating Temperature Range	-40	+85	°C	Guaranteed to meet specified performance from 0 to 70°C and is designed, characterized and assured to meet the extended temperature limits of -40 to 85°C but are not tested at these temperatures.
Storage Temperature Range	-65	+150	°C	
Package Body Temperature		+260	°C	The reflow peak soldering temperature (body temperature) specified is in accordance with IPC/JEDEC J-STD-020C "Moisture/Reflow Sensitivity Classification for Non-Hermetic Solid State Surface Mount Devices". The lead finish for Pb-free leaded packages is matte tin (100% Sn).

## 6 Electrical Characteristics

$V_{CC18} = 1.8V$ ,  $V_{CC3} = 3V$ ,  $V_{CCA} = V_{CC3}$ ,  $T_{AMB} = -40$  to  $+85^{\circ}C$  (unless otherwise specified).

Table 4. Electrical Characteristics

Symbol	Parameter	Conditions	Min	Typ	Max	Unit
VRT18	Reset Threshold VCC18		1.653	1.683	1.713	V
VRT3	Reset Threshold VCC3		2.763	2.805	2.847	V
VRTA	Reset Threshold VCCA		0.982	1.00	1.018	V
VCC3, VCC18	Operating Voltage	RESETN in Correct Logic State	1		3.3	V
IVCC18	VCC18 Supply Current	$V_{CC18} < V_{CC3}$ , $V_{CC18} = 1.8V$		0.7	2	$\mu A$
IVCC3	VCC3 Supply Current	$V_{CC18} < V_{CC3}$ , $V_{CC3} = 3V$		6.2	15	$\mu A$
IVCCA <sup>1</sup>	VCCA Input Current	$V_{CCA} = 1V$	-15	0	15	nA
IOUT	Open-Drain RESETN Output Current	Reset Not Asserted, Forced to 0V	2	4	13	$\mu A$
ILEAK	Open-Drain RESETN Output Leakage Current	Reset Not Asserted, RESETN Forced to 5.5V, $T_{AMB} = 25^{\circ}C$	-0.1		0.1	$\mu A$
tRST	Reset Pulse Width	RESETN Low, $T_{AMB} = 25^{\circ}C$ <sup>2</sup>	140	200	280	ms
tUV	VCC Undervoltage Detect to RESETN	$V_{CC18}$ , $V_{CC3}$ , or $V_{CCA} <$ Reset Threshold by $> 1\%$ <sup>2</sup> $T_{AMB} = 25^{\circ}C$		130		$\mu s$
VOL	Output Voltage Low, RESETN	$I_{SINK} = 2.5mA$ , $V_{CC3} = 3V$ , $V_{CC18} = 0V$		0.15	0.4	V
		$I_{SINK} = 100\mu A$ , $V_{CC3} = 1V$ , $V_{CC18} = 0V$		0.05	0.3	
		$I_{SINK} = 100\mu A$ , $V_{CC3} = 0V$ , $V_{CC18} = 1V$		0.05	0.3	
		$I_{SINK} = 100\mu A$ , $V_{CC3} = 1V$ , $V_{CC18} = 1V$		0.05	0.3	
VOH	Output Voltage High, RESETN	$I_{SOURCE} = 1\mu A$ (AS1922-xx)	$V_{CC3} - 1$	$V_{CC3} - 0.65$		V

1. Guaranteed by design.

2. Measured from the time ( $t_1$ ) when the input passes through the input threshold voltage ( $V_{RTX}$ ) to the time ( $t_2$ ) when RESETN passes through 1.5V.

## 7 Typical Operating Characteristics

$T_{AMB} = +25^{\circ}\text{C}$  (unless otherwise specified).

Figure 3.  $I_{VCC18}$  vs. Temperature

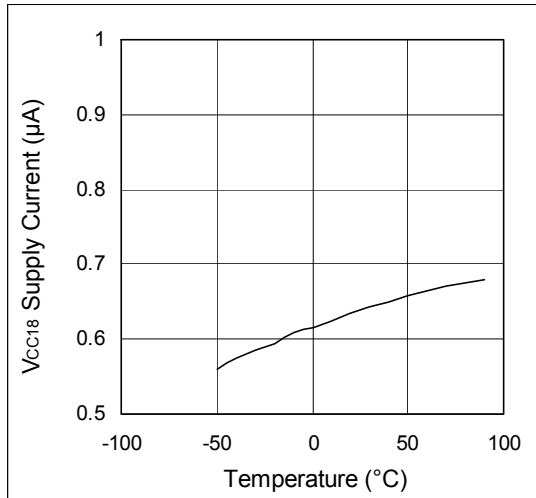

Figure 4.  $I_{VCC3}$  vs. Temperature;  $V_{CC3} = 3\text{V}$

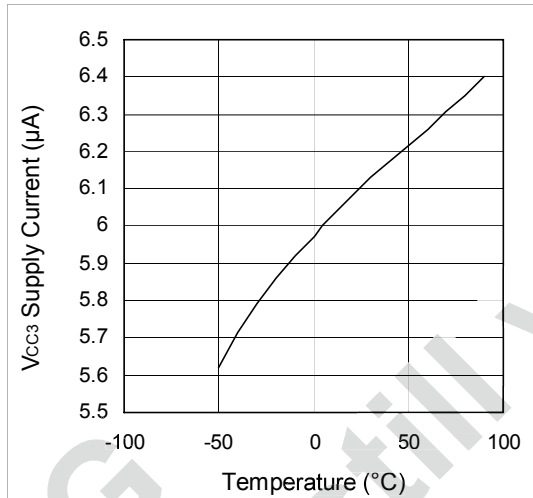

Figure 5. Supply Current  $V_{CCA}$  vs. Temperature

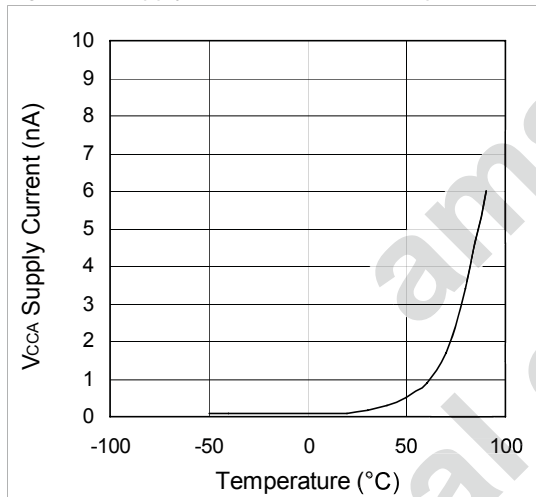

Figure 6.  $V_{OH/RST}$  vs. Temperature;  $V_{CC3} = 3\text{V}$

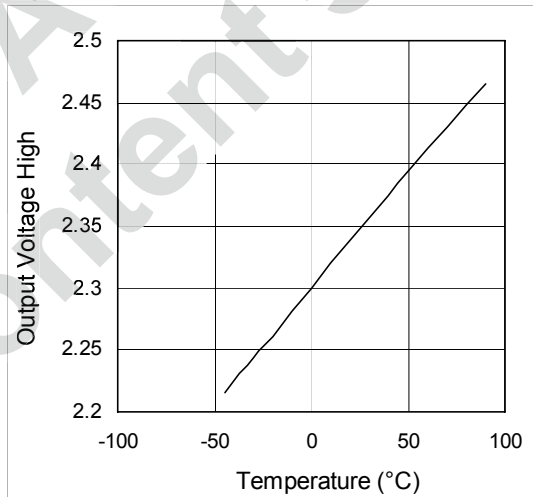

Figure 7.  $t_{RST}$  vs. Temperature;  $V_{CC3} = V_{CCA} = 3\text{V}$

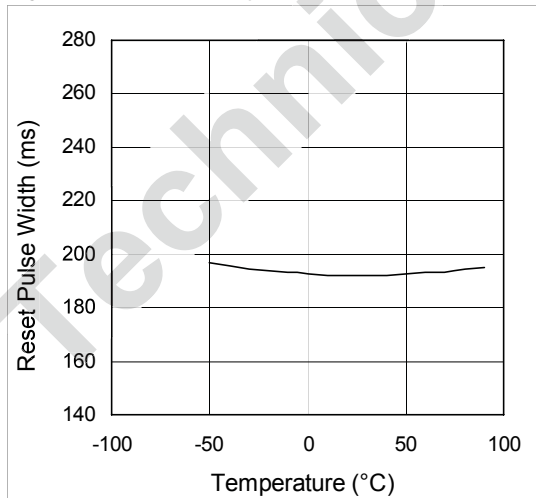
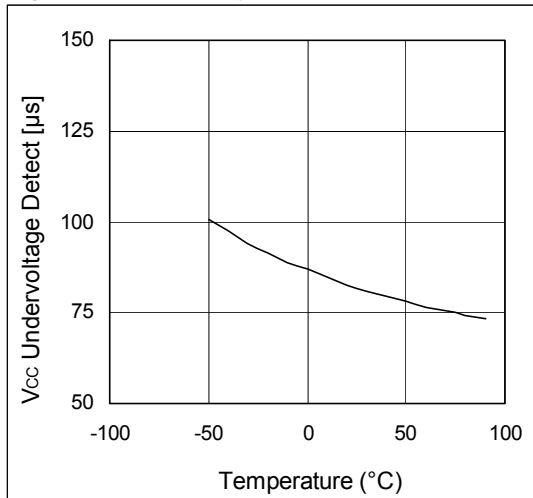

Figure 8.  $t_{UV}$  vs. Temperature;  $V_{CC3} = V_{CCA} = 3\text{V}$



## 8 Detailed Description

The AS1920/AS1922 microprocessor supervisory circuits were designed to generate a reset when at least one of the three monitored supply voltages falls below its respective trip threshold.

These very-low-current (6.5 $\mu$ A, typ) devices maintain reset for a minimum timeout period after all supplies have stabilized. Guaranteed to be in the correct state for  $V_{CC} > +1.0V$ , these devices are perfect for multiple-voltage systems with low current requirements and strict monitoring requirements.

Figure 9. AS1920 Block Diagram

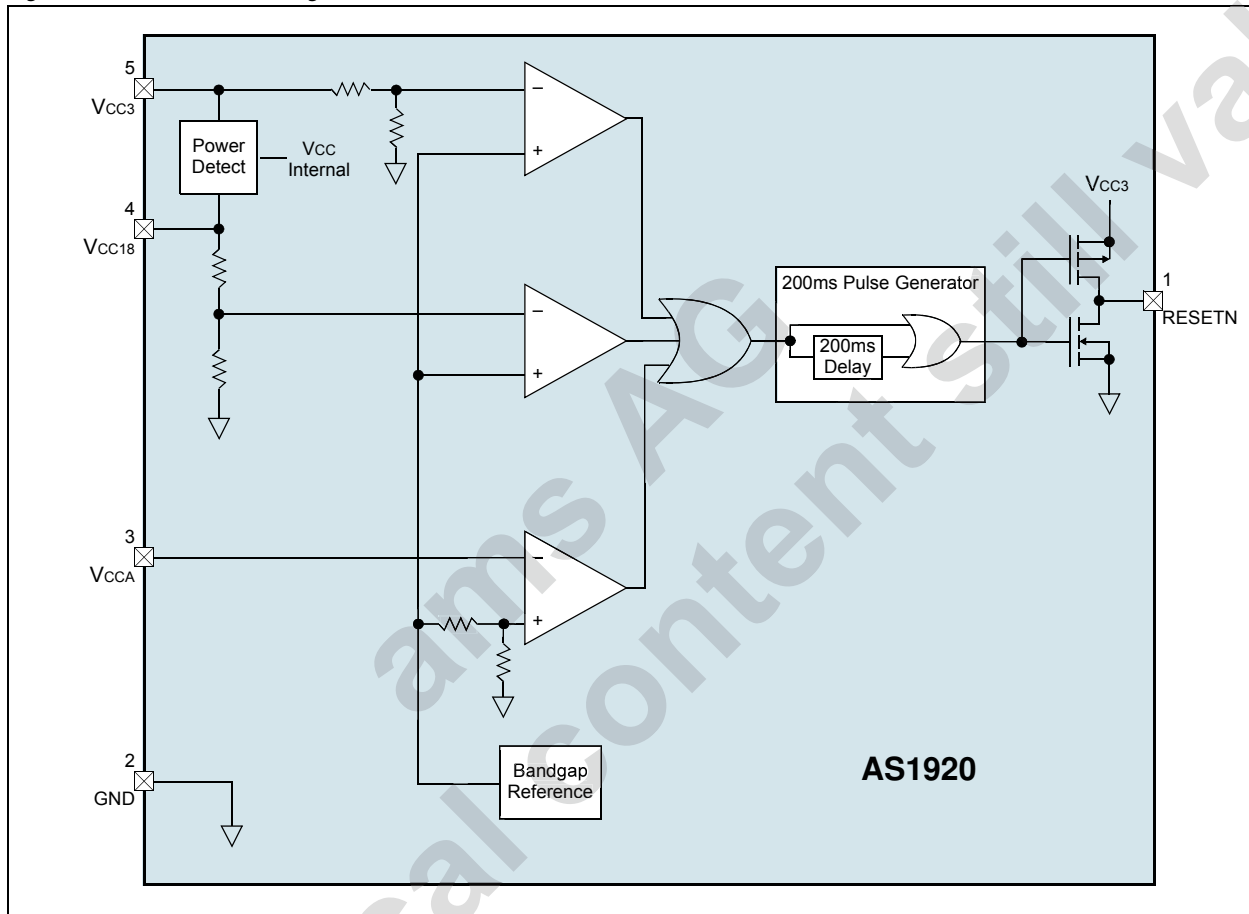

Figure 10. Vcc Monitor Timing Diagram

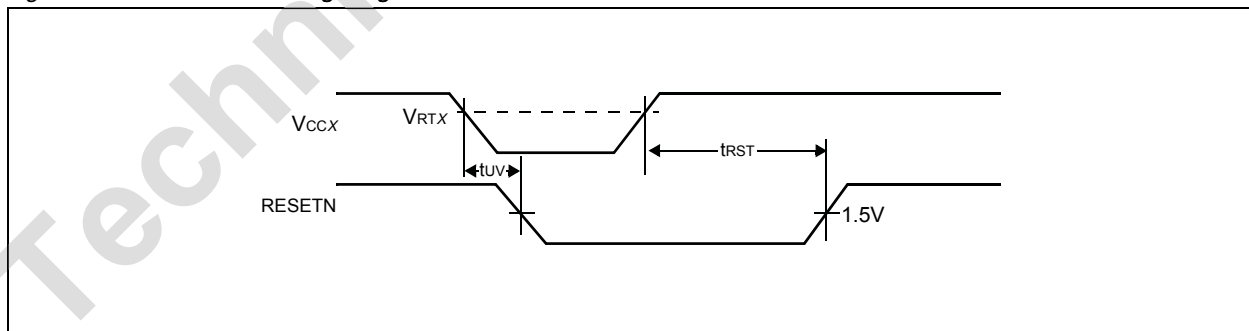
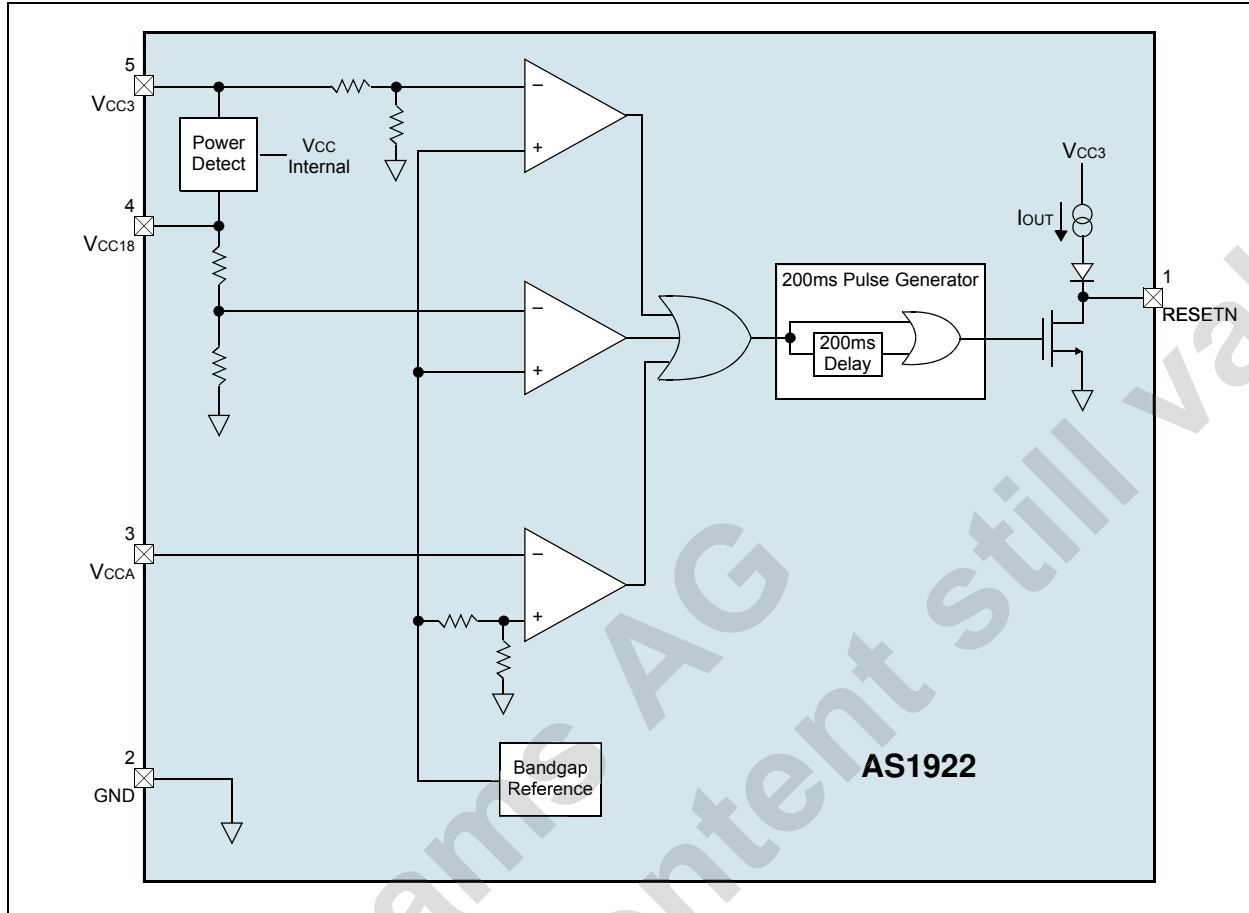

Figure 11. AS1922 Block Diagram





## 9 Application Information

### Supply Monitoring

The AS1920/AS1922 are low-power, high-accuracy triple-supply monitoring circuits with a single 200ms microprocessor reset output.

All Vcc inputs (VCC18, VCC3, and VCCA) must be above their thresholds to prevent a reset from being asserted. The AS1920/AS1922 will assert a reset during powerup, powerdown and brownout conditions on one or all of the Vcc inputs.

### Power Detect

The AS1920/AS1922 is powered from the 3V input pin (VCC3). The power detect circuitry ensures that the device pulls pin RESETN low as soon as the primary input pin is  $\geq 1V$  or the secondary input pin is  $\geq 1V$ .

### Powerup

The power detect circuitry ensures that RESETN will be low when either VCC18 or VCC3  $\geq 1V$ . As long as any one of the Vcc inputs is below its reset threshold, RESETN will stay at a logic low. When all Vcc inputs have stabilized, an internal timer will be started and RESETN will be driven high after 200ms.

### Powerdown

On powerdown, if any of the Vcc inputs drop below its threshold, RESETN is held at a logic low (0.3V) and is guaranteed until VCC3 and VCC18  $< 1V$ .

### Override Functions

As the trip points for VCC3 and VCC18 will always be greater than the trip point for VCCA, if pin VCCA is not used, it should be tied to VCC3 or VCC18. In a similar manner if pin VCC18 is not used it should be tied to VCC3. Tying VCC3 to VCC18 and operating from a 1.8V supply will assure the continuous assertion of RESETN.

**Note:** Pin VCC3 must be used in all configurations.

### Ensuring RESETN Valid for Supply Voltages $< 1V$

When the supplies drops below 1V the RESETN output current sink capability is greatly reduced. Stray currents and stray capacitance to signals other than GND can cause the RESETN output to float. This is not relevant for most applications since most microprocessors and other circuits do not operate with a supply voltage  $< 1V$ .

In applications where the RESETN output must be valid down to 0V, a pulldown resistor from pin RESETN to ground will ensure RESETN is held low (see Figure 12).

Figure 12. Typical Application w/Resistor on RESETN Output to GND

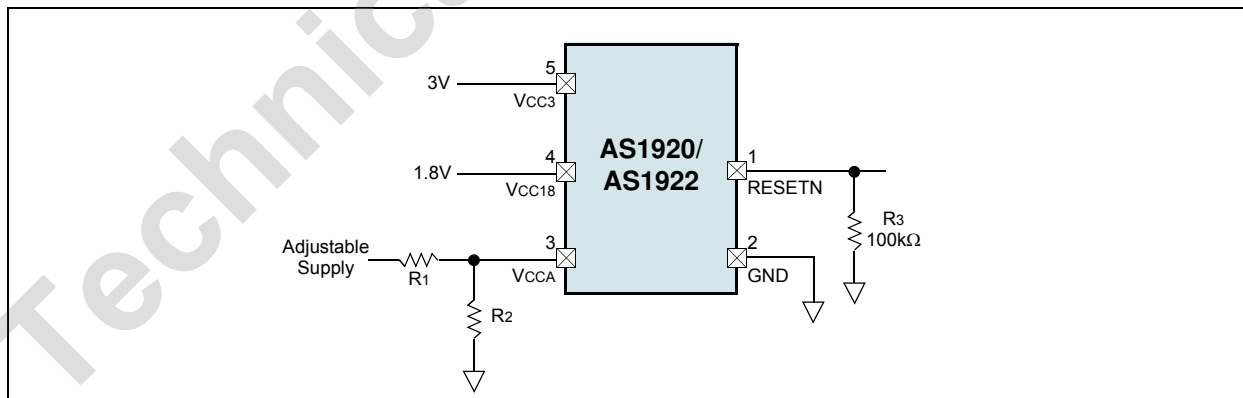

The value of the pulldown resistor (R3) is a trade-off between pulldown strength and loading of the RESETN pin. If the value of R3 is too large RESETN may still float, and if the value of R3 is too small it may load RESETN and also use excess supply current, therefore a value of 100kΩ is recommended for the pulldown resistor.

Figure 13. Triple-Supply Monitor (3V, 1.8V, Adjustable)

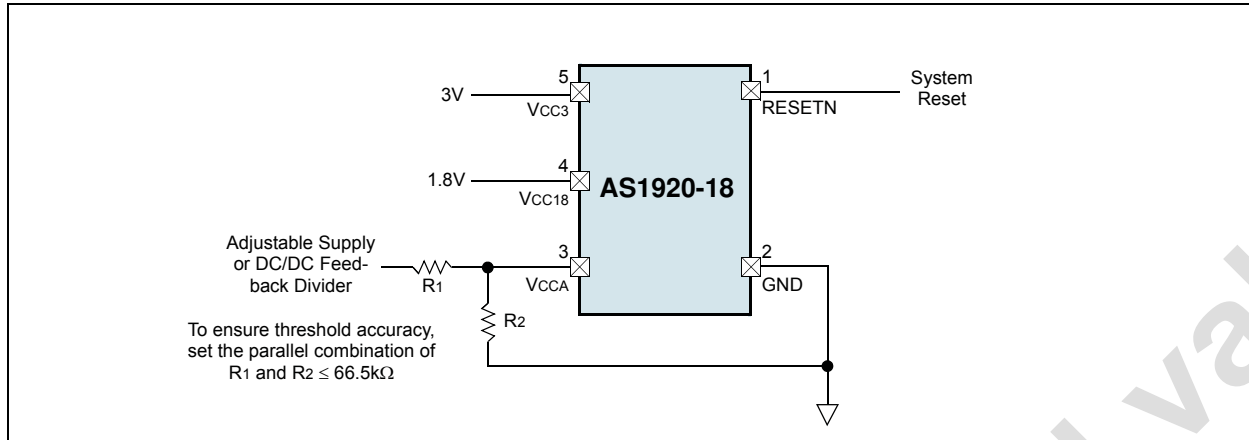

Figure 14. Dual-Supply Monitor (3V and 1.8V; Disable VCCA Input)

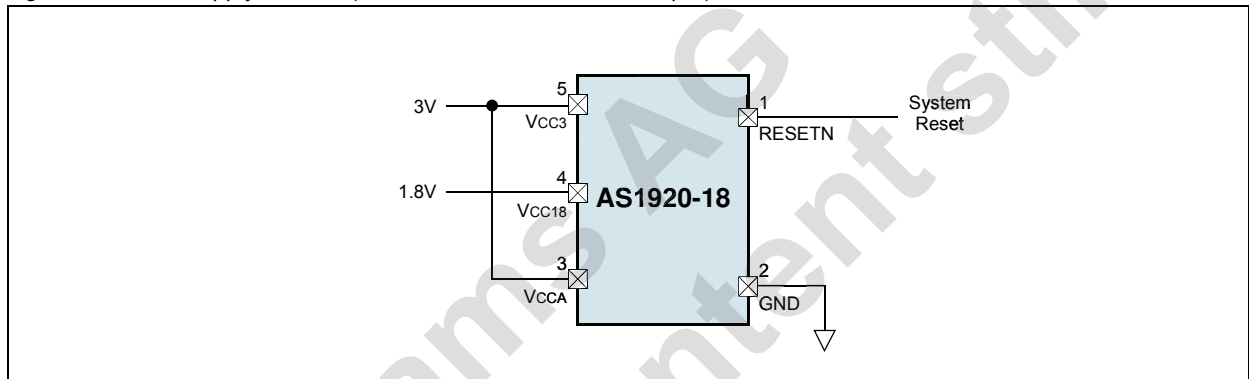

Figure 15. Dual-Supply Monitor (3V and Adjustable)

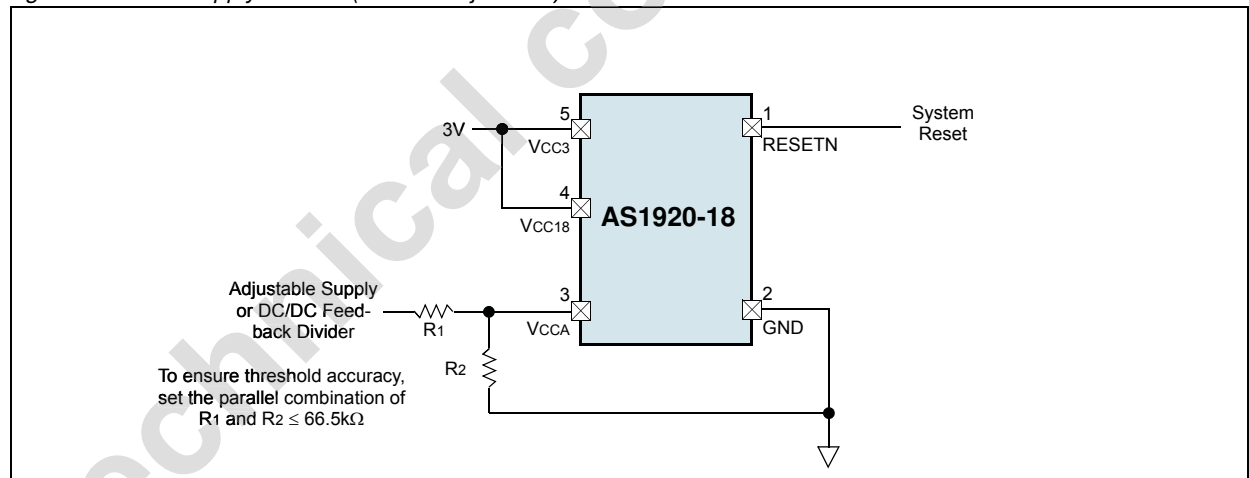

Figure 16. VCCA Tied to DC/DC Feedback Divider

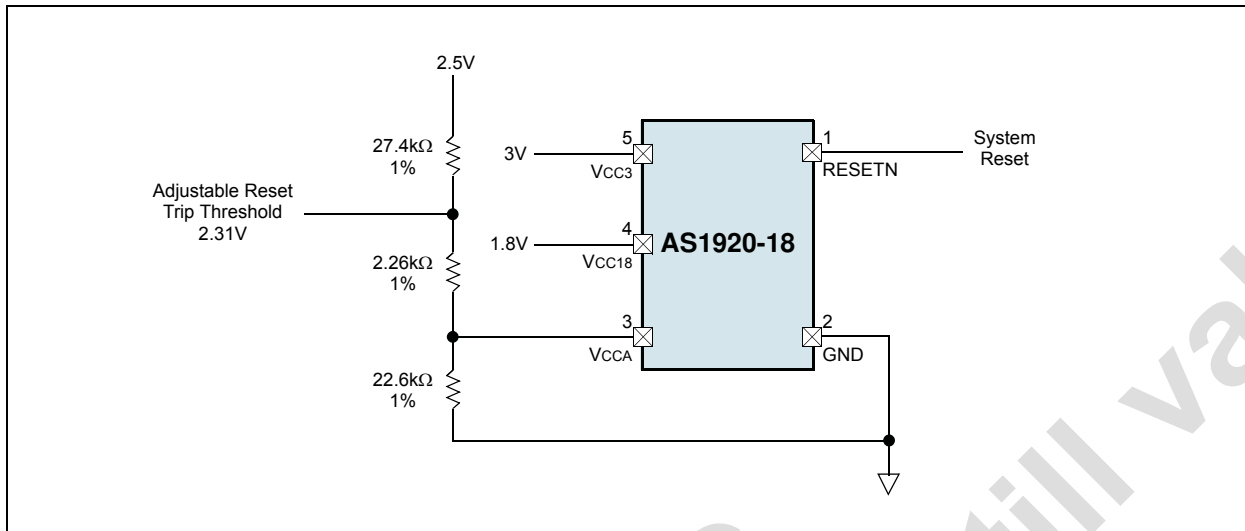
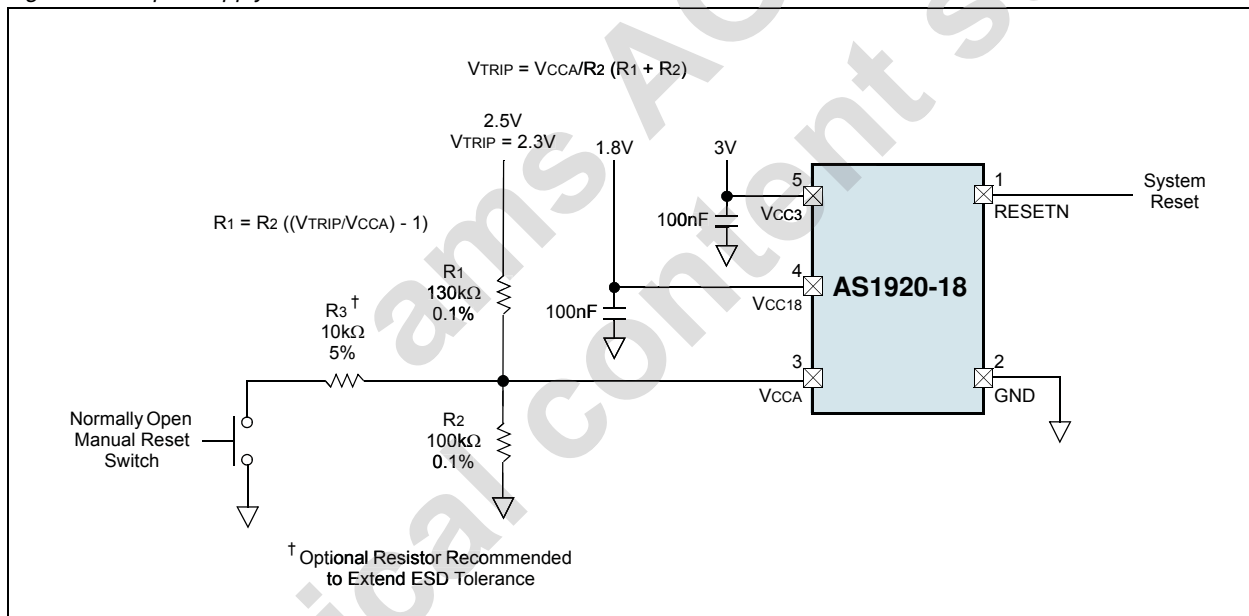

Figure 17. Triple-Supply Monitor w/Manual Reset Switch



## 10 Package Drawings and Markings

The devices are available in an 5-pin SOT23 package.

Figure 18. 5-pin SOT23 Package

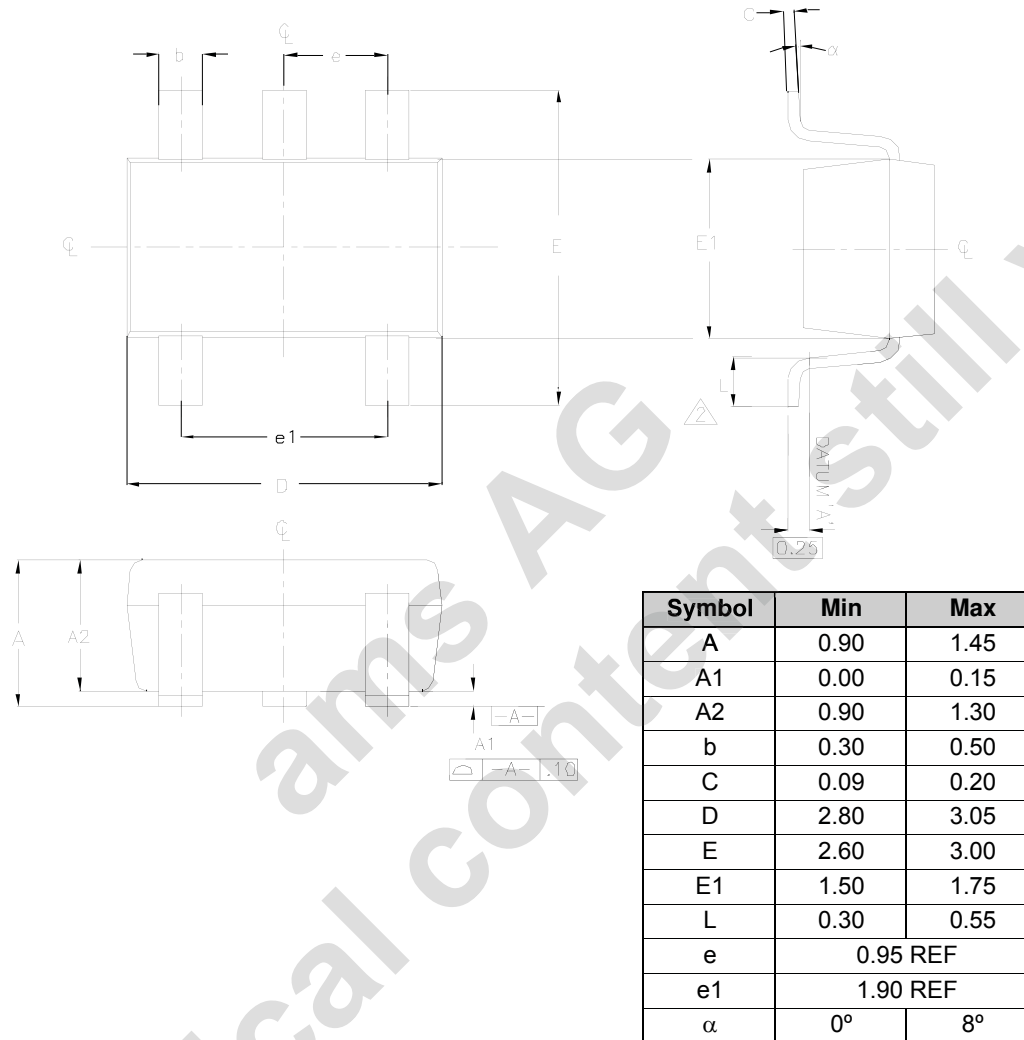

### Notes:

1. All dimensions in millimeters.
2. Foot length measured at intercept point between datum A and lead surface.
3. Package outline exclusive of mold flash and metal burr.
4. Package outline inclusive of solder plating.
5. Complies with EIAJ SC74.
6. PKG ST 0003 Rev A supersedes SOT23-D-2005 Rev C.

## Tape and Reel Pin1 Orientation

Figure 19. AS1920 Tape&Reel Pin1 Orientation

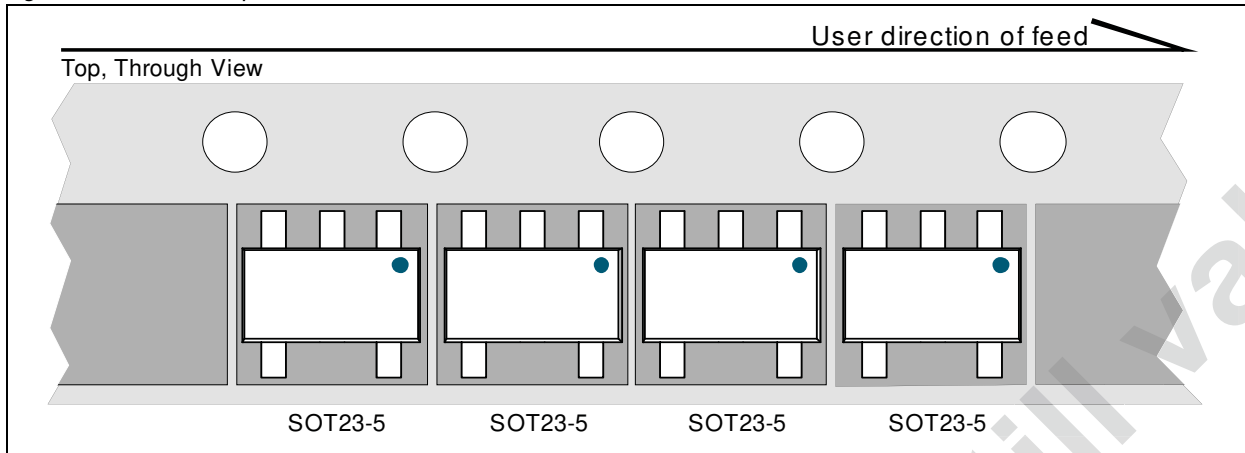
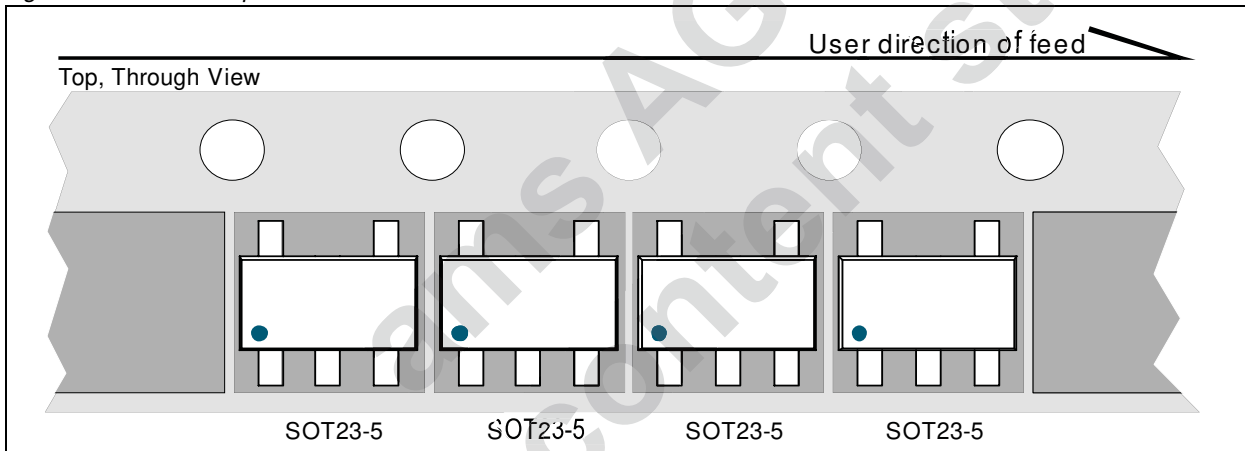

Figure 20. AS1922 Tape&Reel Pin1 Orientation



## 11 Ordering Information

The devices are available as the standard products shown in [Table 5](#).

Table 5. Ordering Information

Model	Marking	Description	Reset Type	Delivery Form	Package
AS1920-18-T	ASI1	Triple-Voltage Supervisory Circuit: 3V, 1.8V, and Adjustable.	Push/Pull	Tape and Reel	5-pin SOT23
AS1922-18-T	ASI2	Triple-Voltage Supervisory Circuit: 3V, 1.8V, and Adjustable.	Open-Drain	Tape and Reel	5-pin SOT23

ams AG  
Technical content still valid

## Copyrights

Copyright © 1997-2007, austriamicrosystems AG, Schloss Premstaetten, 8141 Unterpremstaetten, Austria-Europe. Trademarks Registered ®. All rights reserved. The material herein may not be reproduced, adapted, merged, translated, stored, or used without the prior written consent of the copyright owner.

All products and companies mentioned are trademarks or registered trademarks of their respective companies.

## Disclaimer

Devices sold by austriamicrosystems AG are covered by the warranty and patent indemnification provisions appearing in its Term of Sale. austriamicrosystems AG makes no warranty, express, statutory, implied, or by description regarding the information set forth herein or regarding the freedom of the described devices from patent infringement. austriamicrosystems AG reserves the right to change specifications and prices at any time and without notice. Therefore, prior to designing this product into a system, it is necessary to check with austriamicrosystems AG for current information. This product is intended for use in normal commercial applications. Applications requiring extended temperature range, unusual environmental requirements, or high reliability applications, such as military, medical life-support or life-sustaining equipment are specifically not recommended without additional processing by austriamicrosystems AG for each application. For shipments of less than 100 parts the manufacturing flow might show deviations from the standard production flow, such as test flow or test location.

The information furnished here by austriamicrosystems AG is believed to be correct and accurate. However, austriamicrosystems AG shall not be liable to recipient or any third party for any damages, including but not limited to personal injury, property damage, loss of profits, loss of use, interruption of business or indirect, special, incidental or consequential damages, of any kind, in connection with or arising out of the furnishing, performance or use of the technical data herein. No obligation or liability to recipient or any third party shall arise or flow out of austriamicrosystems AG rendering of technical or other services.



## Contact Information

### Headquarters

austriamicrosystems AG  
A-8141 Schloss Premstaetten, Austria

Tel: +43 (0) 3136 500 0

Fax: +43 (0) 3136 525 01

For Sales Offices, Distributors and Representatives, please visit:

<http://www.austriamicrosystems.com/contact>