



PK2200 Series

C-Programmable Controllers User's Manual

019-0015 • 071126-F

PK2200 User's Manual

Part Number 019-0015 • 071126-F • Printed in U.S.A.

© 1999–2007 Rabbit Semiconductor Inc. • All rights reserved.

Rabbit Semiconductor reserves the right to make changes and improvements to its products without providing notice.

No part of the contents of this manual may be reproduced or transmitted in any form or by any means without the express written permission of Rabbit Semiconductor.

Permission is granted to make one or more copies as long as the copyright page contained therein is included. These copies of the manuals may not be let or sold for any reason without the express written permission of Rabbit Semiconductor.

Trademarks

- Dynamic C[®] is a registered trademark of Rabbit Semiconductor Inc.
- Windows[®] is a registered trademark of Microsoft Corporation
- PLCBus[™] is a trademark of Rabbit Semiconductor Inc.

The latest revision of this manual is available on the Rabbit Semiconductor Web site, www.rabbit.com, for free, unregistered download.

Rabbit Semiconductor Inc.

www.rabbit.com

TABLE OF CONTENTS

About This Manual	vii
Chapter 1: Overview	11
Introduction	12
Standard Features	14
Flexibility and Customization Options	15
Development Kit	15
CE Compliance	16
Chapter 2: Getting Started	17
Connecting the PK2200 to a PC	18
Establishing Communication with the PK2200	19
Running a Sample Program	20
Chapter 3: Subsystems	21
Subsystem Overview	22
Processor Core	23
CPU	23
Microprocessor Supervisor/Watchdog Timer	23
Static RAM	23
EPROM/Flash EPROM	23
EEPROM	24
Real Time Clock (RTC)	24
Digital Inputs	24
Digital Outputs	27
Serial Communication	29
Serial Channel Configuration	29
Keypad and Display	31
Chapter 4: System Development	33
Changing Modes	34
Setting the Mode	34
Development Options	35
Memory Options	35
Battery-Backed RAM	35
EPROM	36
Flash EPROM	36

Digital Inputs	36
Using the Digital Inputs	36
Interrupt Inputs	36
High Speed DMA Counter	36
Digital Outputs	37
Using the Digital Outputs	37
Serial Communication	38
Receive and Transmit Buffers	38
Echo Option	39
CTS/RTS Control	39
XMODEM File Transfer	39
Modem Communication	39
Interrupt Handling for Z180 Port 0	41
Remote Downloading	41
Developing an RS-485 Network	42
Keypad and LCD	43
Using the Keypad and Display	43
PK2200 Keypads	43
Keypad Insert Templates	44
Keypad Codes	45
PK2200 LCDs	46
Graphic LCD Status	46
Bitmapped Graphics	47
Chapter 5: Software Reference	49
Software Drivers	50
Real Time Clock (RTC)	50
EEPROM	51
Digital Inputs and Outputs	52
Digital Input Drivers	52
Digital Output Drivers	54
LCD and Keypad	55
Sample Programs	62
Communication Sample Programs	63
PK2240 Sample Programs	64
Appendix A: Troubleshooting	65
Out of the Box	66
Dynamic C Will Not Start	67
Dynamic C Loses Serial Link	67
PK2200 Repeatedly Resets	67
Common Programming Errors	68

Appendix B: Specifications	69
General Specifications	70
Hardware Mechanical Dimensions	71
High Voltage Driver Specifications	75
Environmental Temperature Constraints	75
Connectors	76
Header Locations and Jumper Settings	76
Appendix C: Power Management	79
Power Failure Detection Circuitry	80
Power Failure Sequence of Events	80
Recommended Power Fail Routine	82
Appendix D: Interrupt Vectors and I/O Addresses	85
Interrupt Vectors	86
Jump Vectors	87
EEPROM Addresses	88
Processor Register Addresses	89
PK2200 Peripheral Addresses	91
Appendix E: PLCBus	95
PLCBus Overview	96
Allocation of Devices on the Bus	100
4-Bit Devices	100
8-Bit Devices	101
Expansion Bus Software	101
Appendix F: Backup Battery	107
Battery Life and Storage Conditions	108
Replacing Soldered Lithium Battery	108
Battery Cautions	109
Index	111

Blank

ABOUT THIS MANUAL

This manual provides instructions for installing, testing, configuring, and interconnecting the Z-World PK2200 controller.

All product references in this manual are made to the PK2200 series. The term “PK2200” is used as a generic term referring to any of the PK2200 series. Where necessary, specific model numbers are used.

Instructions are also provided for using Dynamic C[®] functions.

Assumptions

Assumptions are made regarding the user's knowledge and experience in the following areas.

- Ability to design and engineer the target system that a PK2200 will control.
- Understanding of the basics of operating a software program and editing files under Windows on a PC.
- Knowledge of the basics of C programming.



For a full treatment of C, refer to the following texts.

The C Programming Language by Kernighan and Ritchie
and/or

C: A Reference Manual by Harbison and Steel

- Knowledge of basic Z80 assembly language and architecture.



For documentation from Zilog, refer to the following texts.

Z180 MPU User's Manual

Z180 Serial Communication Controllers

Z80 Microprocessor Family User's Manual

Acronyms

Table 1 lists and defines the acronyms that may be used in this manual.







Table 1. Acronyms

Acronym	Meaning
EPROM	Erasable Programmable Read-Only Memory
EEPROM	Electrically Erasable Programmable Read-Only Memory
LCD	Liquid Crystal Display
LED	Light-Emitting Diode
NMI	Nonmaskable Interrupt
PIO	Parallel Input/Output Circuit (Individually Programmable Input/Output)
PRT	Programmable Reload Timer
RAM	Random Access Memory
RTC	Real-Time Clock
SIB	Serial Interface Board
SRAM	Static Random Access Memory
UART	Universal Asynchronous Receiver Transmitter

Icons

Table 2 displays and defines icons that may be used in this manual.

Table 2. Icons

Icon	Meaning	Icon	Meaning
	Refer to or see		Note
	Please contact	Tip	Tip
	Caution		High Voltage
	Factory Default		

Conventions

Table 3 lists and defines the typographic conventions that may be used in this manual.

Table 3. Typographic Conventions

Example	Description
while	Courier font (bold) indicates a program, a fragment of a program, or a Dynamic C keyword or phrase.
// IN-01...	Program comments are written in Courier font, plain face.
<i>Italics</i>	Indicates that something should be typed instead of the italicized words (e.g., in place of <i>filename</i> , type a file's name).
Edit	Sans serif font (bold) signifies a menu or menu selection.
...	An ellipsis indicates that (1) irrelevant program text is omitted for brevity or that (2) preceding program text may be repeated indefinitely.
[]	Brackets in a C function's definition or program segment indicate that the enclosed directive is optional.
< >	Angle brackets occasionally enclose classes of terms.
a b c	A vertical bar indicates that a choice should be made from among the items listed.

Pin Number 1

A black square indicates pin 1 of all headers.

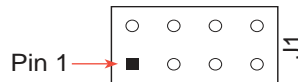

Measurements

All diagram and graphic measurements are in inches followed by millimeters enclosed in parenthesis.

Blank



CHAPTER 1: OVERVIEW

Chapter 1 provides a comprehensive overview and description of the PK2200.

Introduction

The PK2200 is an inexpensive control computer well suited for a variety of applications in areas such as packaging, materials handling, and process control.

Figure 1-1 illustrates the PK2200 with the 2×20 character LCD and a 2×6 keypad.

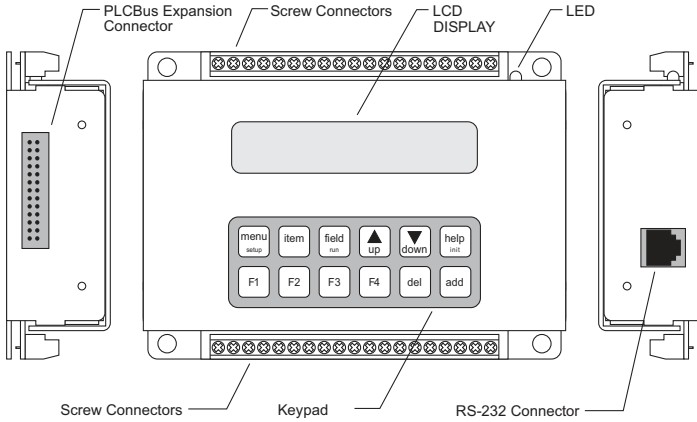

Figure 1-1. PK2200 with Character LCD and Keypad

Figure 1-2 illustrates the PK2240 with the 128×64 graphic LCD and a 4×3 keypad.

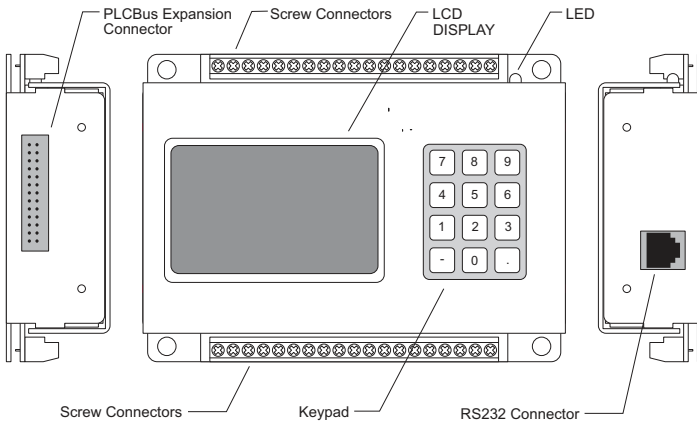

Figure 1-2. PK2240 with Graphic LCD and Keypad

Figure 1-3 illustrates the PK2200 without an enclosure.

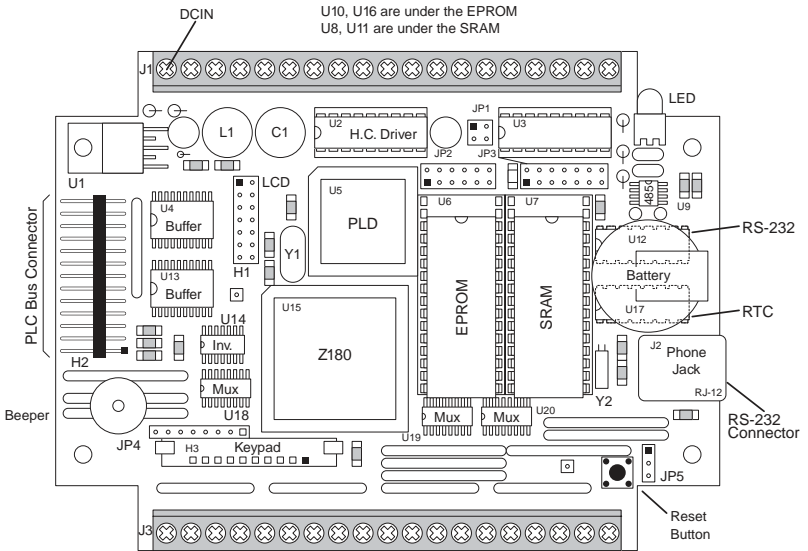

Figure 1-3. PK2200 Without Enclosure

Standard Features

The PK2200 series includes the following standard features:

- Compact size: 4" × 5.5" × 1.34"
- 16 protected digital inputs for detecting contact closures, counting pulses, or detecting voltage input signals.
- 14 high-current digital outputs, suitable for driving relays, solenoids, or lamps.
- RS-485 and RS-232 serial ports for external communication and controller networking using links up to several kilometers
- 9.216 MHz clock with 18.432 MHz optional
- Switching power supply for reduced power consumption. The PK2200 consumes less than 2 W at 18.432 MHz.
- A PLCBus port allows system expansion including relays, A/D converters, D/A converters, UARTs and more.
- EPROM (up to 512K) or flash EPROM (up to 256K) for program and nonvolatile data storage.
- Battery-backed RAM (up to 512K).
- Battery-backed real-time clock with time and date functions.
- Programmable timers.
- EEPROM (512 byte standard) for storing system information.
- Watchdog timer and power-fail detection circuitry for improved system reliability.

Table 1-1 lists PK2200 series models and each model's standard features.

Table 1-1. PK2200 Series Standard Features

Model	Features
PK2200	18.432 MHz clock, 2 × 20 character LCD, 2 × 6 keypad, rugged metal enclosure.
PK2210	9.216 MHz clock, 2 × 20 character LCD, 2 × 6 keypad, rugged metal enclosure.
PK2220	18.432 MHz clock, 2 × 20 character LCD, 2 × 6 keypad
PK2230	9.216 MHz clock.
PK2240	18.432 MHz clock, 128K flash EPROM, 128 × 64 backlit graphic LCD, 4 × 3 keypad, rugged metal enclosure.

Flexibility and Customization Options

The PK2200 is available with either quick-release pluggable terminals or fixed screw terminals.

For added flexibility, special order the PK2200 Series controller with the following options installed.

- Backlit character LCD (for PK2200 and PK2210 only).
- 128K or 512K battery-backed RAM.
- 128K flash EPROM for program and nonvolatile data storage.
- High-voltage sourcing drivers.

For quantity orders, customization of the PK2200 modified is available to better suit your application. A wide variety of options are available for I/O, memory, and packaging.



For details on PK2200 customization, contact your Z-World Sales Representative at (530) 757-3737.

Development Kit

The PK2200 Development Kit contains all the tools required for fast development. The kit includes the following items:

- Programming cable
- Power supply
- 128K flash EPROM
- High-current sourcing drivers
- Demonstration board that simulates I/O
- User's manual with schematics

CE Compliance

The PK2200 has been tested by an approved competent body, and was found to be in conformity with applicable EN and equivalent standards. Note the following requirements for incorporating the PK2200 in your application to comply with CE requirements.



- The power supply provided with the Development Kit is for development purposes only. It is the customer's responsibility to provide a clean DC supply to the controller for all applications in end-products.
- Fast transients/burst tests were not performed on this controller. Signal and process control lines longer than 3 m should be routed in a separate shielded conduit.
- The PK2200, PK2210, PK2220, and PK2230 were tested to Industrial Immunity Standards. The PK2240 has been tested to Light Industrial Immunity standards. Additional shielding or filtering may be required for the PK2240 for an industrial environment.
- The PK2200 has been tested to EN55022 Class A emission standards. Additional shielding or filtering will be required to meet Class B emission standards.



Visit the “Technical Reference” pages of the Z-World Web site at <http://www.zworld.com> for more information on shielding and filtering.



*CHAPTER 2: **GETTING STARTED***

Chapter 2 provides instructions for connecting the PK2200 to a PC and running a sample program.

Connecting the PK2200 to a PC

The PK2200 is programmed with a PC through an RS-232 port using the programming cable provided in the Development Kit.

To connect the PK2200 to a PC use the following steps:

1. Install Dynamic C as described in your Dynamic C manuals.
2. Using the supplied adapter, connect the programming cable from the PK2200's RJ-12 (**J2**) socket to the appropriate COM port of your computer.

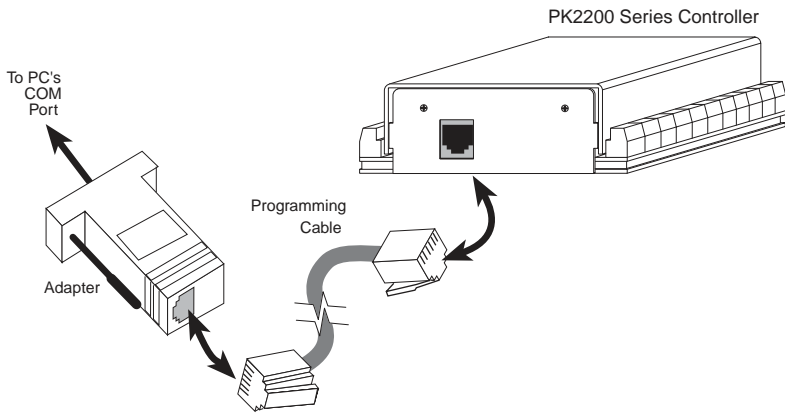

Figure 2-1. Programming Connections



Only use the supplied adapter and programming cable.



The supplied 24 V wall power supply is sufficient for all power requirements. The PK2200 accepts from 9 V to 36 V DC.

3. Connect the supplied 24V DC power supply as follows.
 - Connect the lead with the red sleeving to the +DC terminal of the PK2200 (J1 terminal 1).
 - Connect the other lead to the GND terminal (J1 terminal 3).

Figure 2-2 illustrates the power supply connections.

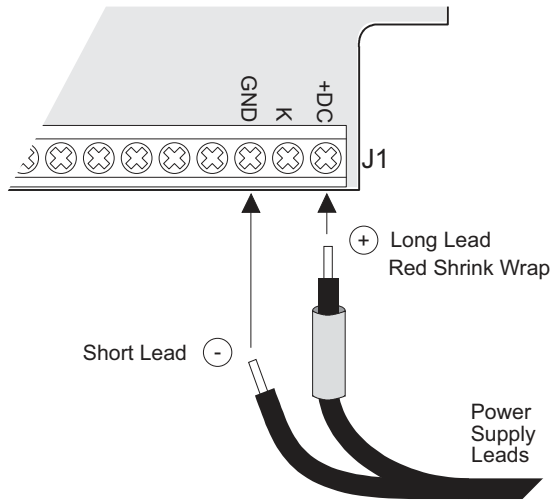

Figure 2-2. Power Supply Connection

4. Plug the power supply into a wall socket.

The PK2200 is now ready to run.

Establishing Communication with the PK2200

To establish communication with the PK2200 use the following steps.

1. Double-click the Dynamic C icon to start the software. Note that each time you start Dynamic C, communication with the attached PK2200 is attempted.
2. If the communication attempt is successful, no error messages are displayed.



If an error message such as **Target Not Responding** or **Communication Error** is displayed, see Appendix A, “Troubleshooting.”



After making necessary changes to establish communication between a PC and the PK2200, use the Dynamic C shortcut **<Ctrl-Y>** to reset the controller and initialize communication.

Running a Sample Program

To run a sample program on the PK2200 use the following steps.

1. Open the sample program **CDEMO_RT.C** located in the **SAMPLES\CPLC** Dynamic C subdirectory.
2. Compile the program by pressing **F3** or by choosing **Compile** from the compile menu. Dynamic C compiles and downloads the program into the PK2200's memory.

During compilation, Dynamic C rapidly displays several messages in the compiling window. This condition is normal.



If an error message such as **Target Not Responding** or **Communication Error** is displayed, see Appendix A, "Troubleshooting."

3. Run the program by pressing **F9** or by choosing **Run** from the **Run** menu.
4. To halt the program, press **<Ctrl-Z>**.
5. To restart program execution, press **F9**.



Refer to Z-World's *Dynamic C Technical Reference User's Manual* for instructions regarding the use of the Dynamic C development system.



CHAPTER 3: **SUBSYSTEMS**

Chapter 3 describes the various PK2200 subsystems and interfaces, software drivers and sample programs.

Subsystem Overview

The PK2200 is composed of several subsystems. The following list of subsystem elements is illustrated in Figure 3-1.

- Processor core
- Protected digital inputs
- High-voltage driver outputs
- Serial communication channels
- Keypad and LCD

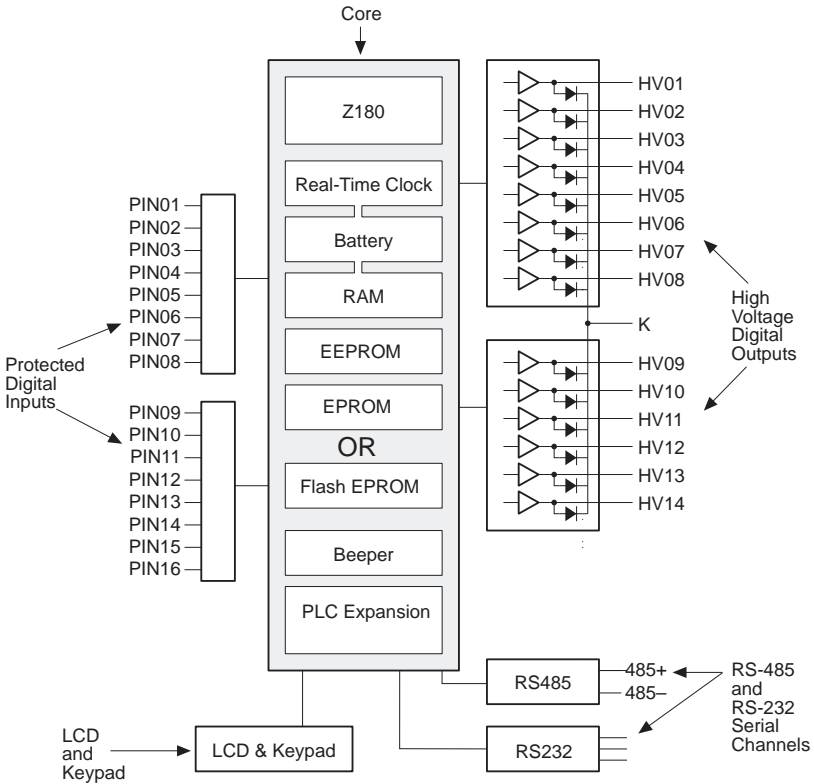

Figure 3-1. PK2200 I/O Systems Block Diagram

Processor Core

The PK2200's processor core is composed of the CPU, microprocessor supervisor/watchdog timer, battery-backed static RAM, EPROM/flash EPROM, EEPROM, and RTC.

CPU

The PK2200 is available with either 9.216 MHz or 18.432 MHz CPU clock speeds. The 18.432 MHz clock improves system performance and allows baud rates up to 11,500 bps. PK2200s with the 9.216 MHz option are limited to 57,600 bps. The system clock speed is a 16-bit value stored at location 0x108 in the EEPROM. The clock speed is expressed in multiples of 1200 Hz. The value read for 9.216 MHz clocks is 7,680 and for 18.432 MHz clocks the value read is 15,360.

Microprocessor Supervisor/Watchdog Timer

The microprocessor supervisor/watchdog timer provides the following functions for the PK2200.

- Power monitoring for the processor. Protects the system during brownouts and fluctuating power conditions. The supervisor provides a power-fail output that can be monitored by the processor, allowing the processor to save important information before a complete power-fail and then halt operation until power is fully restored.
- Battery backup for the static RAM. Allows data to remain intact even when power is removed from the PK2200.
- Watchdog timer function. Resets the system in the event of a software or hardware error that causes the processor to enter an infinite loop.

Static RAM

Static RAM is normally used to store program data. RAM can also be used to store program code. This is especially useful during software development because it allows quick program changes without having to change EPROMs.

EPROM/Flash EPROM

EPROMs offer a low-cost, permanent medium for storing program code and constant data. Once the application program is fully functioning and debugged, an EPROM can be programmed and installed. EPROMs can be quickly and easily duplicated, and are easy to install.

Even though slightly more expensive than standard EPROM, flash EPROM offers the following benefits.

- In-system programmability.
- Remote downloading of program code and data.
- Easier to reprogram.
- Erases quicker without a special eraser.

EEPROM

EEPROM offers a separate area for storing permanent or semi-permanent information such as clock speed, network address, calibration coefficients, and installation data. The EEPROM can be write-protected using a jumper, which prevents data from being accidentally overwritten.

Real Time Clock (RTC)

The RTC provides the application program with the current date and time of day. The PK2200's battery keeps the RTC running even when the power is off. The RTC is accurate to about one second a day and compensates for leap years and variances in the number of days in each month.

Digital Inputs

The PK2200's 16 digital inputs (PN01 through PN16) are flexible and robust. Configurable pull-up or pull-down resistors and high voltage protection circuits allow the inputs to detect switch contacts, relay contacts, outputs from open-collector transistor devices, logic level outputs, and high voltage outputs. In addition, two inputs may be used for generating interrupts and another two may be used for high-speed counting. The protected digital inputs have the following features:

- Nominal input voltage range of -20 V to $+24\text{ V}$.
- Protection against overloads over the range of -48 V to $+48\text{ V}$.
- Logic level detection.
- Configurable pull-ups and pull-downs. Jumper the digital inputs in groups of eight to pull up to $+5\text{ V}$ or down to GND through $4.7\text{ k}\Omega$ resistors.

The nominal voltage range for the protected digital inputs is -20 V to $+24\text{ V}$. The inputs are protected against overvoltages in the range -48 V to 48 V ; however, inputs should not be regularly subjected to voltages outside the nominal voltage range.

Logic-level signals can also be detected using the digital inputs. The logic threshold is nominally 2.5 V . The maximum guaranteed low voltage is 1.25 V . The minimum guaranteed high voltage is 3.75 V .

The digital inputs can be pulled up to +5 V or down to GND by installing jumpers on JP2. When jumpered, the digital input line impedance is 4.7 k Ω in the range 0–5 V for inputs 1–10 and 15–16. The impedance on inputs 11–14 is approximately 1.5 k Ω . Outside this range, the input impedance is greater than 3.9 k Ω for inputs 1–10 and 15–16. Jumper JP2 connects the inputs to pull-up or pull-down resistors. Table 3-1 lists the JP2 jumper settings and Figure 3-2 illustrates JP2 jumper settings.

Table 3-1. JP2 Digital Input Jumper Settings

Pins Jumpered	Inputs	Configuration
7–9	1–4 and 9–12	Pulled up
8–10	5–8 and 13–16	Pulled up
9–11	1–4 and 9–12	Pulled down
10–12	5–8 and 13–16	Pulled down

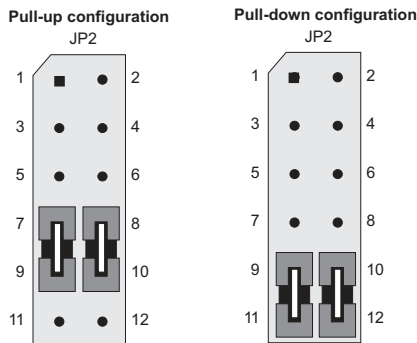

Figure 3-2. JP2 Digital Input Jumper Settings

The Figure 3-3 illustrates a typical digital input line.

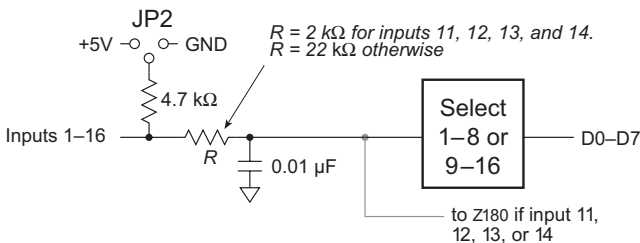



Figure 3-3. Typical Digital Input

Inputs 11–14, in addition to the protected digital input function, have the capabilities listed in Table 3-2.

Table 3-2. Digital Input 11-14 Alternate Functions

Input	Z180 Signal	Function
11	/INT0	Interrupt for user programs
12	/INT2	Interrupt for user programs
13	CKA0/DREQ0	DMA channel 0, used for counting
14	/DREQ1	DMA channel 1, used for counting

Inputs 11 and 12 can be used to generate hardware interrupts on the PK2200 CPU. Input 11 is connected to /INT0 and input 12 is connected to /INT2. With Dynamic C, you can easily implement service routines for these interrupts. Table 3-2 lists the alternate functions for digital inputs 11 through 14.

 Refer to the *Dynamic C Technical Reference User's Manual* for more information on writing interrupt service routines.

Inputs 13 and 14 are connected to the CPU's DMA channels. These inputs may be used for counting high-speed digital signals. For high-speed counting (above 5 kHz), remove capacitor network CN2.

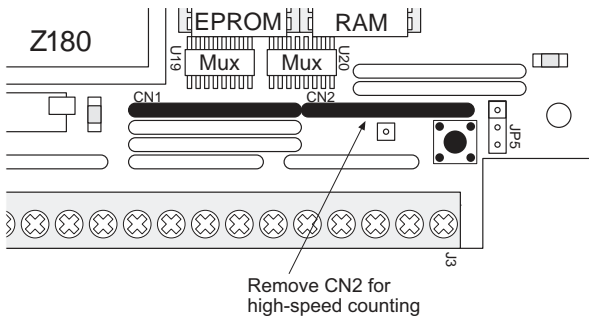



Figure 3-4. CN2 Capacitor Networks

 Removing CN2 from the PK2240 disables the filtering on channels IN5, IN6, IN7, IN8, IN13, IN14, IN15, and IN16

The high-speed counters and can perform a variety of functions including time stamping, pulse width measurement and duty cycle measurement.

Digital Outputs

The PK2200's 14 digital outputs (HV01 through HV14) provide high-voltage, high-current digital outputs for your application. Sinking and optional sourcing drivers will drive a variety of loads including inductive loads such as relays, small solenoids, or stepping motors.

Note the following points regarding the digital outputs:

- Each output is individually addressable.
- Each output includes a protective diode that returns inductive spikes to the power supply.
- Sinking drivers are standard. Sourcing drivers are optional. Both drivers must be of the same type, either sinking or sourcing.

The total number of outputs that can be on simultaneously is subject to chip power limits and ambient temperature. There are power limitations on each channel as well as the entire driver IC. Eight channels, HV1–HV8, are driven by one driver IC. The other six, HV9–HV14, are driven by the other driver IC. Since fewer outputs are being driven by the HV9–HV14 driver IC, the current limit on these channels is higher than on the HV1–HV8 channels.

Figure 3-5 illustrates the configuration for the ULN2803 sinking driver.

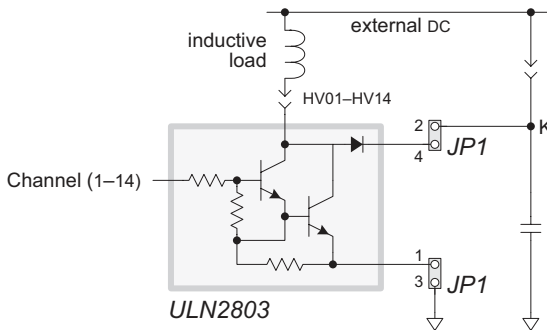

Figure 3-5. Sinking Driver Configuration

Note the following points regarding the ULN2803 sinking driver chip.

- Outputs pull low (sink current) when turned on.
- The chip's rating is 48 V and 500 mA maximum per channel, subject to the chip's thermal limits and ambient temperature.
- With all channels on, each channel can sink up to 170 mA continuously (100% duty cycle) as long as the chip temperature is less or equal to 50°C. At 70°C the current must be reduced to 140 mA or less.

Figure 3-6 illustrates the connection for the UDN2985A sourcing driver. (Note the connections on header JP1.)

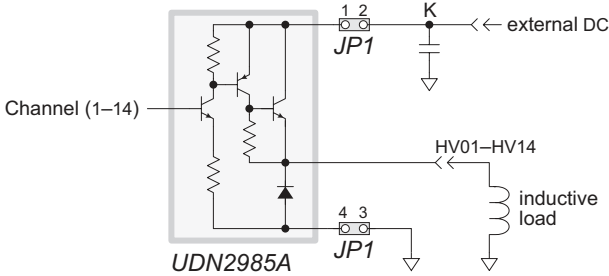

Figure 3-6. Sourcing Driver Configuration

Note the following points regarding the UDN2985A sourcing driver.

- Outputs pull high (source current) when turned on.
- The chip’s rating is 30 V and 250 mA maximum per channel, subject to the chip’s thermal limits and ambient temperature.
- With all channels on, each channel can source up to 170 mA continuously (100% duty cycle) as long as the chip temperature is less or equal to 50°C. At 70°C the current must be reduced to 140 mA or less.

Header JP1 configures the outputs for either sourcing or sinking drivers. Table 3-3 lists the JP1 jumper configurations shown in Figure 3-7.

Table 3-3. JP1 High-Current Output Jumper Settings

JP1 Setting	Description
1-3, 2-4	Sinking Outputs
1-2, 3-4	Sourcing Outputs

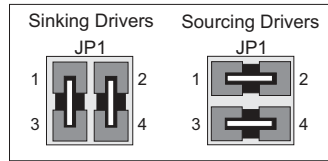



Figure 3-7. JP1 Digital Output Jumper Settings

Tip If incandescent lights are driven, use a series resistor to limit the incoming current.

 See Appendix B: “Specifications” for more detailed information on the sinking and sourcing drivers.

Serial Communication

Two serial ports support asynchronous communication at baud rates from 300 bps to 57,600 bps on 9.216 MHz versions up to 115,200 bps with the 18.432 MHz versions. The serial ports can be configured as follows:

- Two 3-wire RS-232 ports.
- One 5-wire RS-232 port (with RTS and CTS) and one half-duplex RS-485 port.

The RJ-12 phone jack connector J2 supports full-duplex RS-232 communication with handshake lines. The RS-485 lines (J1 terminals 18 and 19) provide half-duplex asynchronous communication over twisted pair wires, up to 3 kilometers. The RS-232 ports on the PK2200 support a subset of the RS-232 standard that is in common use.

Serial Channel Configuration

Figure 3-8 illustrates the configuration of two 3-wire RS-232 channels.

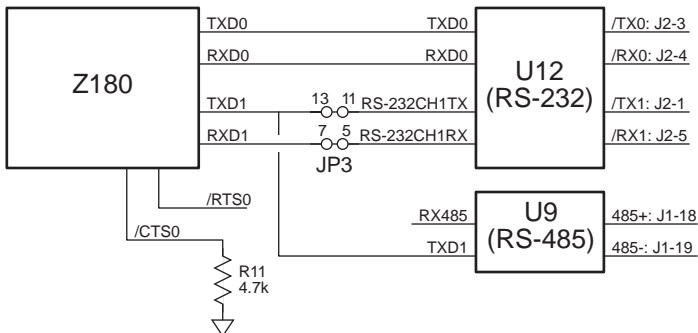

Figure 3-8. Two RS-232 Channels

Figure 3-9 illustrates the configuration of one 5-wire RS-232 channel and one half-duplex RS-485 channel.

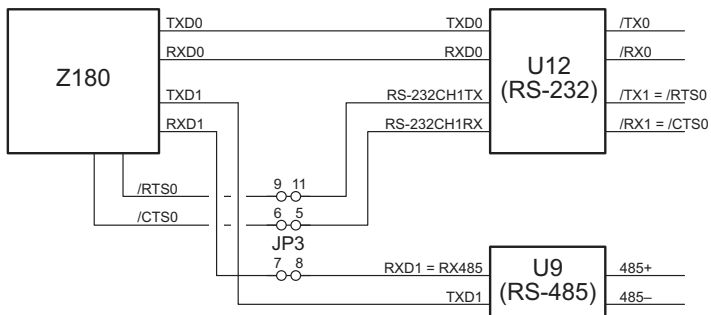

Figure 3-9. RS-232 and RS-485

Table 3-4 lists JP3 jumper settings and Figure 3-10 illustrates jumper setting configurations for the two serial channels. If only one RS-232 channel is desired, use one of the first two configurations. With these configurations, the RS-485 port is also active on the second Z180 serial channel (Z1). Unless the application software explicitly enables Z1, the RS-485 channel has no effect on the Z180. The RS-485 is connected to Z1 in the first two configurations in order to keep the Z180 CMOS input (RXA1) from floating.

Table 3-4. JP3 Serial Communication Jumper Settings

JP3 Jumpered Pins	Serial Communication Configuration
5-6, 7-8, 9-11	One 5-wire RS-232 channel (Z180 Port 0) with RTS/CTS FD One RS-485 channel (port 1)
7-8	One 3-wire RS-232 One RS-485
5-7 11-13	Two 3-wire RS-232

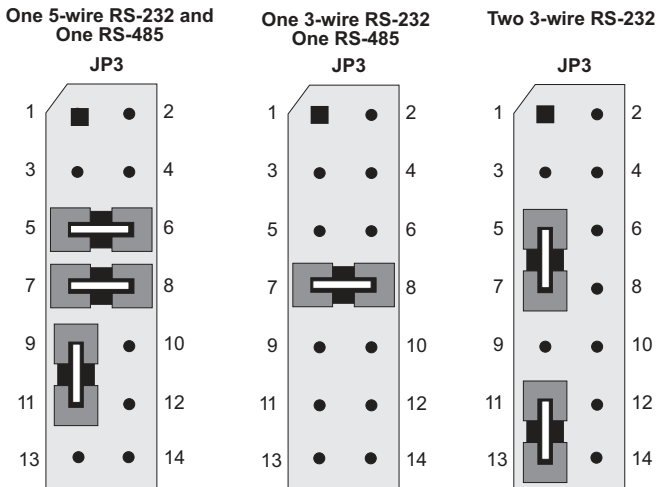

Figure 3-10. JP3 Jumper Settings

Keypad and Display

The PK2200 Series supports operator I/O through both keypad and LCD. The following two standard operator I/O configurations are available on PK2200 controller models with enclosures:

- 2-row by 20-column character LCD module plus a 2-row by 6-column keypad.
- 128-column by 64-row backlit graphic LCD module plus a 4-row by 3-column keypad.

The character LCD module is also available with an LED backlighting option and the graphic LCD has a software controllable electroluminescent backlighting installed as a standard feature. Table 3-5 lists and describes header connections and functions.

Table 3-5. Header Connections and Function

Header	Function
H1	The LCD connector. Connect a 14-wire ribbon cable from the LCD to this header. Not used on the PK2240.
H2	The PLCBus expansion connector. This connector supports the “LCD bus” as well. Use a 26-pin ribbon cable to attach PLCBus devices to the PK2200.
H3	The keypad connector. Connect a 10-wire flat flexible cable from the keypad to this header. Not used on the PK2240.

The PK2200 series also interfaces easily with the Z-World line of operator interface products. Operator interfaces are available with a variety of keypad sizes and LCD configurations.



For more information on Z-World operator interfaces, contact your Z-World Sales Representative at (530) 757-3737.

Blank



*CHAPTER 4: **SYSTEM DEVELOPMENT***

Chapter 4 describes system development using the PK2200 interfaces and presents some sample programs to illustrate their use.

Changing Modes

The operating mode of the PK2200 is determined during power-up initialization. If a valid program is found in EPROM, then it is executed. Otherwise, the operating mode is determined by the jumper settings on JP4 or by keypress combinations. Following are the possible modes of operation:

- Run a program stored in RAM or flash EPROM.
- Prepare for Dynamic C programming using the RS-232 port.

The mode can be changed by either of the following two methods:

1. Set jumper JP4 to the desired position. Remove power from the PK2200. Apply power to the PK2200.
2. With power off, hold down the appropriate keys on the keypad and apply power. Refer to Figure 4-1 for the appropriate keypress combinations.

You will hear a series of beeps indicating that the mode has been set.



The PK2240 has a sample program loaded at the factory that will run automatically when the PK2240 is powered. You can set the PK2240 to program mode using the procedures above. All other models are preconfigured for program mode.

Setting the Mode

Figures 4-1, 4-2, and 4-3 illustrate keypad and jumper settings for run and program modes for different PK2200 configurations. The keypress combination for the 3x4 keypad will work only with the PK2240 model. The keypress combination for the 2x6 keypad will work with any model with a 2x6 keypad. If programming at normal 19,200 bps, then press the “menu setup” and “up pgm” keys. If programming at 28,800 bps, then press the “menu setup” and the “down pgm” keys. You may instead set the programming baud rate with jumpers on JP4.

At startup, a PK2200 can also be put into run mode by placing a jumper across pin 6 and pin 7 of JP4.

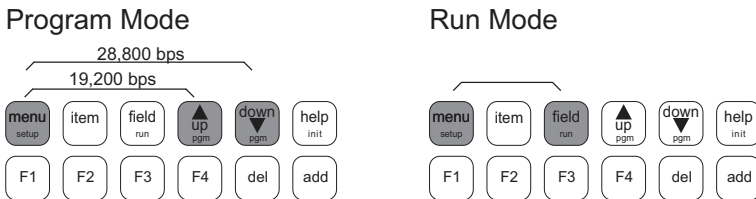

Figure 4-1. 2x6 Keypad Mode Settings

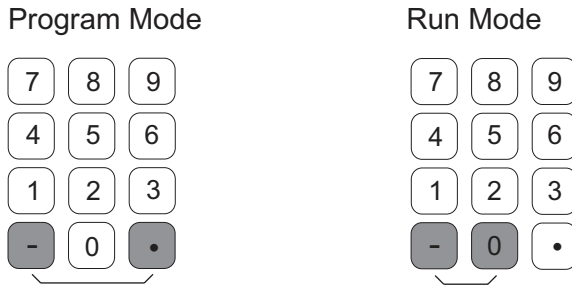

Figure 4-2. 3x4 Keypad Mode Settings



Figure 4-3. JP4 Mode Settings



Do not jumper more than one pair of pins to configure a mode.

Development Options

Memory Options

Programs for the PK2200 are written and compiled on a PC and then downloaded to the PK2200 memory and executed. There are three memory options for program storage on the PK2200:

- (1) Battery-backed RAM,
- (2) EPROM,
- (3) Flash EPROM.

Battery-Backed RAM

Battery-backed RAM is a standard feature on every PK2200. RAM is available in 32K, 128K, and 512K. During development you can use RAM to download and execute programs. This speeds development because you don't need to program and erase EPROMs. Once a program is fully debugged and running, you can create a binary file and use an EPROM burner to store the program in EPROM. Since the RAM is used to store both data and program, Z-World recommends using a larger RAM during development. If the PK2200 has flash EPROM installed, the program will be compiled to flash EPROM instead of RAM.

EPROM

EPROMs offer a permanent storage option for programs and data. The PK2200 BIOS is factory installed in the EPROM. After an application is fully debugged and running, it can be compiled and stored in EPROM with an EPROM burner. Each time the PK2200 powers up, it will run the stored application.

Flash EPROM

Flash EPROM offers the benefits of both battery-backed RAM and standard EPROM. You can quickly change and download a program as if you were using RAM. Using flash EPROM frees up RAM for data storage rather than program storage. Flash EPROM does not depend upon the onboard battery to retain data, so a program is safe in the event that the battery is drained.



For more information on memory options or to place an order, contact your Z-World Sales Representative at (530) 757-3737.

Digital Inputs

The digital inputs can be used for a variety of applications such as detecting high-voltage and logic level digital signals, providing interrupts for time critical events, and high-speed counting.

Using the Digital Inputs

The digital inputs are supported in software by Dynamic C functions and virtual driver variables. There are several methods for reading the digital inputs. Some of the digital inputs have additional features listed below.

Interrupt Inputs

Inputs 11 and 12 can be used to generate level sensitive hardware interrupts on the PK2200 CPU. Interrupts can be used to signal events that need to be serviced in real-time.

High Speed DMA Counter

Two counters connected to digital inputs 13 and 14 are actually the CPU's DMA channel counters.

- The maximum counting speed is ≈ 1.5 MHz for 9.216 MHz PK2200 series controllers.
- The maximum counting speed is 3.0 MHz for 18.432 MHz PK2200 series controllers.

The following points summarize the counter's capabilities:

- The counter can measure the time at which a negative edge occurs with a precision of a few microseconds. A minimum time must occur between successive events to allow for interrupt processing.
- The counter can measure the width of a pulse by counting (up to 65,536) at a rate that varies from 300 Hz to 600 kHz, providing 16-bit accuracy.
- Count negative-going edges for up to two channels. The maximum count for high-speed counting (5 kHz and up) is 65,536. For low speeds, the maximum count is unlimited.

Function calls load the count-down value for the DMA channel and enable the DMA interrupt. Once a counter reaches zero, flags for the DMA channel are set to 1. DMA flags can be monitored by an application program.

Digital Outputs

Using the Digital Outputs

The digital outputs are supported in software by Dynamic C functions and virtual driver variables. There are several methods for writing to the digital outputs.

The digital outputs can be used for a wide variety of applications including the following:

- Driving solenoids, relays, motors and other inductive loads directly.
- Driving incandescent lamps, LEDs and resistive loads directly.
- Driving FETs, transistors, thyristors or solid state relays to increase the current or voltage output capability as well as providing a.c. drive capability.

Serial Communication

Dynamic C has serial communication support libraries. For the Z180 port z0 and Z180 port z1, use **AASC.LIB**, **Z0232.LIB**, and **Z1232.LIB**. For RS-232 expansion cards that interfaced through the PLCBus on the PK2200, use **EZIOPLC.LIB**.

Functional support for serial communication includes the following:

- Initialization of the serial ports
- Monitoring, and reading, a circular receive buffer
- Monitoring, and writing to, a circular transmit buffer
- An echo option
- CTS (clear to send) and RTS (request to send) control for RS-232.
- XMODEM protocol for downloading and uploading data
- A modem option



The PK2200 can be configured for either two RS-232 channels or one RS-232 and one RS-485. Z0 is RS-232 only and Z1 may be configured for RS-232 or RS-485. See Chapter 3 for information on configuring the serial communication channels.



Z180 Port Z0 is configured at the factory for RS-232 and Port Z1 is configured for RS-485.

Receive and Transmit Buffers

Serial communication is made easier with a background interrupt routine that updates receive and transmit buffers. Every time a port receives another character, the interrupt routine places it into the receive buffer. A program can read the data one character at a time or as a stream of characters terminated by a special character.

A program sends data by writing characters into the transmit buffer. If the serial port is not already transmitting, the write functions automatically initiate the transmission. Once the last character of the buffer is sent, the transmit interrupt is turned off. Data can be written one character at a time or as a stream of characters.

Echo Option

If the echo option is turned on during initialization of the serial port (with **Dinit_z0**, **Dinit_z1**, or **Dinit_uart**) any character received is automatically echoed back (transmitted out). This feature is ideal for use with a dumb terminal and also for checking the characters received.

CTS/RTS Control

Z180 port 0 is constrained by hardware to have the CTS (clear to send) pulled low by the RS-232 device with which it is communicating. An RS-232 expansion card, however, can enable or disable the effect of the CTS line. Z180 port 1 does not support the CTS / RTS lines.

If you choose the CTS/RTS option, the support software pulls the RTS (request to send) line high when the receive buffer has reached 80 percent of capacity. Thus, the transmitting device (if its CTS is enabled) stops transmitting. The RTS line is pulled low again when the received buffer has gone below 20 percent of capacity.

If the device with which the PK2200 is communicating does not support CTS and RTS, the CTS and RTS lines on the PK2200's side can be tied together to make communication possible.

XMODEM File Transfer

The PK2200 supports the XMODEM protocol for downloading and uploading data. Currently, the library supports downloading an array of data whose size is a multiple of 128 bytes.

Uploaded data is written to a specified area in RAM. The targeted area for writing should not conflict with the current resident program or data. During XMODEM transfers, character echo is automatically suspended.

Modem Communication

Modems and telephone lines allow serial communication across a great distance. If you choose the modem option, character streams that are read from the receive buffer are automatically scanned for modem commands. When a modem command is found, the software takes appropriate action. Normally, the communication package functions in **COMMAND** mode while waiting for valid modem commands or messages. Once a link is established, communication functions in **DATA** mode. However, the software continues to monitor the modem for a **NO_CARRIER** message.

The software assumes that modem commands are terminated with **CR**, which is carriage return (0x0D). The modem option is easiest to use when the user protocol also has **CR** as the terminating character. Otherwise, the software has to check for two different terminating characters. The user's terminating character cannot be any of the ASCII characters used in modem commands, nor can it be a line-feed character.

Library functions for the RS-232 port support communication with a Hayes Smart Modem or compatible. Note the following points:

- The CTS, RTS, and DTR lines of the modem are not used.
- If the modem used is not truly Hayes Smart Modem compatible, the user has to tie the CTS, RTS, and DTR lines on the modem side together. The CTS and RTS lines on the PK2200 side also have to be tied together.
- A NULL connection is required for the TX and RX lines.
- A commercial NULL modem will have its CTS and RTS lines tied together on both sides.

Figure 4-4 shows the correct modem to PK2200 wiring.

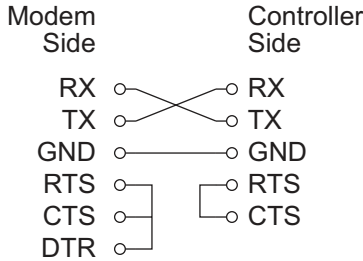

Figure 4-4. Null Modem Cable Connections

Following are descriptions for Z180 port 0 functions. Similar functions are available for the RS-232 (UART) expansion card. Please note the following substitutions:

For the RS-232 expansion card, substitute **uart** for **z0** in the function name.

For Z180 port 1, substitute **z1** for **z0** in the function name.

For example, the initialization routine for the Z180 port 0 is called **Dinit_z0()**. The equivalent function for the RS-232 expansion card is **Dinit_uart()**. The equivalent function for Z180 port 1 is **Dinit_z1()**.



Refer to Appendix F, "PLCBus," for details on software support for the RS-232 expansion card.

Interrupt Handling for Z180 Port 0

Normally, a serial interrupt service routine would be declared with the compiler directive:

```
#INT_VEC SERO_VEC routine
```

However, if you use the same serial port for Dynamic C programming, your program has to be downloaded first with Dynamic C before the address of the serial interrupt service routine is loaded into the interrupt vector table. That is, the service routine must be loaded at run-time.

The following function loads the address of the service function into the specified location in the interrupt vector table.

```
reload_vec (int vector, int(*serv_function)())
```

The `#INT_VEC` directive should not be used with this function. Once the service routine has taken over, you can't debug your program in Dynamic C.

If you communicate with a serial device other than the PC's Dynamic C programming port, your program has to make sure that the hardware is properly configured before sending any messages. For example, when using Z180 port 0 for serial communication with a modem, use the PK2200's keypad to trigger serial port initialization. Without this trigger, the modem may not properly communicate with the support software because the initialization routine also sends initialization commands to the modem.

When executable programs are generated either for EPROM or for downloading to RAM, there is no need for communication with Dynamic C. The compile-time directive `#INT_VEC` can then be used freely.

Remote Downloading

The PK2200 has the capability of remote downloading program code. This allows units to be reprogrammed in the field, eliminating the need to recall units for reprogramming or sending field service personnel to install new software. In order to use the remote download feature, the PK2200 must have a serial link to the remote PC, either a direct RS-232 link or a modem. The RS-232 connection is limited to several hundred feet. Modems allow communication over virtually unlimited distances.

If you plan to use the remote download feature, make sure that the PK2200 has enough memory to store future program revisions and data. Refer to Dynamic C Technical Reference Manual for a detailed description of the remote downloading procedure.

Developing an RS-485 Network

The two-wire RS-485 serial-communication port and Dynamic-C network software allow network development. Screw terminal strip J1 provides a half-duplex RS-485 interface.

The RS-485 signals are on screw terminals 18 and 19.

The PK2200 and/or other controllers can be linked together over several kilometers. When configuring a multi-drop network, use single twisted pair wires on all controllers to connect RS-485+ to RS-485+ and RS-485- to RS-485-. A diagram of a two-wire RS-485 network is shown in Figure 4-5.

Any Z-World controller can be a master or a slave. A network can have up to 255 slave controllers, but only one controller can be the master.

In a multidrop network, termination and bias resistors are required to minimize reflections (echoing) and to keep the network line active during an idle state. Only the first and last board on a multidrop RS-485 cable should have termination resistors. Therefore, when networking multiple boards via RS-485, remove termination resistors from all boards in the network, except for the first and last board of the network.

Only a single, solid conductor should be placed in a screw clamp terminal. Bare copper, particularly if exposed to the air for a long period before installation, can become oxidized. The oxide can cause a high resistance (~20 ohm) connection, especially if the clamping pressure is not sufficient. To avoid oxidation, use tinned wires or clean, shiny copper wire. If you are using multiple conductors or stranded wire, consider soldering the wire bundle or using a crimp connector to avoid a later loss of contact pressure to a spontaneous rearrangement of the wire bundle. Soldering may make the wire subject to fatigue failure at the junction with the solder if there is flexing or vibration.

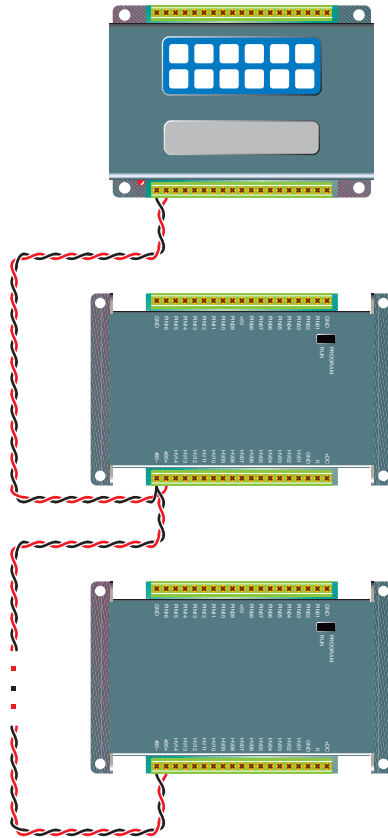

Figure 4-5. RS-485 Network

Keypad and LCD

The PK2200 Series supports operator I/O with a keypad and LCD. Two standard operator I/O configurations are available on PK2200 series controllers with enclosures:

- 2-row by 20-column character LCD module with a 2-row by 6-column keypad.
- 128-column by 64-row backlit graphic LCD module with a 4-row by 3-column keypad.

The character LCD module is also available with an LED backlighting option. The graphic LCD has electroluminescent backlighting installed as a standard feature.

Using the Keypad and Display

The PK2200 keypad and display are supported by a large number of software drivers. The keypad and display can be used for a variety of user interface applications including the following:

- User code or password entry
- System status display
- Multiple language/character-set displays
- Parameter monitoring and adjustment

PK2200 Keypads

Table 4-1 shows standard keypad configurations.

Table 4-1. Keypad Configurations

Model	Keypad
PK2200	2 x 6
PK2210	2 x 6
PK2220	None
PK2230	None
PK2240	4 x 3

Keypad Insert Templates

The keypads are designed to accept paper inserts. Inserts can be produced on regular paper using a laser printer, thus allowing quick and easy customization of keypad legends.

You can use the templates below for creating inserts. All dimensions are in inches. Inserts can be secured by taping the portion of the insert that extends beyond the keypad to the supporting bracket

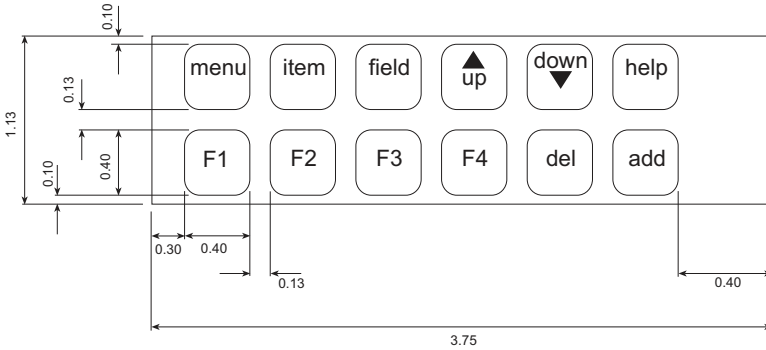

Figure 4-6. 2x6 Keypad Insert Template

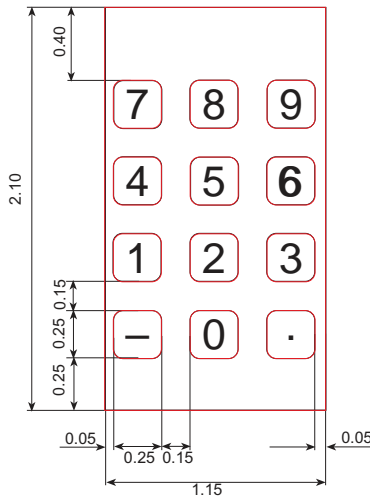

Figure 4-7. 3x4 Keypad Insert Template

Keypad Codes

The PK2200 keypads are supported by Dynamic C functions that return codes corresponding to the key pressed. The figures below show the codes for the 2x6 and 3x4 keypads used on the PK2200 Series controllers.

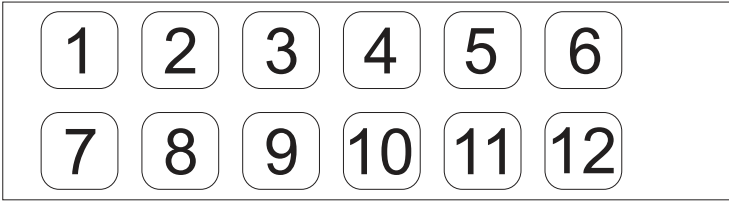

Figure 4-8. 2x6 Keypad Codes

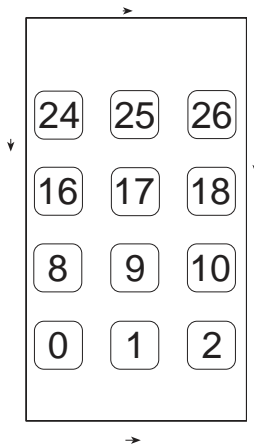

Figure 4-9. 3x4 Keypad Codes

PK2200 LCDs

The PK2200 Series LCDs are easy to use with Dynamic C software libraries. Shown below are the layouts for both the 2x20 character display and the 64x128 graphic display.

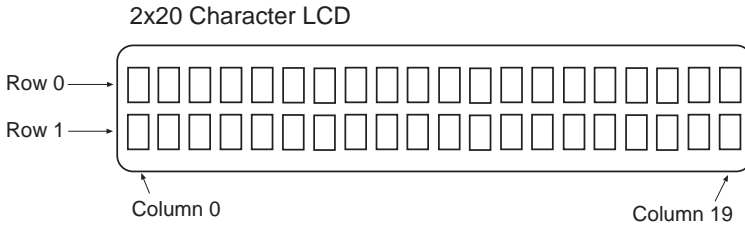

Figure 4-10. 2X20 Character LCD

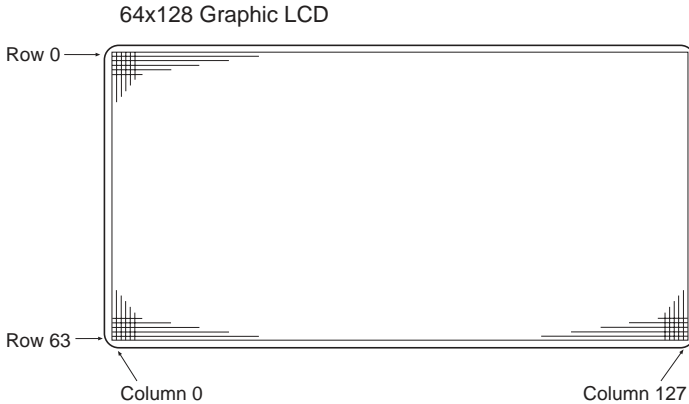

Figure 4-11. 64X128 Graphic LCD

Graphic LCD Status

Several Dynamic C library functions return the operating status of the LCD. The LCD status bits are shown in the following bitmap.

7	6	5	4	3	2	1	0
BUSY	0	ON/OFF	RESET	0	0	0	0
Most significant bit				Least significant bit			

BUSY - Reading a "1" indicates LCD is performing an operation. Reading a "0" indicates the LCD is ready to accept more data.

ON/OFF - When the ON/OFF bit is set (1) the display is on, any image on the screen will be visible. When the bit is reset (0) any images on the display will not be visible. The image is still in the display memory.

RESET - Resets the LCD module when low (0).

Bitmapped Graphics

Many of the Dynamic C functions that operate on the graphic LCD use bitmaps. These bitmaps represent the images on a section of the display. An individual dot, or pixel, is represented by one bit in the bitmap. If the pixel is on, the corresponding bit is set. If the pixel is off, the corresponding pixel is reset.

The image on the display is two-dimensional (width and height). The bitmap used to store that display information is a one-dimensional array. Two-dimensional images are stored in column major, byte aligned bitmap format.

Column major means that bits are stored in the bitmap column by column. The first pixel of the first column (row 0, column 0) of the image is stored in the first bit position in the bitmap. The second pixel of the first column is stored in the second bit position in the bitmap and so on. When the entire first column is stored in the bitmap, the process begins again with the second column and repeats until all columns of the image are stored.

Byte aligned means that a column data will end on a byte boundary. If a column has a number of bits that is not evenly divisible by eight, then the remaining bits of the last byte representing a column will be left unused. Image data from the next column will be stored starting in the next byte.

Blank



CHAPTER 5: SOFTWARE REFERENCE

Chapter 5 covers the software drivers used with the PK2200 series controllers.

Software Drivers

Drivers are functions that simplify accessing PK2200 hardware and I/O. For the following reasons, Z-World drivers make writing software easier:

- Provide commonly needed functionality.
- Eliminate the need to know all of the details of operation.
- Previously tested.
- Simplify source code by replacing multiple lines of code with one function call.



Refer to the *Dynamic C Technical Reference Manual* for more information on using drivers.

Real Time Clock (RTC)

The RTC keeps the date and the time of day with a resolution of one second. The worst case error is 50ppm (4.3 seconds) per day. Leap years and variances in the number of days in a month are automatically tracked.

The following structure holds the time and date:

```
struct tm {
    char tm_sec;      // 0-59
    char tm_min;      // 0-59
    char tm_hour;     // 0-23
    char tm_mday;     // 1-31
    char tm_mon;      // 1-12
    char tm_year;     // 0-150 (1900-2050)
    char tm_wday;     // 0-6 where 0 means Sunday
};
```

The following routines read and write to the real-time clock:

- **int tm_wr(struct tm *x)**

Sets the system time to the values in the structure pointed to by *x.

PARAMETER1: Pointer to the structure holding the system time information to be written.

RETURN VALUE: 0 if successful; -1 if clock failing or not installed.

- **int tm_rd(struct tm *t)**

Reads the current system time into the structure t.

PARAMETER1: Pointer to the structure used to store the system time.

RETURN VALUE: 0 if successful; -1 if clock failing or not installed.

EEPROM

The following functions provide access to the EEPROM. The EEPROM is generally used for storing system information, calibration information, or any data that does not need to change often.

- **`int ee_rd (int address)`**

Reads value from EEPROM at specified address.

PARAMETER1: The address to read from.

RETURN VALUE: EEPROM data (0-255) if successful; negative value if unable to read EEPROM.

- **`int ee_wr (int address, char data)`**

Writes value to EEPROM at specified address.

PARAMETER1: The address to write to.

RETURN VALUE: Returns 0 if write is successful, negative value if unsuccessful.

Digital Inputs and Outputs

- **DIGIN1, DIGIN2, . . . , DIGIN16**

The virtual driver variables DIGIN1, DIGIN2, ... DIGIN16 represent the state of the digital inputs. These variables take the value 1 if the input is high and 0 if the input is low. The value is changed only if the new value remains the same for 2 ticks (25 to 50 milliseconds) of the virtual driver.

- **void VIOInit();**

VIOInit is a dummy function used as a host for the **GLOBAL_INIT** of the virtual I/O variables. Virtual inputs are read and virtual outputs are written out whenever the function **VIODrvr()** is called. Inputs are DIGIN1 to DIGIN16. Outputs are OUT1 to OUT16. The DIGIN values have to be the same for two successive reads to be valid.

RETURN VALUE: None.

- **void VIODrvr();**

Updates the virtual inputs DIGIN1 to DIGIN16. The virtual outputs OUT1 to OUT14 are send out to corresponding output ports.

RETURN VALUE: None.

Digital Input Drivers

There are several methods for reading digital inputs and setting digital outputs on the PK2200. Below is a listing of drivers for the digital inputs and outputs, including the high-speed DMA counters.

- **int up_digin(int channel)**

Read the value at the specified digital input channel (1–16).

RETURN VALUE: The function returns 1 when the channel is high and 0 when the channel is low.

- **unsigned inport(unsigned port)**

Reads value from I/O port.

PARAMETER: **port** is the I/O port to be read.

RETURN VALUE: Value from I/O port.

You can read multiple PK2200 digital inputs simultaneously using the **inport()** function.

DIGBANK1 is the address (0x180) of the first eight digital inputs DIN1 through DIN8. Bit zero represents the state of DIN1, bit one is DIN2, etc. **DIGBANK2** is the address (0x181) of the second eight digital inputs DIN9 through DIN16. Bit zero represents the state of DIN9, bit one is DIN10, etc.

The lower eight bits returned by the `inport()` function represent the status of the digital inputs. Bits which are set (1) represent inputs which are high. Bits which are reset (0) correspond to inputs which are low.

Example:

```
lowDIBank = inport( DIGBANK1 );
highDIBank = inport( DIGBANK2 );
```

- **void DMA0Count (unsigned int count)**

Loads the DMA channel 0 with the `count` value and enables the DMA channel 0 interrupt.

The function sets the flag `_DMAFLAG0` to zero. When `count` negative edges have been detected, the channel causes an interrupt, and the interrupt service routine sets the flag `_DMAFLAG0` to 1. A program can monitor `_DMAFLAG0` to determine if the number of counts has occurred.

PARAMETER: `count` is the number of pulses to count.

RETURN VALUE: None

- **void DMA1Count (unsigned int count)**

Loads DMA channel 1 with the `count` value and enables the DMA channel 1 interrupt.

The function sets the flag `_DMAFLAG1` to zero. When `count` negative edges have been detected, the channel causes an interrupt, and the interrupt service routine sets the flag `_DMAFLAG1` to 1. A program can monitor `_DMAFLAG1` to determine if the number of counts has occurred.

PARAMETER: `count` is the number of pulses to count

RETURN VALUE: None

- **unsigned int DMASnapShot (byte channel, unsigned int *count)**

Reads the number of pulses that a DMA channel has counted. A DMA counter is initialized with one of the two preceding functions.

PARAMETERS: `channel` is the DMA channel (0 or 1)

`*count` is a pointer to variable holding the pulse count.

RETURN VALUE: 0, if pulse train is too fast to have a snap shot taken; 1, if a snap shot is obtained and valid data is in `*count`.



Even if a program is unable to read the counts, DMA interrupts still occur when the DMA channel counts down from its loaded value.

Digital Output Drivers

Following are the digital output drivers for the PK2200:

- **int up_setout(int channel, int value)**

Sets the state of digital output.

PARAMETER1: The digital output channel to set.

PARAMETER2: The state to set. 1 (active) or 0 (inactive).

RETURN VALUE: None.

Pass **channel** (1–14) and **value**: 0 for OFF, 1 for ON.

- **OUT1, OUT2, ..., OUT14**

Set the virtual driver variables OUT1, OUT2, OUT3, ... OUT13, OUT14 to a value of 0 to turn off the output, or 1 to turn on the output.

- **void outport(unsigned port, unsigned value);**

Writes value to I/O port.

PARAMETER1: The output port.

PARAMETER2: The value to be written.

RETURN VALUE: None

The addresses DRV1 - DRV14 are the port addresses for the digital outputs. Writing 0 to any of these ports will turn the output OFF. To turn ON digital outputs 1 through 8 write 0x20 to the corresponding port. For digital outputs 9 through 14 write 0x40 to turn the output ON.



The digital outputs are individually addressed and must be set one at a time.

LCD and Keypad

The following functions provide routines for writing to the LCD and reading the keypad.

Include the following directives in your program if using the PK2240.

```
#use wintek.lib
#use kp.lib
```

The following directives provide information to the compiler about the graphic LCD and keypad on the PK2240.

- **void lc_init_keypad()**
Initializes timer1, keypad driver, and variables, and, if used, the real-time kernel.
RETURN VALUE: None.
- **int lc_kxget (byte mode)**
Fetches the key value from the FIFO keypad buffers. If mode = 0, value is removed from the buffer; otherwise, value remains in the buffer.
RETURN VALUE: Key value or -1, if no key is available.



The “Keypad and LCD” section in Chapter 4 describes key values.

- **void lc_kxinit()**
Initialize the keypad driver and accessory variables. If virtual watchdogs are defined the virtual watchdogs are initialized.
RETURN VALUE: None.
- **void lc_setbeep (int count)**
Sounds the beeper for the number of 1280 Hz cycles specified by **count**.
RETURN VALUE: None.
- **up_beep (int milliseconds)**
Sets beeper on for specified number of milliseconds. Scaling of the count passed is dependent on the periodic routines that calls **lc_beepscan**. If **BeepScale** is undefined, it is defaulted to 0.04.
RETURN VALUE: None.
- **void lc_char (char ch)**
Sends a character to the LCD. The function waits for the LCD to become free before sending the character.
RETURN VALUE: None

- **int lc_cmd (int cmd)**
 Waits for LCD busy flag to clear, then sends `cmd` to LCD command register.
 RETURN VALUE: 0, if successful in writing to the LCD; else -1, if timeout
- **void lc_ctrl (byte cmd)**
 Write a control `cmd` to the LCD.
 RETURN VALUE: None.
- **void lc_init()**
 Initializes the LCD. The display is turned on, cleared, and the cursor (now in the top left character position) blinks.
 RETURN VALUE: None
- **void lc_nl()**
 Performs a new line function on the LCD.
 RETURN VALUE: None
- **void lc_pos (int line, int column)**
 Positions the cursor at the line designated by `line` and column designated by `column` on the LCD.
 RETURN VALUE: None
- **void lc_printf (char* fmt, ...)**
 Performs a `printf` to the LCD. The function arguments are specified as they are for the standard `printf`.
 RETURN VALUE: None
- **int lc_wait()**
 Waits for LCD busy flag to clear. Caution, doesn't time out.
 RETURN VALUE: 0, when LCD busy flag has cleared; else -1, if timeout after ten tries.
- **void glSetBrushType(int type)**
 Sets the brush type for all following graphics operations in this library. It controls how pixels are drawn on the screen with respect to existing pixels.
 PARAMETER1: This is the type of the brush. Possible values are `GL_SET` for forcing pixels on, `GL_CLEAR` for forcing pixels off, `GL_XOR` for toggling the existing pixels and `GL_BLOCK` to overwrite the entire memory location corresponding to the pixel.
 RETURN VALUE: None.

- **int glInit()**
Initializes the LCD module (software and hardware).
RETURN VALUE: returns the status of the LCD. If the initialization was successful, this function returns 0. Otherwise, the returned value indicates the LCD status.
- **int glBlankScreen()**
Blanks the screen of the LCD.
RETURN VALUE: The returned value indicates the status of the LCD after the operation.
- **int glPlotDot(int x, int y)**
Plots one pixel on the screen at coordinate (x,y).
PARAMETER1: the x coordinate of the pixel to be drawn.
PARAMETER2: the y coordinate of the pixel to be drawn.
RETURN VALUE: Status of the LCD after the operation.
- **void glPlotLine(int x1, int y1, int x2, int y2)**
Plots a line on the LCD.
PARAMETER1: x coordinate of first endpoint.
PARAMETER2: y coordinate of first endpoint.
PARAMETER3: x coordinate of second endpoint.
PARAMETER4: y coordinate of second endpoint.
RETURN VALUE: None.
- **void glPutBitmap(int x, int y, int bmWidth, int bmHeight, char *bm)**
Displays a bitmap stored in root memory on the LCD. For bitmaps defined in xmem memory, use **glXPutBitmap**.
PARAMETER1: x coordinate of the bitmap (left edge).
PARAMETER2: y coordinate of the bitmap (top edge).
PARAMETER3: width of the bitmap.
PARAMETER4: height of the bitmap.
PARAMETER5: pointer to the bitmap.
RETURN VALUE: None.

- void glXPutBitmap(int x, int y, int bmWidth, int bmHeight, unsigned long bmpPtr)**

Displays a bitmap stored in `xmem` on the LCD. For bitmaps stored in root memory, use `glPutBitmap`.

PARAMETER1: x coordinate of the bitmap (left edge).

PARAMETER2: y coordinate of the bitmap (top edge).

PARAMETER3: width of the bitmap.

PARAMETER4: height of the bitmap.

PARAMETER5: pointer to the bitmap.

RETURN VALUE: None.
- void glGetBitmap(int x, int y, int bmWidth, int bmHeight, char *bm)**

Gets a bitmap from the LCD.

PARAMETER1: x coordinate of the bitmap (left edge).

PARAMETER2: y coordinate of the bitmap (top edge).

PARAMETER3: width of the bitmap.

PARAMETER4: height of the bitmap.

PARAMETER5: pointer to the bitmap.

RETURN VALUE: None.
- void glFontInit(struct _fontInfo *pInfo, char pixWidth, char pixHeight, unsigned startChar, unsigned endChar, char bitmapBuffer)**

Initializes a font descriptor with the bitmap defined in the `root` memory. For fonts with bitmaps defined in `xmem`, use `glXFontInit`.

PARAMETER1: pointer to the font descriptor to be initialized.

PARAMETER2: width of each font item (must be uniform for all items).

PARAMETER3: height of each font item (must be uniform for all items).

PARAMETER4: offset to the first useable item (useful for fonts for ASCII or other fonts with an offset).

PARAMETER5: index of the last useable font item.

PARAMETER6: pointer to a linear array of font bitmap.

RETURN VALUE: None.

- **void glXFontInit(struct _fontInfo *pInfo, char pixWidth, char pixHeight, unsigned startChar, unsigned endChar, unsigned long xmemBuffer)**

Initializes a font descriptor that has the bitmap defined in **xmem**. For bitmaps defined in root memory, use **glFontInit**.

PARAMETER1: pointer to the font descriptor to be initialized.

PARAMETER2: width of each font item (must be uniform for all items).

PARAMETER3: height of each font item (must be uniform for all items).

PARAMETER4: offset to the first useable item (useful for fonts for ASCII or other fonts with an offset).

PARAMETER5: index of the last useable font item.

PARAMETER6: pointer to a linear array of font bitmap.

RETURN VALUE: None.

- **void glPutFont(int x, int y, struct fontInfo *pInfo, unsigned code)**

Puts an entry from the font table to the LCD.

PARAMETER1: x-coordinate of the entry (left edge).

PARAMETER2: y-coordinate of the entry (top edge).

PARAMETER3: pointer to the font descriptor that describes the font table to be indexed.

PARAMETER4: code (offset) in the font table that indexes the bitmap to display.

RETURN VALUE: None.

- **void glVPrintf(int x, int y, struct fontInfo *pInfo, char *fmt, void *firstArg)**

Prints a formatted string on the LCD screen, similar to **vprintf**.

PARAMETER1: x coordinate of the text (left edge).

PARAMETER2: y coordinate of the text (top edge).

PARAMETER3: pointer to font descriptor that describes the font used for printing the text.

PARAMETER4: pointer to the string that describes the format.

PARAMETER5: pointer to the first argument to instigate the format string.

RETURN VALUE: None.

- **void glPrintf(int x, int y, struct _fontInfo *pInfo, char *fmt, ...)**

Prints a formatted string (much like printf) on the LCD screen.

PARAMETER1: x coordinate of the text (left edge).

PARAMETER2: y coordinate of the text (top edge).

PARAMETER3: pointer to the font descriptor used for printing on the LCD screen.

PARAMETER4: pointer to the format string

RETURN VALUE: None.

- **void glPlotCircle(int xc, int yc, int rad)**

Draws a circle on the LCD.

PARAMETER1: x coordinate of the center.

PARAMETER2: y coordinate of the center.

PARAMETER3: radius of the circle.

RETURN VALUE: None.

- **int wtDisplaySw(int onOff)**

Switches the display on and off.

PARAMETER1: If this parameter is 1, the display is turned on. If this parameter is 0, the display is turned off.

RETURN VALUE: Status of the LCD after the operation.

- **void kdiELSw(int value)**

Switches the EL backlight of the LCD.

PARAMETER1: 1 to turn the backlight on, 0 to turn the backlight off.

RETURN VALUE: None.

- **void kdiSetContrast(unsigned content)**

Sets the contrast control to **content**.

PARAMETER1: Specifies the contrast (the higher the value, the higher the contrast).

RETURN VALUE: None

- **void kpInit(int (*changeFn) ())**

Initializes the **kp** module. This function should be called before other functions of this module are called.

PARAMETER1: This is a pointer to a function that will be called when the driver detects a change (when **kpScanState** is called). Two arguments are passed to the call-back function. The first argument is a pointer to an array that indicates the current state of the keypad. The second pointer is a pointer to an array that indicates what keypad positions are changed and detected by **kpScanState**. The byte offset in the array represents the line pulled high (row number), and the bits in a byte represents the positions (column number) read back.

RETURN VALUE: None

- **int kpScanState ()**

Scans the keypad and detect any changes to the keypad status. Returns non-zero if there is any change. If **kpInit** is called with a non-NULL function pointer, that function will be called with the state of the keypad. This function should be called periodically to scan for keypad activities.

RETURN VALUE: 0 if there is no change to the keypad, non-zero if there is any change to the keypad.

- **int kpDefStChgFn(char *curState, char *changed)**

This is the default state change function for the default get key function **kpDefGetKey**. This function is called back by **kpScanState** when there is a change in the keypad state. If the current key is not read by **kpDefGetKey**, the new key pressed will not be registered.

PARAMETER1: Points to an array that reflects the current state of the keypad (bitmapped, 1 indicates key is not currently pressed).

PARAMETER2: Points to an array that reflects the CHANGE of keypad state from the previous scan. (bitmapped, 1 indicates there was a change).

RETURN VALUE: -1 if no key is pressed. Otherwise it returns the normalized key number. The normalized key number is $8 * \text{row} + \text{col} + \text{edge} * 256$. Edge is 1 if the key is released, and 0 if the key is pressed.

- **int kpDefGetKey()**

This is the default get key function. This function returns the key previously pressed (i.e., from the one-keypress buffer). The key pressed is actually interpreted by **kpDefStChgFn**, which is called back by **kpScanState**. The function **kpDefInit** should be used to initialize the module.

RETURN VALUE: -1 if no key is pressed. Otherwise it returns the normalized key number. The normalized key number is $8 * \text{row} + \text{col} + \text{edge} * 256$. Edge is 1 if the key is released, and 0 if the key is pressed.

- **void kpDefInit()**

Initializes the module to use the default state change function to interpret key presses when **kpScanState** is called. Use **kpDefGetKey** to get the code of the last key pressed.

RETURN VALUE: NA.

Sample Programs

The sample programs listed in Table 5-1 are specific to the PK2200. They can be found in the **SAMPLES\CPLC** directory.

Table 5-1. PK2200 Sample Programs

Program	Description
5KEYCODE.C	Code-driven sample program for the five-key system.
5KEYDEMO.C	Uses a code-driven five-key system and the RT-kbyte for I/O monitor and control.
5KEYLAD.C	Combines 5KEYCODE.C and LADDERC.C .
5KEYLINK.C	Linked-list sample program for the five-key system.
5KEYSCAN.C	Combines 5KEYCODE.C and SCANBLK.C .
CDEMO_RT.C	Demonstrate the use of the real-time kernel.
DIGDEMO.C	Use the keypad to select which digital input channel to monitor.
DIGVDVR.C	Similar to DIGDEMO.C but uses the virtual driver to monitor the state of the input.
DMACOUNT.C	Demonstrates the use of the high speed counters.

continued...

Table 5-1. PK2200 Sample Programs (concluded)

Program	Description
LADDERC.C	Use ladder C for I/O control.
LCGRAM.C	Illustrates use of the LCD character generator.
OUTDEMO.C	Use keypad to toggle the state of the digital outputs.
OUTVDVR.C	Similar to OUTDEMO.C , but uses the virtual driver to change the state of the output.
PRT0DEMO.C	Use TIMER0 for timer interrupt .
READIO.C	Read and toggle the I/Os through STDIN . The I/Os are driven by function calls.
READKEY.C	Read the keypad and write to the LCD and to the STDIO window.
SCANBLK.C	Use function blocks for I/O control.
UREADIO.C	Read and toggle the I/Os through STDIN . The I/Os are driven by the virtual driver.
VWDOG.C	Illustrates the use of the virtual watchdogs and of KEYREQUEST

Communication Sample Programs

The sample communication programs listed in Table 5-2 are located in the **SAMPLES\NETWORK** directory.

Table 5-2. Sample Communication Programs

Program	Description
CSREMOTE.C	Slave version of CZ0REM.C , that includes most capabilities of CZ0REM.C . Master-to-slave communication is via opto22 9th-bit binary protocol.
CUARTREM.C	Same as CZ0REM.C but uses XP8700 expansion card.

continued...

Table 5-2. Sample Communication Programs (concluded)

Program	Description
CZOREM.C	More elaborate sample of serial communication between board and PC dumb terminal. Includes modem communication, data monitoring, time and date setup, memory read and write, data logging, XMODEM download of the data log, XMODEM upload of binary file for remote downloading. Also supports master-to-slave communication. (Slave has to be running the program CSREMOTE.C .)
RS232.C	RS-232 communication with a PC dumb terminal, with or without modem. Also, master-to-slave communication with another board running RS-485.C.
RS485.C	Slave program to communicate with the master running RS-232.C.
UART232.C	RS-232 communication through an RS-232 expansion card with the PK2200.
Z1232.C	An RS-232 program for Z180 port 1.

PK2240 Sample Programs

The sample programs listed in Table 5-3 are specific to the PK2240 and are located in the **SAMPLES\PK224X** directory. These programs illustrate the use of the graphic LCD and keypad.

Table 5-3. PK2240 Sample Programs

Program	Description
GLPRINTF.C	Demonstrates the glprintf function and shows how to print text on the graphics display.
KPDEFLT.C	Demonstrates key scanning techniques using functions in the KP library.



APPENDIX A: TROUBLESHOOTING

Appendix A provides procedures for troubleshooting system hardware and software.

Out of the Box

Check the items mentioned in this section before starting development.

- Verify that the PK2200 runs in standalone mode before connecting any expansion boards or I/O devices.
- Verify that the entire host system has good, low-impedance, separate grounds for analog and digital signals. Often the controller is connected between the host PC and another device. Any differences in ground potential from unit to unit can cause serious problems that are hard to diagnose.
- Do not connect analog ground to digital ground anywhere.
- Double-check the connecting ribbon cables to ensure that all wires go to the correct headers.
- Verify that the host PC's COM port works by connecting a good serial device to the COM port. Remember that COM1/COM3 and COM2/COM4 share interrupts on a PC. User shells and mouse drivers, in particular, often interfere with proper COM port operation. For example, a mouse running on COM1 can preclude running Dynamic C on COM3.
- Use the supplied Z-World power supply. If another power supply must be used, verify that it has enough capacity and filtering to support the PK2200.
- Use the supplied Z-World cables. The most common fault of user-made cables is failure to properly assert CTS at the RS-232 port of the controller. Without CTSs being asserted, the controller's RS-232 port will not transmit. Assert CTS by either connecting the RTS signal of the PC's COM port or looping back the PK2200's RTS.
- Experiment with each peripheral device connected to the controller to determine how it appears to the controller when powered up, powered down, and/or when its connecting wiring is open or shorted.
- If a DB9 connector or an RJ-12 connector is wired up to a 10-pin connector, carefully check the connections. These wires *do not* run pin-for-pin.

Note: Telephone company wiring does not follow a standardized color code.

Dynamic C Will Not Start

In most situations, when Dynamic C will not start, an error message announcing a communication failure will be displayed. Following is a list of situations causing an error message and possible resolutions.

- *Wrong Baud Rate* — In rare cases, the baud rate has to be changed when using the Serial Interface Board for development.
- *Wrong Communication Mode* — Both sides must be talking RS-232.
- *Wrong COM Port* — A PC generally has two serial ports, COM1 and COM2. Specify the one being used in the Dynamic C “Target Setup” menu. Use trial and error, if necessary.
- *Wrong Operating Mode* — Communication with Dynamic C will be lost if the controller’s jumper is set for standalone operation. Reconfigure the board for programming mode.
- *Wrong Memory Size* — Jumpered pins on JP2 specify the EPROM size.

If all else fails, connect the serial cable to the controller after power up. If the PC’s RS-232 port supplies a large current (most commonly on portable and industrial PCs), some RS-232 level converter ICs go into a nondestructive latch-up. Connect the RS-232 cable after power up to eliminate this problem.

Dynamic C Loses Serial Link

If the program disables interrupts for a period greater than 50 milliseconds, Dynamic C will lose its serial link with the application program. Make sure that interrupts are not disabled for a period greater than 50 milliseconds.

PK2200 Repeatedly Resets

The PK2200 resets every 1.0 seconds if the watchdog timer is not “hit.” If a program does not “hit” the watchdog timer, then the program will have trouble running in standalone mode. To “hit” the watchdog, make a call to the Dynamic C library function **hitwd**.

Common Programming Errors

- Values for constants or variables out of range. Table A-1 lists acceptable ranges for variables and constants.

Table A-1. Constant and Variable Ranges

Type	Range
int	-32,768 (-2^{15}) to +32,767 ($2^{15}-1$)
long int	-2,147,483,648 (-2^{31}) to +2147483647 ($2^{31}-1$)
float	1.18×10^{-38} to 3.40×10^{38}
char	0 to 255

- Mismatched “types.” For example, the literal constant **3293** is of type **int** (16-bit integer). However, the literal constant **3293.0** is of type **float**. Although Dynamic C can handle some type mismatches, avoiding type mismatches is the best practice.
- Counting up from, or down to, one instead of zero. In software, ordinal series often begin or terminate with zero, not one.
- Confusing a function’s definition with an instance of its use in a listing.
- Not ending statements with semicolons.
- Not inserting commas as required in functions’ parameter lists.
- Leaving out ASCII space character between characters forming a different legal, but unwanted operator.
- Confusing similar-looking operators such as **&&** with **&**, **==** with **=**, and **//** with **/**.
- Inadvertently inserting ASCII nonprinting characters into a source-code file.



APPENDIX B: SPECIFICATIONS

Appendix B provides comprehensive PK2200 physical, electronic, and environmental specifications.

General Specifications

Table B-1 lists the electrical, mechanical, and environmental specifications for the PK2200.

Table B-1. PK2200 General Specifications

Parameter	Specification
Operating Temp	-40° C to 70° C
Humidity	5% to 95%, noncondensing
Input Voltage	9 V to 24 V DC
Digital Inputs	16 protected, -20 V to +24 V DC
Digital Outputs	14 high-current sinking (500 mA max.) or sourcing (250 mA max.).
Processor	Z80180
Clock	9.216 MHz or 18.432 MHz.
SRAM	32K standard, 512K maximum
EEPROM	512 bytes
Flash EPROM	Up to 256K
Serial ports	2 RS-232 or 1 RS-232 with RTS/CTS and 1 RS-485
Serial rate	Up to 115,200 bps
Watchdog/supervisor	Yes
Time/date clock	Yes
Backup battery	Yes, internal 3 V DC lithium ion

Hardware Mechanical Dimensions

Top view for models PK2200 and PK2210.

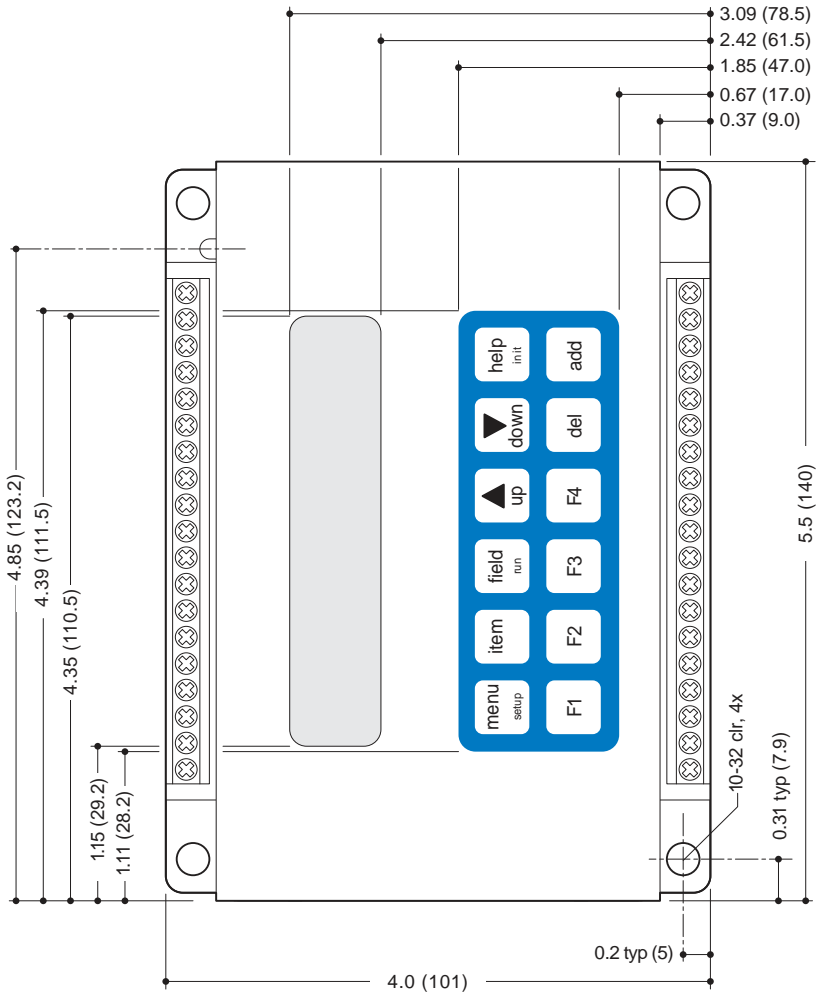

Figure B-1. Top View PK2200 and PK2210

Top view for model PK2240.

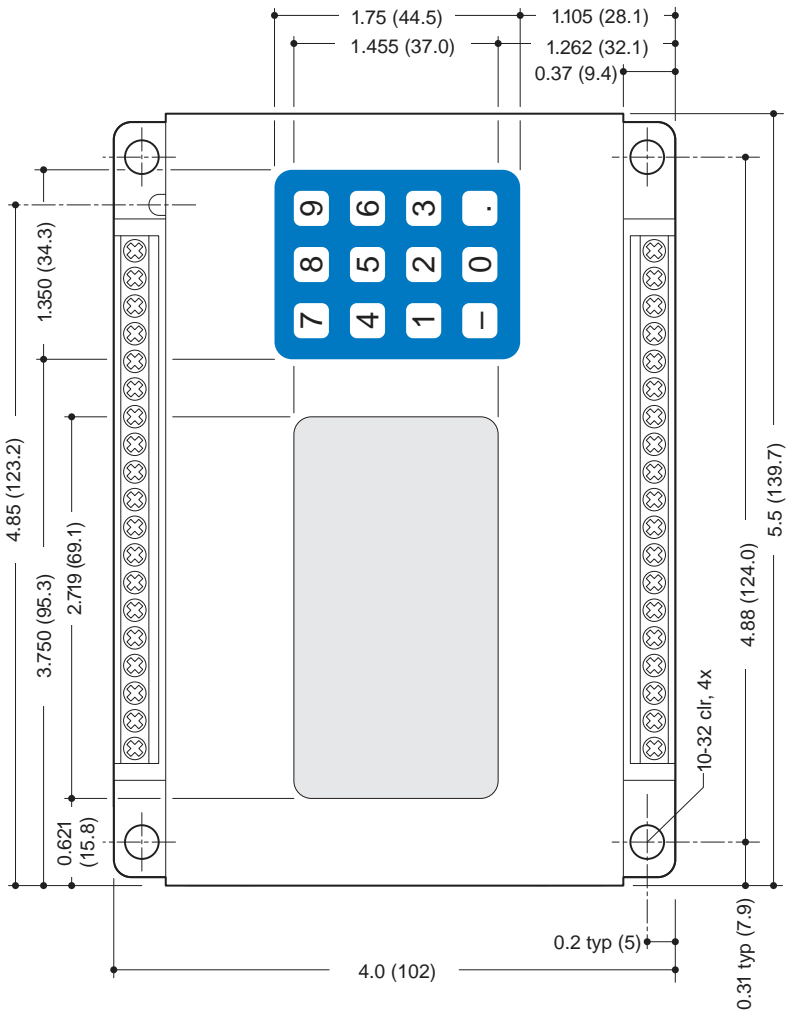

Figure B-2. Top View PK2240

End view for models PK2200, PK2210 and PK2240.

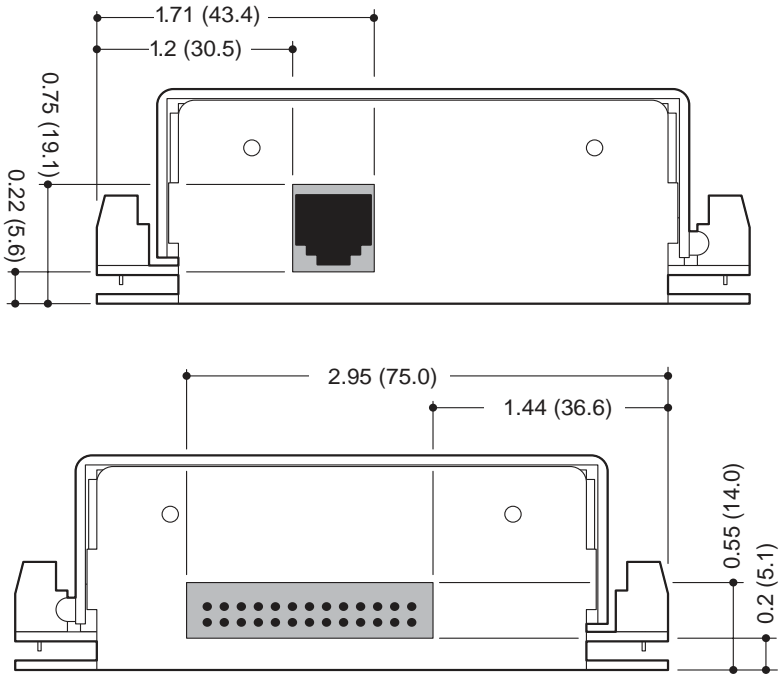

Figure B-3. End View PK2200, PK2210, and PK2240

The board dimensions are 4.0"×5.32" overall. The centers of the mounting holes are inset (0.220", 0.770") from the corners of the board. They are 2.46" and 4.88" on center. Mounting holes are 0.160" in diameter.

Top view of models PK2220 and PK2230.

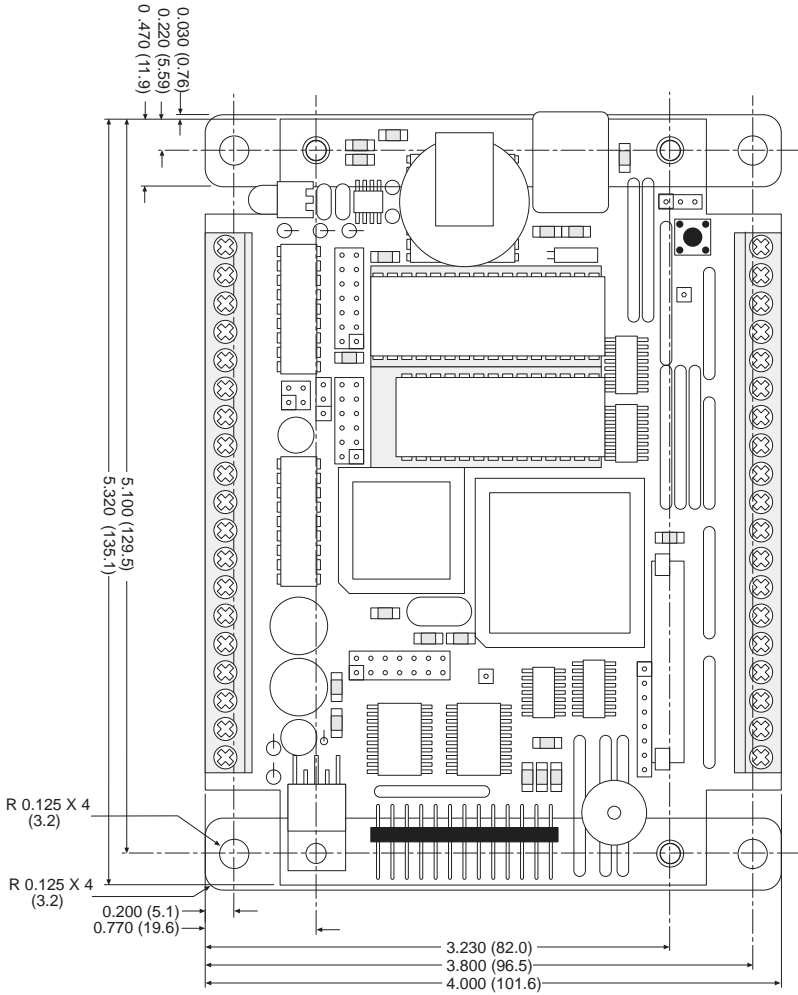

Figure B-4. Top View PK2220 and PK2230

High Voltage Driver Specifications

Table B-2. Sinking Driver Specifications

Parameter	Absolute Maximum Rating at 25°C
Output Voltage	50 V DC
Output Current	500 mA
Power Dissipation (Change)	1.0 W
Power Dissipation (Package)	2.25 W
C-E Saturation Voltage (max.)	1.3 V
Derating Factor	18.18 mW/°C above 25°C

Table B-3. Sourcing Driver Specifications

Parameter	Absolute Maximum Rating
Output Voltage	30V DC
Output Current	250 mA
Power Dissipation (Chan)	1.0 W
Power Dissipation (Package)	2.2 W
C-E Saturation Voltage (maximum)	1.2 V
Derating Factor	18 mW/°C above 25°C

Environmental Temperature Constraints

No special precautions are necessary over the range of 0°C to 50°C (32°F to 122°F). For operation at temperatures below 0°C, the PK2200 should be equipped with a low temperature LCD that is specified for operation down to -20°C. The heating effect of the power dissipated by the unit may be sufficient to keep the temperature above 0°C, depending on the enclosure's insulating capability. The LCD storage temperature is 20°C lower than its operating temperature, which may protect the LCD in case the power should fail, thus removing the heat source. The LCD unit is specified for a maximum operating temperature of 50°C. Except for the LCD, which fades at higher temperatures, the PK2200 operates at 60°C or more without problem.



External loads and expansion cards can increase power consumption.

Connectors

Only a single, solid conductor should be placed in a screw clamp terminal. Bare copper, particularly if exposed to the air for a long period before installation, can become oxidized. The oxide can cause a high resistance (~20 Ω) connection, especially if the clamping pressure is not sufficient. To avoid this, use tinned wires or clean, shiny copper wire. If you are using multiple conductors or stranded wire, consider soldering the wire bundle or using a crimp connector to avoid a loss of contact pressure to a spontaneous rearrangement of the wire bundle at a latter time. Soldering may make the wire subject to fatigue failure at the junction with the solder if there is flexing or vibration.

Header Locations and Jumper Settings

Figure B-5 illustrates the location of the headers on the PK2200. Table B-4 lists each header and explains possible pin connections.

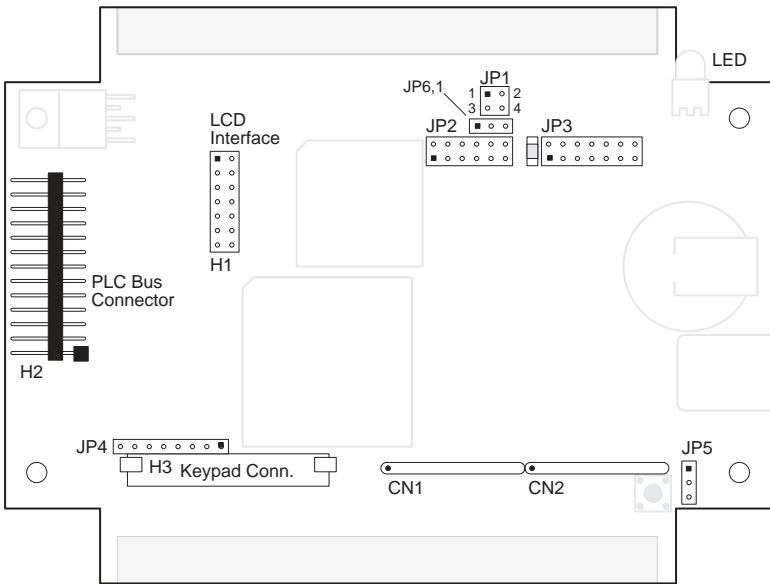

Figure B-5 PK2200 Jumpers and Headers

Table B-4. Headers and Jumper Settings

Header	Pins	Description
JP1	1-3, 2-4	Sink/source control. The drivers will be damaged if the jumpers are set incorrectly.
	1-2, 3-4	Connect for the ULN2803 sinking drivers (default). Connect for the UDN2985A sourcing drivers.
JP2	1-3, 2-4	<u>EPROM</u> <u>flash EPROM</u> 32K
	3-5, 2-4	64K
	3-5, 4-6	128K 128K
	3-5, 4-6	256K 256K
	3-5, 4-6	512K
		<u>Input pullup/pulldown resistors</u> 7-9 Inputs 1-4 and 9-12 are pulled up. 9-11 Inputs 1-4 and 9-12 are pulled down. 8-10 Inputs 5-8 and 13-16 are pulled up. 10-12 Inputs 5-8 and 13-16 are pulled down.
JP3	1-2	<u>Miscellaneous</u> Enables the watchdog timer (default).
	3-4	Allows the CTS line to reset the board.
	5-6, 9-11	<u>Serial Communication</u> One 5-wire RS-232 channel (Z180 Port 0) with RTS/CTS
	7-8	One 3-wire RS-232 One RS-485 channel (Port 1)
	5-6, 7-8, 9-11	One 5-wire RS-232 One RS-485
	5-7, 11-13	Two 3-wire RS-232 channels
JP4	10-12	<u>SRAM sizing</u> 32K or 128K SRAM (default)
	12-14	512K SRAM
JP4	7-8	Readable jumper equivalent to mode-setting keypad keys. JP4 overrides the keypad if jumper installed.
	6-7	Places unit in program mode at 19,200 bps.
	2-3	Runs the program.
	4-5	Places unit in program mode at 28,800 bps. indicates to Dynamic C that watchdog timer is enabled. Connect when JP3:1-2 is installed.
JP5	1-2	Write protect the EEPROM.
	2-3	Write-enable the EEPROM.
JP6	1-2	EPROM
	2-3	flash EPROM



Blank



APPENDIX C: POWER MANAGEMENT

Appendix C provides information about power management and hardware and software specific to power management on the PK2200.

Power Failure Detection Circuitry

Figure C-1 shows the power failure detection circuitry of the PK2200.

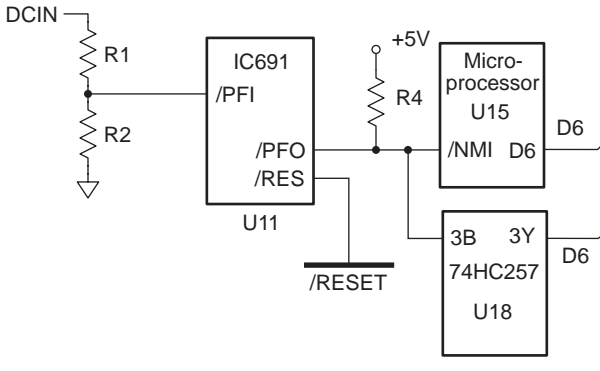

Figure C-1. PK2200 Power-Fail Circuit

Power Failure Sequence of Events

The following events occur as the input power fails:

1. The 691 power-management IC first triggers a power-failure /NMI (non-maskable interrupt) when the unregulated DC input voltage falls below approximately 7.9 V (as determined by the voltage divider R1/R2).
2. At some point, the raw input voltage level will not exceed the required regulated voltage level by the regulator's dropout voltage whereupon the regulated output begins to droop.
3. The 691 next triggers a system reset when the regulated +5 V supply falls below ~ 4.75 V, allowing your power-failure routine the "holdup" interval, t_{HP} , to store your important state data.
4. The 691 forces the chip enable of the SRAM high (standby mode).
5. The time/date clock and SRAM switches to the lithium backup battery when the regulated voltage falls below the battery voltage of approximately 3 V.
6. The 691 keeps the reset asserted until the regulated voltage drops below 1 V.
7. At this point the 691 ceases operating. By this time, the portion of the circuitry not battery-backed has long since ceased functioning.

The ratio of your power supply's output capacitor's value to your circuit's current draw determines the actual duration of the holdup-time interval, t_H .

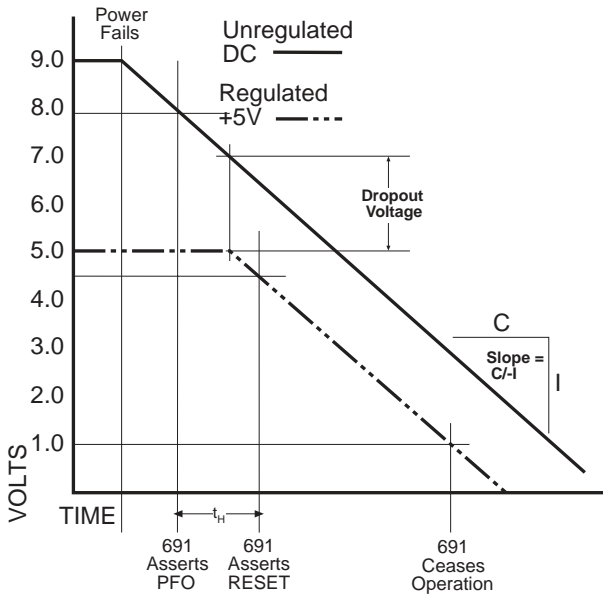

Figure C-2. Power Fail Sequence of Events

This setup can fail when multiple power fluctuations happen rapidly — a common occurrence in the real world. If the PK2200's Z180 processor receives multiple /NMIs, it overwrites an internal register, making a correct return from the first /NMI impossible. Also, depending on the number of fluctuations of the raw DC input (and hence, the number of stacked /NMIs), the processor's stack could overflow, corrupting your program's code or data.

When the Z180 senses an NMI, it saves the program counter (PC) on its processor stack. It copies the maskable interrupt flag, IEF1, to IEF2 and zeroes IEF1. The Z180 restores IEF2's saved state information when it executes a RETN (Return from Nonmaskable Interrupt) instruction.

Recommended Power Fail Routine

Z-World recommends the following routines to handle an NMI. The routines monitor the state of the /PFO line, via U18 and the data bus, to determine if the brownout condition is continuing or if the power has returned to normal levels. If you use one of these routines, you need not worry about multiple power-failure /NMIs because these routines never return from the first /NMI unless the power returns.

Program C-1. Suggested Power Fail Routine

```
main(){
    ...
}
...
char dummy[24];      // reserve dummy stack
                    // for /NMI processing
...
#define NMI_BIT 3    // routine will test data
#define NMI PIODB2  // bit 3 to determine
                    // state of /NMI line
#JUMP_VEC NMI_VEC myint
#asm
myint::
    ld    sp,dummy+24 ; force stack pointer
                    ; to top of "dummy"
                    ; array to prevent
                    ; overwriting of code
                    ; or data
;do whatever service, within allowable
;executuin time
loop:
    call hitwd      ; make sure no
                    ; watchdog reset
                    ; during brownout
    ld    bc,NMI    ; load the read-NMI
                    ; register to bc
    in   a,(c)      ; read the read-NMI
                    ; register to /PFO
    bit  NMI_BIT, a ; check /PFO status
    jr   z,loop     ; wait until brownout
                    ; condition clears
timeout:
                    ; then... a tight loop
                    ; to force a watchdog
                    ; timeout
    jp   timeout    ; which will reset the
                    ; Z180
#endasm
```

The watchdog timer should be enabled. However, if the watchdog is not enabled, you can force the processor to restart execution at 0x0000. Substitute this section for the one labeled “timeout” above.

Program C-2. Alternate Power Fail Code

```
restart:
    ld    a,0xe2    ; make sure 0x0000
                    ; points to start of
                    ; EPROM BIOS
    out0 (CBAR),a  ; set the CBAR
    jp   0000h     ; jump to logical
                    ; (physical) address
                    ; 0x0000
#endasm
```

If the DC input voltage continues to decrease, the controller powers down. The routine calls hitwd to make sure that watchdog does not timeout and thereby reset the processor. The controller can continue to run, after a fashion, at low voltage and might not be able to detect the low voltage condition, because the Z180's /NMI input needs to see a high-to-low transition edge.

A situation similar to a brownout occurs if the power supply is overloaded. For example, when an LED turns on, the raw voltage supplied to the PK2200 may dip below 7.9 V. The interrupt routine does a shutdown, which turns off the LED, clearing the problem. However, if the cause of the overload persists, the system oscillates, alternately experiencing an overload and then resetting. To correct this situation, use a power supply which can provide the needed current and voltage.

A few milliseconds of computing time remain when the regulated +5 V supply falls below ≈ 4.75 V, even if power cuts off abruptly. The amount of time depends on the size of the capacitors in the power supply. The standard wall power supply provides about 10 ms. If you remove the power cable abruptly from the PK2200 side, only the capacitors on the board are available, reducing computing time to a few hundred microseconds. These times can vary considerably depending on system's configuration and loads on the 5 V or 9 V supplies.

The interval between the power failure detection and entry to the power-failure interrupt routine is approximately 100 μ s or less if Dynamic C NMI communication is not in use.

Blank



APPENDIX D: INTERRUPT VECTORS AND I/O ADDRESSES

Appendix D provides a suggested interrupt vector map and information on EEPROM address, processor I/O addresses, and peripheral addresses.

Most of the following interrupt vectors can be altered under program control. The addresses are given in hex, relative to the start of the interrupt vector page, as determined by the contents of the I-register. These are the default interrupt vectors set by the boot code in the Dynamic C EPROM.

Interrupt Vectors

To “vector” an interrupt to a user function in Dynamic C, a directive such as the following is used:

```
#INT_VEC 0x10 myfunction
```

The above example causes the interrupt at offset 10H (serial port 1 of the Z180) to invoke the function `myfunction()`. The function must be declared with the `interrupt` keyword:

```
interrupt myfunction() {
    ...
}
```

Table D-1. Z180 Internal Device Interrupt Vectors

Address	Name	Description
0x00	INT1_VEC	Expansion bus attention /INT1 vector
0x02	INT2_VEC	/INT2 vector
0x04	PRT0_VEC	PRT timer channel 0
0x06	PRT1_VEC	PRT timer channel 1
0x08	DMA0_VEC	DMA channel 0
0x0A	DMA1_VEC	DMA channel 1
0x0C	CSIO_VEC	Clocked Serial I/O
0x0E	SER0_VEC	Asynchronous Serial Port Channel 0
0x10	SER1_VEC	Asynchronous Serial Port Channel 1

Digital input 11 connects to /INT0 and digital input 12 connects to /INT2, allowing external events to generate interrupts.

Jump Vectors

These special interrupts occur in a different manner: instead of loading the address of the interrupt routine from the interrupt vector, these interrupts cause a jump directly to the address of the vector, which contains a jump instruction to the interrupt routine. For example,

0x66 non-maskable power-failure interrupt

Because nonmaskable interrupts can be used for Dynamic C communication, your interrupt vector for power failure is normally stored just in front of the Dynamic C program. You can store a vector there by using the following command:

```
#JUMP_VEC NMI_VEC name
```

The Dynamic C communication routines relay to this vector when a power failure causes the NMI rather than a serial interrupt. Table D-2 lists interrupt priorities from the highest to lowest priority.

Table D-2. Interrupt Priorities

Interrupt Priorities	
(Highest Priority)	Trap (Illegal Instruction)
	NMI (Nonmaskable Interrupt)
	INT 0 (Maskable Interrupt, Level 0, 3 modes, PIO interrupts)
	INT 1 (Maskable Interrupt, Level 1, PLCBus attention line interrupt)
	INT 2 (Maskable Interrupt, Level 2)
	PRT Timer Channel 0
	PRT Timer Channel 1
	DMA Channel 0
	DMA Channel 1
	Clocked Serial I/O
	Serial Port 0
(Lowest Priority)	Serial Port 1

EEPROM Addresses

These EEPROM constants apply to the standard PK2200.

Table D-3. Z180 I/O Device Register Addresses

Address	Description
0x000	Startup Mode. If 1, enter program mode. If 8, execute loaded program at startup.
0x001	Baud rate in units of 1200 baud.
0x100	Unit "serial number." BCD time and date with the following format: second, minutes, hours, day, month, year.
0x108	Microprocessor clock speed in units of 1200 Hz (16-bits). For 9.216 MHz clock speed, this value is 7680. For 18.432 MHz, this value is 15,360.
0x16C	Long coefficient relating speed of microprocessor clock relative to speed of real-time clock. Nominal value is 107,374,182 which is 1/40 of a second microprocessor clock time on the scale where 2^{32} is 1 second. This value requires 4 bytes of EEPROM, stored least byte first.

Processor Register Addresses

The Z180's I/O-device registers occupy the first 40_H addresses.

Table D-4. Z180 Internal I/O Device Registers

Address	Name	Description
0x00	CNTLA0	Serial Channel 0, Control Register A
0x01	CNTLA1	Serial Channel 1, Control Register A
0x02	CNTLB0	Serial Channel 0, Control Register B
0x03	CNTLB1	Serial Channel 1, Control Register B
0x04	STAT0	Status Register, Serial Channel 0
0x05	STAT1	Status Register, Serial Channel 1
0x06	TDR0	Transmit Data Register, Serial Channel 0
0x07	TDR1	Transmit Data Register, Serial Channel 1
0x08	RDR0	Receive Data Register, Serial Channel 0
0x09	RDR1	Receive Data Register, Serial Channel 1
0x0A	CNTR	Clocked Serial Control Register
0x0B	TRDR	Clocked Serial Data Register
0x0C	TMDR0L	Timer Data Register, Channel 0, low
0x0D	TMDR0H	Timer Data Register, Channel 0, high
0x0E	RLDR0L	Timer Reload Register, Channel 0, low
0x0F	RLDR0H	Timer Reload Register, Channel 0, high
0x10	TCR	Timer Control Register
0x11–13	—	<i>Reserved</i>
0x14	TMDR1L	Timer Data Register, Channel 1, low
0x15	TMDR1H	Timer Data Register, Channel 1, high
0x16	RLDR1L	Timer Reload Register, Channel 1, low
0x17	RLDR1H	Timer Reload Register, Channel 1, high
0x18	FRC	Free-Running Counter
0x19–1E	—	<i>Reserved</i>
0x1F	CCR	CPU control register for the 18 MHz chip. Write 0x80 to get 18.432 MHz. Write 0 to get 9.216 MHz.
0x20	SAR0L	DMA Source Address, Channel 0, low

continued...

Table D-4. Z180 Internal I/O Device Registers (concluded)

Address	Name	Description
0x21	SAR0H	DMA Source Address, Channel 0, high
0x22	SAR0B	DMA Source Address, Channel 0, extra bits
0x23	DAR0L	DMA Destination Address, Channel 0, low
0x24	DAR0H	DMA Destination Address, Channel 0, most
0x25	DAR0B	Destination Address, Channel 0, extra bits
0x26	BCR0L	DMA Byte Count Register, Channel 0, low
0x27	BCR0H	DMA Byte Count Register, Channel 0, high
0x28	MAR1L	DMA Memory Address Register, Channel 1, low
0x29	MAR1H	DMA Memory Address Register, Channel 1, high
0x2A	MAR1B	DMA Memory Address Register, Channel 1, extra bits
0x2B	IAR1L	DMA I/O Address Register, Channel 1, low
0x2C	IAR1H	DMA I/O Address Register, Channel 1, high
0x2D	—	<i>Reserved</i>
0x2E	BCR1L	DMA Byte Count Register, Channel 1, low
0x2F	BCR1H	DMA Byte Count Register, Channel 1, high
0x30	DSTAT	DMA Status Register
0x31	DMODE	DMA Mode Register
0x32	DCNTL	DMA/WAIT Control Register
0x33	IL	Interrupt Vector Low Register
0x34	ITC	Interrupt/Trap Control Register
0x35	—	<i>Reserved</i>
0x36	RCR	Refresh Control Register
0x37	—	<i>Reserved</i>
0x38	CBR	MMU Common Base Register
0x39	BBR	MMU Bank Base Register
0x3A	CBAR	MMU Common/Bank Area Register
0x3B–3D	—	<i>Reserved</i>
0x3E	OMCR	Operation Mode Control Register
0x3F	ICR	I/O Control Register

PK2200 Peripheral Addresses

The following addresses control the I/O devices that are external to the Z180 processor.

Table D-5. PK2200 External I/O Device Registers

Address	Bit(s)	Symbol	Function
0x40	7	WDOG	Watchdog is “hit” (when JP3:1-2) by setting bit 7 of this address.
0x60	7	LED	Turns on LED by setting bit 7 of this address. Turn off by clearing bit 7.
0x80	7	SCL	EEPROM clock bit. Set the clock high by setting bit 7 of this address, and low by clearing bit 7.
0xA0	7	SDA_W	EEPROM serial data, write. Send data in bit 7.
0xC0	0–7	BUSRD0	First read, PLC expansion bus
0xC2	0–7	BUSRD1	Second read, PLC expansion bus
0xC4	0–7	BUSSPARE	Spare read, PLC expansion bus
0xC6	—	BUSRESET	Read this address to reset all devices on expansion bus
0xC8	0–7	BUSADR0	PLC expansion bus, first address byte
0xCA	0–7	BUSADR1	PLC expansion bus, second address byte
0xCC	0–7	BUSADR2	PLC expansion bus, third address byte
0xCE	0–7	BUSWR	Expansion bus write to port
0xE0	0–7	LCDRD LCDWR	LCD read/write register, control
0xE1	0–7	LCDRD+1 LCDWR+1	LCD read/write register, data

continued...

Table D-5. PK2200 External I/O Device Registers (continued)

Address	Bit(s)	Symbol	Function
0x100	0-3	RTALE	Real-time clock, address register
0x120	0-3	RTRW	Real-time clock, read/write data register
0x140	7	BUZZER	Self-resonating buzzer. Set bit 7 to turn on. Clear bit 7 to turn off.
0x160	7	ENB485	Set bit 7 to enable RS-485 channel. Clear bit 7 to disable.
0x180	0-7	DIGBANK1	Digital Input, Bank 1. Bit 0 corresponds to input 1; bit 7 corresponds to input 8.
0x181	0-7	DIGBANK2	Digital Input, Bank 2. Bit 0 corresponds to input 9; bit 7 corresponds to input 16.
0x1A1	4-7	KROW1L	Keypad drive row 1, rightmost 4 keys. Bit 4 is rightmost key. Bit 5 is key next to that, etc. Row 1 is the bottom-most row.
0x1A2	4-7	KROW2L	Keypad drive row 2, rightmost 4 keys. Bit 4 is rightmost key. Bit 5 is key next to that, etc.
0x1A4	4-7	KROW3L	If there were support for a 4x6 keypad, this would be drive row 3. As of now, it reads jumper JP4.
0x1A8	4-7	KROW4L	As of now, this address is <i>reserved</i> .
0x1AF	4-7	KROWAL	Keypad, <i>all</i> rows, rightmost 4 keys. Bit 4 is rightmost key. Bit 5 is key next to that, etc. Row 1 is the bottom-most row.
0x1B0	6-7	SDA_R NMI	Bit 7 represents the EEPROM SDA line. Bit 6 presents the power-failure (NMI) state.

continued...

Table D-5. PK2200 External I/O Device Registers (continued)

Address	Bit(s)	Symbol	Function
0x1B1	4–7	KROW1H	Keypad drive row 1, leftmost 2 keys. Bit 5 is leftmost key. Bit 4 is key next to that. Bit 7 represents EEPROM SDA line. Bit 6 presents power-failure (NMI) state. Row 1 is bottom-most row.
0x1B 2	4–7	KROW2H	Keypad drive row 2, leftmost 2 keys. Bit 5 is leftmost key. Bit 4 is next. Bit 7 represents EEPROM SDA line. Bit 6 presents power-failure (NMI) state.
0x1B4	4–7	KROW3H	If there were support for a 4×6 keypad, this would be drive row 3. As of now, bits 4 and 5 are <i>reserved</i> . Bit 7 is EEPROM SDA line. Bit 6 presents power-failure (NMI) state.
0x1B8	4–7	KROW4H	If there were support for a 4×6 keypad, this would be drive row 4. As of now, bits 4 and 5 are <i>reserved</i> . Bit 7 represents EEPROM SDA line. Bit 6 is power-failure (NMI) state.
0x1BF	4–7	KROWAH	Keypad, <i>all</i> rows, leftmost 2 keys. Bit 5 is the leftmost key. Bit 4 is the key next to that. Bit 7 represents the EEPROM SDA line. Bit 6 presents the power-failure (NMI) state. Row 1 is the bottom-most row.
0x1C0	5	DRV1	Digital output 1. Writing 0x20 turns on output. Writing 0 turns off output.
0x1C1	5	DRV2	Digital output 2. Writing 0x20 turns on output. Writing 0 turns off output.
0x1C2	5	DRV3	Digital output 3. Writing 0x20 turns on output. Writing 0 turns off output.

continued..

continued . . .

Table D-5. PK2200 External I/O Device Registers (concluded)

Address	Bit(s)	Symbol	Function
0x1C3	5	DRV4	Digital output 4. Writing 0x20 turns on output. Writing 0 turns off output.
0x1C4	5	DRV5	Digital output 5. Writing 0x20 turns on output. Writing 0 turns off output.
0x1C5	5	DRV6	Digital output 6. Writing 0x20 turns on output. Writing 0 turns off output.
0x1C6	5	DRV7	Digital output 7. Writing 0x20 turns on output. Writing 0 turns off output.
0x1C7	5	DRV8	Digital output 8. Writing 0x20 turns on output. Writing 0 turns off output.
0x1E0	6	DRV9	Digital output 9. Writing 0x40 turns on Outputs. Writing 0 turns off Outputs.
0x1E1	6	DRV10	Digital Outputs 10. Writing 0x40 turns on output. Writing 0 turns off output.
0x1E2	6	DRV11	Digital output 11. Writing 0x40 turns on output. Writing 0 turns off output.
0x1E3	6	DRV12	Digital output 12. Writing 0x40 turns on output. Writing 0 turns off output.
0x1E4	6	DRV13	Digital output 13. Writing 0x40 turns on output. Writing 0 turns off output.
0x1E5	6	DRV14	Digital output 14. Writing 0x40 turns on output. Writing 0 turns off output.



*APPENDIX E: **PLCBus***

Appendix E provides the pin assignments for the PLCBus, describes the registers, and lists the software drivers.

PLCBus Overview

The PLCBus is a general-purpose expansion bus for Z-World controllers. The PLCBus is available on the BL1200, BL1600, BL1700, PK2100, PK220, and PK2600 controllers. The BL1000, BL1100, BL1300, BL1400, and BL1500 controllers support the XP8300, XP8400, XP8600, and XP8900 expansion boards using the controller’s parallel input/output port. The BL1400 and BL1500 also support the XP8200 and XP8500 expansion boards. The ZB4100’s PLCBus supports most expansion boards, except for the XP8700 and the XP8800. The SE1100 adds relay expansion capability to all controllers through their digital outputs.

Table E-1 lists Z-World’s expansion devices that are supported on the PLCBus.

Table E-1. Z-World PLCBus Expansion Devices

Device	Description
EXP-A/D12	Eight channels of 12-bit A/D converters
SE1100	Four SPDT relays for use with all Z-World controllers
XP8100 Series	32 digital inputs/outputs
XP8200	“Universal Input/Output Board” —16 universal inputs, 6 high-current digital outputs
XP8300	Two high-power SPDT and four high-power SPST relays
XP8400	Eight low-power SPST DIP relays
XP8500	11 channels of 12-bit A/D converters
XP8600	Two channels of 12-bit D/A converters
XP8700	One full-duplex asynchronous RS-232 port
XP8800	One-axis stepper motor control
XP8900	Eight channels of 12-bit D/A converters

Multiple expansion boards may be linked together and connected to a Z-World controller to form an extended system.

Figure E-1 shows the pin layout for the PLCBus connector.

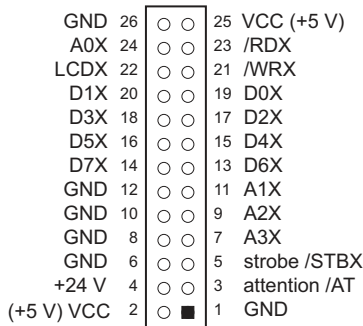

Figure E-1. PLCBus Pin Diagram

Two independent buses, the LCD bus and the PLCBus, exist on the single connector.

The LCD bus consists of the following lines.

- LCDX—positive-going strobe.
- /RDX—negative-going strobe for read.
- /WRX—negative-going strobe for write.
- A0X—address line for LCD register selection.
- D0X-D7X—bidirectional data lines (shared with expansion bus).

The LCD bus is used to connect Z-World's OP6000 series interfaces or to drive certain small liquid crystal displays directly. Figure E-2 illustrates the connection of an OP6000 interface to a controller PLCBus.

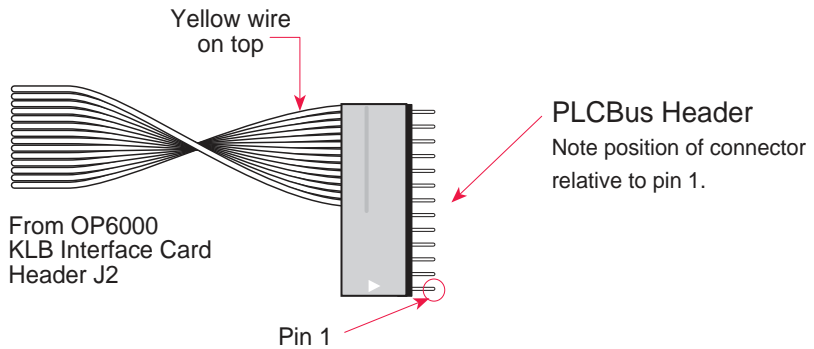

Figure E-2. OP6000 Connection to PLCBus Port

The PLCBus consists of the following lines.

- /STBX—negative-going strobe.
- A1X-A3X—three control lines for selecting bus operation.
- D0X-D3X—four bidirectional data lines used for 4-bit operations.
- D4X-D7X—four additional data lines for 8-bit operations.
- /AT—attention line (open drain) that may be pulled low by any device, causing an interrupt.

The PLCBus may be used as a 4-bit bus (D0X-D3X) or as an 8-bit bus (D0X-D7X). Whether it is used as a 4-bit bus or an 8-bit bus depends on the encoding of the address placed on the bus. Some PLCBus expansion cards require 4-bit addressing and others (such as the XP8700) require 8-bit addressing. These devices may be mixed on a single bus.

There are eight registers corresponding to the modes determined by bus lines A1X, A2X, and A3X. The registers are listed in Table E-2.

Table E-2. PLCBus Registers

Register	Address	A3	A2	A1	Meaning
BUSRD0	C0	0	0	0	Read data, one way
BUSRD1	C2	0	0	1	Read data, another way
BUSRD2	C4	0	1	0	Spare, or read data
BUSRESET	C6	0	1	1	Read this register to reset the PLCBus
BUSADR0	C8	1	0	0	First address nibble or byte
BUSADR1	CA	1	0	1	Second address nibble or byte
BUSADR2	CC	1	1	0	Third address nibble or byte
BUSWR	CE	1	1	1	Write data

Writing or reading one of these registers takes care of all the bus details. Functions are available in Z-World’s software libraries to read from or write to expansion bus devices.

To communicate with a device on the expansion bus, first select a register associated with the device. Then read or write from/to the register. The register is selected by placing its address on the bus. Each device recognizes its own address and latches itself internally.

A typical device has three internal latches corresponding to the three address bytes. The first is latched when a matching BUSADR0 is detected. The second is latched when the first is latched and a matching BUSADR1 is detected. The third is latched if the first two are latched and a matching BUSADR2 is detected. If 4-bit addressing is used, then there are three 4-bit address nibbles, giving 12-bit addresses. In addition, a special register address is reserved for address expansion. This address, if ever used, would provide an additional four bits of addressing when using the 4-bit convention.

If eight data lines are used, then the addressing possibilities of the bus become much greater—more than 256 million addresses according to the conventions established for the bus.

Place an address on the bus by writing (bytes) to BUSADR0, BUSADR1 and BUSADR2 in succession. Since 4-bit and 8-bit addressing modes must coexist, the lower four bits of the first address byte (written to BUSADR0) identify addressing categories, and distinguish 4-bit and 8-bit modes from each other.

There are 16 address categories, as listed in Table E-3. An “x” indicates that the address bit may be a “1” or a “0.”

Table E-3. First-Level PLCBus Address Coding

First Byte	Mode	Addresses	Full Address Encoding
– – – – 0 0 0 0	4 bits × 3	256	0000 xxxx xxxx
– – – – 0 0 0 1		256	0001 xxxx xxxx
– – – – 0 0 1 0		256	0010 xxxx xxxx
– – – – 0 0 1 1		256	0011 xxxx xxxx
– – – x 0 1 0 0	5 bits × 3	2,048	x0100 xxxxxx xxxxxx
– – – x 0 1 0 1		2,048	x0101 xxxxxx xxxxxx
– – – x 0 1 1 0		2,048	x0110 xxxxxx xxxxxx
– – – x 0 1 1 1		2,048	x0111 xxxxxx xxxxxx
– – x x 1 0 0 0	6 bits × 3	16,384	xx1000 xxxxxx xxxxxx
– – x x 1 0 0 1		16,384	xx1001 xxxxxx xxxxxx
– – x x 1 0 1 0	6 bits × 1	4	xx1010
– – – – 1 0 1 1	4 bits × 1	1	1011 (expansion register)
x x x x 1 1 0 0	8 bits × 2	4,096	xxxx1100 xxxxxxxx
x x x x 1 1 0 1	8 bits × 3	1M	xxxx1101 xxxxxxxx xxxxxxxx
x x x x 1 1 1 0	8 bits × 1	16	xxxx1110
x x x x 1 1 1 1	8 bits × 1	16	xxxx1111

This scheme uses less than the full addressing space. The mode notation indicates how many bus address cycles must take place and how many bits are placed on the bus during each cycle. For example, the 5 × 3 mode means three bus cycles with five address bits each time to yield 15-bit addresses, not 24-bit addresses, since the bus uses only the lower five bits of the three address bytes.

Z-World provides software drivers that access the PLCBus. To allow access to bus devices in a multiprocessing environment, the expansion register and the address registers are shadowed with memory locations known as *shadow registers*. The 4-byte shadow registers, which are saved at predefined memory addresses, are as follows.

	SHBUS0	SHBUS0+1	SHBUS1 SHBUS0+2	SHBUS1+1 SHBUS0+3
Bus expansion		BUSADR0	BUSADR1	BUSADR2

Before the new addresses or expansion register values are output to the bus, their values are stored in the shadow registers. All interrupts that use the bus save the four shadow registers on the stack. Then, when exiting the interrupt routine, they restore the shadow registers and output the three address registers and the expansion registers to the bus. This allows an interrupt routine to access the bus without disturbing the activity of a background routine that also accesses the bus.

To work reliably, bus devices must be designed according to the following rules.

1. The device must not rely on critical timing such as a minimum delay between two successive register accesses.
2. The device must be capable of being selected and deselected without adversely affecting the internal operation of the controller.

Allocation of Devices on the Bus

4-Bit Devices

Table E-4 provides the address allocations for the registers of 4-bit devices.

Table E-4. Allocation of Registers

A1	A2	A3	Meaning
000j	000j	xxxj	digital output registers, 64 registers $64 \times 8 = 512$ 1-bit registers
000j	001j	xxxj	analog output modules, 64 registers
000j	01xj	xxxj	digital input registers, 128 registers $128 \times 4 = 512$ input bits
000j	10xj	xxxj	analog input modules, 128 registers
000j	11xj	xxxj	128 spare registers (customer)
001j	xxxj	xxxj	512 spare registers (Z-World)

j controlled by board jumper
x controlled by PAL

Digital output devices, such as relay drivers, should be addressed with three 4-bit addresses followed by a 4-bit data write to the control register. The control registers are configured as follows

bit 3	bit 2	bit 1	bit 0
A2	A1	A0	D

The three address lines determine which output bit is to be written. The output is set as either 1 or 0, according to D. If the device exists on the bus, reading the register drives bit 0 low. Otherwise bit 0 is a 1.

For digital input, each register (BUSRD0) returns four bits. The read register, BUSRD1, drives bit 0 low if the device exists on the bus.

8-Bit Devices

Z-World’s XP8700 and XP8800 expansion boards use 8-bit addressing. Refer to the *XP8700 and XP8800* manual.

Expansion Bus Software

The expansion bus provides a convenient way to interface Z-World’s controllers with expansion boards or other specially designed boards. The expansion bus may be accessed by using input functions. Follow the suggested protocol. The software drivers are easier to use, but are less efficient in some cases. Table E-5 lists the libraries.

Table E-5. Dynamic C PLCBus Libraries

Library Needed	Controller
DRIVERS.LIB	All controllers
EZIOTGPL.LIB	BL1000
EZIOLGPL.LIB	BL1100
EZIOMGPL.LIB	BL1400, BL1500
EZIOPLC.LIB	BL1200, BL1600, PK2100, PK2200, ZB4100
EZIOPLC2.LIB	BL1700, PK2600
PBUS_TG.LIB	BL1000
PBUS_LG.LIB	BL1100, BL1300
PLC_EXP.LIB	BL1200, BL1600, PK2100, PK2200

There are 4-bit and 8-bit drivers. The 4-bit drivers employ the following calls.

- **void eioResetPlcBus ()**

Resets all expansion boards on the PLCBus. When using this call, make sure there is sufficient delay between this call and the first access to an expansion board.

LIBRARY: **EZIOPLC.LIB, EZIOPLC2.LIB, EZIOMGPL.LIB.**

- **void eioPlcAdr12(unsigned addr)**

Specifies the address to be written to the PLCBus using cycles BUSADR0, BUSADR1, and BUSADR2.

PARAMETER: **addr** is broken into three nibbles, and one nibble is written in each BUSADR_x cycle.

LIBRARY: **EZIOPLC.LIB, EZIOPLC2.LIB, EZIOMGPL.LIB.**

- **void set16adr(int adr)**

Sets the current address for the PLCBus. All read and write operations access this address until a new address is set.

PARAMETER: **adr** is a 16-bit physical address. The high-order nibble contains the value for the expansion register, and the remaining three 4-bit nibbles form a 12-bit address (the first and last nibbles must be swapped).

LIBRARY: **DRIVERS.LIB.**

- **void set12adr(int adr)**

Sets the current address for the PLCBus. All read and write operations access this address until a new address is set.

PARAMETER: **adr** is a 12-bit physical address (three 4-bit nibbles) with the first and third nibbles swapped.

LIBRARY: **DRIVERS.LIB.**

- **void eioPlcAdr4(unsigned addr)**

Specifies the address to be written to the PLCBus using only cycle BUSADR2.

PARAMETER: **addr** is the nibble corresponding to BUSADR2.

LIBRARY: **EZIOPLC.LIB, EZIOPLC2.LIB, EZIOMGPL.LIB.**

- **void set4adr(int adr)**

Sets the current address for the PLCBus. All read and write operations access this address until a new address is set.

A 12-bit address may be passed to this function, but only the last four bits will be set. Call this function only if the first eight bits of the address are the same as the address in the previous call to **set12adr**.

PARAMETER: **adr** contains the last four bits (bits 8–11) of the physical address.

LIBRARY: **DRIVERS.LIB**.

- **char _eioReadD0()**

Reads the data on the PLCBus in the BUSADR0 cycle.

RETURN VALUE: the byte read on the PLCBus in the BUSADR0 cycle.

LIBRARY: **EZIOPLC.LIB, EZIOPLC2.LIB, EZIOMGPL.LIB**.

- **char _eioReadD1()**

Reads the data on the PLCBus in the BUSADR1 cycle.

RETURN VALUE: the byte read on the PLCBus in the BUSADR1 cycle.

LIBRARY: **EZIOPLC.LIB, EZIOPLC2.LIB, EZIOMGPL.LIB**.

- **char _eioReadD2()**

Reads the data on the PLCBus in the BUSADR2 cycle.

RETURN VALUE: the byte read on the PLCBus in the BUSADR2 cycle.

LIBRARY: **EZIOPLC.LIB, EZIOPLC2.LIB, EZIOMGPL.LIB**.

- **char read12data(int adr)**

Sets the current PLCBus address using the 12-bit **adr**, then reads four bits of data from the PLCBus with BUSADR0 cycle.

RETURN VALUE: PLCBus data in the lower four bits; the upper bits are undefined.

LIBRARY: **DRIVERS.LIB**.

- **char read4data(int adr)**

Sets the last four bits of the current PLCBus address using `adr` bits 8–11, then reads four bits of data from the bus with `BUSADR0` cycle.

PARAMETER: `adr` bits 8–11 specifies the address to read.

RETURN VALUE: PLCBus data in the lower four bits; the upper bits are undefined.

LIBRARY: `DRIVERS.LIB`.

- **void _eioWriteWR(char ch)**

Writes information to the PLCBus during the `BUSWR` cycle.

PARAMETER: `ch` is the character to be written to the PLCBus.

LIBRARY: `EZIOPLC.LIB`, `EZIOPLC2.LIB`, `EZIOGPL.LIB`.

- **void write12data(int adr, char dat)**

Sets the current PLCBus address, then writes four bits of data to the PLCBus.

PARAMETER: `adr` is the 12-bit address to which the PLCBus is set.

`dat` (bits 0–3) specifies the data to write to the PLCBus.

LIBRARY: `DRIVERS.LIB`.

- **void write4data(int address, char data)**

Sets the last four bits of the current PLCBus address, then writes four bits of data to the PLCBus.

PARAMETER: `adr` contains the last four bits of the physical address (bits 8–11).

`dat` (bits 0–3) specifies the data to write to the PLCBus.

LIBRARY: `DRIVERS.LIB`.

The 8-bit drivers employ the following calls.

- **void set24adr(long address)**

Sets a 24-bit address (three 8-bit nibbles) on the PLCBus. All read and write operations will access this address until a new address is set.

PARAMETER: `address` is a 24-bit physical address (for 8-bit bus) with the first and third bytes swapped (low byte most significant).

LIBRARY: `DRIVERS.LIB`.

- **void set8adr(long address)**

Sets the current address on the PLCBus. All read and write operations will access this address until a new address is set.

PARAMETER: **address** contains the last eight bits of the physical address in bits 16–23. A 24-bit address may be passed to this function, but only the last eight bits will be set. Call this function only if the first 16 bits of the address are the same as the address in the previous call to **set24adr**.

LIBRARY: **DRIVERS.LIB**.

- **int read24data0(long address)**

Sets the current PLCBus address using the 24-bit address, then reads eight bits of data from the PLCBus with a BUSRD0 cycle.

RETURN VALUE: PLCBus data in lower eight bits (upper bits 0).

LIBRARY: **DRIVERS.LIB**.

- **int read8data0(long address)**

Sets the last eight bits of the current PLCBus address using address bits 16–23, then reads eight bits of data from the PLCBus with a BUSRD0 cycle.

PARAMETER: **address** bits 16–23 are read.

RETURN VALUE: PLCBus data in lower eight bits (upper bits 0).

LIBRARY: **DRIVERS.LIB**.

- **void write24data(long address, char data)**

Sets the current PLCBus address using the 24-bit address, then writes eight bits of data to the PLCBus.

PARAMETERS: **address** is 24-bit address to write to.

data is data to write to the PLCBus.

LIBRARY: **DRIVERS.LIB**.

- **void write8data(long address, char data)**

Sets the last eight bits of the current PLCBus address using address bits 16–23, then writes eight bits of data to the PLCBus.

PARAMETERS: **address** bits 16–23 are the address of the PLCBus to write.

data is data to write to the PLCBus.

LIBRARY: **DRIVERS.LIB**.

Blank



*APPENDIX F: **BACKUP BATTERY***

Battery Life and Storage Conditions

The ten-year estimated life of a battery on the PK2200 is based on typical use. Most systems are operated on a continuous basis with the battery only powering the SRAM and real time clock during power outages and/or routine maintenance. A ten-year life expectancy is an estimate that reflects the shelf-life of a lithium battery with occasional usage rather than the ability of the battery to power the circuitry full time.

The battery on the PK2200 has a 165 mA·h capacity. Older versions of the PK2200 have a Toshiba clock that consumes 8 μ A in idle mode. Newer boards have an Epson clock that consumes 3 μ A in idle mode. In standby mode, SRAM consumes from a low of 1 μ A (32K SRAM) to a high of 8 μ A (512K SRAM). If a system were unpowered 100 percent of the time, the battery life with a Toshiba clock will be approximately 18,300 hours (2.1 years), and with an Epson clock will be approximately 41,250 hours (4.7 years). All life-expectancy ranges are based on normal operating temperatures of 25°C.

Backup time longevity is affected by many factors, including the amount of time the controller is not powered, and the SRAM size. To help achieve a full ten years of backup, a larger capacity cell can replace the BR2325. Alkaline batteries (mounted external to the board, like in many PCs) can easily and cheaply give over ten years of backup.

The controller should be stored at room temperature in the factory packaging until field installation. Take care that the controller is not exposed to extreme temperature, humidity, and/or contaminants such as dust and chemicals.

To ensure maximum battery shelf life, follow proper storage procedures. Replacement batteries should be kept sealed in the factory packaging at room temperature until installation. Protection against environmental extremes will help maximize battery life.

Replacing Soldered Lithium Battery

Use the following steps to replace the battery.

1. Locate the three pins on the bottom side of the printed circuit board that secure the battery to the board.
2. Carefully de-solder the pins and remove the battery. Use a solder sucker to clean up the holes.
3. Install the new battery and solder it to the board. Use only a Panasonic BR2325-1GM or equivalent.

Battery Cautions

- **Caution (English)**

There is a danger of explosion if battery is incorrectly replaced. Replace only with the same or equivalent type recommended by the manufacturer. Dispose of used batteries according to the manufacturer's instructions.

- **Warnung (German)**

Explosionsgefahr durch falsches Einsetzen oder Behandeln der Batterie. Nur durch gleichen Typ oder vom Hersteller empfohlenen Ersatztyp ersetzen. Entsorgung der gebrauchten Batterien gemäß den Anweisungen des Herstellers.

- **Attention (French)**

Il y a danger d'explosion si la remplacement de la batterie est incorrect. Remplacez uniquement avec une batterie du même type ou d'un type équivalent recommandé par le fabricant. Mettez au rebut les batteries usagées conformément aux instructions du fabricant.

- **Cuidado (Spanish)**

Peligro de explosión si la pila es instalada incorrectamente. Reemplace solamente con una similar o de tipo equivalente a la que el fabricante recomienda. Deshagase de las pilas usadas de acuerdo con las instrucciones del fabricante.

- **Waarschuwing (Dutch)**

Explosiegevaar indien de batterij niet goed wordt vervagen. Vervanging alleen door een zelfde of equivalent type als aanbevolen door de fabrikant. Gebruikte batterijen afvoeren als door de fabrikant wordt aangegeven.

- **Varning (Swedish)**

Explosionsfara vid felaktigt batteritype. Använd samma batterityp eller en likvärdigt typ som rekommenderas av fabrikanten. Kassera använt batteri enligt fabrikantens instruktion.

Blank

Symbols

#INT_VEC	41, 86
#JUMP_VEC	87
/AT	97
/DREQ1	26
/INT0	26
/INT2	26
/RDX	97
/STBX	97
/WRX	97
<Ctrl F9>	20
=(assignment) use	68
_DMAFLAG0	53
_DMAFLAG1	53
4-bit bus operations ...	97, 98, 100
5 × 3 addressing mode	99
5KEYCODE.C	62
5KEYDEMO.C	62
5KEYLAD.C	62
8-bit bus operations ...	97, 99, 101
9th-bit binary protocol	63

A

A0X	97
A1X, A2X, A3X	97, 98
addresses	
digital input	52
EEPROM	88
encoding	99
I/O register	89
modes	99
peripheral I/O	91
PLCBus	98, 99
ASCII characters	
and modem commands	39
asynchronous serial port	
Channel 0	86
Channel 1	86

attention line	97
attention line interrupt	87

B

background routine	100
battery	
backup	80
replacing	108
baud rate	29, 88
BBR	89
BCR0H	89
BCR0L	89
BCR1H	89
BCR1L	89
beeper	
sounding	55
bidirectional data lines	97
bitmapped graphics	47
bitmaps	47
board dimensions	73
board jumpers	34
brownout	83
buffer	
receive	38, 39
transmit	38
bus	
control registers	101
digital inputs	101
expansion	
96, 97, 98, 99, 100, 101	
4-bit drivers	102
8-bit drivers	104
addresses	100
devices	100, 101
functions 102, 103, 104, 105	
rules for devices	100
software drivers	101
LCD	97

bus (continued)
 operations
 4-bit..... 97, 98, 100
 8-bit..... 97, 101
 BUSADR0 91, 98, 99
 BUSADR1 91, 98, 99
 BUSADR2 91, 98, 99
 BUSADR3 104, 105
 BUSRD0 91, 101, 102, 103, 105
 BUSRD1 91, 101, 102
 BUSRESET 91
 BUSSPARE 91
 BUSWR 91, 102
 BUZZER 91
 byte aligned 47

C

calibration constants 88
 carriage return (CR)
 as modem command terminator .
 39
 CBAR 89
 CBR 89
 CCR 89
 CE compliance 16
 CKA0/DREQ0 26
 clock
 real time 86
 real-time 88, 91
 system 29, 88
 time/date 50
 clock frequency
 system 88
 clocked serial control register 89
 clocked serial data register 89
 clocked serial I/O 86, 87
 CN2 26
 CNTLA0 89
 CNTLA1 89
 CNTLBO 89
 CNTLB1 89
 CNTR 89
 column major 47

COMMAND mode
 modem communication 39
 common problems
 programming errors 68
 communication
 Dynamic C 87
 error 19
 initialization routines 40
 RS-232 29, 63
 RS-485 29, 63
 serial 29, 38, 63
 interrupts 38

Compile

 icon 20
 program 20
 connect PK2200 to PC 18
 connectors 42, 76
 26-pin PLCBus
 pin assignments 96
 constants
 calibration 88
 core 23
 counters 26, 36
 DMA 53
 inputs 36, 53
 CPU 23
 CSIO_VEC 86
 CSREMOTE.C 63
 CTS 38, 39, 40
 CUARTREM.C 63
 customization 15
 CZOREM.C 63

D

D0X-D7X 97
 DAR0B 89
 DAR0L 89
 DATA mode
 modem communication 39
 date and time 50, 63, 88
 DCNTL 89
 Development Kit 15
 DIGBANK1 91

DIGBANK2	91	DRIVERS.LIB	101
digital inputs	24, 26, 36, 62	dropout voltage	80
drivers	52	DRV10	91
reading	52	DRV11	91
multiple inputs	52	DRV4	91
virtual driver variables	52	DRV5	91
digital outputs	27, 37, 54, 91	DRV6	91
drivers	52	DRV7	91
virtual driver variables	54	DRV8	91
writing	54	DRV9	91
Dinit_uart	40	DSTAT	89
Dinit_z0	40	DTR	40
Dinit_z1	40	Dynamic C	
DIP relays	96	communication	87
display	31, 43	error messages	19
liquid crystal. <i>See</i> LCD		programming	34
dissipation		E	
heat	75	echo option	38, 39
DMA	89	edges	
DMA channels	26, 36, 53	counting	37
DMA Channel 0	86, 87	ee_rd	51
DMA Channel 1	86, 87	ee_wr	51
DMA counter	53	EEPROM	24, 51, 91
DMA interrupts	53	constants	86
DMA/WAIT	89	reading	51
DMA0_VEC	86	writing	51
DMA1_VEC	86	EEPROM addresses	88
DMA0Count	53	eioPlcAdr12	102
DMA1Count	53	eioReadD0	103
DMASnapShot	53	eioReadD1	103
DMODE	89	eioReadD2	103
downloading data	38, 39	eioResetPlcBus	102
downloading programs	41	eioWriteWR	104
drivers		electrical and environmental	
digital input	52	specifications	70
digital output	52	ENB485	91
expansion bus	101	environmental constraints	75
4-bit	102	EPROM	36
8-bit	104	error messages	19, 20
high voltage	27	establishing communication	19
relay	101	Exp-A/D12	96
sinking	27		
software	50		
sourcing	28		

expansion boards	
reset	102
expansion bus	86, 87, 91, 96–101
4-bit drivers	102
8-bit drivers	104
addresses	100
devices	100, 101
digital inputs	101
functions	102–105
rules for devices	100
software drivers	101
expansion register	100
EZIOLGPL.LIB	101
EZIOMGPL.LIB	101
EZIOPL2.LIB	101
EZIOPLC.LIB	101
EZIOTGPL.LIB	101
F	
F3	20
F9	20
features	12
five-key system	
sample program	62
flash EPROM	36
float	
use	68
fonts	58, 59
format	
bitmapped image	47
FRC	89
frequency	
system clock	88
function libraries	98
G	
getting started	17
glBlankScreen	57
glFontInit	58
glInit	57
glPlotCircle	60
glPlotDot	57
glPlotLine	57
glPrintf	60
glPutBitmap	57
glPutFont	59
glSetBrushType	56
glVPrintf	59
glXFontInit	59
glXPutBitmap	58
H	
halt program	20
handshaking	
RS-232	38
Hayes Smart Modem	40
headers	76
heat dissipation	75
high-current output drivers	22
high-voltage drivers	27
holdup time	81
hooking up the PK2200	19
I	
I/O addresses	89, 91
I/O control register	89
I/O devices	91
I/O map	89, 91
I/O register addresses	89
IAR1H	89
IAR1L	89
ICR	89
IL	89
illegal instruction interrupt	87
initial PK2200 setup	34
initialization routines	
communication	40
inport	52, 102, 103, 105
inputs	
counter	53
digital	24, 26, 36, 62
inserts	
keypad	44
int	
type specifier, use	68

INT1	87	K	
INT1_VEC	86	kdiELSw	60
INT2	87	kdiSetContrast	60
INT2_VEC	86	keypad	31, 34, 55, 91
interface		2 x 6	34
operator	31	4 x 3	35
interrupt handling for Z180 Port 0 ..	41	initialization	55, 61, 62
interrupt routines	83, 87	mode settings	34
interrupt vector		reading	61, 62
CSIO_VEC	86	states	61
DMA0_VEC	86	keypad inserts	44
DMA1_VEC	86	KP.LIB	55
INT1_VEC	86	kpDefGetKey	62
INT2_VEC	86	kpDefInit	62
PRT0_VEC	86	kpDefStChgFn	61
PRT1_VEC	86	kpInit	61
SER0_VEC	86	kpScanState	61
SER1_VEC	86	KROW1L	91
interrupt vector low register	89	KROW2L	91
interrupt vectors	87	KROW3L	91
default	86	KROW4L	91
interrupt/trap control register	89	KROWAL	91
interrupts	26, 36, 86, 87, 97, 100	L	
attention line	87	lc_char	55
DMA	53	lc_cmd	56
illegal instruction	87	lc_ctrl	56
nonmaskable	83, 87	lc_init	56
power-fail	80, 83, 87	lc_init_keypad	55
routines	100	lc_kxget	55
serial	41, 87	lc_kxinit	55
serial communication	38	lc_nl	56
T0 output	87	lc_pos	56
ITC	89	lc_printf	56
J		lc_setbeep	55
jumper settings	34, 77, 86	lc_wait	56
JP1 (digital outputs)	28, 77	LCD	46, 55, 91, 97
JP2 (digital inputs)	25, 77	backlighting	43
JP3 (run/program mode) .	34, 35	busy	56
JP3 (serial communication) .	30, 77	character	43
JP4 (run/program mode)	77	graphic	43
JP5 (EEPROM write-protect)	77	backlighting	60
JP6 (EPROM/flash EPROM)	77	clear display	57

LCD	
graphic (continued)	
contrast	60
drawing	56, 57, 58, 60
font initialization	58, 59
initialization	57
turning display ON/OFF	60
writing	59, 60
initialization	56
positioning text	56
writing	55, 56
commands	56
LCD bus	97
LCDRD	91
LCDWR	91
LCDX	97
leap year	50
LED	83, 91
libraries	
function	98
liquid crystal display. <i>See</i> LCD	
l iteral (C term)	
use	68
lithium battery	108
M	
MAR1B	89
MAR1H	89
MAR1L	89
master-slave communication	63
mechanical dimensions	71–74
MMU bank base register	89
MMU common base register	89
MMU common/bank area register .	
.....	89
mode	
startup	88
MODEM	38, 39
modem commands	39
termination	39
modem communication	41, 63
serial link wiring	40
modes	
addressing	99
operating	34
N	
NMI	80, 83, 87, 91
NMI_VEC	87
NO_CARRIER message	39
nonmaskable interrupt. <i>See</i> NMI	
NULL modem	40
O	
OMCR	89
operating modes	34
operation mode control register ...	89
operator interface	31
Opto22 9th-bit binary protocol	63
o utport	54, 102, 103, 105
outputs	
digital	27, 37, 54, 91
overload protection	24
P	
peripheral I/O addresses	91
pinouts	
PLCBus	96
PK2200	
connect to PC	18
establish communication	19
features	12
hook-up	19
subsystems	21
PLCBus	86, 87, 91, 96–98,
100, 101	
26-pin connector	
pin assignments	96
4-bit operations	97, 99
8-bit operations	97, 99
addresses	98, 99
memory-mapped I/O register .	98
reading data	98

PLCBus (continued)	real-time clock 24, 50, 86, 88, 91
relays	reading 50
DIP 96	writing 50
drivers 101	real-time kernel 62
writing data 98	receive buffer 38, 39
ports	receive data register 89
serial 38	refresh control register 89
power failure	regulated input voltage 80
detection 80	RELOAD_VEC 41
interrupts 80, 83, 87	remote downloading 41, 63
recommended routine 82	reset
power management 79	controller 19
power supply 18, 83	expansion boards 102
overload 83	system 80
program	RLDR0H 89
run 20	RLDR0L 89
program development 35	RLDR1H 89
programming	RLDR1L 89
remote 41	RS-232 29, 38
programming cable 18	communication 63
protected digital inputs 22	expansion card 38, 39, 40
protocol	handshaking 38
9th-bit binary 63	jumper settings 30
Opto22 63	RS-485 29
XMODEM 38, 39	channel 91
PRT timer	communication 63
Channel 0 86, 87	jumper settings 30
Channel 1 86, 87	network 42
PRT0_VEC 86	RTALE 91
PRT1_VEC 86	RTK 62
pulse measurement 37	RTRW 91
	RTS 38, 39, 40
R	RX line 40
RAM 23, 35	
RCR 89	S
RDR0 89	sample program 20, 62
RDR1 89	SAR0B 89
read12data 103	SAR0H 89
read24data 105	SAR0L 89
read4data 104	SCL 91
read8data 105	screw terminals 42, 76
reading data on the PLCBus	SDA_R 91
..... 98, 103	SDA_W 91

SE1100	96	STAT0	89
select PLCBus address	102	STAT1	89
SER0_VEC	41, 86	struct tm	50
SER1_VEC	86	supervisor	23
Serial Channel 0		system clock	88
control register B	89	frequency	29, 88
receive data register	89		
status register	89	T	
transmit data register	89	T0 output interrupt	87
Serial Channel 1		target not responding	19
control register A	89	TCR	89
control register B	89	TDR0	89
receive data register	89	TDR1	89
status register	89	templates	
transmit data register	89	keypad insert	44
serial channels		text	
configuring	30	displaying on graphic LCD	
serial communication ... 29, 38, 63		59, 60
channels	22	time and date	50, 63, 88
serial interrupts	41, 87	time/date clock	50
serial link wiring	40	timer control register	89
Serial Port 0	87	timer data register	
Serial Port 1	87	Channel 0	89
serial ports	38	Channel 1	89
set12adr	102	timer reload register	
set16adr	102	Channel 0	89
set24adr	104	Channel 1	89
set4adr	103	tm	50
set8adr	105	tm_rd	50
shadow registers	100	tm_wr	50
sinking drivers	27	TMDR0H	89
software		TMDR0L	89
drivers	50	TMDR1H	89
libraries	62, 98	TMDR1L	89
source (C term)		transmit buffer	38
use	68	transmit data register	89
sourcing drivers	28	trap	87
specifications	69	TRDR	89
electrical and environmental ..	70	troubleshooting	
stack overflow	81	baud rate	67
standby mode	80	cables	66
startup mode	88	com port	66, 67

troubleshooting (continued)	write12data	104
communication mode	write24data	105
expansion boards	write4data	104
grounds	write8data	105
memory size	writing data on the PLCBus ...	98, 104
operating mode	wtDisplaySw	60
repeated resets	X	
TX line	XMODEM	38, 39
U	XMODEM download	63
UDN2985A	XMODEM upload	63
ULN2803	XP8100	96
unregulated input voltage	XP8200	96
up_beep	XP8300	96
up_digin	XP8400	96
up_setout	XP8500	96
uploading data	XP8600	96
V	XP8700	96, 97, 101
VIOInit	XP8800	96, 101
VIODrvr	XP8900	96
W	Z	
watchdog	Z180 Port 0	38–41
WDOG	interrupt handling	41
WINTEK.LIB	Z180 Port 1	38, 86

Blank

SCHEMATICS

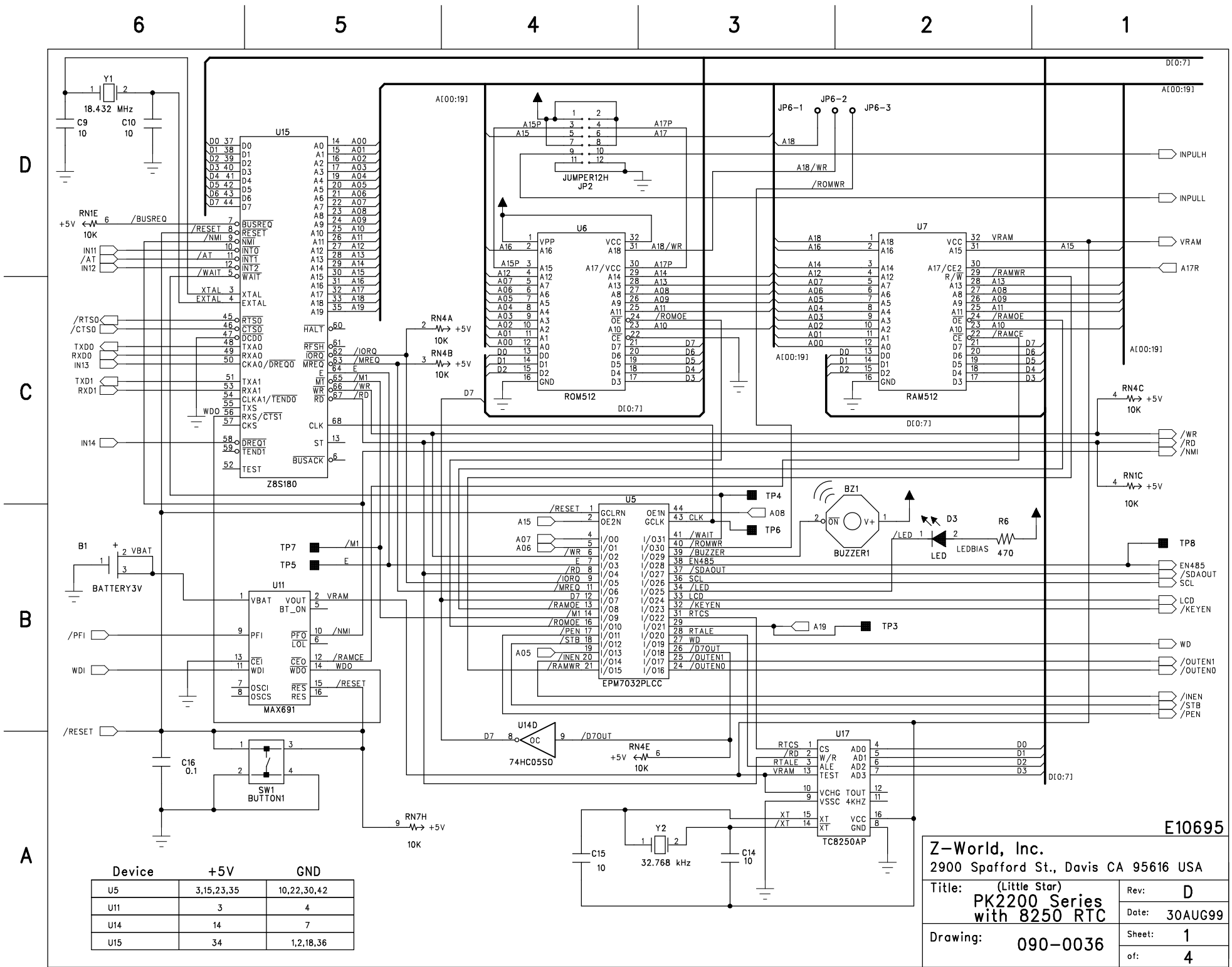

Device	+5V	GND
U5	3,15,23,35	10,22,30,42
U11	3	4
U14	14	7
U15	34	1,2,18,36

E10695

Z-World, Inc.
 2900 Spafford St., Davis CA 95616 USA

Title: (Little Star) PK2200 Series with 8250 RTC	Rev: D
Drawing: 090-0036	Date: 30AUG99
	Sheet: 1
	of: 4

6

5

4

3

2

1

D

C

B

A

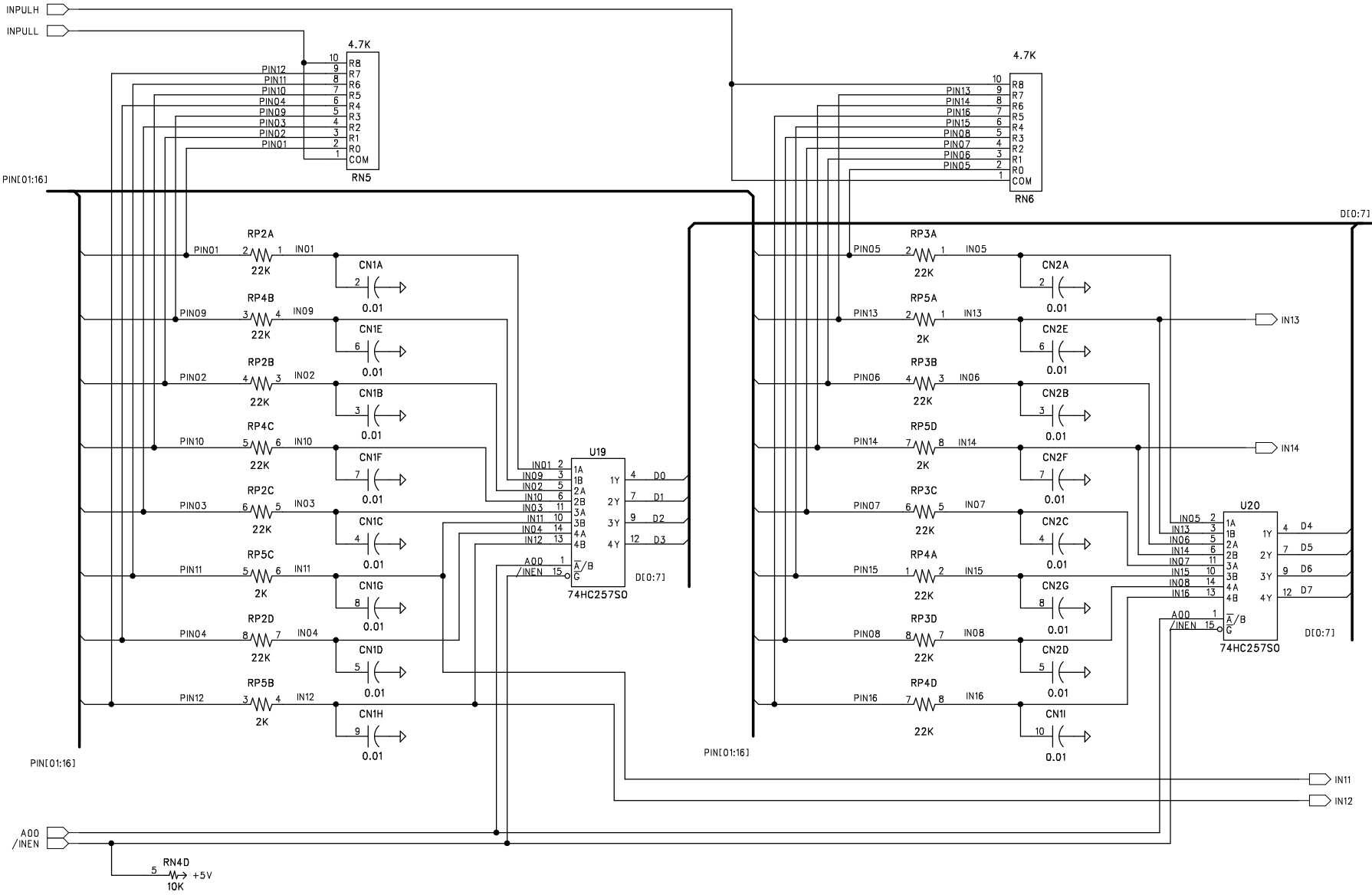

Device	+5V	GND
U19, U20	16	8

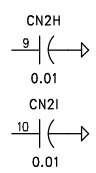

E10695

Z-World, Inc. 2900 Spafford St., Davis CA 95616 USA	
Title: (Little Star) PK2200 Series with 8250 RTC	Rev: D
Drawing: 090-0036	Date: 30AUG99
	Sheet: 2
	of: 4

6

5

4

3

2

1

D

C

B

A

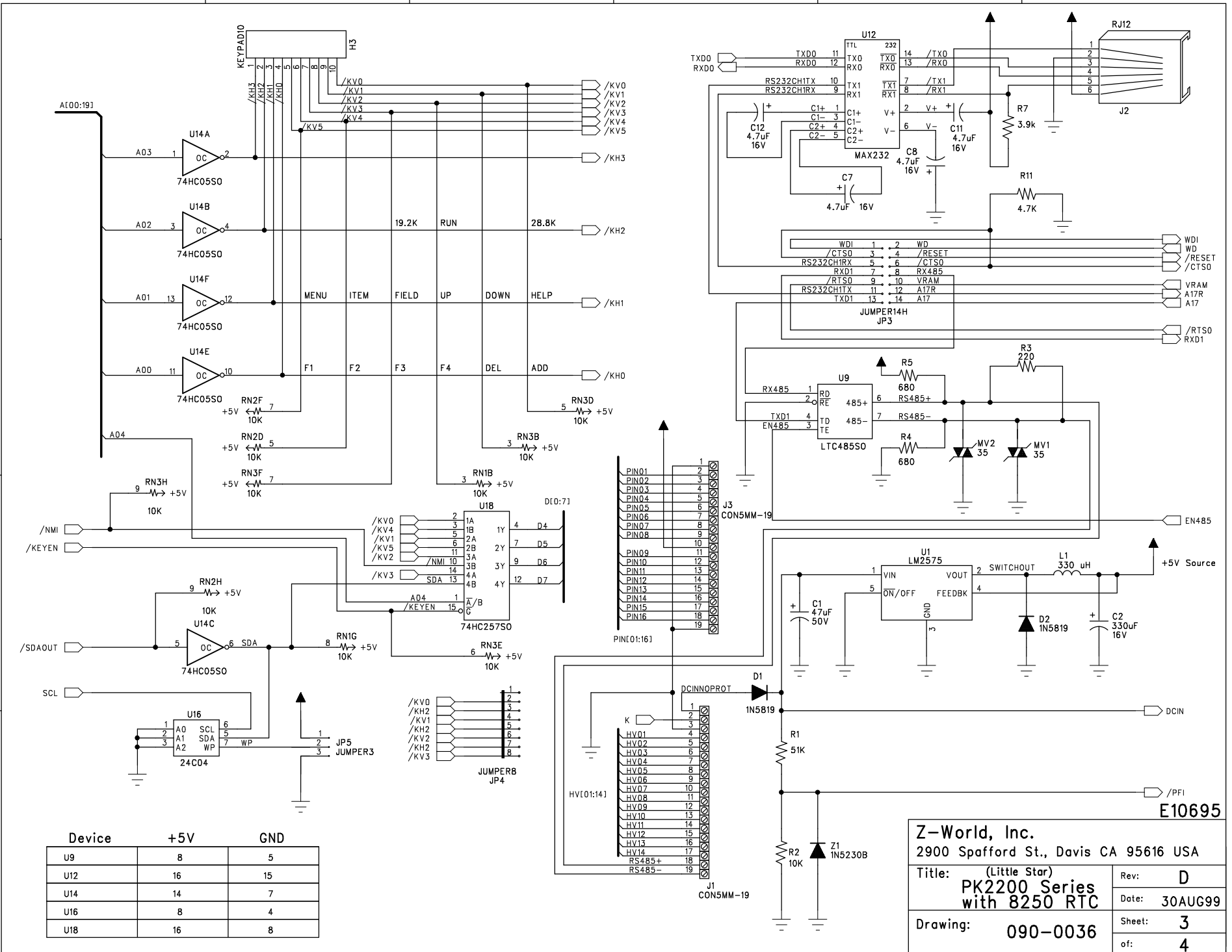

E10695

Z-World, Inc.
2900 Spafford St., Davis CA 95616 USA

Title: (Little Star)
PK2200 Series
with 8250 RTC

Rev: D

Date: 30AUG99

Drawing: 090-0036

Sheet: 3

of: 4

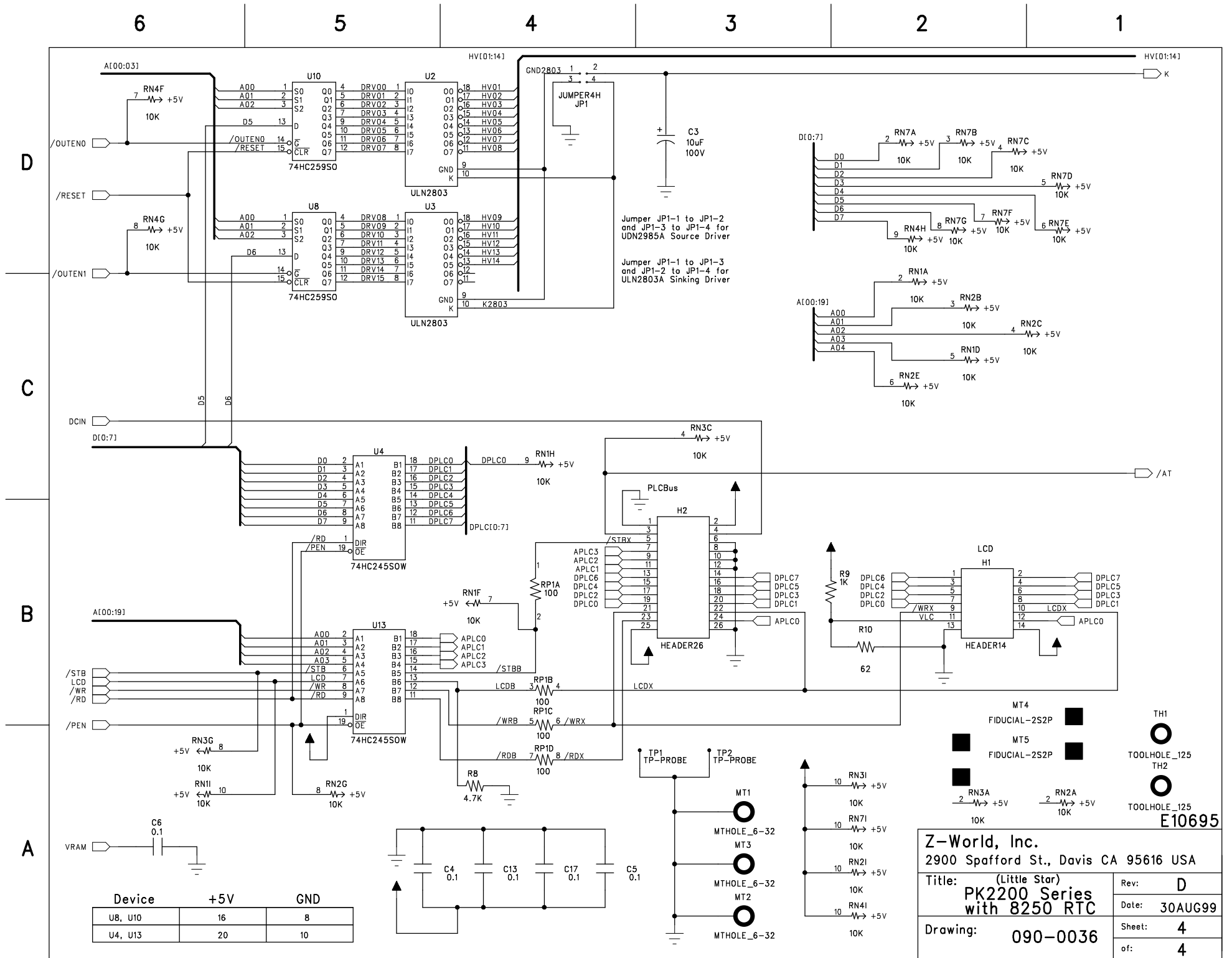

Z-World, Inc.
 2900 Spafford St., Davis CA 95616 USA

Title: (Little Star)
 PK2200 Series
 with 8250 RTC

Rev: D
 Date: 30AUG99
 Sheet: 4
 of: 4

Drawing: 090-0036

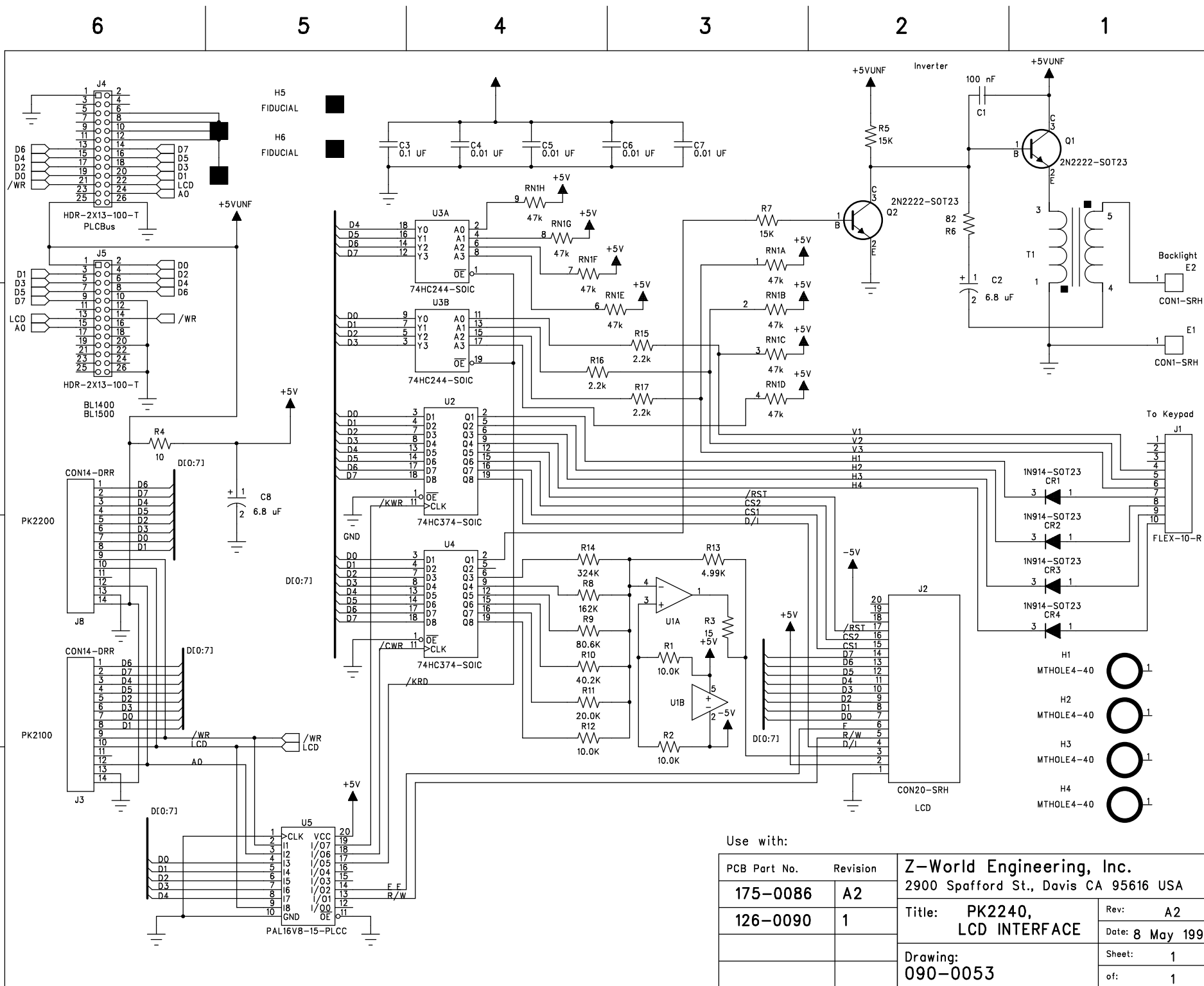

Use with:

PCB Part No.	Revision
175-0086	A2
126-0090	1

Z-World Engineering, Inc. 2900 Spafford St., Davis CA 95616 USA	
Title: PK2240, LCD INTERFACE	Rev: A2
Drawing: 090-0053	Date: 8 May 1997
	Sheet: 1
	of: 1