

10-32 Stud (Shortstop Style) Circuit Breaker

MRCBP-V Gray Body

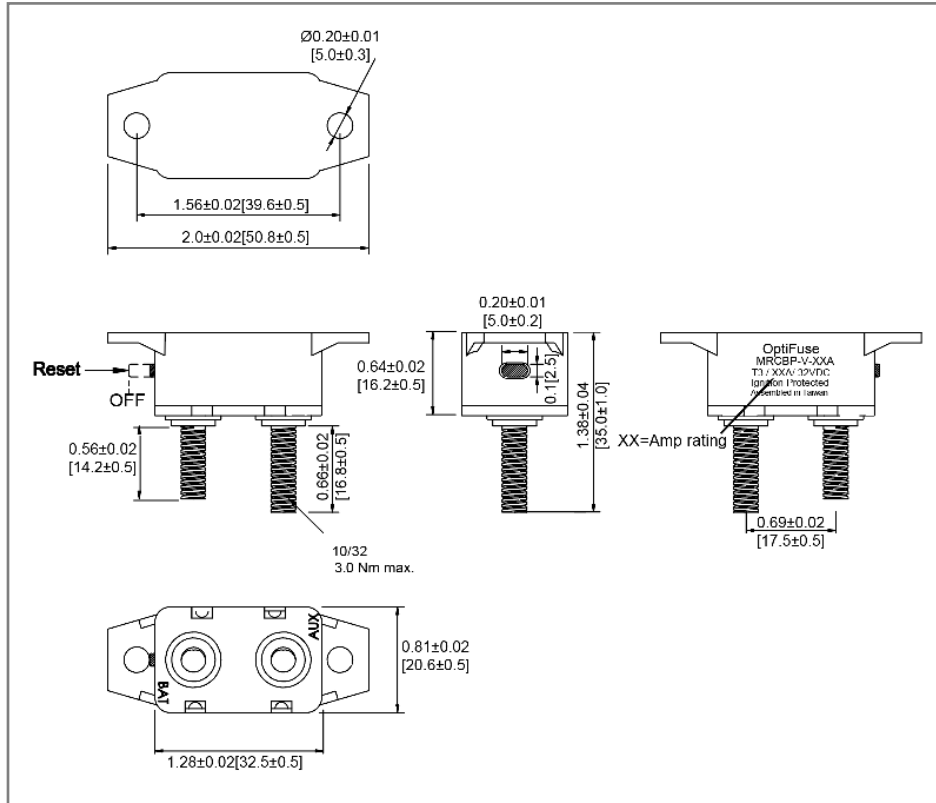

Mechanical Dimensions: Inches [mm]



Part Numbers Information

Amperage	Optifuse P/N
6A	MRCBP-V-6A
8A	MRCBP-V-8A
10A	MRCBP-V-10A
15A	MRCBP-V-15A
20A	MRCBP-V-20A
25A	MRCBP-V-25A
30A	MRCBP-V-30A
40A	MRCBP-V-40A
50A	MRCBP-V-50A

Time vs. Percent of Rated Current

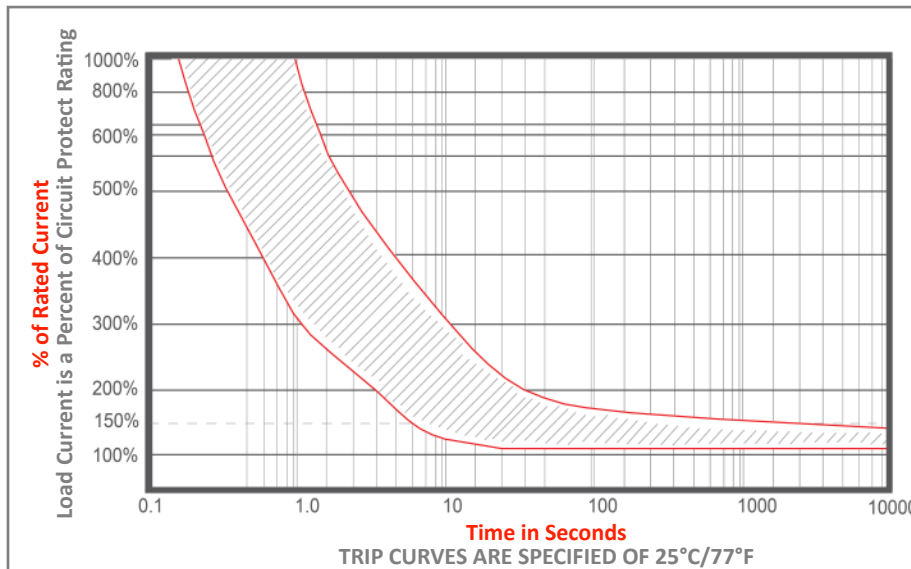

% of Rated Current	Min Trip Time	Max Trip Time
100%	Hold	No Trip
150%		Trip in 1 hr
200%	4.0s	40.0s
300%	1.2s	12.0s
400%	0.6s	5.0s
500%	0.4s	2.8s
600%	0.3s	1.8s

Electrical Specifications

Voltage Rating	12/24/32VDC
Reset Type	Type III - Manual Reset
Interrupting Rating	4 times rated current
Operation Temperature	-10°C ~ 60°C
Testing	SAE J553

Material Specifications

Body Material	Thermoplastic (UL94V-0)
Terminals Configuration	Battery – Copper Plate Auxiliary – Zinc Plate
Studs Torque	3.0 ± 0.3 N.m
Mounting Torque	1.0 ± 0.1 N.m
Ignition Protection	SAE J1171 Ingress Protection IP63

10-32 Stud (Shortstop Style) Circuit Breaker

MRCBP-V
Gray Body



Temperature Derating Curve

The time/current characteristic curve depends on the ambient temperature prevailing, In order to eliminate nuisance tripping. Please divide the current breaker current ratings by the derating factor shown below.

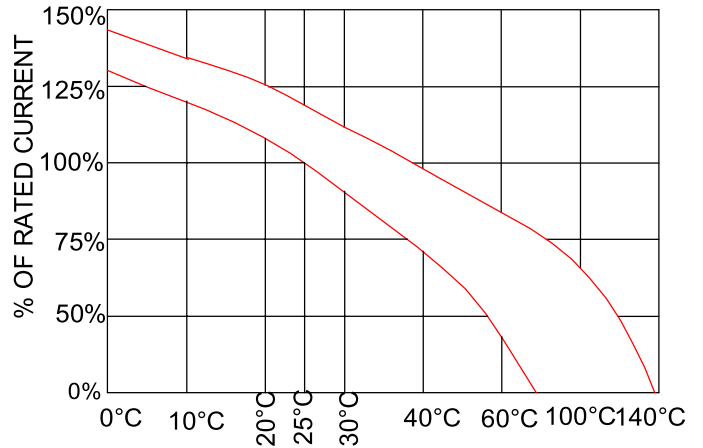

Ambient Temperature	-10°C	0°C	10°C	25°C	40°C	50°C	60°C
Division Factor	1.25	1.15	1.05	1.00	0.9	0.8	0.7

Rev **Date of issue** **Revision Notes**

Designed **Approved**

E	05-18-2023	Initial Drawing	RC	OF
---	------------	-----------------	----	----