

LOC		DIST		REVISIONS			
P	LTR	DESCRIPTION	DATE	DN	APVD		
Y		REV PER ECO-15-016251	13NOV15	KG	CD		

- 1 THIS RECEPTACLE WILL MATE WITH ANY 3C3, SIZE 2 PLUG IN AMPLIMITE SERIES.
- 2 THIS CONNECTOR ACCEPTS (3) POWER 8, OR COAX SOCKET CONTACTS IN POSITIONS A1 THRU A3, PURCHASED SEPARATELY.
- 3 STEEL PER ASTM-A-109.
- 4 BRASS PER MIL-C-50 AND ASTM-B-36 UNS NO. C26000.
- 5 FINISH: TIN PER ASTM-B-545 .000400 MIN THK OVER COPPER PER AMS2418 .000050 MIN THK.
- 6 GOLD PLATED PER MIL-G-45204 TYPE II, GRADE C, CLASS 1 OVER COPPER PER MIL-C-14550, CLASS IV.
- 7 FINISH: PLATED CADMIUM PER QQ-P-416, TYPE II, CLASS 2, OVER COPPER PER MIL-C-14550, CLASS IV.
- 8 IF CUSTOMER PART NUMBER DOES NOT FIT ON FRONT SHELL NEAR SIDE, THEN SPLIT BETWEEN FRONT AND REAR SHELL FAR SIDE.
- 9 FINISH: ZINC PLATE PER ASTM-B-633 .000200-.000400 THK WITH SUPPLEMENTARY CHROMATE (Cr3+).
- 10 MANUFACTURER'S NAME, BRAND OR LOGO AND DATE CODE MARKED ON FAR SIDE. CUSTOMER PART NO MARKED ON NEAR SIDE
- 11 MFG'S PART NUMBER MARKED ON FAR SIDE
- 12 MARK DATE CODE AND CUSTOMER PART NUMBER, FAR SIDE
- 13 MARK MFG PART NUMBER ON NEAR SIDE

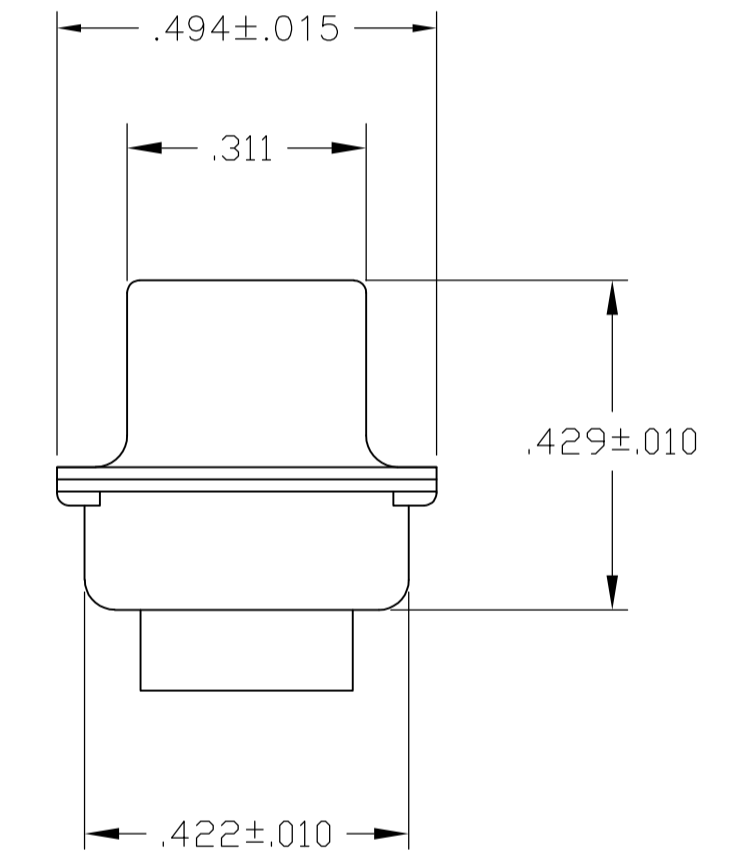
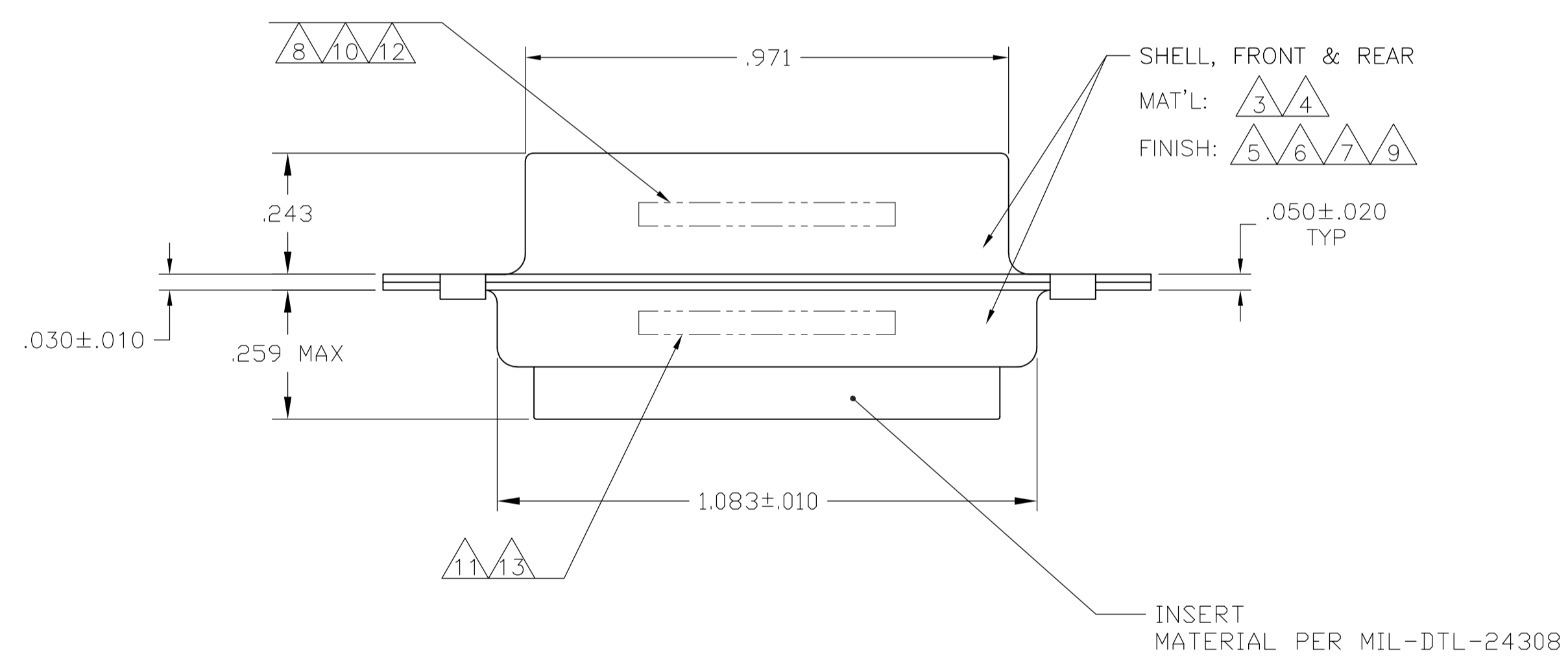
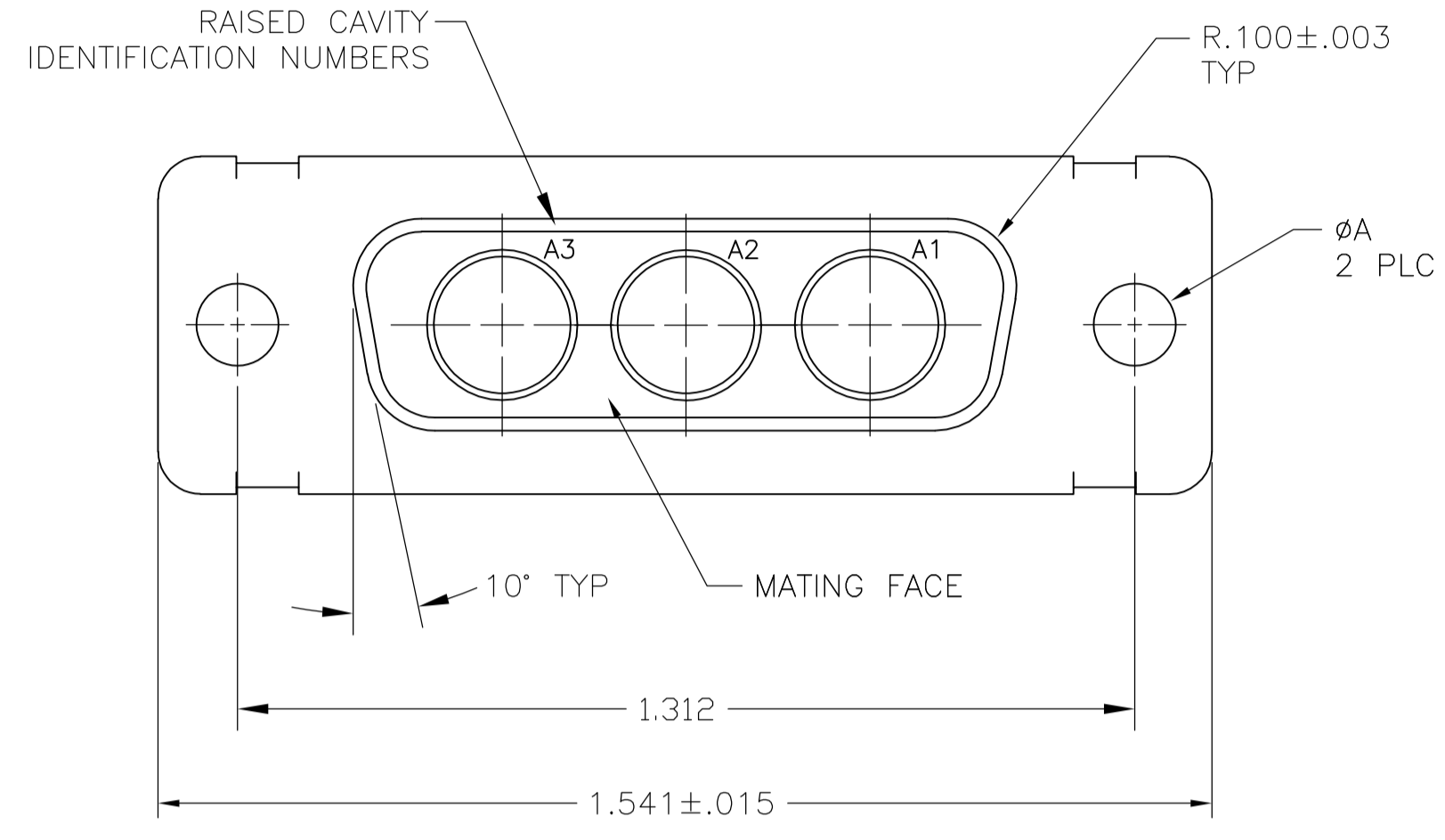

	3 9 10 11	.120	-	5-445705-4
	3 7 12 13	.120	T5935-0103-005	445705-8
	3 5 10 11	.120	-	445705-7
OBsolete	4 6 10 11	.120	A010942-0042	445705-6
	4 6 8 10 11	.120	B010942-0014	445705-5
	3 7 10 11	.120	-	445705-4
	4 6 8 10 11	.154	311P405-7S-B-15	445705-3
	4 6 8 10 11	.120	311P405-7S-B-12	445705-2
	3 5 10 11	.120	-	445705-1
REMARKS	øA	CUSTOMER PART NO.	PART NO.	

THIS DRAWING IS A CONTROLLED DOCUMENT.

DIMENSIONS: INCHES	TOLERANCES UNLESS OTHERWISE SPECIFIED:	DIN C.C.THOMAS 01NOV88	TE Connectivity
0 PLC ± -	1 PLC ± -	CIK A.FMADI 02NOV88	RECEPTACLE ASSEMBLY
2 PLC ± -	3 PLC ± .005	APVD A.FMADI 02NOV88	AMPLIMITE 3C3
4 PLC ± -	ANGLES ± 0', 30'	NAME	SIZE 2, SERIES 109, COAX MIX
MATERIAL SEE TABLE	FINISH SEE TABLE	WEIGHT	SIZE A1
			00779C=445705
		CUSTOMER DRAWING	SCALE 4:1 SHEET 1 OF 1 REV Y