

# APPROVAL SHEET

**Model No. :** UB60279-353G-WUVC01-NG-0

**Only No. :** \_\_\_\_\_

**Date :** \_\_\_\_\_

APPROVER	CHECKER	DESIGN

Please kindly make approval of our samples, And return this form by fax or airmail, Thanks for your kind attention and co-operation.

**Customer Name:** \_\_\_\_\_

**Customer Model No:** \_\_\_\_\_

CUSTOMER APPROVAL

NAC HOLDINGS LIMITED.

Tel: 86-755-23341456 Fax: 86-755-23324431

Http://www.nacoustics.com sales@nacoustics.com

**Type:** Unidirectional Back Electret Condenser Microphone

**Model Number:** UB60279-353G-WUVC01-NG-0

**1. Electrical Characteristics** (Temperature =20±2°C Humidity=65±5%)

No	Parameter	Symbol	Condition	Limits			Unit
				Min.	Center	Max.	
1.1	Sensitivity	S	0dB=1V/Pa, at 1kHz	-38	-35	-32	dB
1.2	Output impedance	Z out	f=1kHz			2.2	KΩ
1.3	Current Consumption	I <sub>DSS</sub>	V <sub>CC</sub> =2.0V,R <sub>L</sub> =2.2KΩ			500	μA
1.4	Signal to Noise Ratio	S/N	at 1kHz S.P.L=1Pa (A-Weighted Curve)	68			dB
1.5	Decreasing Voltage	ΔS	V <sub>CC</sub> =3.0V to2.0V			-3	dB
1.6	Operating Voltage			1.0		10	V
1.7	Maximum input S.P.L					110	dB
1.8	Directional Sensitivity		1kHz @ 180 degree	10			dB

**2. Typical Frequency Response Curve**

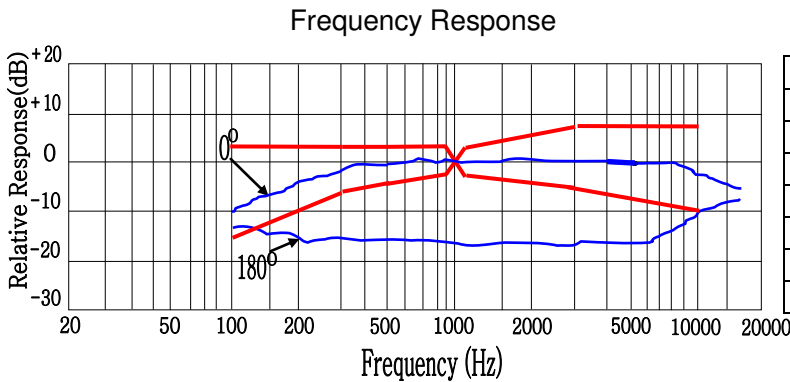

Microphone Response Tolerance Window

Frequency(Hz)	Lower Limit(dB)	Upper Limit(dB)
100	-15	+3
800	-4	+3
1000	0	0
1200	-4	+4
3000	-5	+8
5000	-6	+8
10000	-10	+8

Polar Plots

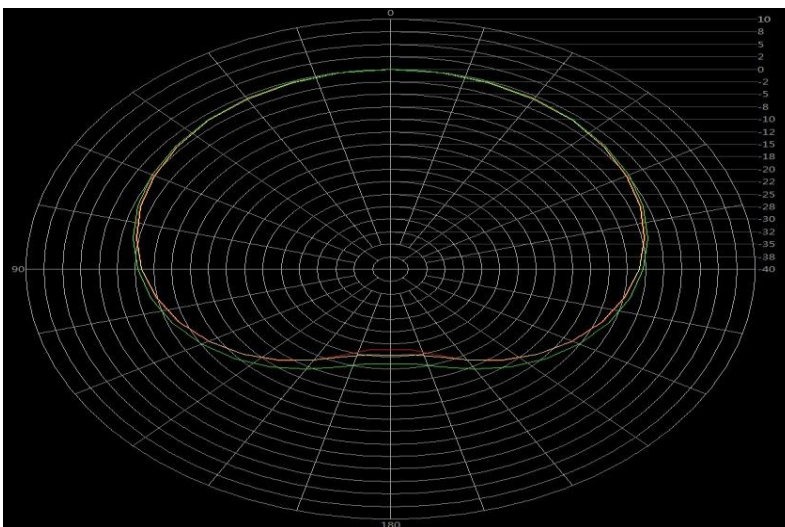

300Hz	BLUE
500Hz	GREEN
1000Hz	YELLOW
3000Hz	RED

### 3. Measurement Circuit

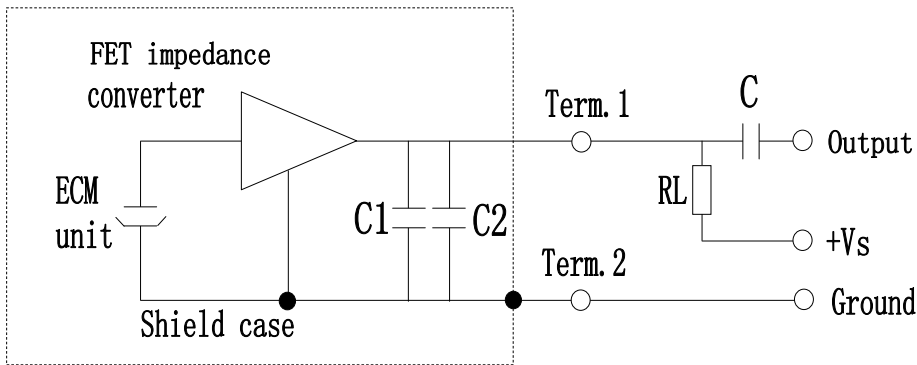

$R_L = 2.2K\Omega$
$V_S = 2.0V$
$C_1 = 10PF$
$C_2 = 33PF$
$C = 1\mu F$

### 4. Measurement Setup Drawing

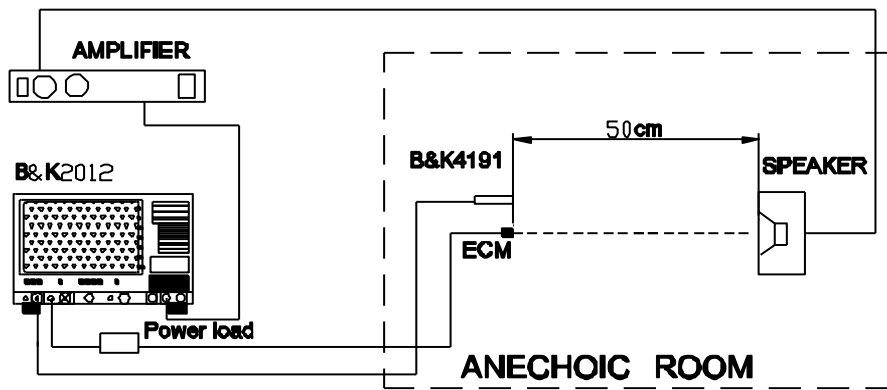

### 5. Appearance And Dimension

Unit: mm

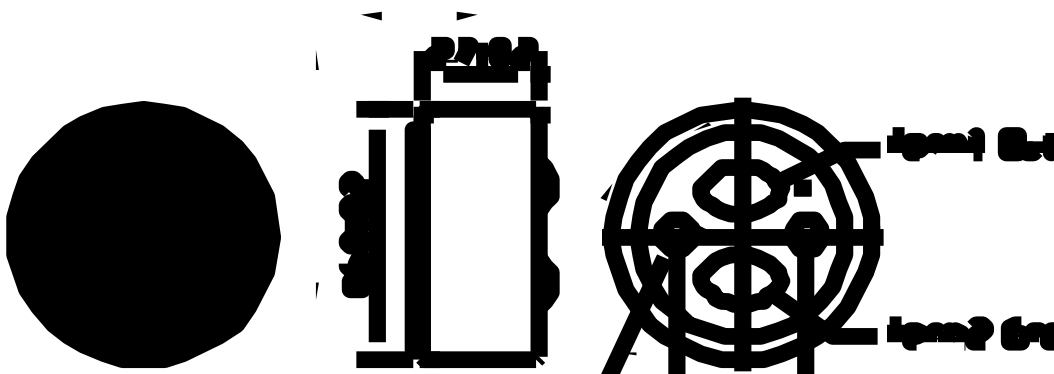

## 6. Material And Structure

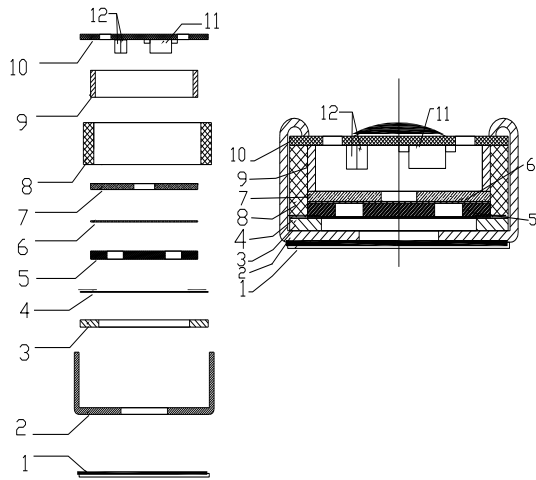

12	Capacitance	10PF+33PF	2	
11	FET		1	
10	P.C.B		1	Fr-4
9	Copper Ring		1	
8	Chamber		1	
7	One hole plate			
6	Damping		1	
5	Electret Plate			
4	Spacer		1	
3	Diaphragm		1	
2	Case	Al-Mg Alloy	1	
1	Dustproof Gauze		1	
No	Name	Material	Qty	Remark

## 7. Accessory Drawing (Unit: mm)

TOP VIEW

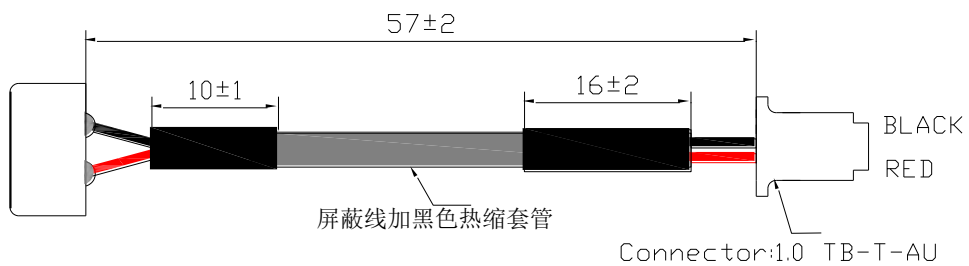

SIDE VIEW

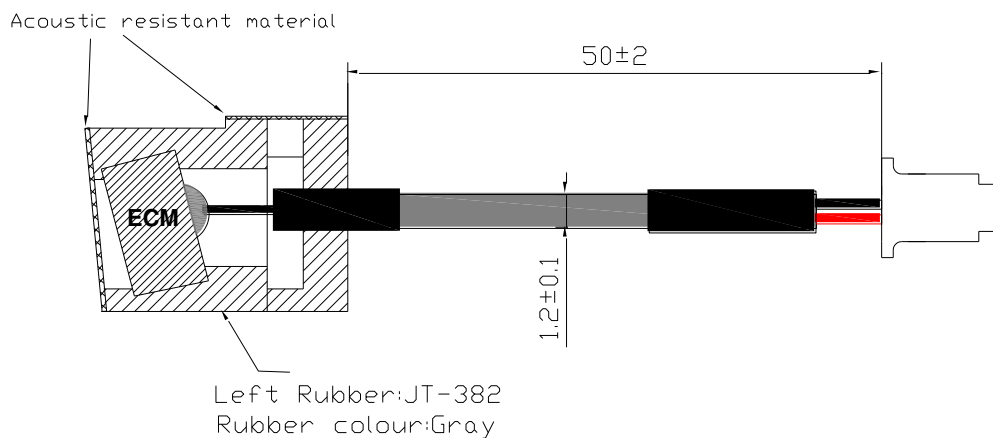

## 8. Temperature Conditions

Storage Temperature Range	Operation Temperature Range
-40°C ~ +85°C	-40°C ~ +85°C

Note: Store in electronic warehouse.

## 9. Terminal Mechanical Strength

Terminal should be no interference in operation after pulled the terminal with 1kg for 1 minute.

## 10. Reliability Test

After each of following test, the sensitivity of the microphone should be within  $\pm 3\text{dB}$  of initial sensitivity after 3hours of conditioning at 20°C.

### 1. Vibration Test

Frequency : 10Hz~55Hz  
 Amplitude : 1.52mm  
 Change of Frequency : 1 octave/min  
 2 hours in each of axes

### 2. High Temperature Test

+85°C for 240 hours.

### 3. Low Temperature Test

-40°C for 240 hours.

### 4. Humidity Test

90%~95%RH,+60°C for 240 hours.

### 5. Thermal shocking test

-40°C, 30 minutes  $\leftrightarrow$  +80°C, 30 minutes, repeated 32 cycles  $\rightarrow$  room temperature, 3 hours.

### 6. Temperature Cycles

-40°C  $\longleftrightarrow$  +20°C  $\longleftrightarrow$  +85°C  $\longleftrightarrow$  +20°C  $\longleftrightarrow$  -40°C  
 (2h) (0.5h) (2h) (0.1h) (2h) (0.5h) (2h) (0.5h) (2h) for 5 cycles.

### 7. Packing Drop Test

Height: 1.5m  
 Procedure: 5 times from each of axes

### 8. Electrostatic discharge

Tested to IEC61000-4-2 level 3:

#### a) Contact discharge

The microphone shall operate normally after 10 discharges to is 6KV DC and the discharge network is 150pF and 330Ω.

#### b) Air discharge

The microphone shall operate normally after 10 discharges to is 8KV DC and the discharge network is 150pF and 330Ω

## 11. Soldering Condition

1. We suggest using anti-static welding machine which can control soldering temperature automatically.
2. Soldering temperature should be controlled under 320°C and soldering time for each terminal should be 1~2 sec..
3. Microphone should be fixed on the metal block (heat sink), which has high radiation effects, and heat sink shall contact with MIC tightly.
4. Microphone may easily be destroyed by the static electricity and the countermeasure for eliminating the static electricity shall be executed (worktable and human body shall be ground connection)

## 5. Heat Sink

Shape of heat sink

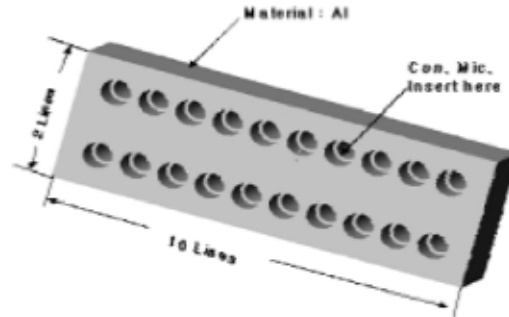

Shape of hole at fixed part

