



# TILT – 50A

## DYNAMIC INCLINOMETER

Three-Axis Accelerometer

Three-Axis Gyroscope



CTi SENSOR, INC.

Document Revision 1.3

## CTi SENSORS TECHNICAL DOCUMENT

This is our product specific technical data sheet. The following information is available to assist CTi Sensors customers in product development.

### TECHNICAL SUPPORT CONTACT INFO

Website: <http://ctisensors.com/contact-us/>

Email: [info@ctisensors.com](mailto:info@ctisensors.com)

Phone: (440) 264-2370

## TABLE OF CONTENTS

1. INTRODUCTION.....	4
1.1 FEATURES .....	4
1.2 APPLICATIONS.....	4
2. SPECIFICATIONS .....	5
2.1. ANGLES.....	5
2.2. ACCELEROMETER .....	5
2.3. GYROSCOPE .....	5
2.4. SYSTEM.....	6
2.5. MECHANICAL.....	6
3. TERMINAL ASSIGNMENT.....	7
4. WINCTI-TILT SOFTWARE.....	8
5. SERIAL INTERFACE AND DATA FORMAT.....	9
6. 8-BIT CHECKSUM .....	9
7. CONFIGURATION COMMANDS.....	10
8. DIMENSIONAL DRAWING.....	12
9. HORIZONTAL INSTALLATION POSITION.....	12
10. PART NUMBER.....	13
11. WIRED CABLES .....	14
12. REVISION HISTORY.....	15

## 1. Introduction

A **Dynamic Inclinometer** is an instrument for measuring angles of slope (or tilt), elevation or depression of an object with respect to gravity while it is not in stationary condition. As motion, vibration and shocks (external acceleration) will introduce errors in the tilt measurements, dynamic inclinometers (or tilt meters) often benefit from an on-board gyroscope and fusion algorithm which combines gyroscope and accelerometer data to rectify errors introduced by external accelerations.

The **TILT-50A** Dynamic Inclinometer series are high performance, high resolution dual axis dynamic inclinometers that use the latest miniature MEMS sensor technology.

### 1.1 Features

- Dynamic tilt measurement
- Measuring range: Pitch:  $\pm 90^\circ$ , Roll:  $\pm 180^\circ$
- Three-axis accelerometer
- Three-axis gyroscope data
- Static accuracy:  $\leq 0.15^\circ$
- Dynamic accuracy:  $\leq 1.0^\circ$  (RMS)
- High resolution:  $0.025^\circ$  |  $0.5$  mg
- Simple ASCII interface language
- IP 67 compliant connector, cable and housing
- LED heartbeat and transmission indicators
- Robust aluminum housing
- Low power consumption: 250 mW (50 mA @ 5 V)

### 1.2 Applications

- Dynamic platform alignment, and stabilization
- Vehicle control, ship, robot, automotive
- Tilt sensing and leveling
- Automotive safety systems
- Motion and position measurement
- Navigation and GPS compensation
- Robotics position sensing and control
- Agricultural and industrial vehicle tilt monitoring

## 2. Specifications

### 2.1. Angles

Table 1. Angles

Parameter	Value
Range	Pitch: $\pm 90^\circ$ , roll: $\pm 180^\circ$
Static accuracy	$\leq 0.15^\circ$ RMS (typical)
Dynamic accuracy	$\leq 1.0^\circ$ RMS (typical)
Angular resolution	$0.025^\circ$   $0.5$ mg (@ data rate $\leq 5$ )
Zero offset error	$< \pm 0.1^\circ$ (@ $20^\circ\text{C}$ )
Offset change versus temperature	$\pm 0.01^\circ/\text{C}$ (typical)
Noise density	$0.01^\circ/\sqrt{\text{Hz}}$

### 2.2. Accelerometer

Table 2. Accelerometer

Parameter	Value
Range	$\pm 2$ g/ $\pm 4$ g/ $\pm 8$ g selectable
Zero offset error	$< 1.0$ mg (@ $20^\circ\text{C}$ )
In-run bias stability	$< 10$ $\mu\text{g}$
Velocity random walk	X & Y: $0.075$ m/sec/ $\sqrt{\text{hr}}$ , Z: $0.095$ m/sec/ $\sqrt{\text{hr}}$
Nonlinearity	$\pm 0.5\%$ FS
Bias change versus temperature	$\pm 0.2$ mg/ $^\circ\text{C}$ (typical)
Noise density	$125$ $\mu\text{g}/\sqrt{\text{Hz}}$ (@ $200\text{Hz}$ )

### 2.3. Gyroscope

Table 3. Gyroscope

Parameter	Value
Range	$\pm 250/500/1000/2000$ $^\circ/\text{s}$ selectable
In-run bias stability	$< 20$ $^\circ/\text{hr}$
Angle random walk	$1.4$ $^\circ/\sqrt{\text{hr}}$
Initial bias error	$< 0.2^\circ/\text{s}$ (@ $\pm 500^\circ/\text{s}$ range)
Bias change versus temperature	X & Y: $\pm 0.02$ $^\circ/\text{s}/^\circ\text{C}$ (in-run compensated) Z: $\pm 0.01$ $^\circ/\text{s}/^\circ\text{C}$
Noise density	$0.025$ dps/ $\sqrt{\text{Hz}}$ (@ $64$ Hz)
Nonlinearity	$< 0.5\%$ FS

## 2.4. System

Table 4. System

Parameter	Value
Power source	4.1-38 VDC
Power consumption	250 mW (50 mA @ 5V)
Data format	ASCII port settings: 1 start bit, 8 data bits, 1 stop bit, no parity
Baud rate	2.4kbps – 921.6kbps selectable default: 115.2kbps
Output data rate	1, 2, 5, 10, 20, 25, 40, 50, 100 and 200 Hz selectable
GUI software	WinCTi-Tilt®
Serial interface options	RS232, RS422, RS485, UART/USB, Wireless RS485 with multi-drop networking
LED indicators	Green: CPU heartbeat, Flashing at 1 Hz Red: Data transmission rate, Flashing at current data rate
Temperature sensor resolution	1°C

## 2.5. Mechanical

Table 5. Mechanical

Parameter	Value
Protection	IP 67 (housing, connector and cable)
Dimension	1.65" x 2.15" x 1.00"
Material (cable is optional as a third-party product)	Enclosure: anodized aluminum Connector: brass/nickel Cable molded head: TPU Cable carrier: TPU or nylon Conductor insulation: PVC
Temperature range	-40°C to +85°C (-40°F to +185°F)
Connection <sup>1</sup>	Cable gland connector M8, 6-contact (female)

<sup>1</sup> For details about the cable please see section 11.

### 3. Terminal Assignment

Table 6. Terminal Assignment

Connector	Wireless	RS232/UART/USB <sup>1</sup>	RS422	RS485	Wire Color
Pin 1	+Vin	+Vin	+Vin	+Vin	Brown
Pin 2	GND	GND	GND	GND	White
Pin 3	–	TX	TX+	D+	Blue
Pin 4	–	–	TX-	D-	Black
Pin 5	–	RX	RX+	D+	Gray
Pin 6	–	–	RX-	D-	Pink

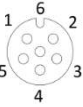
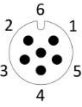

	Device: M 8 – 6-contact (female)	Cable: M 8 – 6-pin (male)	
---	-------------------------------------	------------------------------	---

<sup>1</sup> USB uses UART interface and a UART to USB cable.

### 4. WinCTi-Tilt Software

WinCTi-Tilt is a graphical user interface (GUI) software provided by CTi Sensor Inc. for visualization aid, device configuration, and data logging. WinCTi-Tilt is designed to be intuitive to users. The package can be downloaded from the CTi Sensors website.

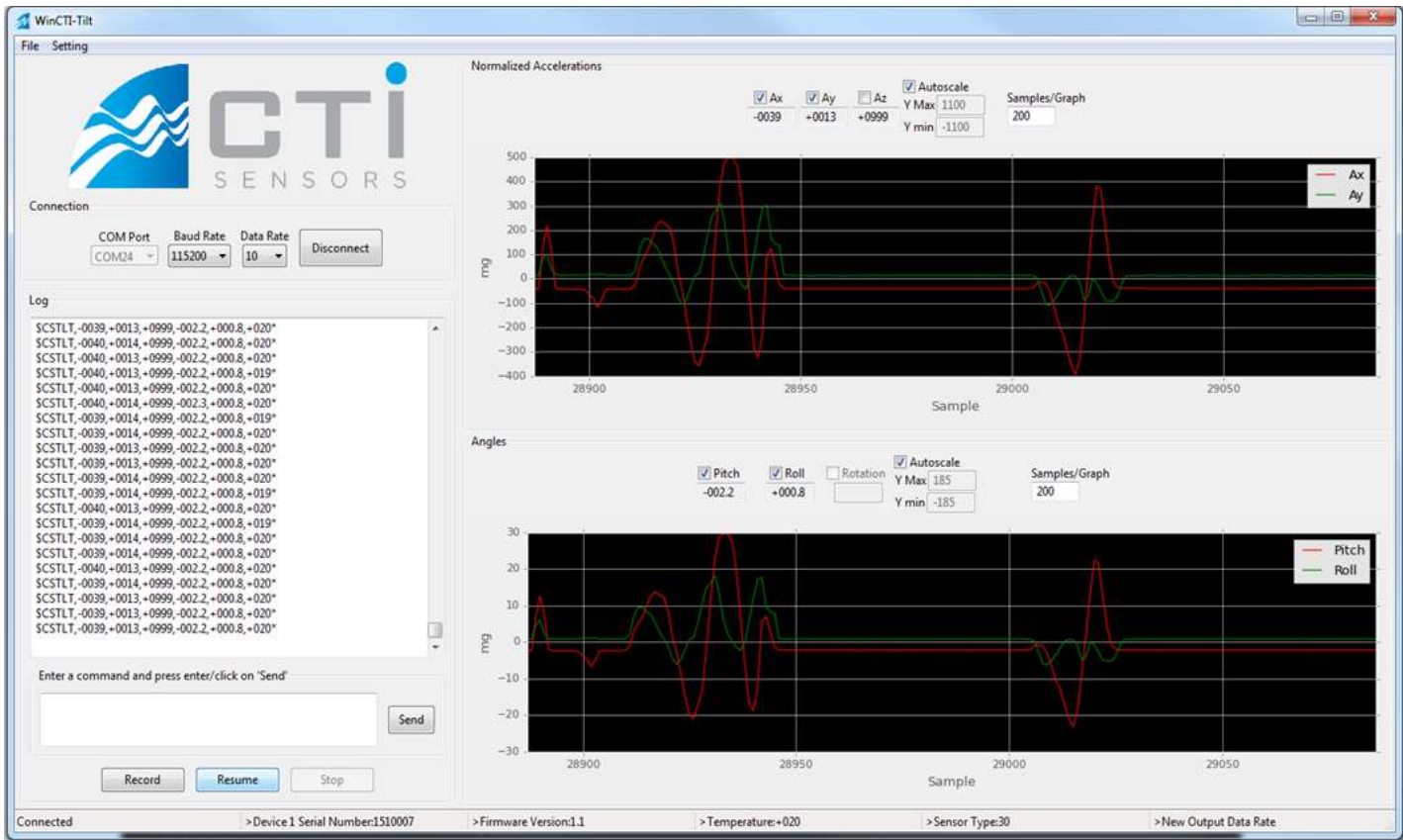



## 5. Serial Interface and Data Format

TILT-50A uses the following ASCII format, similar to the widely used NMEA 0183 protocol, for data output:

- Inclinometer message (default): \$CSTLT, A<sub>X</sub>, A<sub>Y</sub>, A<sub>Z</sub>, α<sub>X</sub>, α<sub>Y</sub>, T\*CC<CR><LF>
- Sensor data message (optional): \$CSAGD, A<sub>X</sub>, A<sub>Y</sub>, A<sub>Z</sub>, G<sub>X</sub>, G<sub>Y</sub>, G<sub>Z</sub>, T\*CC<CR><LF>

Which:

A<sub>X</sub>, A<sub>Y</sub>, A<sub>Z</sub>: X, Y and Z accelerations in milli g (three-axis accelerometer data)

G<sub>X</sub>, G<sub>Y</sub>, G<sub>Z</sub>: X, Y and Z angular velocities in deg/s (three-axis gyroscope data)

α<sub>X</sub>, α<sub>Y</sub>: Roll and pitch angles in degrees

T: Internal temperature in degree centigrade

CC: Checksum (two ASCII characters)

<CR> <LF>: Carriage return, and line feed characters

Example:

- \$CSTLT, +0010.2, -0070.6, +0990.9, +000.59, -004.07, +027\*73 Data rate < 10
- \$CSTLT, +0010, -0070, +0991, +000.58, -004.09, +027\*6E Data rate ≥ 10

## 6. 8-bit Checksum

The checksum is calculated by XORing bitwise all bytes (each character is represented by 1 byte) between the \$ and \* (not including the \$ or \* characters) based on the NMEA standard. It results in two hexadecimal characters, which are sent in ASCII format.

The code for calculating and checking the checksum is as follows:

```
unsigned char cti_checksum(unsigned char * msg)
{
    unsigned int i;
    unsigned char crc = 0;
    for (i = 0; i < strlen((char *)msg); i++)
        crc ^= msg[i];
    return crc;
}
```

## 7. Configuration Commands

The TILT-50A uses a simple command format which allows the user to change the device configuration and request specific information or data. All commands start with a '[' character, and end with a carriage return character. All responses end with a carriage return and newline character. The table below shows the list of the interface commands for the TILT-50A series.

In the table below, the lowercase 'n' represents the unit number, which is set to 1 by default, and can be set by the user to any number from 1 to 9. The lowercase letters 'm', 'x', and 'y' represent variable inputs that can be used to set the properties of the device. The lowercase letter 'd' represents variable outputs. In the commands, uppercase letters and other characters do not change.

**Table 7. Interface Commands**

Command	Comments	Response	Comments
[n<cr>	Ping unit number n	!n<cr><lf>	Acknowledge ping
[N?<cr>	Request unit number	>Unit Number: n	Returns unit number, default: n=1
[n#m<cr>	Change unit number n to (non-zero) unit number m, 1 ≤ m ≤ 9	>New Unit Number: m	n=old unit number, m=new unit number, default: n=1
[n#FW<cr>	Save unit number into flash memory	>Current Unit Number, n, was written into flash memory as the default Unit Number for this device!	Unit number will be changed permanently, and current unit number will be saved into the flash memory as the default unit number.
[nV<cr>	Firmware Version	>Firmware Version:d.dd	Returns firmware version
[nS<cr>	Serial Number	>Device n Serial Number:ddddddd	Returns 7-digit serial number
[nBxxx<cr>	Baud rate setting: xxx = 2:2400, 4:4800, 9:9600, 19:19200, 38:38400, 57:57600, 115:115200, 230:230400, 460:460800, 921:921600 (bps)	>Change to new Baud Rate:dddddd	Selected baud rate should support current data rate. Otherwise, baud rate will not be changed.
[nBFW<cr>	Save baud rate into flash memory	>Current Baud Rate, ddddd, was written into flash memory as the default Baud Rate!	Baud rate will be changed permanently, and current baud rate will be saved into the flash memory.
[nDxxx<cr>	Data rate setting: xxx = 1, 2, 5, 10, 20, 25, 40, 50, 100 and 200 Hz	>New Output Data Rate: ddd	Default data rate is 2 Hz. New data rate will be saved into the flash memory.
[nARx<cr>	Selecting accelerometer measurement range: x = ±2, ±4, ±8 g	> New Accelerometer Range: +/-d g	New accelerometer range will be saved into the flash memory (default: ±4 g).
[nGRx<cr>	Selecting gyroscope measurement range: x = 0, 1, 2, 3 0:2000, 1:1000, 2:500, 3:250 °/s	>New Gyroscope Range: +/-dddd deg/s	New gyroscope range will be saved into the flash memory (default: ±500°/s)
[nZA<cr>	Zero g offset correction for X and Y axes	>Accelerometer Zero Offset Adjusted: X Offset: ddd.d, Y Offset: ddd.d	Current values of A <sub>x</sub> and A <sub>y</sub> will be saved into the flash memory as the zero g offset.

Continued...

Command	Comments	Response	Comments
[ <u>n</u> Mxy<cr> <sup>2</sup>	Output messages ON/OFF x= I: Inclinometer data S: Sensor data (accelerometer and gyroscope) y=S: single message C: Continuous message X: Message Off	<i>Data message will be sent out once, continuously or will be turned off</i>	Example for inclinometer data: [1MIS: Sends out one inclinometer data message [1MIC: Continuously sends out inclinometer data message [1MIX: Stops sending out inclinometer data message
[ <u>n</u> MICFW<cr>	Save output message ON/OFF status into flash memory	<i>&gt;Current ON/OFF message status was written into flash memory as the default status!</i>	Current message ON/OFF status will be saved into flash memory.
[ <u>n</u> RFD<cr>	Reset to factory default (Firmware version 1.43 and higher)	<i>&gt; Reset to factory default!</i>	Resets the selectable parameters (except baud rate) to their default values.

<sup>2</sup> For RS485 interface, all messages are OFF by default.

## 8. Dimensional Drawing

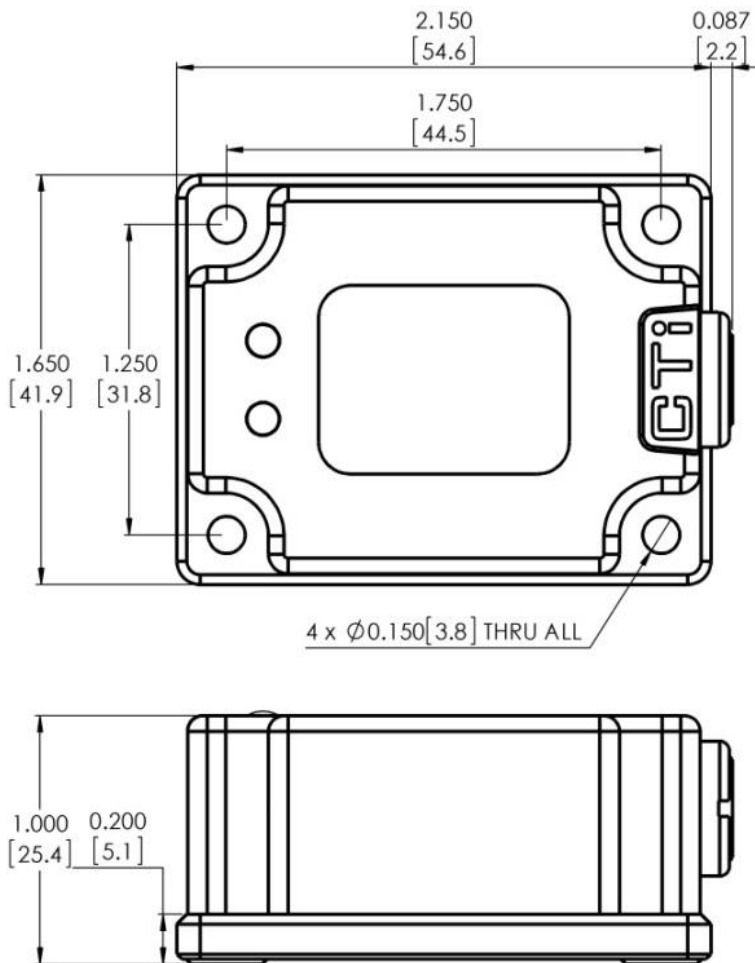

4 x Ø0.150[3.8] THRU ALL

Inch  
[millimeter]

## 9. Horizontal Installation Position

Measuring range:  $\pm 90^\circ$  (two-dimensional)

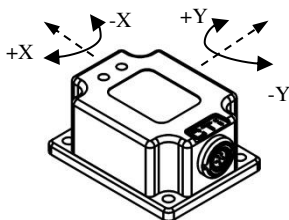

Default  
Y=0

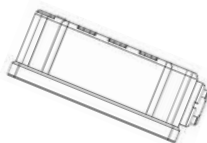

Inclination  
Y=+30

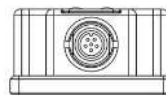

Default  
X=0



Inclination  
X=+30

## 10.Part Number

TILT – 50A – 3 – A1

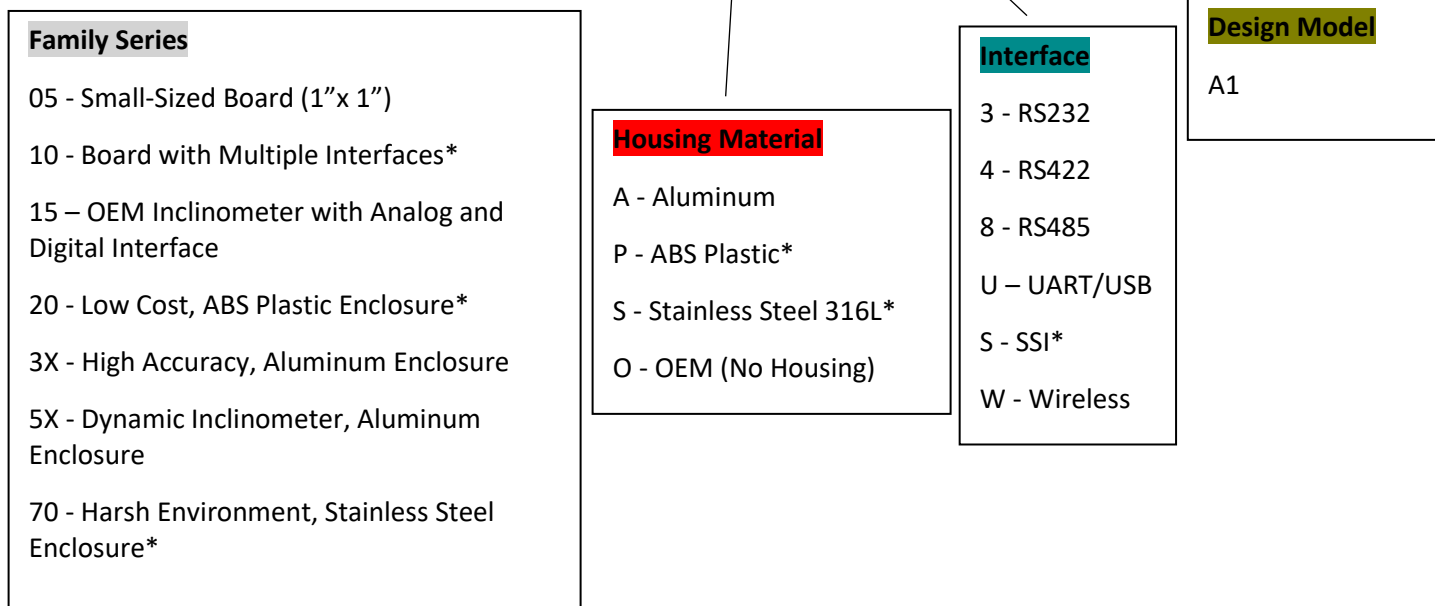

\* Product/option not available

## 11. Wired Cables<sup>1</sup>

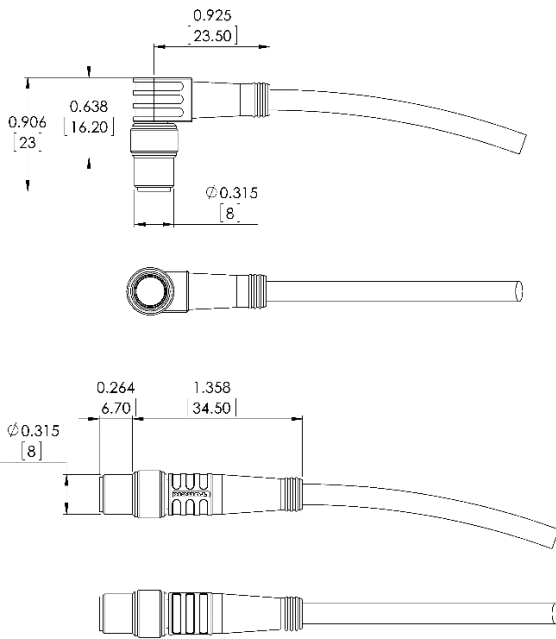
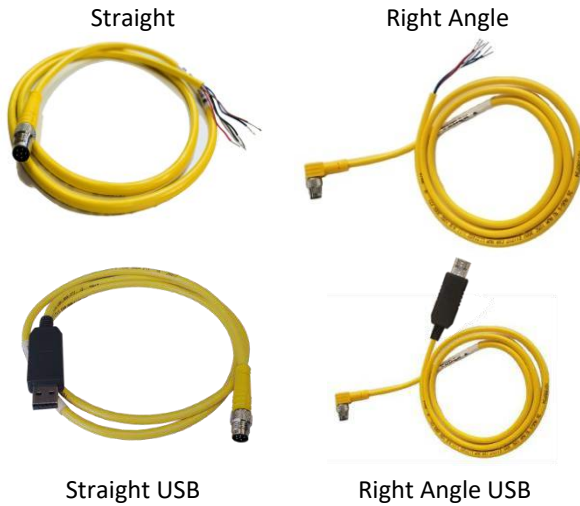

Inch

[millimeter]

### Communication Cable Part Number <sup>2</sup>

XXX XX - X - X - CS

#### Interface

G UART / RS232 / RS422 / RS485

U USB

W Wireless<sup>3</sup>

#### Length

1 meter

2 meter

3 meter

4 meter (non-stock)

5 meter (non-stock)

6 meter (non-stock)

10 meter (Only PSG)

15 meter (non-stock)

30 meter (non-stock)

#### Type

PSG 6M Straight

PSW 6M Right Angle

### Specifications

Protection	IP 67
Material	Connector: brass / nickel Cable molded head: TPU Cable carrier: TPU or nylon Conductor insulation: PVC
Operational Temperature range	-40°C to +85°C (-40°F to +185°F)
Connection	Cable gland Connector M8, 6-contact (male)

### Wireless Cables:

<https://ctisensors.com/Documents/Wireless-Datasheet.pdf>

<sup>1</sup> Cable is a third-party product.

<sup>2</sup> Available options for this model are underlined.

<sup>3</sup> Wireless module on device side has to be powered.

## 12.Revision History

Table 8. Revision History

Revision Number	Revision Date	Description of Changes
1.0	Oct. 2016	<ul style="list-style-type: none"> <li>Created document based on initial specifications</li> </ul>
1.1	Dec. 2018	<ul style="list-style-type: none"> <li>Updated document to reflect new command structure</li> </ul>
1.2	Jun. 2019	<ul style="list-style-type: none"> <li>Updated the enclosure and some specifications</li> </ul>
1.3	Sep. 2022	<ul style="list-style-type: none"> <li>Updated information and formatting</li> </ul>

**WARRANTY:** This product has 18 months limited warranty. For more information, please visit:  
[www.CTiSensors.com/warranty](http://www.CTiSensors.com/warranty)

**This product is designed and manufactured in the U.S.A.**

**CTi Sensor, Inc.**

30301 Emerald Valley Parkway, Unit B

Solon, OH 44139

Phone: (440) 264 - 2370

Email: [Sales@CTiSensors.com](mailto:Sales@CTiSensors.com)

**All contents of this document are subject to change without notice.**