

0.396±0.010  
 [.0156±.0004]  
 TYP  
 Ⓢ0.23[.009] ⓂZ Y Ⓢ

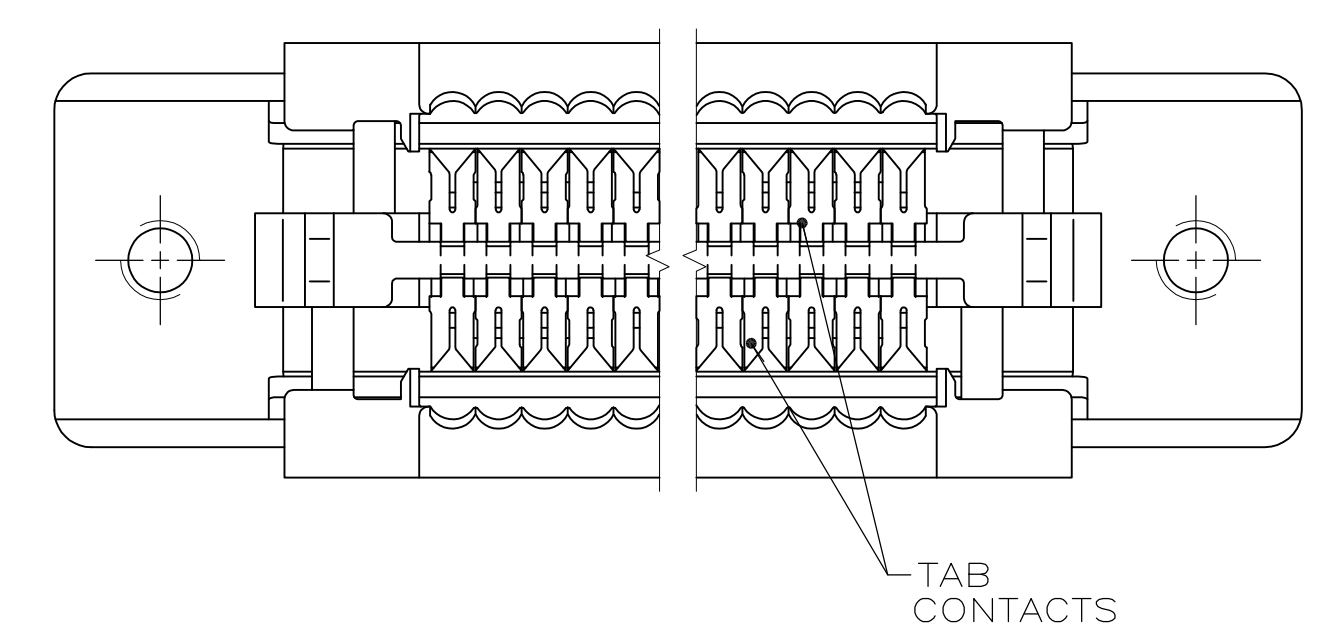
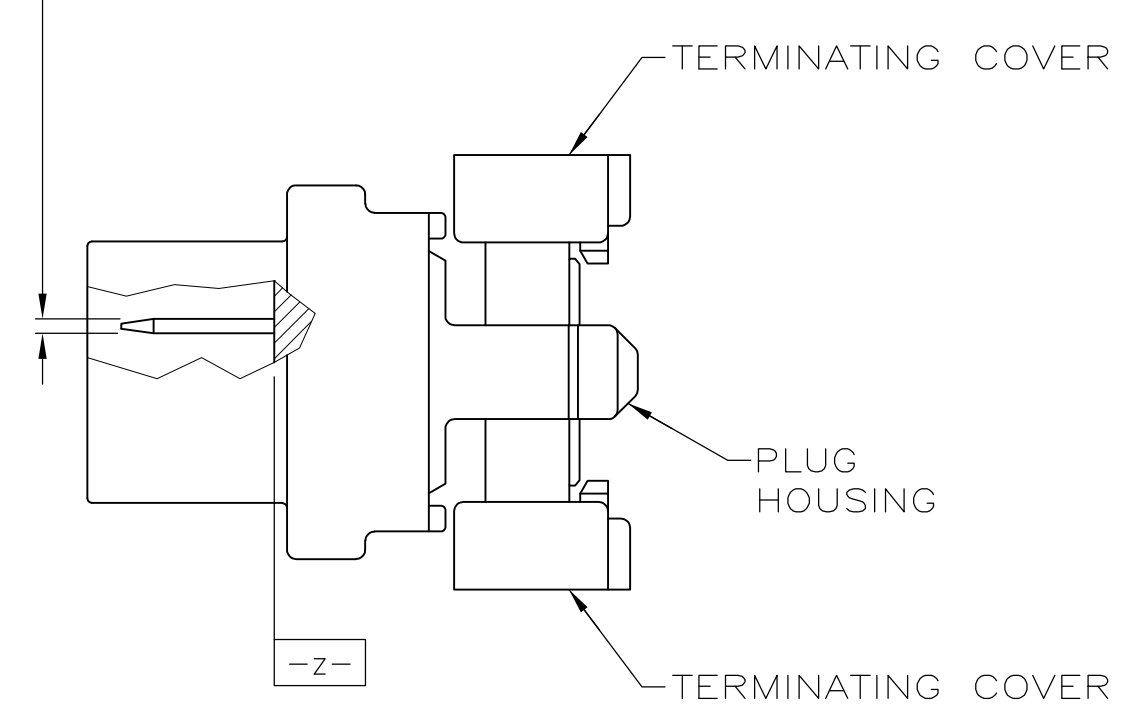

- 1 MATERIAL-  
 TAB CONTACTS: PHOSPHOR BRONZE.  
 PANEL MOUNT BRACKET: ZINC.  
 PLUG HOUSING AND TERMINATION COVERS: UL V-0 RATED THERMOPLASTIC, COLOR: BLACK.
- 2 FINISH-  
 TAB CONTACTS: EITHER 0.76µm [.000030] MINIMUM GOLD PLATE OR GOLD FLASH OVER PALLADIUM NICKEL PLATE, 0.76µm [.000030] MIN TOTAL IN CONTACT AREA, 1.27µm [.000050] MINIMUM BRIGHT TIN-LEAD PLATE IN TERMINATION AREA, ALL OVER 1.27µm [.000050] MINIMUM NICKEL UNDERPLATE.  
 PANEL MOUNT BRACKET: 5.08µm [.000200] MINIMUM NICKEL PLATE OVER 7.62µm [.000300] MINIMUM COPPER PLATE.
- 3. RECOMMENDED WIRE:  
 28 AWG OR 30 AWG, SOLID OR 7 STRANDED, PVC INSULATION WITH A 0.74-0.91 [.029-.036] INSULATION DIA.
- 4 FINISH-  
 TAB CONTACTS: EITHER 0.76µm [.000030] MINIMUM GOLD PLATE OR GOLD FLASH OVER PALLADIUM NICKEL PLATE, 0.76µm [.000030] MINIMUM TOTAL IN CONTACT AREA, 1.27µm [.000050] MINIMUM MATTE TIN PLATE IN TERMINATION AREA, ALL OVER 1.27µm [.000050] MINIMUM NICKEL UNDERPLATE.  
 PANEL MOUNT BRACKET: 5.08µm [.000200] MINIMUM NICKEL PLATE OVER 7.62µm [.000300] MINIMUM COPPER PLATE.
- 5 ROHS 2002/95/EC COMPLIANT

5	4	31.12	68.94	84.20	73.13	78.23	66.60	62.23	100	5-749879-9
		[1.225]	[2.714]	[3.315]	[2.879]	[3.080]	[2.622]	[2.450]		
5	4	15.24	37.19	52.45	41.38	46.48	34.85	30.48	50	5-749879-5
		[.600]	[1.464]	[2.065]	[1.629]	[1.830]	[1.372]	[1.200]		
2	2	31.12	68.94	84.20	73.13	78.23	66.60	62.23	100	749879-9
		[1.225]	[2.714]	[3.315]	[2.879]	[3.080]	[2.622]	[2.450]		
2	2	15.24	37.19	52.45	41.38	46.48	34.85	30.48	50	749879-5
		[.600]	[1.464]	[2.065]	[1.629]	[1.830]	[1.372]	[1.200]		
FINISH		G	F	E	D	C	B	A	NO OF POSN	PART NUMBER

THIS DRAWING IS A CONTROLLED DOCUMENT.

DIMENSIONS: MM [INCHES]	TOLERANCES UNLESS OTHERWISE SPECIFIED: 0 PLC ± - 2 PLC ± - 3 PLC ± 0.13 [005] 4 PLC ± - ANGLES ± -	PRODUCT SPEC 108-1228 APPLICATION SPEC 114-40029	DATE 08/29/89 09/05/89	NAME M. MCCAFFREY J. BROSCARD	APVD
----------------------------	---	---	------------------------------	-------------------------------------	------

MATERIAL: 1

FINISH: SEE TABLE

WEIGHT: -

CUSTOMER DRAWING

Tyco Electronics Corporation  
 Harrisburg, Pa 17105-3608

PLUG CABLE ASSEMBLY,  
 FLAT TOP, PANEL MOUNT,  
 AMPLIMITE .050 Series

SIZE: A1  
 CAGE CODE: 00779  
 DRAWING NO: 749879

SCALE: 5:1  
 SHEET: 1 OF 1  
 REV: L