

IGBT

IXSH 35N120B
IXST 35N120B

$I_{C25} = 70 \text{ A}$
 $V_{CES} = 1200 \text{ V}$
 $V_{CE(sat)} = 3.6 \text{ V}$

"S" Series - Improved SCSOA Capability

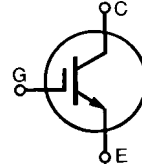

Symbol	Test Conditions	Maximum Ratings	
V_{CES}	$T_J = 25^\circ\text{C to } 150^\circ\text{C}$	1200	V
V_{CGR}	$T_J = 25^\circ\text{C to } 150^\circ\text{C}; R_{GE} = 1 \text{ M}\Omega$	1200	V
V_{GES}	Continuous	± 20	V
V_{GEM}	Transient	± 30	V
I_{C25}	$T_C = 25^\circ\text{C}$	70	A
I_{C90}	$T_C = 90^\circ\text{C}$	35	A
I_{CM}	$T_C = 25^\circ\text{C}, 1 \text{ ms}$	140	A
SSOA (RBSOA)	$V_{GE} = 15 \text{ V}, T_J = 125^\circ\text{C}, R_G = 5 \Omega$ Clamped inductive load	$I_{CM} = 90$ @ $0.8 V_{CES}$	A
t_{sc}	$T_J = 125^\circ\text{C}, V_{CE} = 720 \text{ V}; V_{GE} = 15 \text{ V}, R_G = 22 \Omega$	10	μs
P_C	$T_C = 25^\circ\text{C}$	300	W
T_J		-55 ... +150	$^\circ\text{C}$
T_{JM}		150	$^\circ\text{C}$
T_{stg}		-55 ... +150	$^\circ\text{C}$
M_d	Mounting torque (TO-247)	1.13/10	Nm/lb.in.
Maximum lead temperature for soldering 1.6 mm (0.062 in.) from case for 10 s		300	$^\circ\text{C}$
Weight	TO-247	6	g
	TO-268	4	g

TO-247 AD (IXSH)

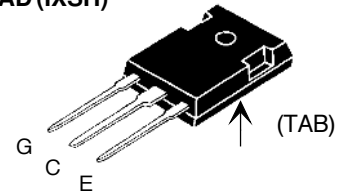

TO-268 (IXST)

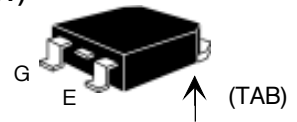

G = Gate
E = Emitter

C = Collector
TAB = Collector

Features

- Epitaxial Silicon drift region
 - fast switching
 - small tail current
- MOS gate turn-on for drive simplicity

Applications

- AC motor speed control
- DC servo and robot drives
- Uninterruptible power supplies (UPS)
- Switched-mode and resonant-mode power supplies
- DC choppers

Symbol	Test Conditions	Characteristic Values ($T_J = 25^\circ\text{C}$, unless otherwise specified)		
		min.	typ.	max.
BV_{CES}	$I_C = 1.0 \text{ mA}, V_{GE} = 0 \text{ V}$	1200		V
$V_{GE(th)}$	$I_C = 250 \mu\text{A}, V_{CE} = V_{GE}$	3		6 V
I_{CES}	$V_{CE} = 0.8 V_{CES}$ Note 1	$T_J = 25^\circ\text{C}$		50 μA
		$T_J = 125^\circ\text{C}$		2.5 mA
I_{GES}	$V_{CE} = 0 \text{ V}, V_{GE} = \pm 20 \text{ V}$			$\pm 100 \text{ nA}$
$V_{CE(sat)}$	$I_C = I_{C90}, V_{GE} = 15 \text{ V}$ Note 2	$T_J = 25^\circ\text{C}$		3.6 V
		$T_J = 125^\circ\text{C}$		2.9 V

Symbol	Test Conditions	Characteristic Values ($T_J = 25^\circ\text{C}$, unless otherwise specified)		
		min.	typ.	max.
g_{fs}	$I_C = I_{C90}; V_{CE} = 10\text{ V}$, Note 2	16	23	S
C_{ies}	$V_{CE} = 25\text{ V}, V_{GE} = 0\text{ V}, f = 1\text{ MHz}$		3600	pF
C_{oes}		260	pF	
C_{res}		75	pF	
Q_g	$I_C = I_{C90}, V_{GE} = 15\text{ V}, V_{CE} = 0.5 V_{CES}$		120	nC
Q_{ge}		33	nC	
Q_{gc}		49	nC	
$t_{d(on)}$	Inductive load, $T_J = 25^\circ\text{C}$		36	ns
t_{ri}	$I_C = I_{C90}, V_{GE} = 15\text{ V}$		27	ns
$t_{d(off)}$	$R_G = 5\ \Omega$		160	300 ns
t_{fi}	$V_{CE} = 0.8 V_{CES}$		180	300 ns
E_{off}	Note 3		5	9 mJ
$t_{d(on)}$	Inductive load, $T_J = 125^\circ\text{C}$		38	ns
t_{ri}	$I_C = I_{C90}, V_{GE} = 15\text{ V}$		29	ns
E_{on}	$R_G = 5\ \Omega, V_{CE} = 0.8 V_{CES}$		2.5	mJ
$t_{d(off)}$	Note 3		240	ns
t_{fi}			340	ns
E_{off}			9	mJ
R_{thJC}				0.42 K/W
R_{thCK}	(TO-247)		0.25	K/W

- Notes: 1. Device must be heatsunk for high temperature leakage current measurements to avoid thermal runaway.
2. Pulse test, $t \leq 300\ \mu\text{s}$, duty cycle $\leq 2\%$
3. Switching times may increase for V_{CE} (Clamp) $> 0.8 V_{CES}$, higher T_J or increased R_G .

TO-247 AD Outline (IXSH)

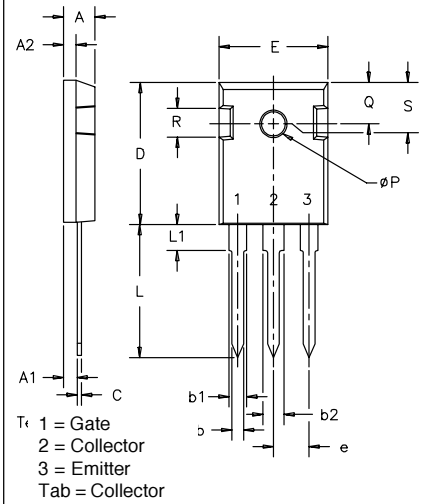

SYM	INCHES		MILLIMETERS	
	MIN	MAX	MIN	MAX
A	.185	.209	4.7	5.3
A1	.087	.102	2.2	2.54
A2	.059	.098	2.2	2.6
b	.040	.055	1.0	1.4
b1	.065	.084	1.65	2.13
b2	.113	.123	2.87	3.12
C	.016	.031	.4	.8
D	.819	.845	20.80	21.46
E	.610	.640	15.75	16.26
e	.215 BSC		5.45 BSC	
L	.780	.800	19.81	20.32
L1	.177		4.50	
ϕP	.140	.144	3.55	3.65
Q	.212	.244	5.4	6.2
R	.170	.216	4.32	5.49
S	.242 BSC		6.15 BSC	

TO-268 Outline (IXST)

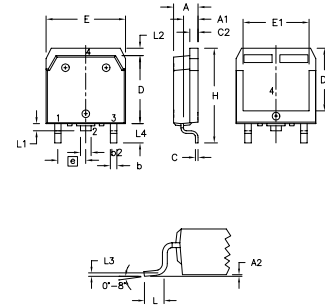

Dim.	Millimeter		Inches	
	Min.	Max.	Min.	Max.
A	4.9	5.1	.193	.201
A1	2.7	2.9	.106	.114
A2	.02	.25	.001	.010
b	1.15	1.45	.045	.057
b2	1.9	2.1	.75	.83
C	.4	.65	.016	.026
D	13.80	14.00	.543	.551
E	15.85	16.05	.624	.632
E1	13.3	13.6	.524	.535
e	5.45 BSC		.215 BSC	
H	18.70	19.10	.736	.752
L	2.40	2.70	.094	.106
L1	1.20	1.40	.047	.055
L2	1.00	1.15	.039	.045
L3	0.25 BSC		.010 BSC	
L4	3.80	4.10	.150	.161

IXYS reserves the right to change limits, test conditions, and dimensions.