

PART NAME: KNOB

SCALE: 1:1

DATE: 4/14/92

DR. BY HD



DESIGNERS & MANUFACTURERS
OF KNOBS, HANDLES, CASES &
CUSTOM PLASTIC COMPONENTS

THIS DRAWING IS THE PROPERTY OF DAVIES MOLDING COMPANY, IS SUBMITTED SOLELY AS A DESIGN OR ENGINEERING PROJECT.
WE ACCEPT NO RESPONSIBILITY WHATSOEVER FOR THE PRACTICAL APPLICATION OF THE PIECES MADE TO THIS DESIGN.

P/N 2830BG

M^{NO.} 2890-2830

CAVITY	2830
PLUNGER	2830
CAVITY PLUG	2830BG
PLUNGER PIN	2830
INNER PIN	3000-J3
OUTER PIN	3000-J
LANDING BAR	.472
PIN PLATE SHIM	.373
SHIM	.018
INSERT	10758

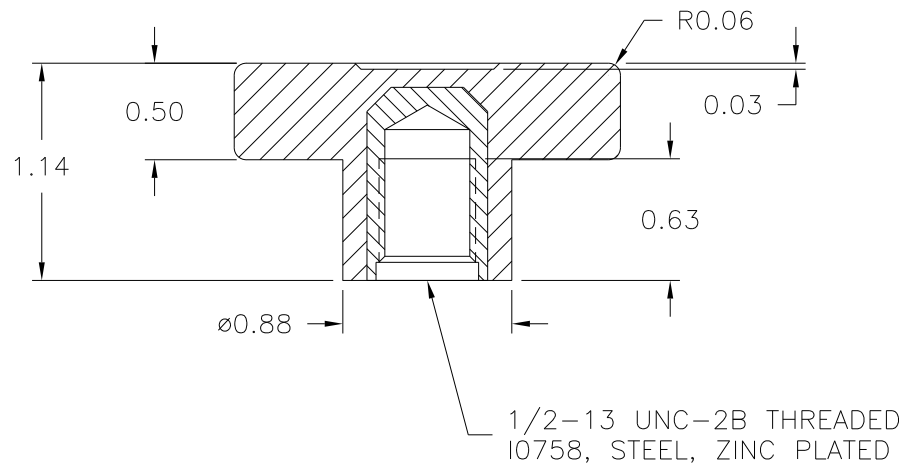
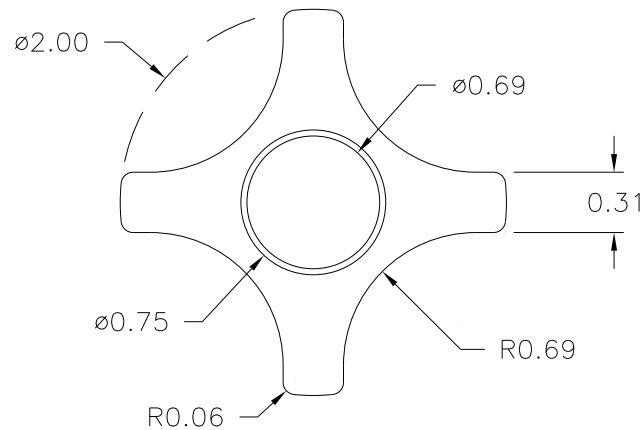

(A)

(B)(C)

MATERIAL: 02308 PHENOLIC (B08)
COLOR: BLACK

TOLERANCES: UNLESS OTHERWISE SPECIFIED	DO NOT SCALE DRAWING	C	WAS G.P. PHENOLIC (B11)	JAM	2/1/10
		B	WAS #4311	TS	5/30/01
DECIMALS: X.XXX ± .005 X.XX ± .015	MM: X.XX ± 0.15MM X.X ± 0.4MM	A	SHIM WAS .078	ST	5/14/01
		-	REDRAWN	TL	11/19/99
FRACTIONS ± 1/64	ANG. ± 1°	CHANGES			