

EVAL-M3-302F User Guide

iMOTION™ Modular Application Design Kit

About this document

Scope and purpose

This User Guide provides an overview of the evaluation board EVAL-M3-302F including its main features, key data, pin assignments and mechanical dimensions.

EVAL-M3-302F is an evaluation board as part of the iMOTION™ modular application design kit (MADK). This board features and demonstrates Infineon's advanced motion control engine (MCE 2.0) technology for permanent magnet motor drives over the full speed range.

The evaluation board EVAL-M3-302F was developed to support customers during their first steps designing applications using permanent magnet motors via sensorless sinusoidal control.

The IMC302A contains two cores – the Motion Control Engine (MCE) and an additional microcontroller (MCU). MCE support files and documentation will be available from the Infineon website. The MCU core-related CMSIS pack can be downloaded from the KEIL IDE and this document does not cover those topics.

Intended audience

This User Guide is intended for all technical specialists who have a knowledge of motor control and high-power electronics converters. The board is intended for use under laboratory conditions.

This board will be used during design in, for evaluation and measurement of characteristics, and proof of data sheet specifications.

Note: PCB and auxiliary circuits are NOT optimized for final customer design.

Table of contents

About this document	1
Table of contents	1
1 Important notice	3
2 Safety precautions	5
3 Introduction	6
4 EVAL-M3-302F main features	7
4.1 Functional description.....	8
4.2 IMC302A-F064 pinout description.....	9
4.3 EVAL-M3-302F board specifications.....	12
4.4 Pin assignment.....	13
5 Getting started with EVAL-M3-302F	17
5.1 Setting up the motion control engine (MCE).....	17
5.2 iMOTION™ development tools and software.....	19
5.2.1 MCEWizard setup overview.....	19

Table of contents

5.2.2	MCEDesigner setup overview	21
5.3	Working with the MCU.....	23
6	Hardware description of EVAL-M3-302F	24
6.1	Motor current feedback circuitry.....	24
6.1.1	Motor shunt configuration.....	24
6.1.2	Motor external current feedback configuration and calculation	24
6.1.3	Internal amplifier gain configuration	26
6.2	PFC hardware configuration	27
6.2.1	PFC topology selection	27
6.2.2	PFC external current feedback configuration and calculation	27
6.2.3	PFC current feedback configuration	28
6.2.4	AC voltage-sensing configuration.....	29
6.3	EVAL-M3-302F analog inputs and their MCEWizard setup	30
6.3.1	DC bus-sensing configuration.....	31
6.3.2	NTC shutdown value calculation and configuration	31
6.4	Schematics overview	33
6.5	PCB layout overview	33
7	Bill of materials.....	36
8	Reference.....	39
	Revision history.....	40

Important notice

1 Important notice

Attention: *The Evaluation Boards and Reference Boards as well as the information in this document are solely intended to support designers of applications in evaluating the use of products from Infineon Technologies for their intended applications.*

Environmental conditions have been considered in the design of the Evaluation Boards and Reference Boards provided by Infineon Technologies. The design of the Evaluation Boards and Reference Boards has been tested by Infineon Technologies only as described in this document. The design is not qualified in terms of safety requirements, manufacturing and operation over the entire operating temperature range or lifetime.

The Evaluation Boards and Reference Boards provided by Infineon Technologies are subject to functional testing only under typical load conditions. Evaluation Boards and Reference Boards are not subject to the same procedures as regular products regarding returned material analysis (RMA), process change notification (PCN) and product discontinuation (PD).

Evaluation Boards and Reference Boards are not commercialized products, and are solely intended for evaluation and testing purposes. In particular, they shall not be used for reliability testing or production. The Evaluation Boards and Reference Boards may therefore not comply with CE or similar standards (including but not limited to the EMC Directive 2004/EC/108 and the EMC Act) and may not fulfill other requirements of the country in which they are operated by the customer. The customer shall ensure that all Evaluation Boards and Reference Boards will be handled in a way which is compliant with the relevant requirements and standards of the country in which they are operated.

The Evaluation Boards and Reference Boards as well as the information provided in this document are addressed only to qualified and skilled technical staff, for laboratory usage, and shall be used and managed according to the terms and conditions set forth in this document and in other related documentation supplied with the respective Evaluation Board or Reference Board.

It is the responsibility of the customer's technical departments to evaluate the suitability of the Evaluation Boards and Reference Boards for the intended application, and to evaluate the completeness and correctness of the information provided in this document with respect to such application.

The customer accepts that the Evaluation Boards and Reference Boards are not intended to be used in life-endangering applications such as medical, nuclear, military, life-critical or other applications, where failure of the Evaluation Boards and Reference Boards, or any results from the use thereof, can reasonably be expected to result in personal injury.

The Evaluation Boards and Reference Boards and any information in this document is provided "as is" and Infineon Technologies disclaims any warranties, express or implied, including but not limited to warranties of non-infringement of third party rights and implied warranties of fitness for any purpose, or for merchantability.

Infineon Technologies shall not be responsible for any damages resulting from the use of the Evaluation Boards and Reference Boards and/or from any information provided in this

Important notice

document. The customer is obliged to defend, indemnify and hold Infineon Technologies harmless from and against any claims or damages arising out of or resulting from any use thereof.

Infineon Technologies reserves the right to modify this document and/or any information provided herein at any time without further notice.

Safety precautions

2 Safety precautions

Please note the following warnings regarding the hazards associated with development systems.

Table 1 Safety precautions

	<p>Warning: The DC link potential of this board is up to 1000 V_{DC}. When measuring voltage waveforms by oscilloscope, high voltage differential probes must be used. Failure to do so may result in personal injury or death.</p>
	<p>Warning: The evaluation or reference board contains DC bus capacitors which take time to discharge after removal of the main supply. Before working on the drive system, wait five minutes for capacitors to discharge to safe voltage levels. Failure to do so may result in personal injury or death. Darkened display LEDs are not an indication that capacitors have discharged to safe voltage levels.</p>
	<p>Warning: The evaluation or reference board is connected to the grid input during testing. Hence, high-voltage differential probes must be used when measuring voltage waveforms by oscilloscope. Failure to do so may result in personal injury or death. Darkened display LEDs are not an indication that capacitors have discharged to safe voltage levels.</p>
	<p>Warning: Remove or disconnect power from the drive before you disconnect or reconnect wires, or perform maintenance work. Wait five minutes after removing power to discharge the bus capacitors. Do not attempt to service the drive until the bus capacitors have discharged to zero. Failure to do so may result in personal injury or death.</p>
	<p>Caution: The heat sink and device surfaces of the evaluation or reference board may become hot during testing. Hence, necessary precautions are required while handling the board. Failure to comply may cause injury.</p>
	<p>Caution: Only personnel familiar with the drive, power electronics and associated machinery should plan, install, commission and subsequently service the system. Failure to comply may result in personal injury and/or equipment damage.</p>
	<p>Caution: The evaluation or reference board contains parts and assemblies sensitive to electrostatic discharge (ESD). Electrostatic control precautions are required when installing, testing, servicing or repairing the assembly. Component damage may result if ESD control procedures are not followed. If you are not familiar with electrostatic control procedures, refer to the applicable ESD protection handbooks and guidelines.</p>
	<p>Caution: A drive that is incorrectly applied or installed can lead to component damage or reduction in product lifetime. Wiring or application errors such as undersizing the motor, supplying an incorrect or inadequate AC supply, or excessive ambient temperatures may result in system malfunction.</p>
	<p>Caution: The evaluation or reference board is shipped with packing materials that need to be removed prior to installation. Failure to remove all packing materials that are unnecessary for system installation may result in overheating or abnormal operating conditions.</p>

3 Introduction

The EVAL-M3-302F evaluation board is a part of the iMOTION™ Modular Application Design Kit for drives (iMOTION™ MADK). In order to run a motor, the mating power board is required to interface this evaluation board.

The MADK platform is intended for use with various power stages with different control boards. These boards can easily be interfaced through the 20-pin iMOTION™ MADK M1, or the 30-pin iMOTION™ MADK M3 interface connector. This board is equipped with a 30-pin M3 connector and is intended for running a power factor correction (PFC) and single motor control in parallel.

This evaluation board is designed to give comprehensible solutions of sensorless control of permanent magnet motors over the full speed range. It provides Hall-sensor based or sensorless controls applying 3-phase and type 3 of 2-phase modulation. PC interface is via a micro-USB connector, and the on-board debugger is galvanically isolated. The PC interface provides a UART connection to the MCE as well as a serial wire debug (SWD) channel to the MCU.

The EVAL-M3-302F evaluation board is available from Infineon. The features of this board are described in the main features chapter of this document, whereas the remaining paragraphs provide information to enable the customers to copy, modify and qualify the design for production according to their own specific requirements.

Environmental conditions were considered in the design of the EVAL-M3-302F, but the board is not qualified in terms of safety requirements or manufacturing and operation over the entire operating temperature range or lifetime. The boards provided by Infineon are subject to functional testing only.

Evaluation boards are not subject to the same procedures as regular products regarding returned material analysis (RMA), process change notification (PCN) and product discontinuation (PD). Evaluation boards are intended to be used under laboratory conditions by technical specialists only.

Figure 1 shows the evaluation board EVAL-M3-302F. This document explains the features and details of this board as well as the control IC, IMC302A-F064.

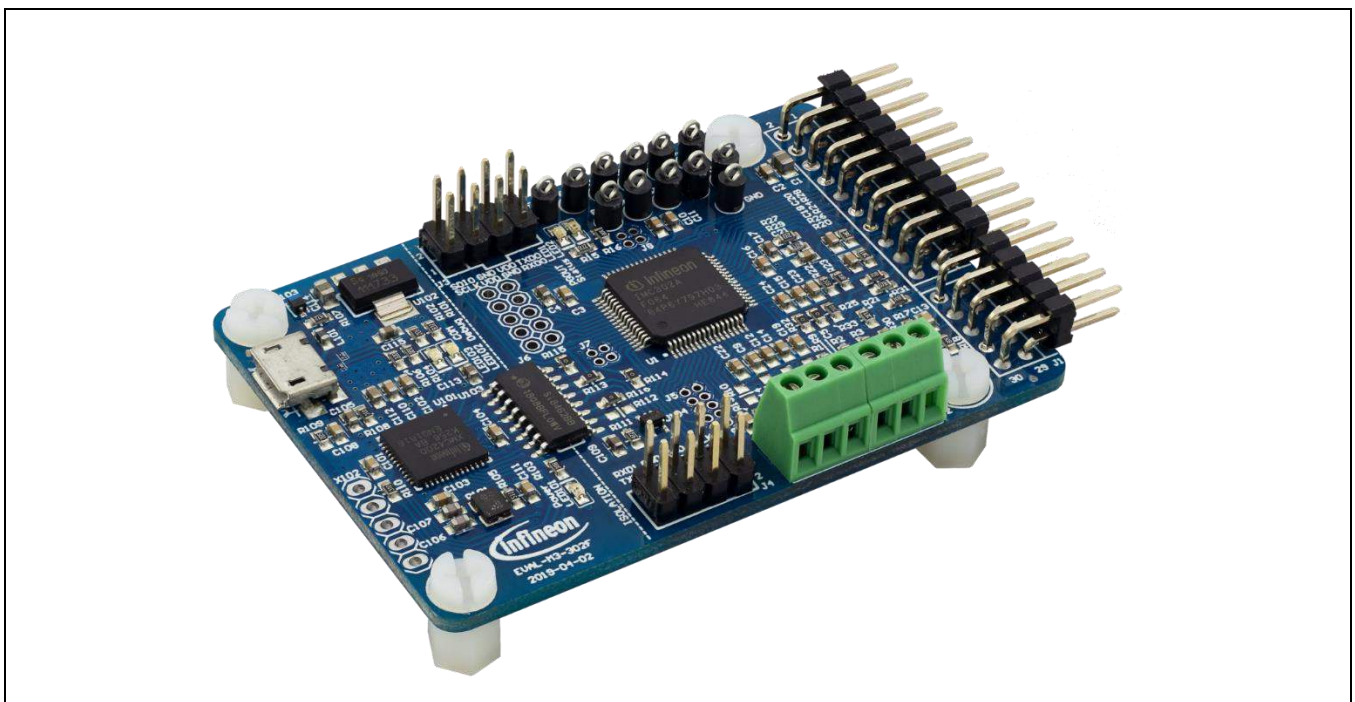

Figure 1 Evaluation board EVAL-M3-302F

4 EVAL-M3-302F main features

EVAL-M3-302F is an evaluation control board for motor control applications. The kit demonstrates Infineon's motion control IC technology.

Main features of the IMC302A-F064 motion control IC include:

- Dual core device with MCE and MCU connected via high speed serial link
- **MCE (Motion Control Engine)** as ready-to-use solution for variable speed drives
- Field-oriented control (FOC) for permanent magnet synchronous motor (PMSM)
- Space vector PWM with sinusoidal commutation and integrated protection features
- Current sensing via single or leg shunt
- Sensorless or Hall-sensor based operation
- Active boost or totem pole PFC control integrated
- Various serial communication interfaces (UART, I2C, SPI)
- Multiple motor parameter support
- Flexible host interface options for speed commands: UART, I2C, SPI, PWM or analog signal
- UL / CSA 60730 certified (Class B)
- Additional **microcontroller (MCU)** based on Arm® Cortex® M0 core
- 96/48 MHz clock, 128 /16 KByte Flash/SRAM
- RTC/ systick/ watchdog timer, fast interrupt controller
- Peripheral set targeting system control and communication
- **High-speed serial link (JCOM)** between MCE and MCU
- 3.3 V (default) or 5 V VDD power supply
- Scalable package options

The evaluation board characteristics:

- Complete kit for running any permanent magnet motor via sensorless sinusoidal control
- 3.3 V for on-board debugger is powered by USB interface and motor controller side is powered by power board
- Micro-USB connector and on-board debugger isolated by digital isolator
- Capable of 3-phase and type 3 of 2-phase modulation
- MCE and MCU run in parallel and independently from each other
- Access to MCE via virtual COM port
- Access to MCU via SWD debug channel (Segger® J-Link light)
- RoHS complaint
- PCB size is 65 x 45 mm

4.1 Functional description

Figure 2 shows a typical block diagram of a motor control application using the IMC302A-F064. The IMC302A-F064 provides a built-in, closed loop and sensorless control algorithm using the unique flexible Motion Control Engine (MCE) for permanent magnet motors, and additionally a boost or totem pole power factor correction (PFC). The MCE™ consists of a collection of control elements, motion peripherals, a dedicated motion control sequencer and internal memory to map internal signal nodes. IMC302A-F064 also employs a unique single shunt current reconstruction circuit in addition to a leg shunt current sensing circuit to eliminate additional analog/digital circuitry.

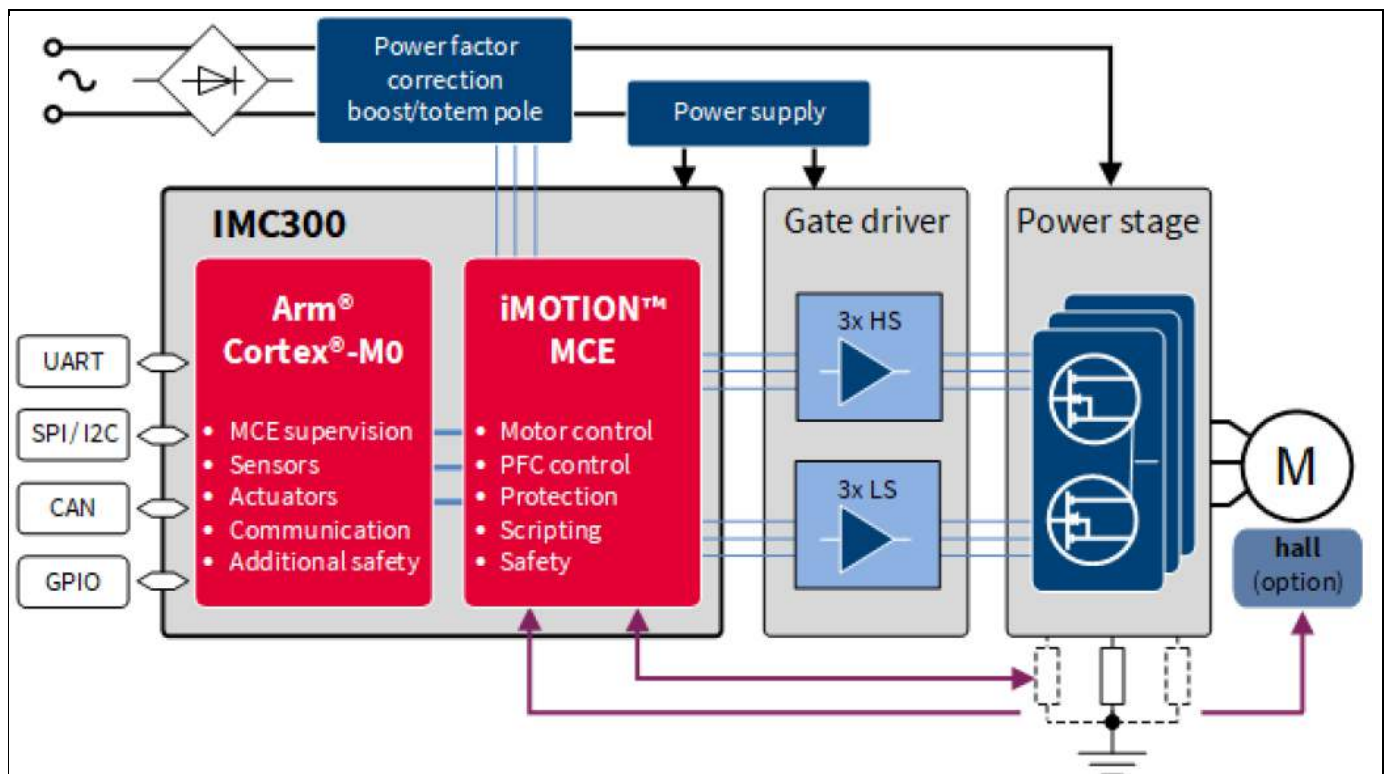

Figure 2 Typical application block diagram using IMC302A-F064

EVAL-M3-302F main features

4.2 IMC302A-F064 pinout description

The main part of the EVAL-M3-302F MADK control board is the IMC302A-F064 iMOTION™ motor control IC. Figure 3 depicts the pinout of the IMC302A-F064 IC. IMC302A-F064 comes in a 12 mm x 12 mm 64-pin LQFP package.

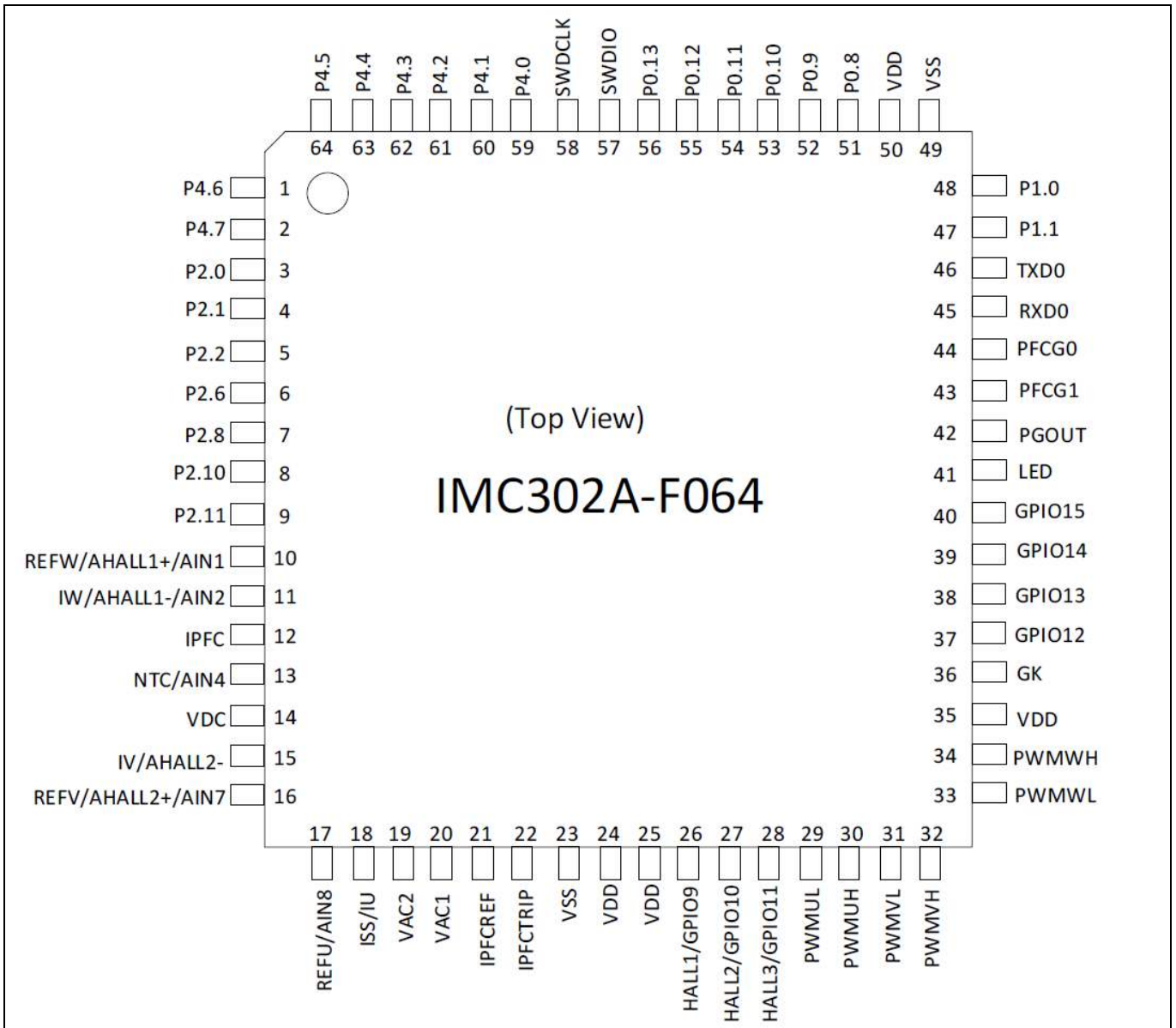

Figure 3 Pinout of IMC302A-F064

The pin type is specified as follows:

- I — digital input
- O — digital output
- AIN — analog input

EVAL-M3-302F main features

Table 2 lists the available pins of IMC302A-F064 with short descriptions. For more detailed information, please refer to the datasheet or hardware user manual for iMOTION™ IMC302A-F064 motor control IC.

Table 2 IMC302A-F064 pinout description

Pin name	Type	Pin no.	Description
VDD	Power	24,25,35,50	Supply voltage
VSS	Power	23,49	Ground
PWMUL	O	29	PWM output phase U low
PWMUH	O	30	PWM output phase U high
PWMVL	O	31	PWM output phase V low
PWMVH	O	32	PWM output phase V high
PWMWL	O	33	PWM output phase W low
PWMWH	O	34	PWM output phase W high
GK	I	36	Motor gate kill input
VDC	AIN	14	DC bus sensing input
IU/ISS	AIN	18	Current sense input single shunt / phase U
IV	AIN	15	Current sense input phase V
IW	AIN	11	Current sense input phase W
REFU	AO	17	Itrip phase U reference output
REFV	AIN	16	Itrip phase V reference output
REFW	AIN	10	Itrip phase W reference output
AHALL1+	AIN	10	Analog Hall sensor Input1+
AHALL1-	AIN	11	Analog Hall sensor Input1-
AHALL2+	AIN	16	Analog Hall sensor Input2+
AHALL2-	AIN	15	Analog Hall sensor Input2-
HALL1	IO	26	Digital Hall sensor Input1
HALL2	IO	27	Digital Hall sensor Input2
HALL3	IO	28	Digital Hall sensor Input3
PFCG0	O	44	PFC gate drive 0 output
PFCG1	O	43	PFC gate drive 1 (totem pole PFC) output
IPFC	AIN	12	PFC current sensing input
IPFCREF	AIN	21	PFC Itrip reference input
IPFCTRIP	AIN	22	PFC Itrip current sensing input
VAC1	AIN	20	AC voltage sensing input 1
VAC2	AIN	19	AC voltage sensing input 2
PGOUT	O	42	Pulse output
NTC	AIN	13	External thermistor input
LED	O	41	Status LED
RXD0	I	45	MCE UART0 receive input
TXD0	O	46	MCE UART0 transmit output

EVAL-M3-302F main features

AIN1	AIN	10	Analog input
AIN2	AIN	11	Analog input
AIN4	AIN	13	Analog input
AIN7	AIN	16	Analog input
AIN8	AIN	17	Analog input
GPIO9	IO	26	User configurable I/O, digital
GPIO10	IO	27	User configurable I/O, digital
GPIO11	IO	28	User configurable I/O, digital
GPIO12	IO	37	User configurable I/O, digital
GPIO13	IO	38	User configurable I/O, digital
GPIO14	IO	39	User configurable I/O, digital
GPIO15	IO	40	User configurable I/O, digital
P0.8	IO	51	Programmable I/O
P0.9	IO	52	Programmable I/O
P0.10	IO	53	Programmable I/O
P0.11	IO	54	Programmable I/O
P0.12	IO	55	Programmable I/O
P0.13	IO	56	Programmable I/O
P0.14/SWDIO	IO	57	Programmable I/O, or MCU SWD debug interface data input / output
P0.15/SWDCLK	I	58	Programmable I/O, or MCU SWD debug interface clock input
P1.0	IO	48	Programmable I/O
P1.1	IO	47	Programmable I/O
P2.0	IO/AIN	3	Programmable I/O, or MCU UART0 receive input, or analog input
P2.1	IO/AIN	4	Programmable I/O, or MCU UART0 transmit output, or analog input
P2.2	IO/AIN	5	Programmable I/O, or analog input
P2.6	IO/AIN	6	Programmable I/O, or analog input
P2.8	IO/AIN	7	Programmable I/O, or analog input
P2.10	IO/AIN	8	Programmable I/O, or analog input
P2.11	IO/AIN	9	Programmable I/O, or analog input
P4.0	IO	59	Programmable I/O
P4.1	IO	60	Programmable I/O
P4.2	IO	61	Programmable I/O
P4.3		62	Programmable I/O
P4.4		63	Programmable I/O, or MCU UART1 receive input
P4.5		64	Programmable I/O, or MCU UART1 transmit output

EVAL-M3-302F main features

P4.6		1	Programmable I/O
P4.7		2	Programmable I/O

4.3 EVAL-M3-302F board specifications

Table 3 depicts the key specifications of the evaluation board EVAL-M3-302F.

Table 3 EVAL-M3-302F board specifications

Parameters	Values	Conditions / comments
Host interface (not isolated)		
UART(TXD, RXD)	0 - VDD	UART0, UART0_A, UART1_A
AIN	0 - VDD	Analog input
DIN	0 - VDD	Digital input
DOUT	0 - VDD	Digital output
Input		
VDD	3.3 V (default), 5 V	Controller supply voltage
DC bus		
DC bus scaling	8.20 counts/V	13.3 kΩ resistor on control board, and 2 MΩ resistor on power board
DC bus sensing range	499.54 V max	
Current feedback		
Motor internal current feedback amplifier gain	1, 3, 6, 12	Configured by MCEWizard
Motor current sensing device	0 – VDD/Gain	Single shunt resistor Leg shunt resistor
Motor current Op-amp configuration	Non-Inverting	Default setting
Motor current external amplification gain	0.833	
PFC current sensing device	0 – VDD/Gain	
PFC current Op-amp configuration	Non-Inverting	Default setting
PFC current external amplification gain	0.923	
Resolution	12-bit	PCB design may reduce the resolution
Protections		
NTC Temperature shutdown value	0 - VDD (configured by MCEWizard)	
PCB characteristics		
Material	FR4, 1.6 mm thickness Copper thickness = 1 oz (35 μm)	
Dimension	65 mm x 45 mm	

4.4 Pin assignment

Key information about the connections of the EVAL-M3-302F evaluation board is described below.

Table 4 provides the pin assignments of the iMOTION™ MADK-M3 30-pin interface connector J1. This connector is the interface to the power board.

Table 4 J1- iMOTION™ MADK-M3 30-pin interface connector for control board

Pin No.	Pin	Details
1	PWMUH	3.3 V compatible logic output for high-side gate driver-Phase U
2	GND	Ground
3	PWMUL	3.3 V compatible logic output for low-side gate driver-Phase U
4	GND	Ground
5	PWMVH	3.3 V compatible logic output for high-side gate driver-Phase V
6	+3.3 V	On board 3.3 V supply
7	PWMVL	3.3 V compatible logic output for low-side gate driver-Phase V
8	+3.3 V	On board 3.3 V supply
9	PWMWH	3.3 V compatible logic output for high-side gate driver-Phase W
10	IU+	Shunt voltage phase U
11	PWMWL	3.3 V compatible logic output for low-side gate driver-Phase W
12	IU-	Ground
13	GK	Gate kill signal – active low when over current is detected
14	DCBSENSE	DC bus positive voltage, scaled in 0-3.3 V range by a voltage divider
15	VTH	Thermistor input
16	IV+	Shunt voltage phase V
17	IV-	Ground
18	IW+	Shunt voltage phase W
19	IW-	Ground
20	VCC	Defined for 15 V power supply (not used in this board)
21	PFCG0	3.3 V compatible logic output for PFC gate driver0
22	GND	Ground
23	PFCG1	3.3 V compatible logic output for PFC gate driver1
24	+3.3 V	On board 3.3 V supply
25	-	Not used
26	DCBSENSE	DC bus positive voltage, scaled in 0-3.3 V range by a voltage divider
27	VAC+	AC voltage input1 with high resistive input
28	VAC-	AC voltage input2 with high resistive input
29	-	Not used
30	IPFC-	Shunt voltage for PFC

EVAL-M3-302F main features

The EVAL-M3-302F supports the use of both digital and analog Hall sensors. Table 5 includes the details of the Hall sensor interface connector.

Table 5 J2- Hall sensor Input

Pin	Name	Pin name connectors
1	GND	Ground
2	AHAL2-	Analog Hall sensor Input2-
3	DHAL3/AHAL2+	Digital Hall sensor Input3 or analog Hall sensor Input2+
4	DHAL2/AHAL1-	Digital Hall sensor Input2 or analog Hall sensor Input1-
5	DHAL1/AHAL1+	Digital Hall sensor Input1 or analog Hall sensor Input1+
6	+3.3V	+3.3 V power supply

The IMC300 series of dual core controllers is the most flexible solution in terms of application support. A large number of pins is made available on pin headers supporting multiple customer-use cases.

Table 6, Table 7, Table 8, Table 9, Table 10 and Table 11 include the details of the respective signal pins for the embedded microcontroller (MCU). Functionality of the pins is flexible and can be assigned via the respective program running on the MCU. For details please refer to the IMC300 hardware reference manual.

Table 6 J3- MCU UART0 and SWD

Pin	Name	Pin name connectors
1	SWDCLK	User serial debug clock
2	SWDIO	User serial debug I/O
3	+3.3 V	+3.3 V power supply
4	GND	Ground
5	GND	Ground
6	+3.3 V	+3.3 V power supply
7	RXD0_A	MCU serial port, RXD
8	TXD0_A	MCU serial port, TXD

Table 7 J4- iMOTION Link

Pin	Name	Pin name connector
1	SWDCLK	User serial debug clock for MCU
2	SWDIO	User serial debug I/O for MCU
3	+3.3 V	+3.3 V power supply
4	GND	Ground
5	GND	Ground
6	+3.3 V	+3.3 V power supply
7	RXD0	Reception of UART0 for MCE
8	TXD0	Transmission of UART0 for MCE

EVAL-M3-302F main features

Table 8 J5- MCU I/O connection

Pin	Name	Pin name connector
1	P2.1	Programmable I/O, or MCU serial port 0
2	P2.2	Programmable I/O
3	P2.0	Programmable I/O, or MCU serial port 0
4	P2.6	Programmable I/O
5	P4.6	Programmable I/O
6	P2.8	Programmable I/O
7	P4.7	Programmable I/O
8	P2.10	Programmable I/O
9	GND	Ground
10	P2.11	Programmable I/O

Table 9 J6- MCU I/O connection

Pin	Name	Pin name connector
1	P1.1	Programmable I/O
2	P1.0	Programmable I/O
3	+3.3 V	+3.3 V power supply
4	GND	Ground
5	P0.13	Programmable I/O
6	P0.8	Programmable I/O
7	P0.12	Programmable I/O
8	P0.9	Programmable I/O
9	P0.11	Programmable I/O
10	P0.10	Programmable I/O

Table 10 J7- MCU I/O connection

Pin	Name	Pin name connector
1	P4.1	Programmable I/O
2	P4.2	Programmable I/O
3	P4.0	Programmable I/O
4	P4.3	Programmable I/O

Table 11 J9- MCU UART1

Pin	Name	Pin name connector
1	GND	Ground
2	+3.3 V	VDD
3	RXD1_A	MCU serial port 1, RXD
4	TXD1_A	MCU serial port 1, TXD

EVAL-M3-302F main features

The Motion Control Engine (MCE) in the IMC300 can read and drive pins directly, and it also supports scripting. Table 12 lists the MCE I/O pins that are made available. For functionality please refer to the Motion Control Engine Software Reference Manual.

Table 12 J8- MCE GPIO pins

Pin	Name	Pin name connector
1	GPIO12	User configurable I/O, digital
2	GPIO13	User configurable I/O, digital
3	GPIO15	User configurable I/O, digital
4	GPIO14	User configurable I/O, digital

5 Getting started with EVAL-M3-302F

In order to run the motor system, a combination of the iMOTION™ MADK control board (EVAL-M3-302F) and the matching MADK power board (with M3 connector) is required. The iMOTION™ software tools, MCEDesigner and MCEWizard, are also required to initially set up the system, as well as to control and fine-tune the system performance to match users' exact needs. This chapter provides more details on setting up the system and getting started with the iMOTION™ MADK development platform.

The EVAL-M3-302F consists of several functional groups, which enable an out-of-the-box, fully functional motor control system combined with additional interfaces and test points for more advanced use cases. Figure 4 shows the functional groups of the EVAL-M3-302F evaluation board.

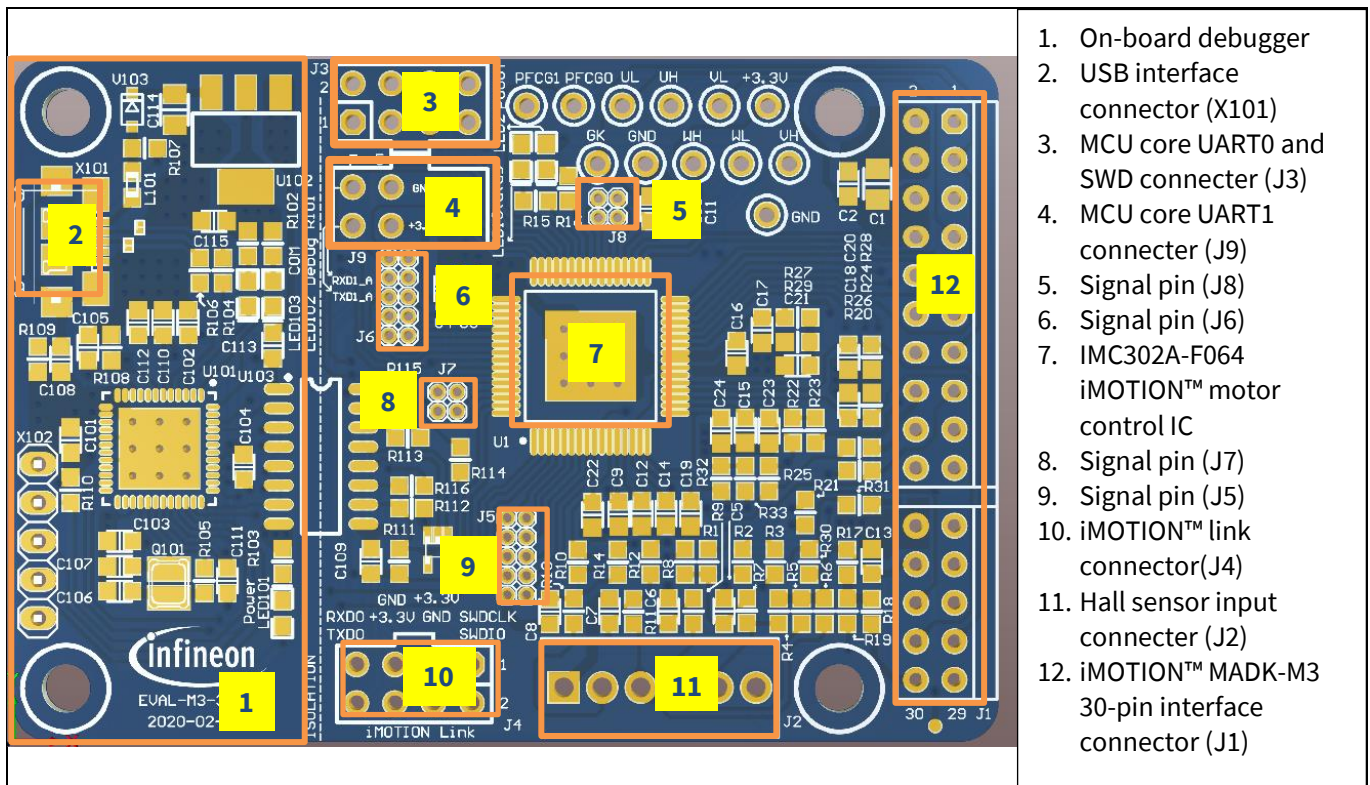

Figure 4 Functional groups of the EVAL-M3-302F evaluation board's top side

5.1 Setting up the motion control engine (MCE)

After downloading and installing the iMOTION™ PC tools (MCEWizard and MCEDesigner), the following steps need to be executed in order to run the motor. Refer to Chapters 5.2.1 and 5.2.2 as well as MCEWizard and MCEDesigner documentation for more information.

1. Get the latest IMC302A-F064 MCE software package available on www.infineon.com/imotion-software website.
2. Connect PC-USB connector on the on-board debugger to the PC via USB cable.
3. Connect EVAL-M3-302F M3 30-pin interface connector (J1) to power board (for example EVAL-M3-CM615PN, see Figure 5).
4. Use MCEWizard to enter the target motor's system and operating parameters, as well as the hardware parameters of the evaluation board, which will then be used to calculate controller's digital parameter set representing complete motor drive system. First click "Calculate" button on the "Verify & Save Page" and then save the drive parameter set into your project directory by clicking "Export to Designer file (.txt)".

Getting started with EVAL-M3-302F

Saved Drive System Parameter File will be later used by the MCEDesigner; refer to Chapter 5.2.1 or MCEWizard user guide for more details.

5. Connect motor phase outputs to the motor.
6. Connect AC power to power input connector and power on system.
7. Start MCEDesigner tool and open MCEDesigner default configuration file (.irc) for IMC302A-F064 controller (IMC302A_Vxxx.irc) by clicking “File” > “Open”. IMC302A_Vxxx.irc file is included in “IMC302A-F064 MCE Software Package” downloaded in step 1.
8. MCEDesigner should automatically connect to the EVAL-M3-302F control board using default COM port (indicated by green circle next to “COMx Up” status in the bottom frame of the MCEDesigner GUI). If it cannot establish the connection, change COM port by doing following steps: (“System” window active) > Preferences > Connection > Connect using (Chose one of the other available COM ports from the drop-down menu).
9. In case the IMC302A-F064 IC on the EVAL-M3-302F is empty (not programmed), which will be indicated by the pop-up window message after connecting to the MCEDesigner, then use following steps to program the firmware and system parameters into the internal SRAM of iMOTION™ IC: Click “Tools” > “Programmer” and select “Program Firmware and Parameters.” Browse and select the IMC302A-F064_A_Vxxx.ldf file which was included in the “IMC302A-F064 MCE Software Package” downloaded in step 1. Then browse and select the System Drive Parameters .txt file created in step 4. See chapter MCEDesigner setup overview 5.2.2 for more details.
10. In case the IMC302A-F064 IC firmware has already been loaded, use the following steps to program the system parameters into the internal SRAM of iMOTION™ IC: Click “Tools” > “Programmer” and select “Program Parameters.” Browse and select the System Drive Parameters .txt file created in step 4. See chapter MCEDesigner setup overview 5.2.2 for more details.
11. Start the motor by clicking the green traffic light button in the control bar.

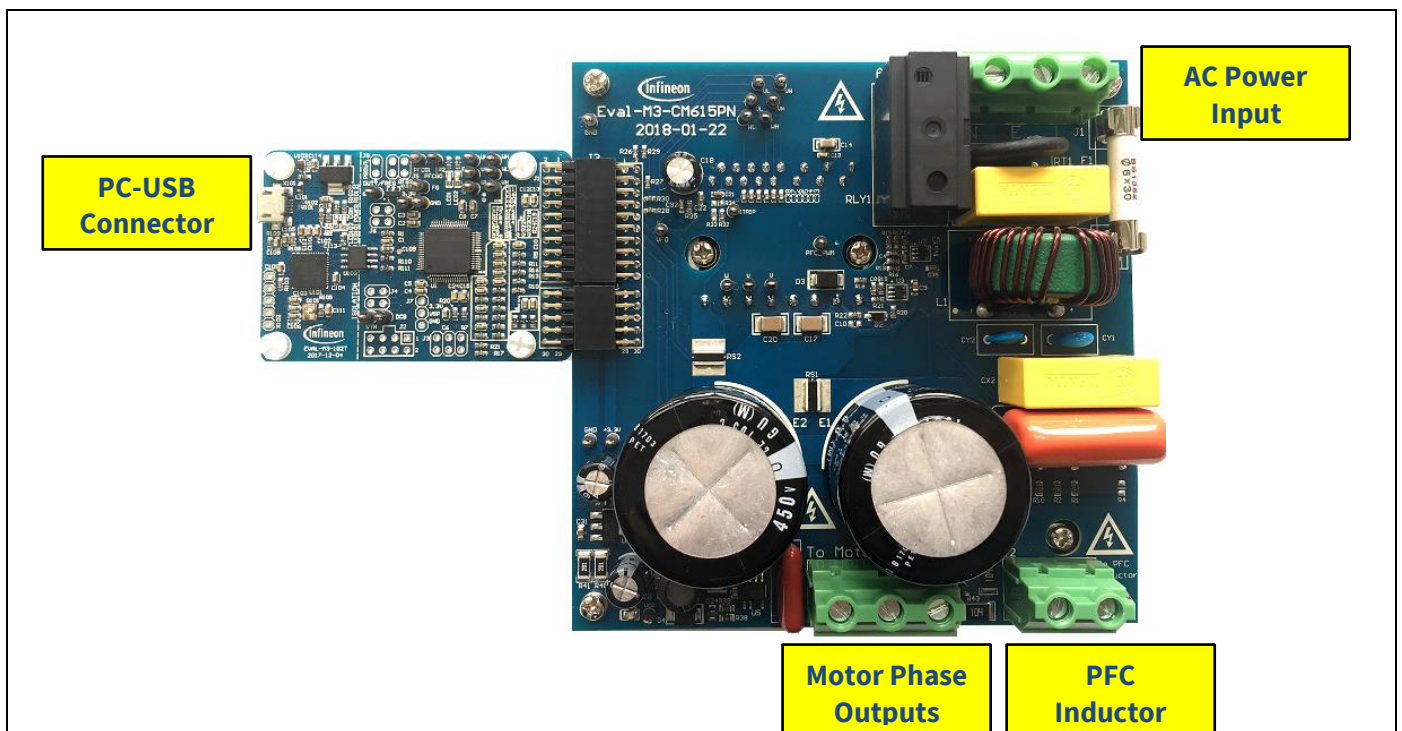

Figure 5 System connection example using EVAL-M3-302F and EVAL-M3-CM615PN

5.2 iMOTION™ development tools and software

The iMOTION™ Development Tool installers for MCEDesigner and MCEWizard are available for download via Infineon iMOTION™ website (<http://www.infineon.com/imotion-software>). All supported tools and software variants are listed there. Please visit this page periodically to check for tool/software updates.

The isolated on-board debugger provides the USB to UART bridge between the PC and the target iMOTION™ device with 1kV DC galvanic isolation between the motor drive system (hot side) and the PC/debugger (cold) side. The on-board debugger uses the SEGGER J-Link driver for UART communication with IMC302A-F064. The J-Link driver will be installed during the MCEDesigner installation. In case the driver is not installed properly, please go to [SEGGER J-Link website](#) to download and install the latest J-Link “Software and Documentation pack for Windows.”

5.2.1 MCEWizard setup overview

After installing the MCEWizard, the shortcut for MCEWizard appears on the Windows desktop. Double click the shortcut to open the MCEWizard and configure the parameters for evaluation boards or motor. Figure 6 shows the “Welcome Page” for MCEWizard, where the MADK control board or power board can be selected via the pull-down list. Infineon continues to release new MADK controller and power boards. Therefore, it could happen that some of the newest power boards are not pre-configured in the MCEWizard tool and cannot be selected in the pull-down menu. In that case, the user should select any other power board (as similar as possible) and follow the MCEWizard setup steps by entering the parameter values that are specific to the chosen board. Make sure both “I have modified the circuit board” and “Enable advanced question” checkmarks are selected. Please refer to the User Guide of the corresponding power board for additional information.

After selecting the MADK control and the power board, start the MCEWizard system setup procedure by clicking the “Next” button in the right bottom corner as shown in Figure 6.

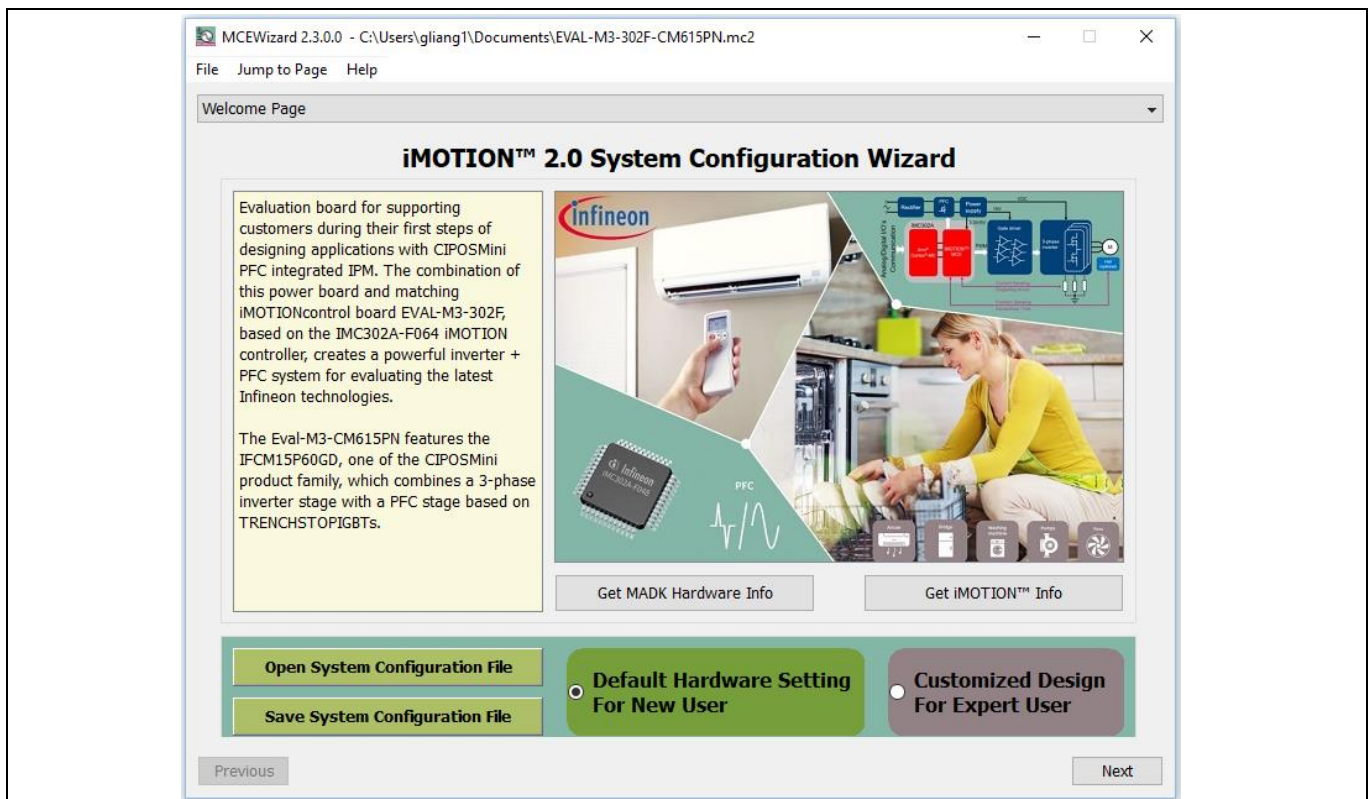

Figure 6 Welcome Page of MCEWizard

Getting started with EVAL-M3-302F

The iMOTION™ MADK system enables users to easily test different combinations of control and power boards with their motors. The user should be familiar with the system-level parameters related to the motor used. There is a very limited number of parameters that are specific to the control board or power board hardware. Table 13 provides the MCEWizard setup overview for hardware-related parameters. Similar tables will be available in the User Guide of the specific power board. Combinations of this table and the corresponding table of the power board provides sufficient information to set up the MADK-based motor drive system in the shortest time.

Table 13 MCEWizard setup overview table

Parameter	Value	Comment
Power board selecting	MADK power board name	If no, select similar power board to modify
Motor 1 shunt configuration	Refer to the power board App Note	
Controller supply voltage	Refer to the power board App Note	VDD is 3.3 V by default
Max DC bus voltage	Refer to the power board App Note	
DC bus sensing high resistor	Refer to the power board App Note	
DC bus sensing low resistor	13.3 kOhm	
NTC temperature shutdown value	Calculated as in Section 6.3.2	Refer to the power board App Note
GateSense Low-Side devices	Refer to the power board App Note	High is true by default
GateSense High-Side devices	Refer to the power board App Note	High is true by default
Motor 1 current input	Calculated as in Section 6.1.2	
PFC topology	Refer to the power board App Note	Boost or totem-pole
PFC current input	Calculated as in Section 6.2.2	
PFC gate driver polarity high side	Refer to the power board App Note	High is true by default
PFC gate driver polarity low side	Refer to the power board App Note	High is true by default

After all the MCEWizard questions are answered, the “Verify & Save Page” will be shown as in Figure 7.

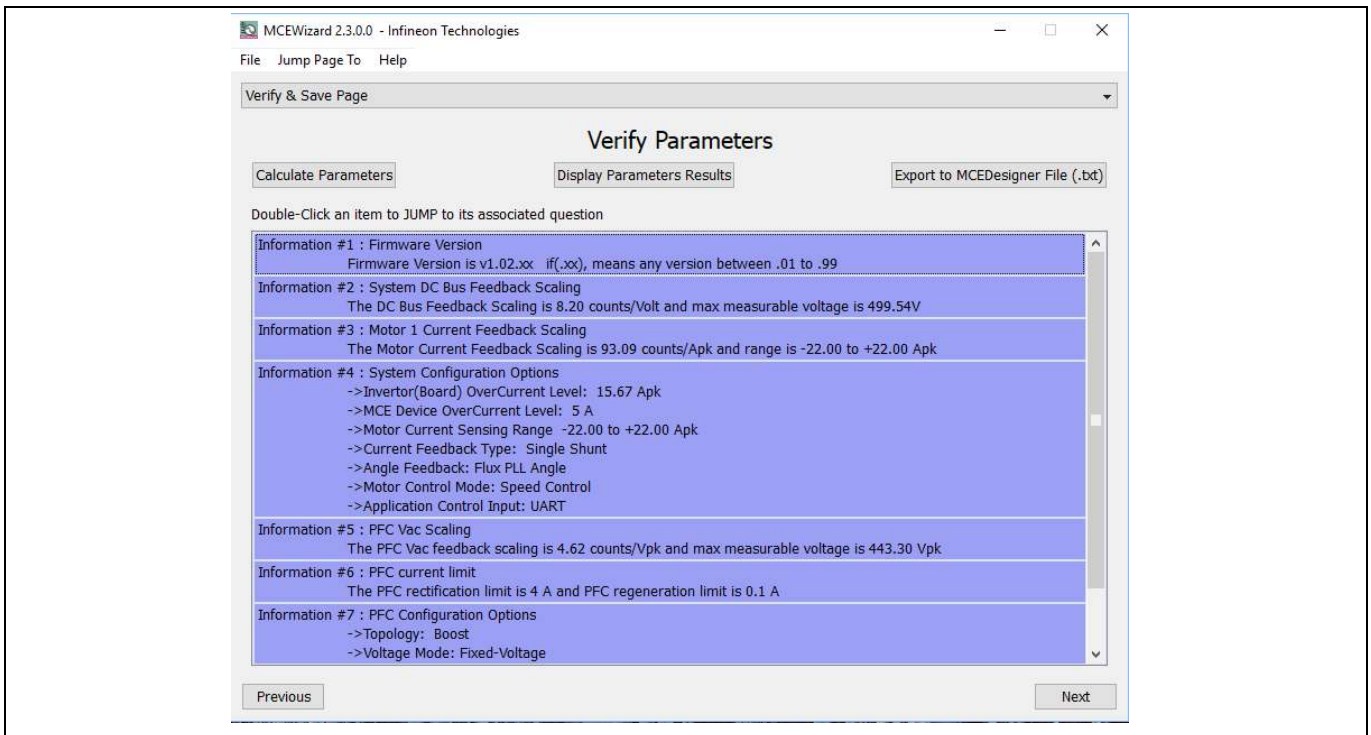

Figure 7 Verify and Save page for MCEWizard

Click “Calculate” button and “Export to Designer File (.txt)” button to save the parameter file that will be used by the MCEDesigner in the next steps.

5.2.2 MCEDesigner setup overview

After installing the MCEDesigner installer, there is a shortcut for MCEDesigner on Windows desktop. Double-click on the shortcut to open MCEDesigner and then open “IMC302A_xx.irc” file (which was included in the “IMC302A-F064 MCE Software Package” installed earlier, as instructed in Chapter 5.1) shown in Figure 8.

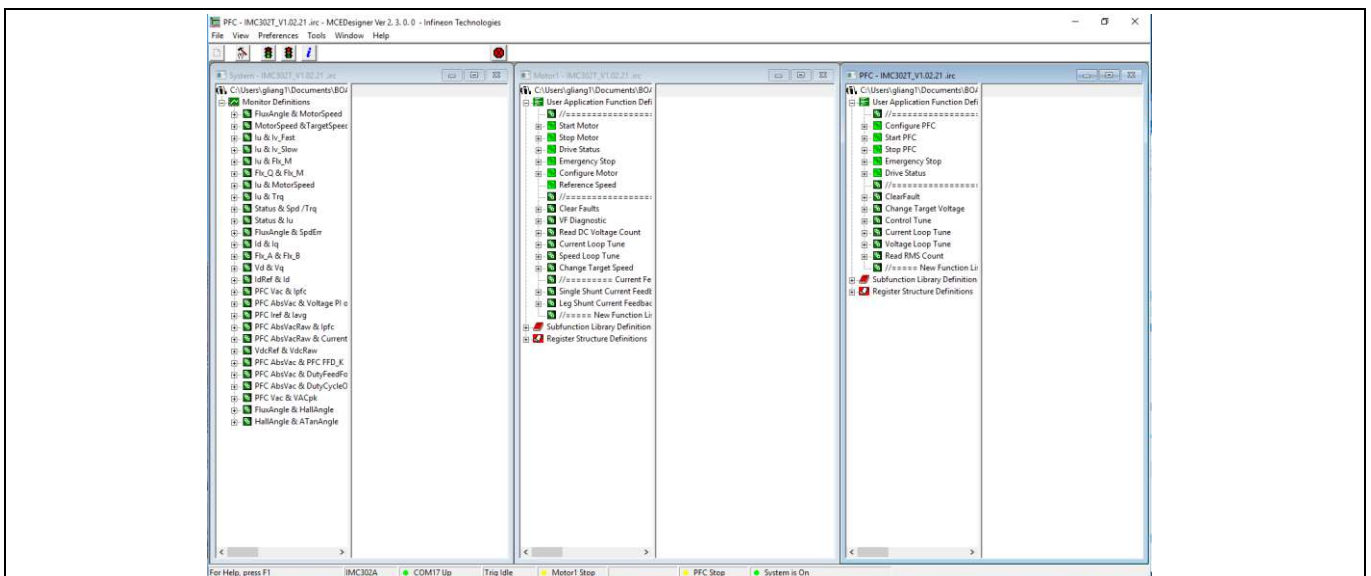

Figure 8 MCEDesigner’s main display for EVAL-M3-302F

Getting started with EVAL-M3-302F

MCEDesigner programmer function can be used to program IMC302A-F064 firmware and/or system parameters. To call up this function, click on “Tools” menu and then select “Programmer” in the pull-down list. The pop-up window “Program IMC controller” will show up as in Figure 9.

To program both firm ware and drive system parameters into IMC302A-F064 (which can happen when programming the brand new devices with default factory settings for the first time, or when the new version of iMOTION™ firmware is being downloaded), first click on the “Program Firmware and Parameter” radio button in the “Program IMC controller” pop-up window. After that, select the “Drive System Parameter” file created using MCEWizard by clicking on the “Browse...” button at the end of the “Program Parameter File” row, and then also select the IMC302A-F064_A_Vxxx.Idf file (which was included in the “IMC302A-F064 MCE Software Package”) by clicking on the “Browse...” button at the end of “Program Firmware File” row. Finally, click on the “Start” button to program the parameter file into the IMC302A-F064 IC.

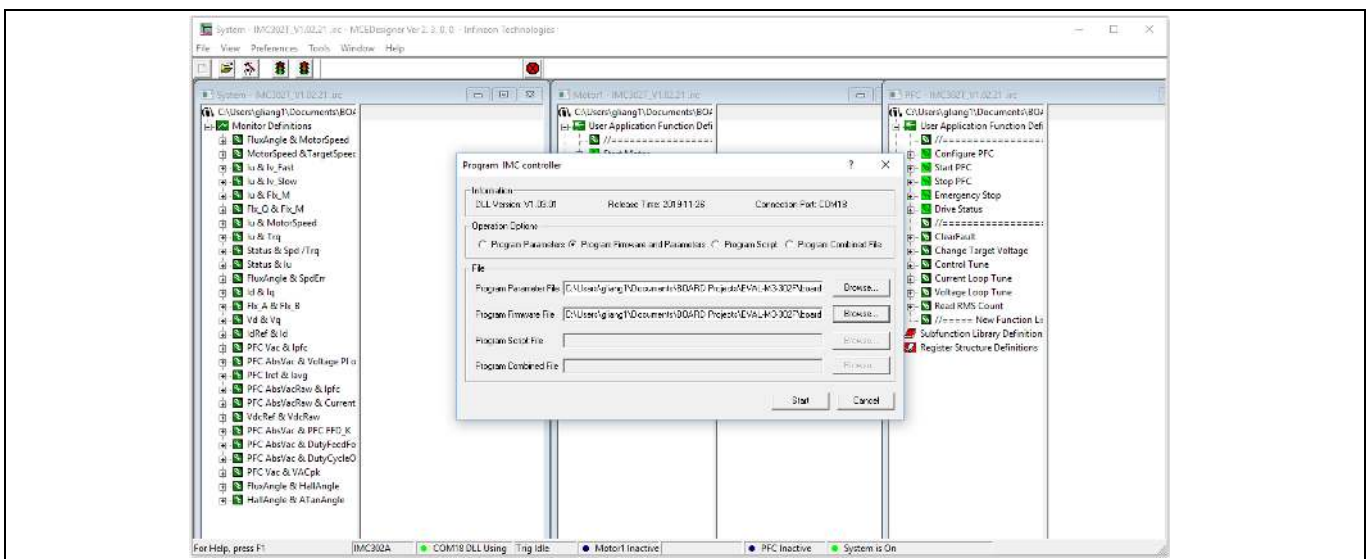

Figure 9 Program firmware and parameters in “Program IMC Controller” pop-up window

To program only “Drive System Parameter” file into IMC302A-F064, click on “Tools” menu and select “Programmer” in the pull-down list. The pop-up window “Program IMC controller” will show up as in Figure 10. Click on the “Program Parameters” button (this is the default option), and then select the “Drive System Parameter” file created using MCEWizard by clicking on “Browse...”. Finally, click on the “Start” button to program the parameter file into the IMC302A-F064 IC.

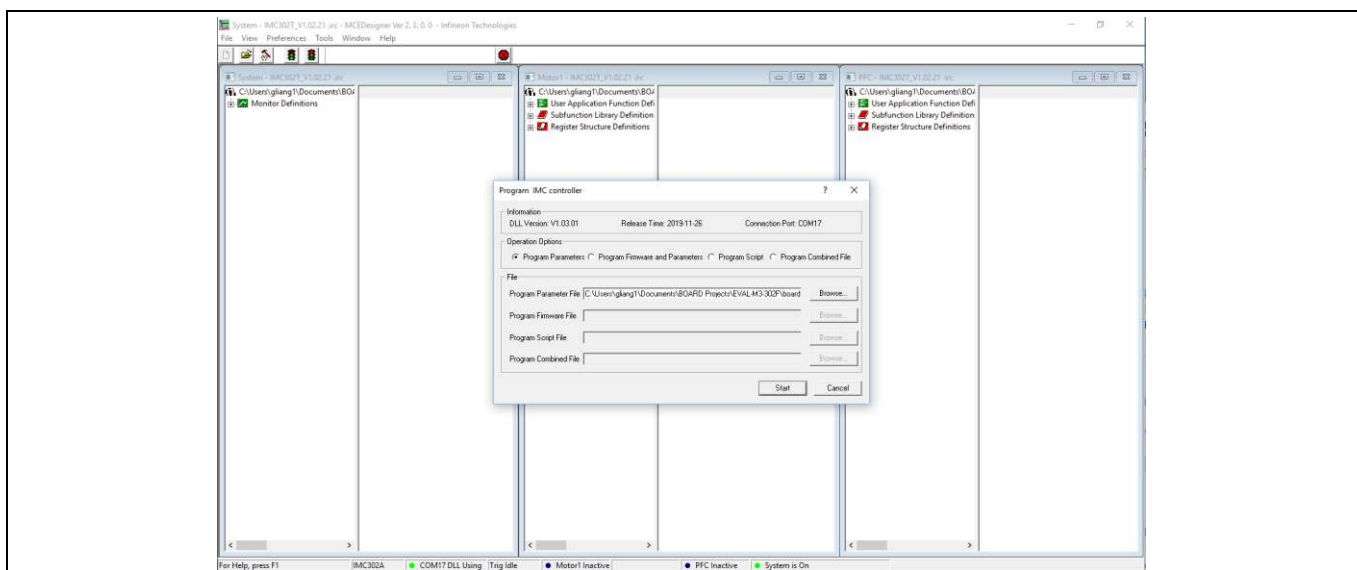

Figure 10 “Program IMC Controller” pop-up window

After “Drive System Parameter” file has been programmed into IMC302A controller, and the motor drive system is powered, the MCEDesigner can be used to start/stop the motor, display motor current traces, change the motor speed, modify drive parameters, and many other Parameters functions. Please refer to the MCEDesigner documentation for more details.

Note: The on-board debugger section of EVAL-M3-302F is galvanically isolated from the controller section and the attached power board. In order to program the parameters or firmware to the IMC302A-F064 controller, the 3.3 V DC voltage needs to be supplied to the controller portion of the EVAL-M3-302F. This voltage can either be supplied by the power board (MADK power boards are designed to supply the 3.3 V to the control board through M1 or M3 connector) or by feeding the 3.3 V DC voltage to the control board through some of the available 3.3 V access/test points, if the power board is not attached to the EVAL-M3-302F control board.

All the latest firmware files for different types of iMOTION™ control ICs are available for download via Infineon iMOTION™ website (<http://www.infineon.com/imotion-software>).

5.3 Working with the MCU

The microcontroller in the IMC302A-F064 is based on an Arm® Cortex® M0 core allowing the use of a wide range of development tools and available software solutions.

Connection to the MCU is offered via the standard serial wire debug (SWD). The SWD interface is routed via the galvanic isolation to the on-board interface. The debug interface is based on Segger® J-Link technology. The respective DLL is installed on the PC during installation of the above-mentioned iMOTION tools, namely the MCEDesigner. Alternatively, the installation of the respective driver can be updated from the Segger website.

Configuring, setting up and programming the embedded MCU is beyond the scope of this User Guide. Please refer to the Hardware Reference Manual of the IMC300 series and the CMSIS pack.

6 Hardware description of EVAL-M3-302F

This chapter covers the hardware design of the EVAL-M3-302F in more detail. To enable users to make the EVAL-M3-302F evaluation board a basis for a new development or modification of their own systems, all necessary technical data such as schematics, layout and components are also included in this chapter.

6.1 Motor current feedback circuitry

6.1.1 Motor shunt configuration

Both single shunt and leg shunt topologies are supported by the EVAL-M3-302F control board. The user needs to ensure that the shunt configuration matches the power board hardware configuration. Please refer to the power board User Guide for details. The shunt configuration can be changed in MCEWizard by clicking and selecting in the pull-down list marked with a red box as shown in Figure 11.

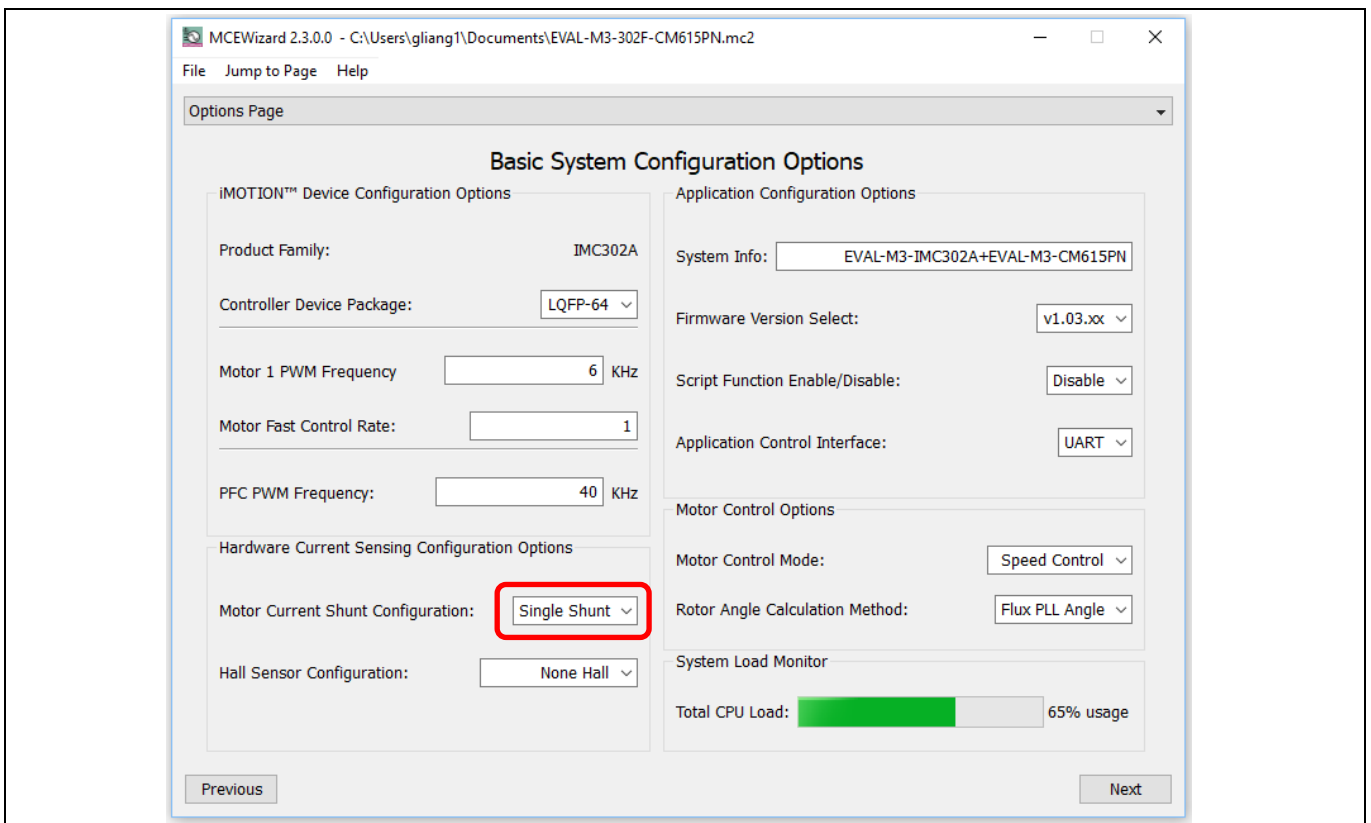

Figure 11 Shunt configuration

6.1.2 Motor external current feedback configuration and calculation

The shunt resistance R_{sh} value can be found in the schematics or User Guide for the power board (for example, the leg shunt resistors are 30 mΩ for EVAL-M3-CM615PN and 100 mΩ for EVAL-M3-TS6-606).

The current input value is a product of the shunt resistance in milliohms and gain of external current sense amplifier as shown in Figure 12.

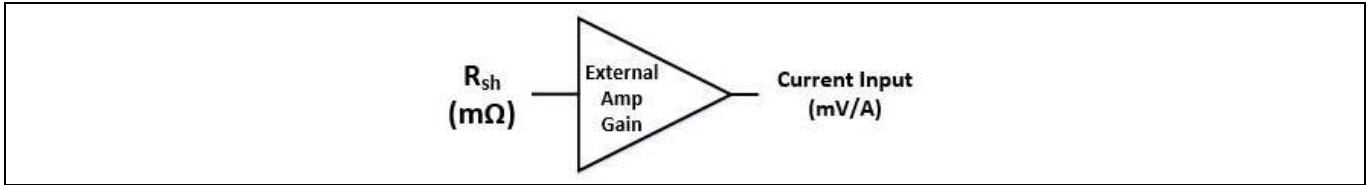

Figure 12 Current shunt feedback and sample timing

Figure 13 depicts IU+ current feedback sensing circuitry on EVAL-M3-302F evaluation board. Please note that the default external amplification gain is less than 1 for current sense in this evaluation board.

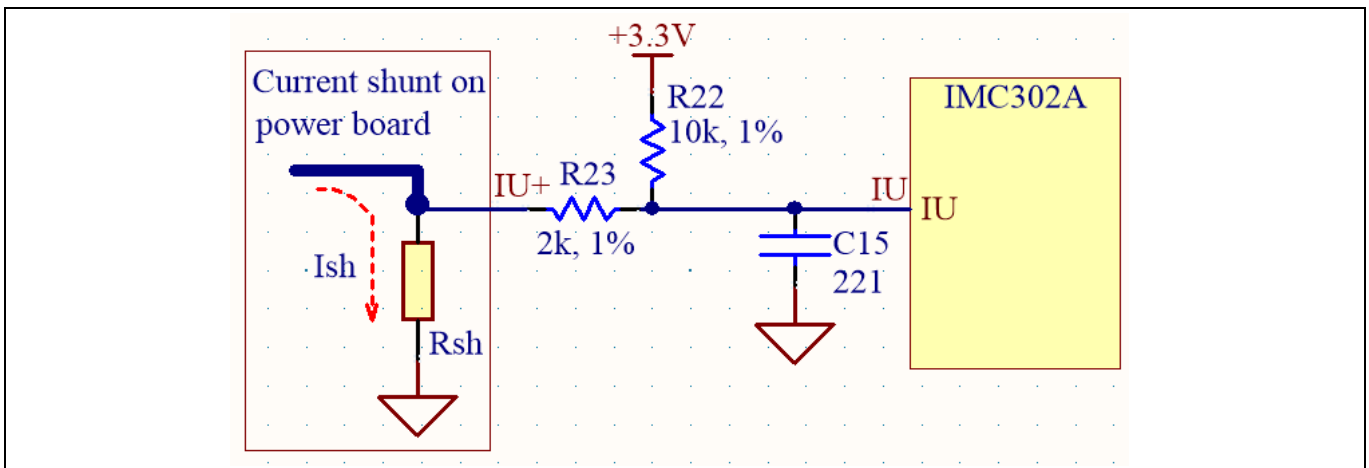

Figure 13 The current feedback section on the EVAL-M3-302F evaluation board

Based on the principle of Kirchhoff's voltage law,

$$V_2 \approx V_1 \approx (V_{DD} - I_{sh} * R_{sh}) * \frac{R_{23}}{R_{22} + R_{23}} + I_{sh} * R_{sh} = \frac{R_{23}}{R_{22} + R_{23}} V_{DD} + \frac{R_{22}}{R_{22} + R_{23}} R_{sh} * I_{sh}$$

$$\text{Current input} = \frac{R_{22}}{R_{22} + R_{23}} R_{sh} = \frac{5}{6} R_{sh}$$

Based on this calculation, and the R_{sh} in EVAL-M3-CM615PN is 30 mΩ, the current input for the MADK combination of EVAL-M3-302F and EVAL-M3-CM615PN is 25 mV/A. Please use same procedure to calculate the current input for other combinations of MADK boards and enter it into MCEWizard.

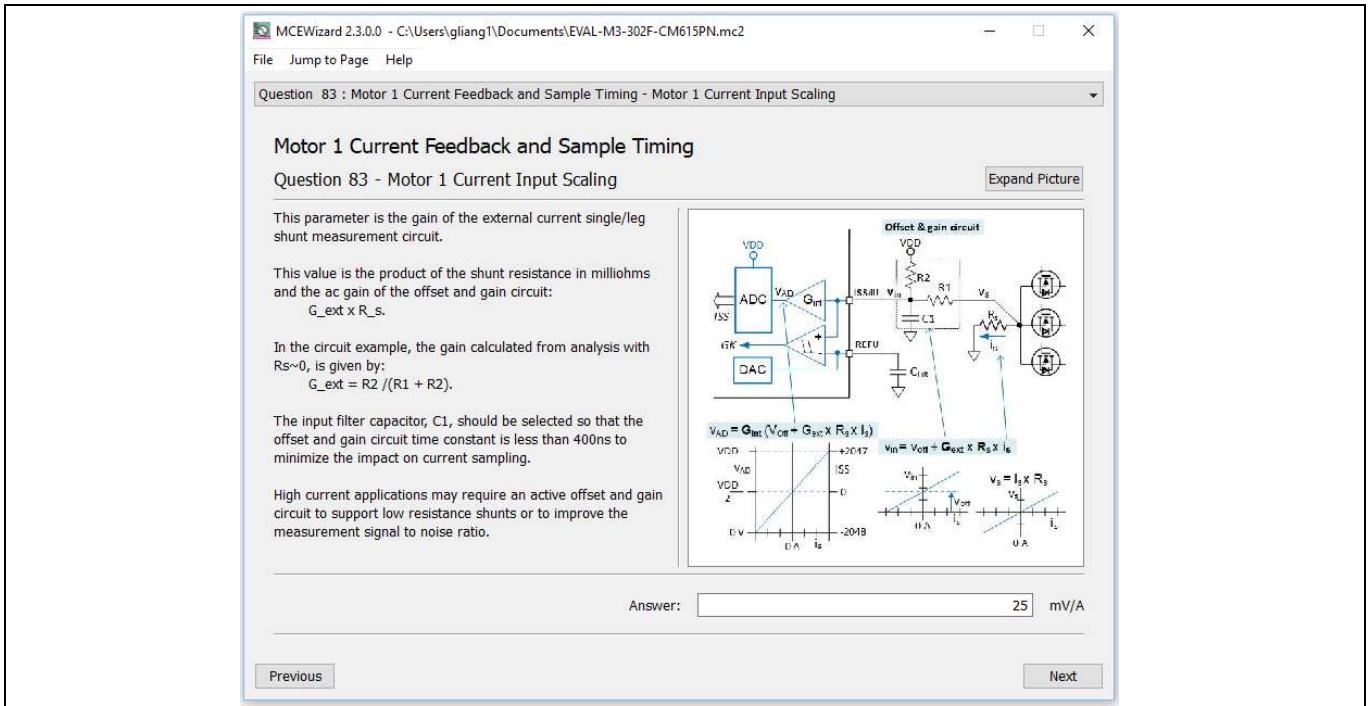

Figure 14 Current feedback configuration in MCEWizard for EVAL-M3-302F and EVAL-M3-CM615PN

6.1.3 Internal amplifier gain configuration

For the current feedback, the iMOTION™ controller on this board has the internal amplifier which has four programmable gain settings: 1x, 3x, 6x and 12x.

The internal current-feedback amplifier gain can be configured in MCEWizard as shown in Figure 15.

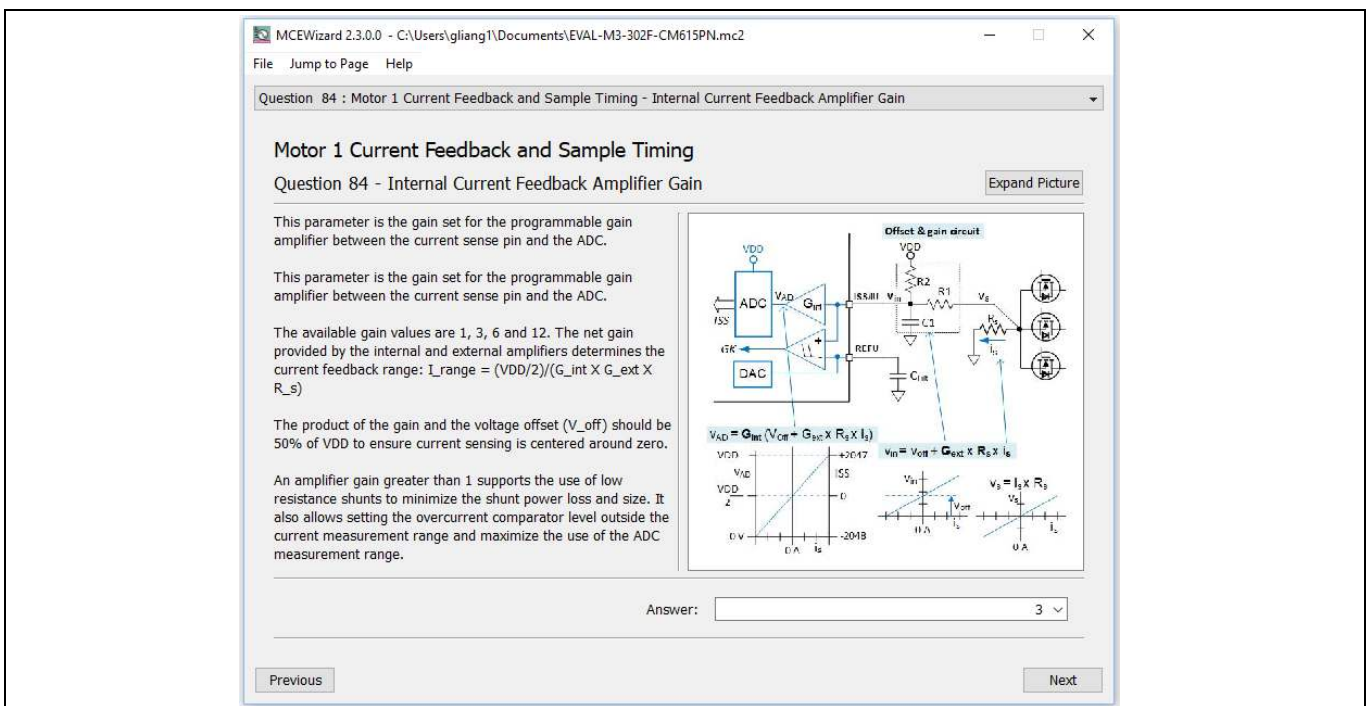

Figure 15 Internal current-feedback amplifier-gain configuration

6.2 PFC hardware configuration

6.2.1 PFC topology selection

The EVAL-M3-302F control board applies to both PFC algorithms, boost mode and totem pole. The user needs to ensure that the topology configuration matches the power board hardware configuration. The topology configuration can be changed in MCEWizard as shown in Figure 16.

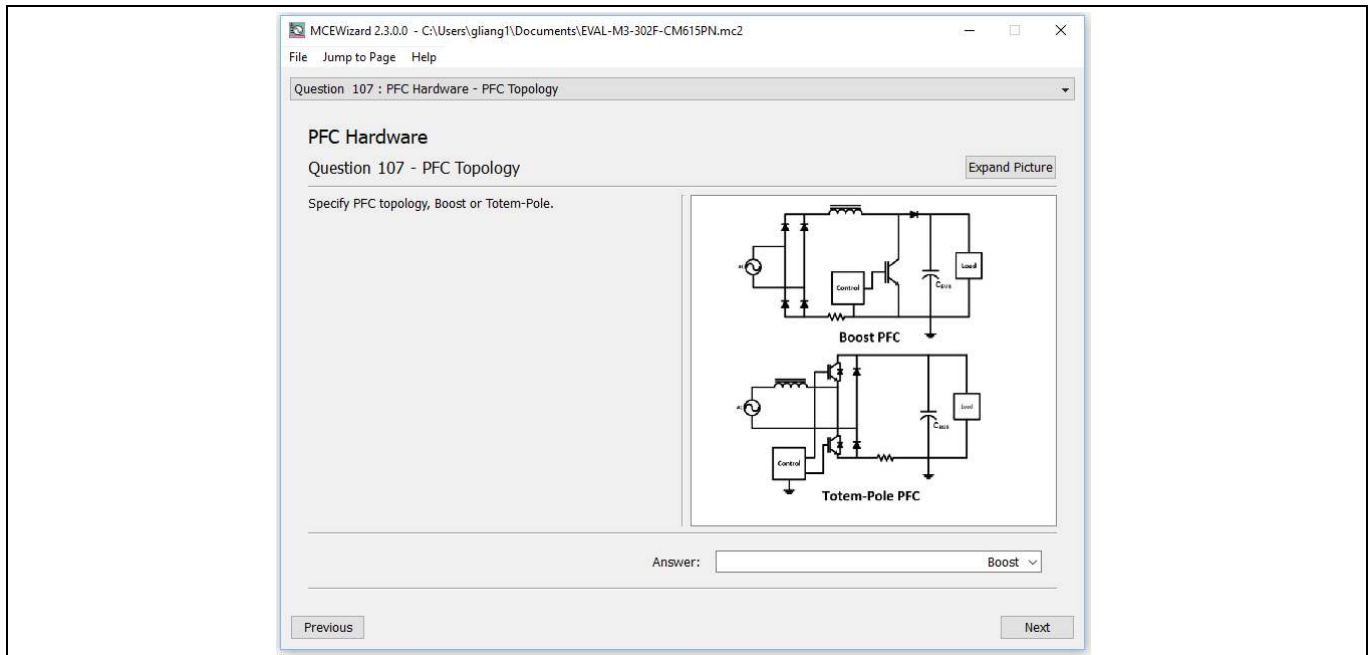

Figure 16 The PFC topology selection in MCEWizard for EVAL-M3-302F and EVAL-M3-CM615PN

6.2.2 PFC external current feedback configuration and calculation

Please refer to the schematic diagram of the power board for the shunt resistance value (for example, the shunt resistors are 30 mΩ for EVAL-M3-CM615PN and 100 mΩ for EVAL-M3-TS6-606).

The current input value is a product of the shunt resistance in milliohms and gain of external current sense amplifier as shown in Figure 17.

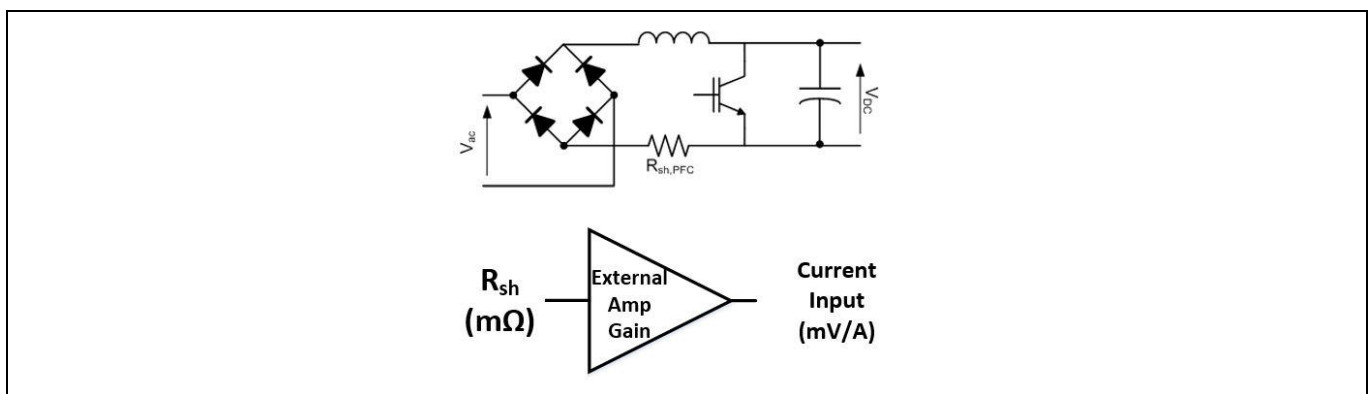

Figure 17 PFC current shunt feedback and sample timing

6.2.3 PFC current feedback configuration

Figure 18 depicts IPFC- current feedback sensing circuitry on EVAL-M3-302F evaluation board. Please note that the default external amplification gain is less than 1 for current sense in this evaluation board.

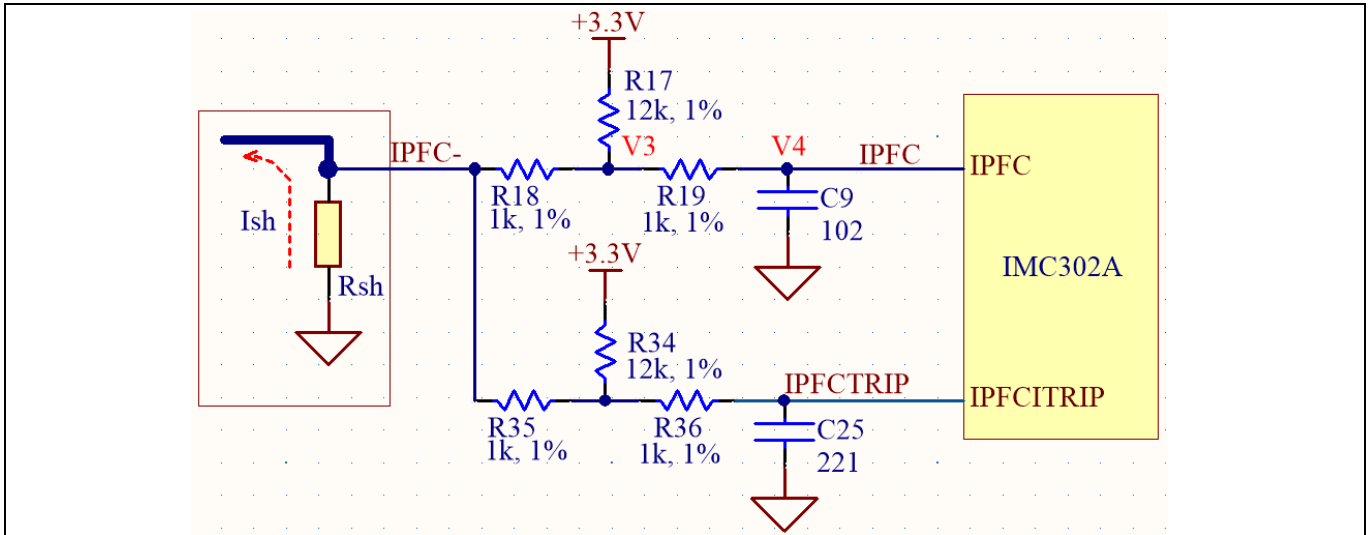

Figure 18 The PFC current feedback circuit for EVAL-M3-302F evaluation board

Based on the principle of Kirchhoff's voltage law,

$$V_4 \approx V_3 \approx (V_{DD} + I_{sh} * R_{sh}) * \frac{R_{18}}{R_{17} + R_{18}} - I_{sh} * R_{sh} = \frac{R_{18}}{R_{17} + R_{18}} V_{DD} - \frac{R_{17}}{R_{17} + R_{18}} R_{sh} * I_{sh}$$

$$\text{Current input} = \frac{R_{17}}{R_{17} + R_{18}} R_{sh} = \frac{12}{13} R_{sh}$$

Based on this calculation, and the R_{sh} in EVAL-M3-CM615PN is 30 mΩ, the current input for the MADK combination of EVAL-M3-302F and EVAL-M3-CM615PN is 27.69 mV/A. Please use the same procedure to calculate the current input for other combinations of MADK boards, and enter it into MCEWizard.

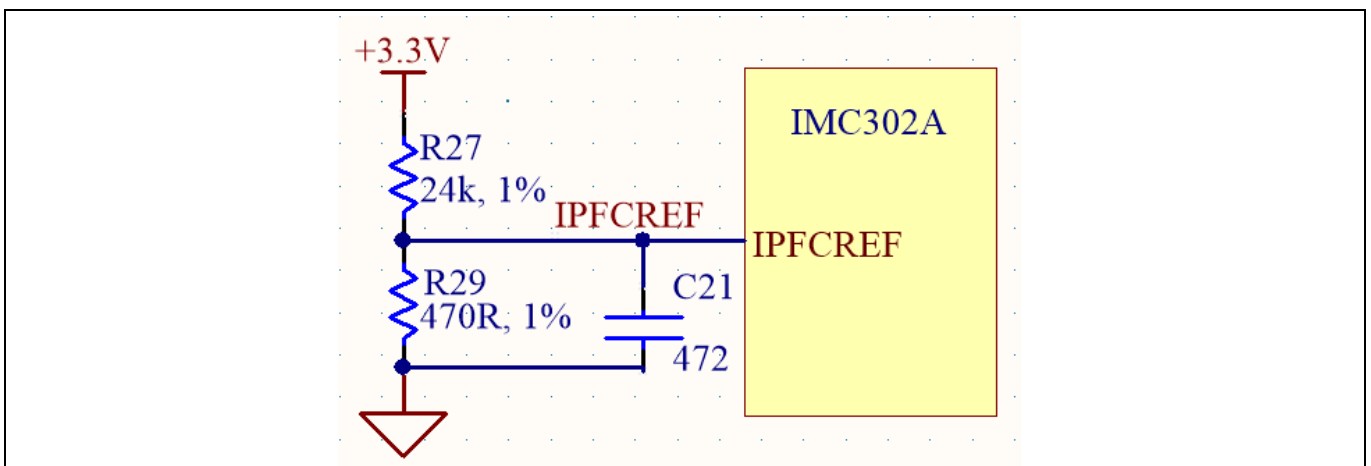

Figure 19 The PFCTRIPREF circuit on the EVAL-M3-302F evaluation board

The PFC's overcurrent protection circuit is shown in Figure 18 and Figure 19.

The calculation formula for the threshold is as follows,

$$I_{PFCTRIP} = V_{DD} \cdot \left(\frac{R9}{R8 + R9} - \frac{R25}{R25 + R6} \right) \cdot \frac{R25 + R6}{R25} \cdot \frac{1}{Rsh}$$

6.2.4 AC voltage-sensing configuration

Figure 20 shows the schematic of EVAL-M3-302F evaluation board with VAC sense.

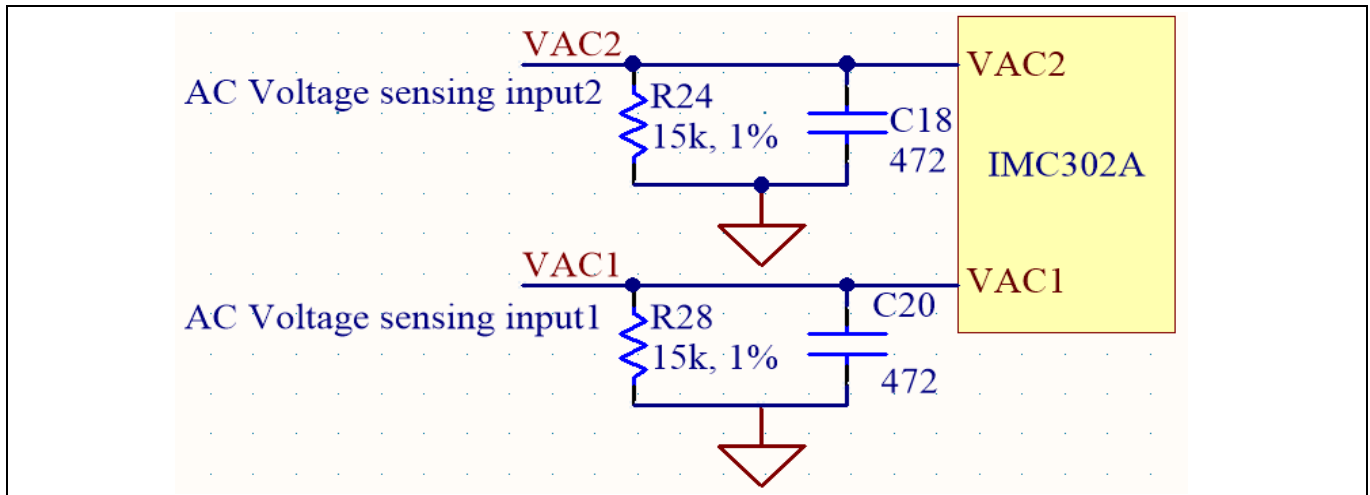

Figure 20 The AC voltage-sensing schematic

There are two AC voltage sensing inputs in differential mode. The high-side resistor for the AC voltage-sensing resistor divider on the power board EVAL-M3-CM615PN is 2000 kΩ, and should be configured in MCEWizard as shown in **Error! Reference source not found.**

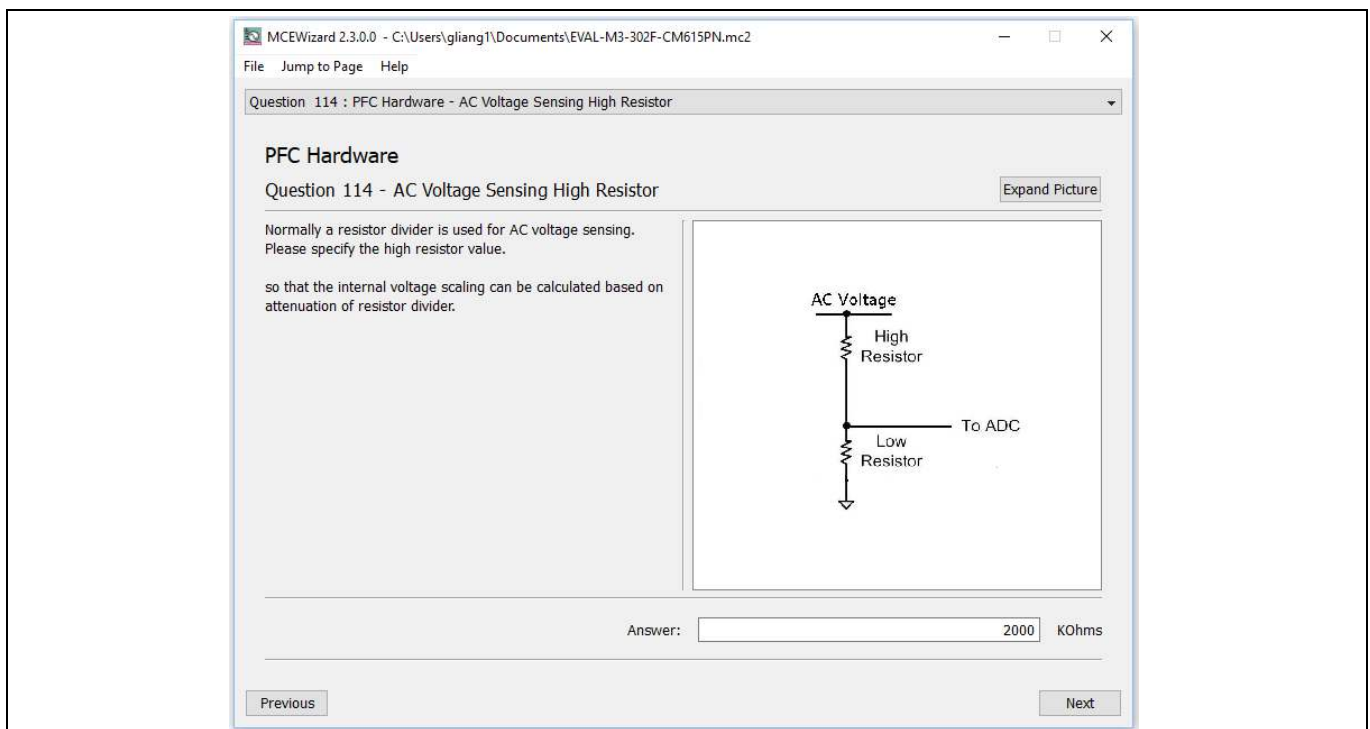

Figure 21 AC voltage-sensing configuration in MCEWizard 1

The low-side resistor R11 or R16 for the AC voltage-sensing resistor divider on the controller board EVAL-M3-302F is 15 kΩ, and should be configured in MCEWizard as shown in Figure 22. For the high-side resistor value, please refer to the User Guide of the corresponding power board.

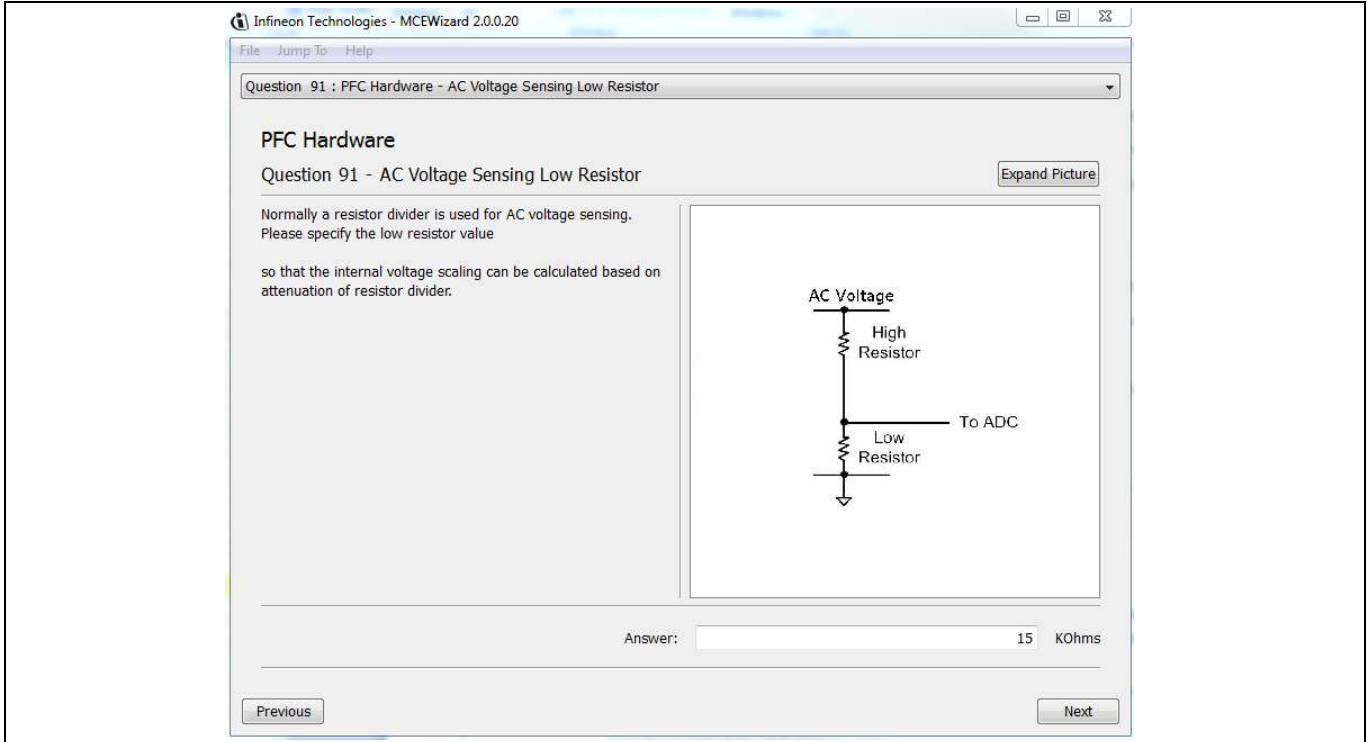

Figure 22 AC voltage sensing configuration in MCEWizard 2

6.3 EVAL-M3-302F analog inputs and their MCEWizard setup

Besides current-sensing inputs, IMC302A-F064 provides a number of analog inputs for different system functions. Figure 23 depicts the analog inputs of the IMC302A-F064 except for the current-sensing inputs.

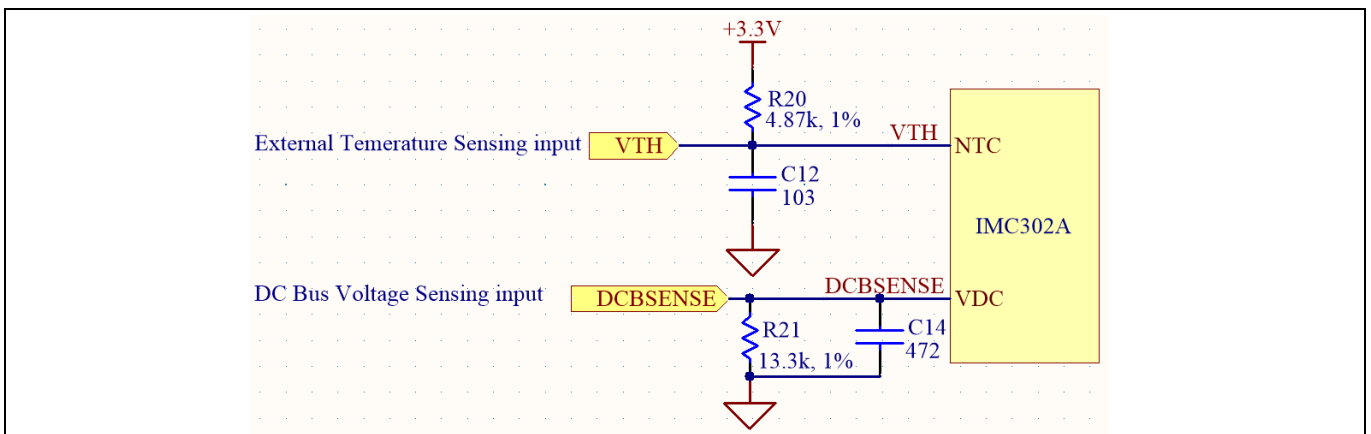

Figure 23 Analog inputs on the EVAL-M3-302F evaluation board

6.3.1 DC bus-sensing configuration

The low-side resistor R4 for the DC bus-sensing resistor divider on the controller board EVAL-M3-302F is 13.3 kΩ, and should be configured in MCEWizard as shown in Figure 24. For the high-side resistor value, please refer to the User Guide of the corresponding power board.

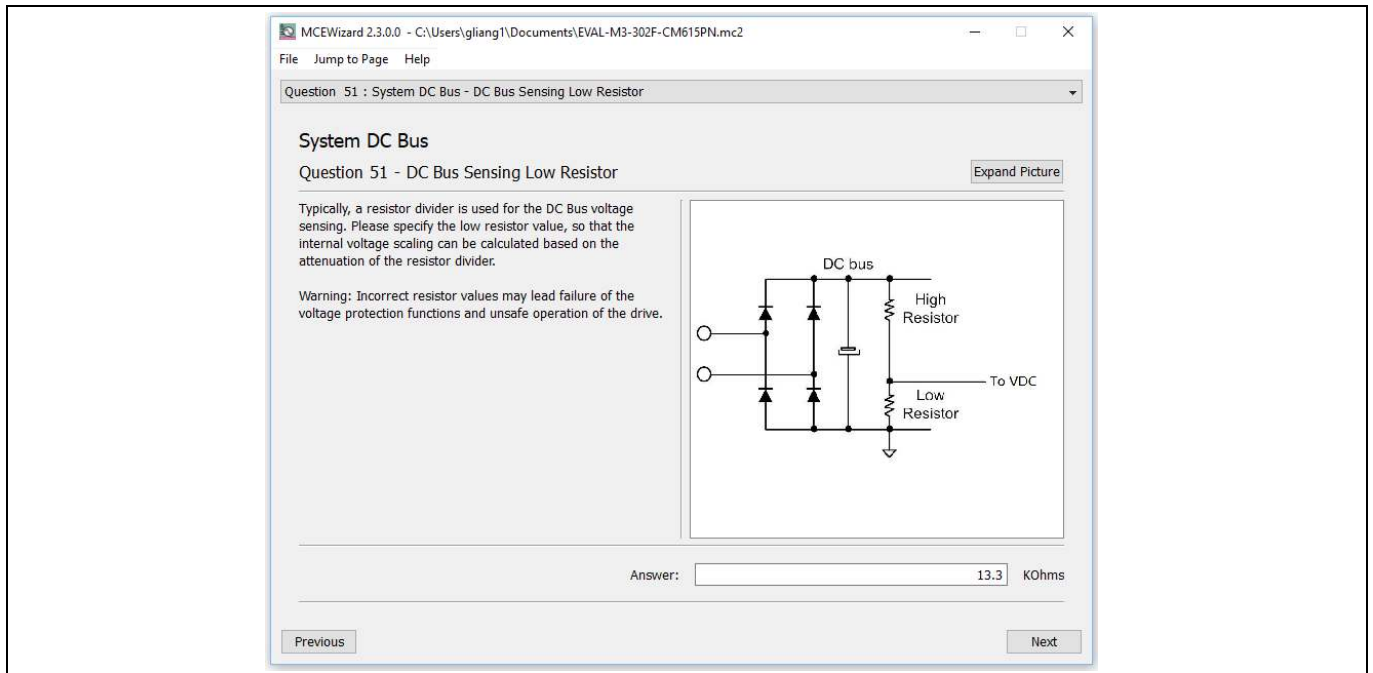

Figure 24 DC bus-sensing configuration in MCEWizard

6.3.2 NTC shutdown value calculation and configuration

External NTC temperature shutdown values can be calculated as shown below and configured in MCEWizard as shown in Figure 25. For the pull-up resistor on the evaluation power board and the NTC value, please refer to the power board’s User Guide. The value of the pull-up resistor on EVAL-M3-302F is 4.87 kΩ (see Figure 23).

$$R_{total\ pull-up} = \frac{R_{pull-up\ on\ Control\ board} * R_{pull-up\ on\ Power\ board}}{R_{pull-up\ on\ Control\ board} + R_{pull-up\ on\ Power\ board}}$$

$$V_{shut\ down} = \frac{R_{NTC@setting\ temperature}}{R_{NTC@setting\ temperature} + R_{total\ pull-up}} V_{DD}$$

For example, for EVAL-M3-CM615PN, the pull-up resistor on the power board is 9.1 kΩ. So the total pull-up resistance calculates to be 3.172 kΩ.

The typical value of R_{NTC} at 100°C is 5.388 kΩ for the IPM IFCM15P60GD that is used in EVAL-M3-CM615PN. If the setting temperature is 100°C, the shutdown value should be 2.08 V.

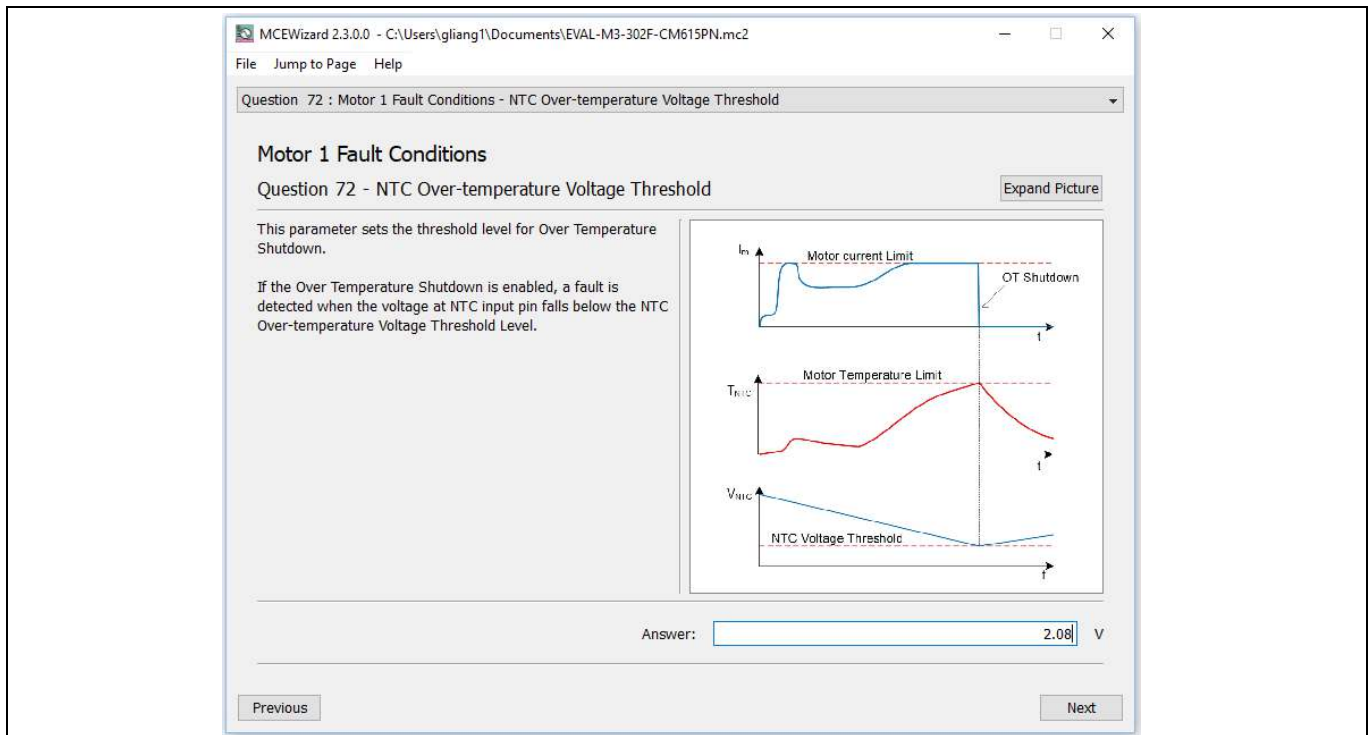

Figure 25 External temperature-sensing input configuration in MCEWizard

6.4 Schematics overview

Figure 26 shows the schematic of EVAL-M3-302F evaluation board with IMC302A-F064 controller.

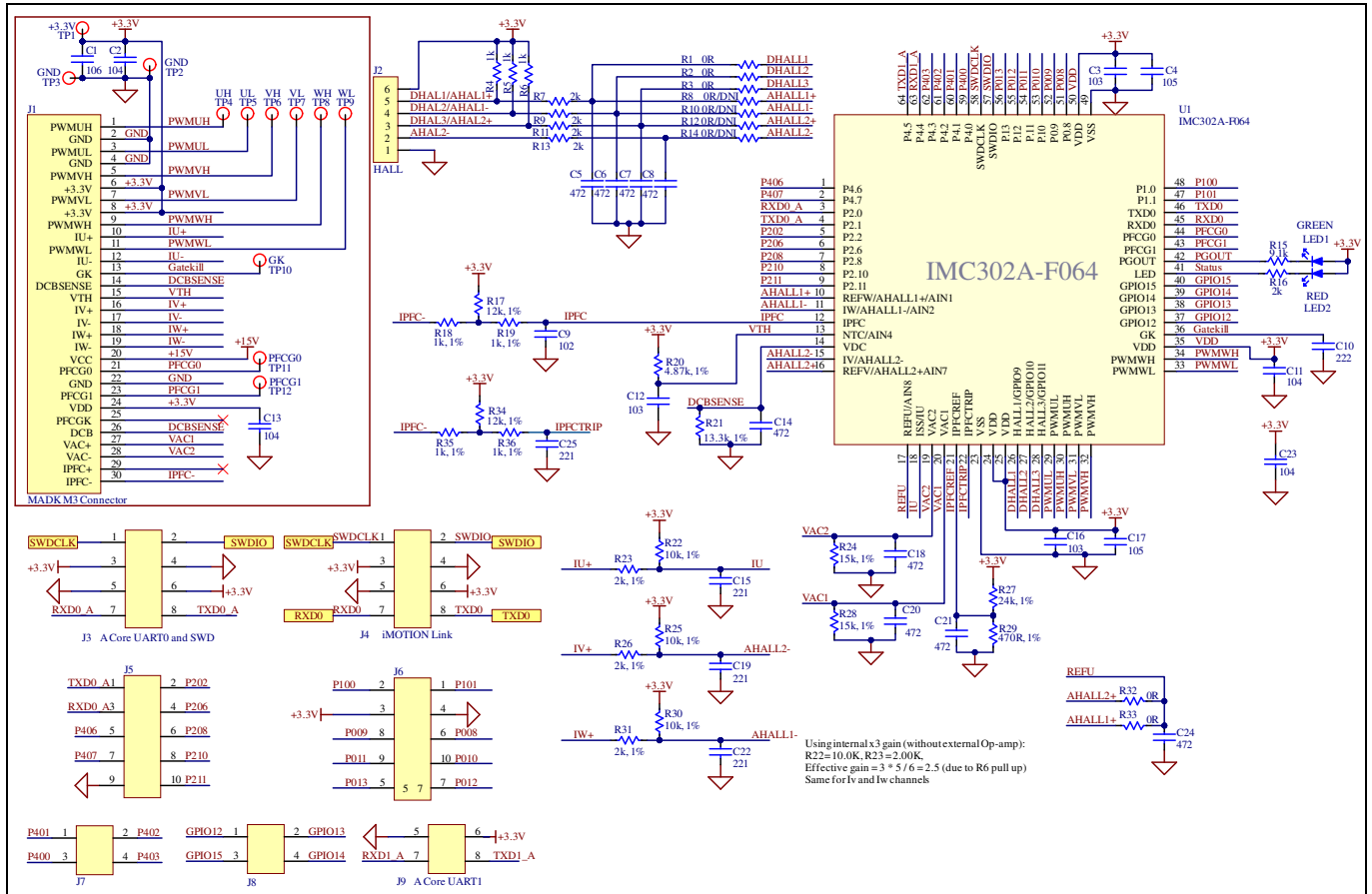

Figure 26 The schematics of the EVAL-M3-302F evaluation board

6.5 PCB layout overview

The layout of this board can be used for different voltages or power classes of the power board. The PCB has two electrical layers with 35 μm copper by default, and its size is 65 mm × 45 mm. The PCB board thickness is 1.6 mm. Check Infineon’s website or get in contact with Infineon’s technical support team to obtain more detailed information and the latest Gerber files.

Figure 27 illustrates the top assembly print and top paste layers of the evaluation board.

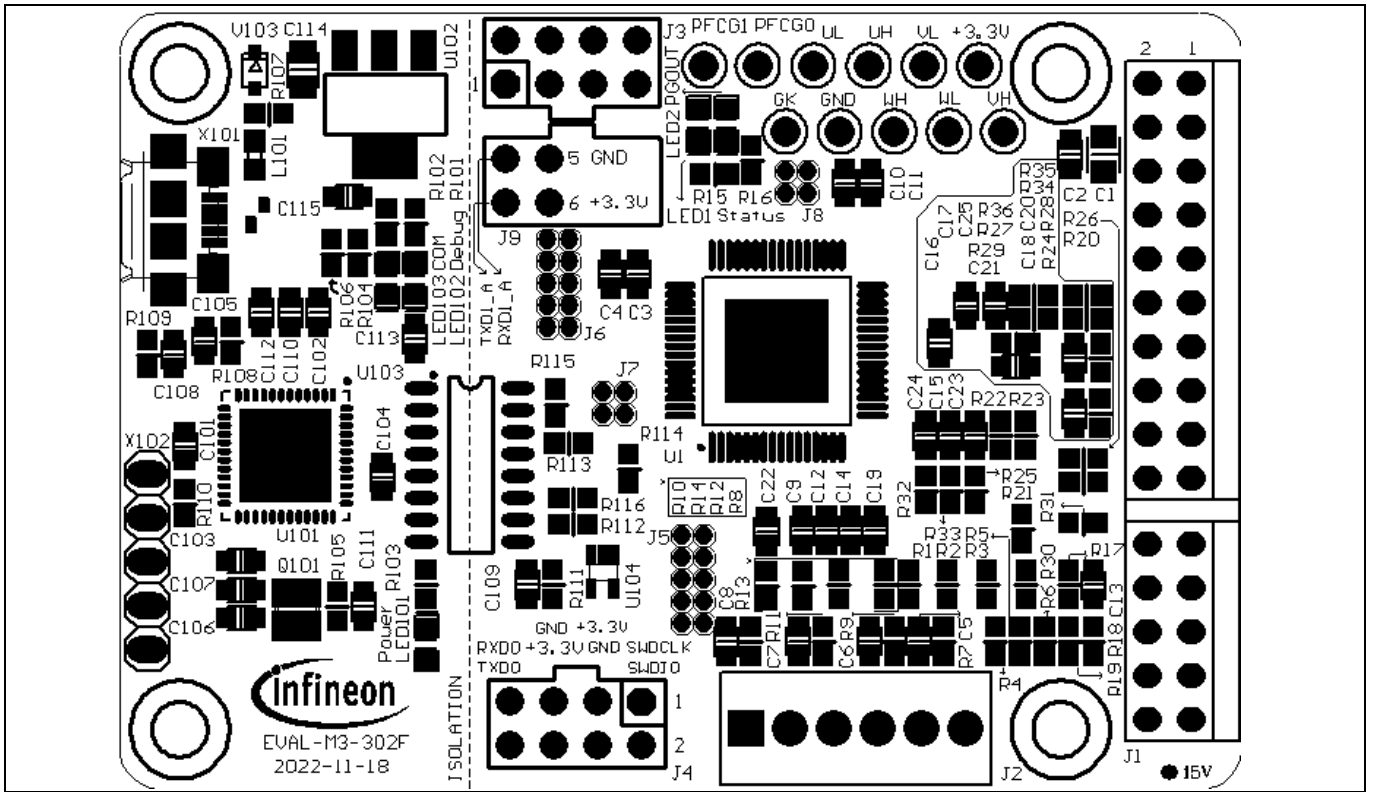

Figure 27 Top overlay print of the EVAL-M3-302F evaluation board

Figure 28 depicts the bottom assembly print of the evaluation board.

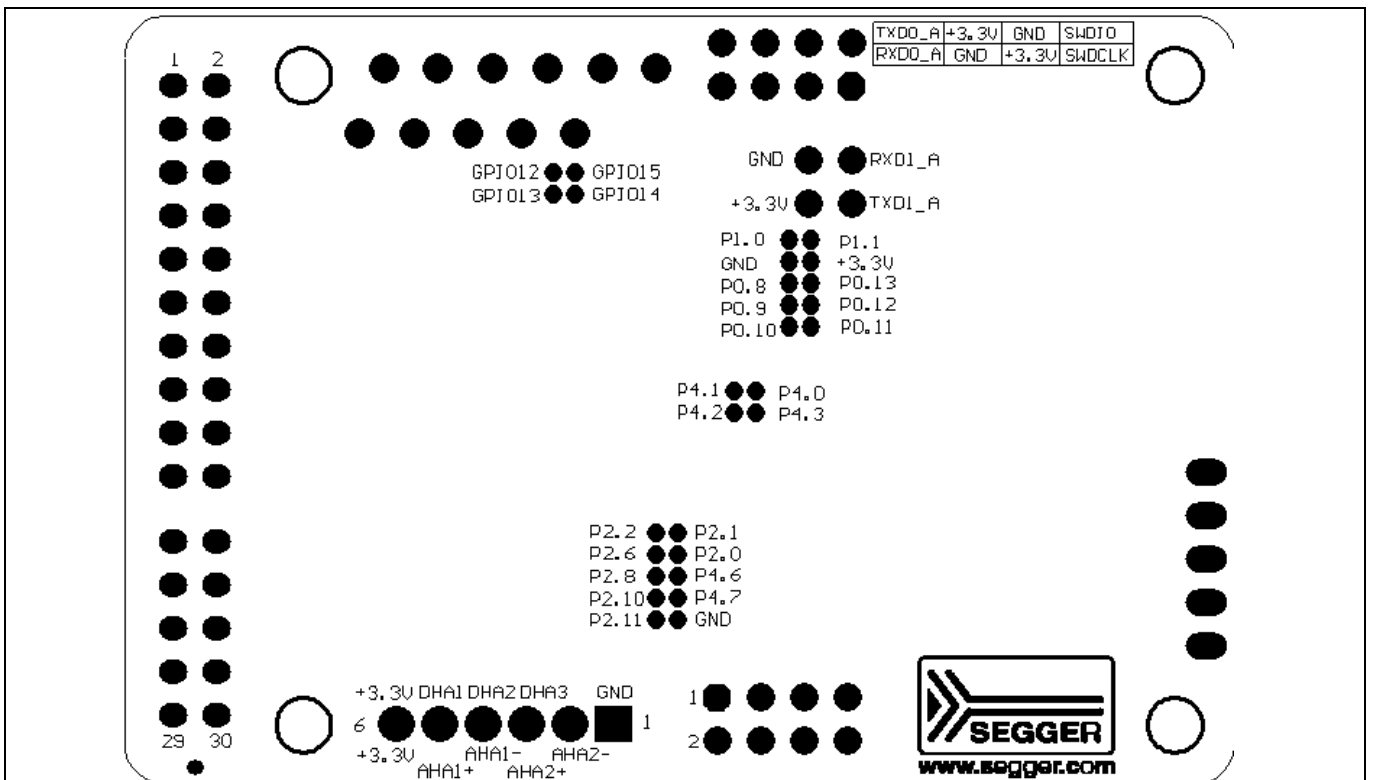

Figure 28 Bottom overlay print of the EVAL-M3-302F evaluation board

The top layer routing of the PCB is provided in the following Figure 29.

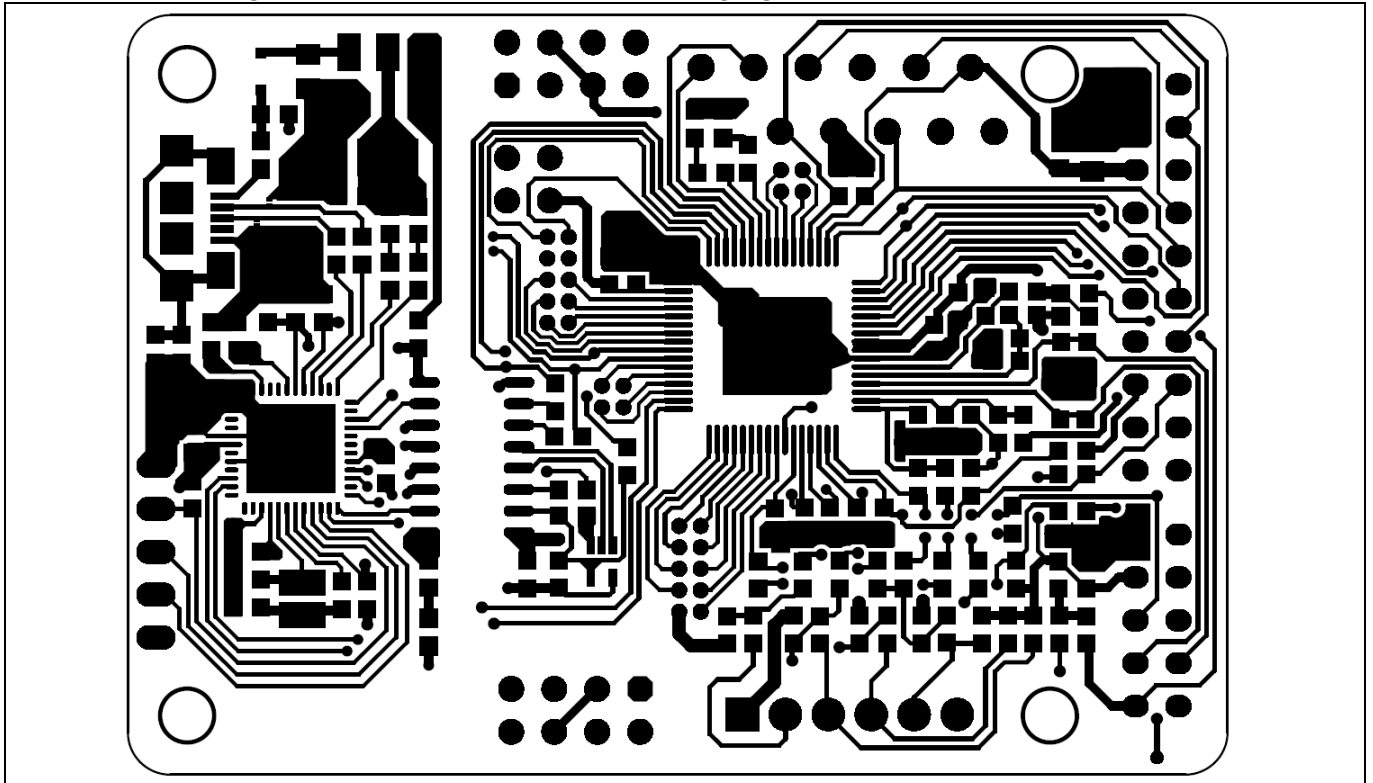

Figure 29 Top layer routing of the EVAL-M3-302F

Figure 30 illustrates the bottom layer routing of the PCB.

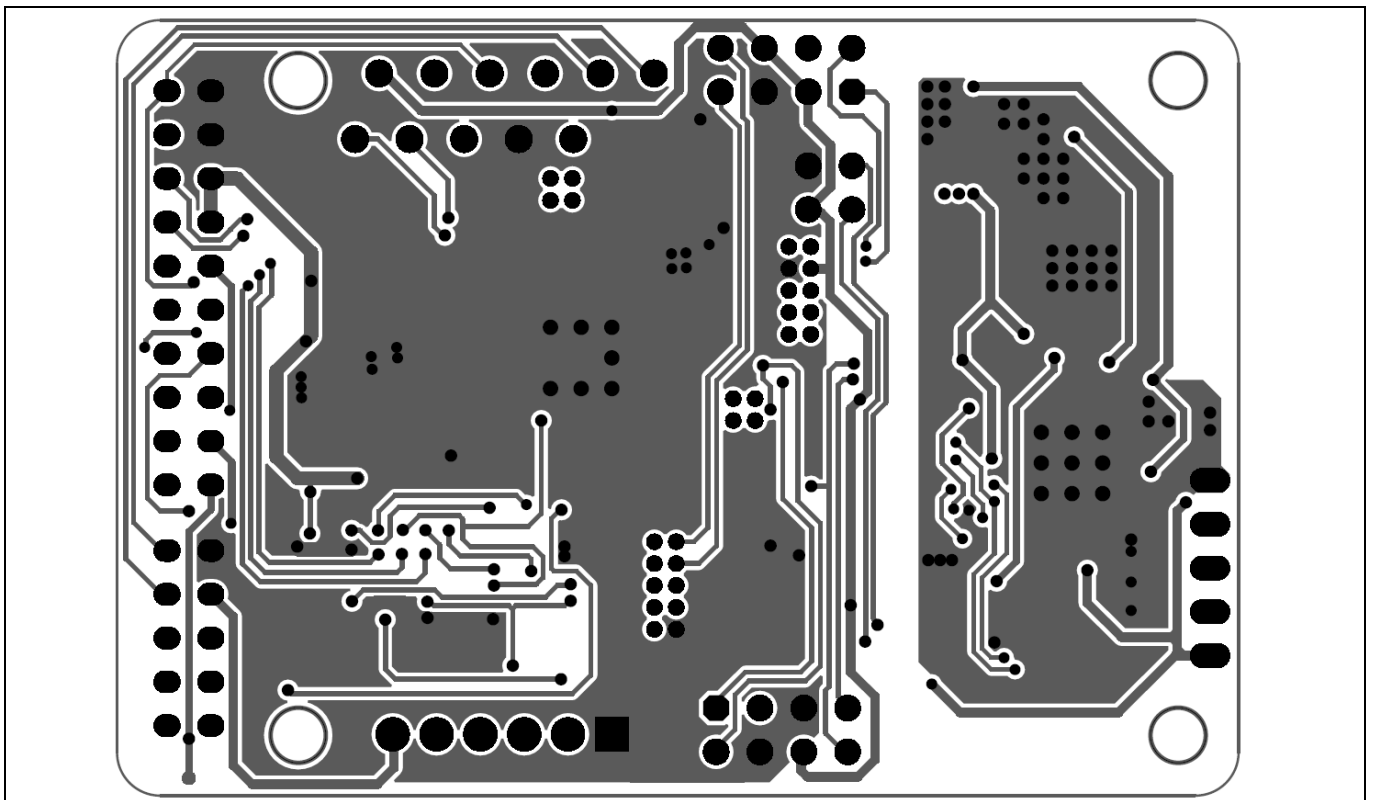

Figure 30 Bottom layer routing of the EVAL-M3-302F

Bill of materials

7 Bill of materials

Table 14 provides the complete bill of materials for the EVAL-M3-302F board.

Table 14 Bill of materials

No.	Qty.	Part description	Designator	Part Number	Manufacturer
1	1	CAP SMD 10uF 16V 0805	C1	885012206014	Würth Electronics Inc.
2	11	CAP SMD 0.1uF 16V 0603	C2, C11, C13, C23, C101, C102, C103, C104, C108, C110, C111	885012206004	Würth Electronics Inc.
3	3	CAP SMD 10nF 16V 0603	C3, C12, C16	885012206010	Würth Electronics Inc.
4	2	CAP SMD 1uF 16V 0603	C4, C17	885012206003	Würth Electronics Inc.
5	9	CAP SMD 4.7nF 16V 0603	C5, C6, C7, C8, C14, C18, C20, C21, C24	885012206012	Würth Electronics Inc.
6	4	CAP SMD 220pF 16V 0603	C9, C15, C19, C22	885012206020	Würth Electronics Inc.
7	1	CAP SMD 2.2nF 16V 0603	C10	885012206012	Würth Electronics Inc.
8	2	CAP SMD 10uF 6.3V 0603	C105, C115	885012206014	Würth Electronics Inc.
9	2	CAP SMD 15pF 16V 0603	C106, C107	885012206020	Würth Electronics Inc.
10	2	CAP SMD 1uF 16V 0603	C109, C113	885012206003	Würth Electronics Inc.
11	1	CAP SMD 4.7uF 16V 0603	C112	885012206012	Würth Electronics Inc.
12	1	CAP SMD 10uF 10V 0805	C114	885012206014	Würth Electronics Inc.
13	9	RES SMD 1/10W 0ohm 0603	R1, R2, R3, R32, R33, R113, R114, R115, R116	RC0603JR-07	
14	3	RES SMD 1/10W 1Kohm 0603	R4, R5, R6	RC0603JR-071KL	
15	6	RES SMD 1/10W 2Kohm 0603	R7, R9, R11, R13, R16, R103	RC0603JR-072KL	
16	4	RES SMD 1/10W 0ohm/DNI 0603	R8, R10, R12, R14	RC0603JR-07	
17	2	RES SMD 1/10W 9.1Kohm 0603	R15, R101	RC0603JR-079K1L	
18	4	RES SMD 1/10W 10Kohm 0603 1%	R17, R22, R25, R30	RC0603FR-0710KL	
19	4	RES SMD 1/10W 2Kohm 0603 1%	R18, R23, R26, R31	RC0603FR-072KL	
20	1	RES SMD 1/10W 1Kohm 0603 1%	R19	RC0603FR-071KL	
21	1	RES SMD 1/10W 4.87Kohm 0603 1%	R20	RC0603FR-074K87L	

Bill of materials

No.	Qty.	Part description	Designator	Part Number	Manufacturer
22	1	RES SMD 1/10W 13.3Kohm 0603 1%	R21	RC0603FR-0713K3L	
23	2	RES SMD 1/10W 15Kohm 0603 1%	R24, R28	RC0603FR-0715KL	
24	1	RES SMD 1/10W 24Kohm 0603 1%	R27	RC0603FR-0724KL	
25	1	RES SMD 1/10W 470ohm 0603 1%	R29	RC0603FR-07470RL	
26	1	RES SMD 1/10W 3Kohm 0603	R102	RC0603JR-073KL	
27	2	RES SMD 1/10W 33ohm 0603	R104, R106	RC0603JR-0733RL	
28	1	RES SMD 1/10W 510ohm 0603	R105	RC0603JR-07510RL	
29	2	RES SMD 1/10W 4.7Kohm 0603	R107, R111	RC0603JR-074K7L	
30	2	RES SMD 1/10W 10Kohm 0603	R108, R110	RC0603JR-0710KL	
31	1	RES SMD 1/10W 1Mohm 0603	R109	RC0603JR-071ML	
32	1	RES SMD 1/10W DNI 0603	R112	RC0603JR-07	
33	1	CONN HEADER DUAL 30POS RA 2.54	J1	61303021021	
34	1	CONN HEADER VERT SING 6POS 2.54	J2	61300611121	
35	2	CONN HEADER VERT DUAL 8POS 2.54	J3,J4	61300821121	
36	2	CONN HEADER VERT DUAL 10POS 1.27	J5,J6	61301021111	
37	2	CONN HEADER VERT DUAL 4POS 1.27	J7, J8	61300421111	
38	1	CONN HEADER VERT DUAL 4POS 2.54	J9	61300421121	
39	1	FERRITE BEAD 60ohm 0603 1LN	L101	BLM18PG600	
40	2	LED GREEN CLEAR 0603 SMD	LED1, LED102	150060GS75000	Würth Electronics Inc.
41	2	LED RED CLEAR 0603 SMD	LED2, LED101	150060RS75000	Würth Electronics Inc.
42	1	LED BLUE CLEAR 0603 SMD	LED103	150060BS75000	Würth Electronics Inc.
43	1	OSC 12.0000MHz SMD	Q101	12MHz/S/3.2X2.5	
44	12	TEST POINT PC MINI .040"D BLACK	TP1,TP2,TP 3,TP4,TP5,T P6,TP7,TP8, TP9,TP10,T P11,TP12	5001	
45	1	IC MCU 32BIT 128KB FLASH LQFP64	U1	IMC302A-F064	Infineon Technology
46	1	IC MCU 32BIT 256KB FLASH 48VQFN	U101	XMC4200_QFN48	Infineon Technology
47	1	IC REG LINEAR 3.3V 1A SOT223-4	U102	IFX1117-ME V33	Infineon Technology
48	1	DGTL ISO 3.75KV GEN PURP SO- 16-NB	U103	Si8662EC-B-IS1	
49	1	IC BUFF TSSOP5	U104	74LVC1G126GW	

Bill of materials

No.	Qty.	Part description	Designator	Part Number	Manufacturer
50	2	TVS DIODE 17VC WLL-2-1	V101, V102	ESD237-B1-W0201	Infineon Technology
51	1	DIODE SCHOTTKY 30V 1A SOD323-2	V103	BAS3010A-03W	Infineon Technology
52	1	CONN RCPT MICRO USB AB SMD R/A	X101	ZX62-AB-5PA	
53	1	CONN HEADER VERT SING 5POS 2.54	X102	61300521121	

8 Reference

- [1] Infineon-IMC300_series-DataSheet-v01_00-EN.pdf
- [2] iMOTION™ MCE Software Reference Manual
- [3] MCEWizard User Guide
- [4] MCEDesigner User Guide

Note: All listed reference materials are available for download on Infineon's website www.infineon.com/imotion. All User Guides of the iMOTION™ MADK power boards are available at www.infineon.com/MADK

Notice:

Infineon's product registration is now online. You can register your board online, and download additional information.

There are three easy steps to register:

1. Go to www.infineon.com/ login to myinfineon
2. Click on "Product Registration"
3. Choose your board, and enter board series number, then download the related information package

Revision history

Document version	Date of release	Description of changes
1.0	2020-05-22	First release
1.1	2022-07-28	Typo correction in table5, table8, table11
1.2	2022-11-18	Fixed the naming of pin5 and pin7 for table 8 and figure 26,27,28

Trademarks

All referenced product or service names and trademarks are the property of their respective owners.

Edition 2022-11-18

Published by

Infineon Technologies AG

81726 Munich, Germany

© 2023 Infineon Technologies AG.

All Rights Reserved.

Do you have a question about this document?

Email: erratum@infineon.com

Document reference

UG-2020-12

For further information on the product, technology, delivery terms and conditions and prices please contact your nearest Infineon Technologies office (www.infineon.com).

WARNINGS

Due to technical requirements products may contain dangerous substances. For information on the types in question please contact your nearest Infineon Technologies office.

Except as otherwise explicitly approved by Infineon Technologies in a written document signed by authorized representatives of Infineon Technologies, Infineon Technologies' products may not be used in any applications where a failure of the product or any consequences of the use thereof can reasonably be expected to result in personal injury.