

TPS23882EVM: PoE, PSE, TPS23882 Evaluation Module

This user's guide describes the evaluation modules (EVM) for the TPS23882 (TPS23882EVM-008 and BOOST-PSEMTHR8-097). The EVM contains evaluation and reference circuitry for the TPS23882. The TPS23882 is a Power-over-Ethernet (PoE) device for power sourcing equipment (PSE).

Contents

1	Description	2
2	Quick Start	2
3	General Use Features	7
4	TPS23882 GUI Setup	9
5	EVM Schematic, Layout Guidelines, PCB Assembly and Layer Plots	17
6	Bill of Materials	26

List of Figures

1	Basic Setup Using Autonomous Mode.....	4
2	Basic Setup Using USB2ANY	5
3	Advanced Setup Using LaunchPad™	6
4	TPS23882 GUI Startup Window	10
5	TPS23882 GUI Load Firmware 1	11
6	TPS23882 GUI Load Firmware 2	11
7	Device Configuration and Port Telemetry Page	12
8	Register Map	13
9	Semi-Auto UART Transmission Startup.....	14
10	Semi-Auto UART Transmission Status.....	15
11	Auto Mode System Software Structure.....	16
12	Semi Auto Mode System Software Structure.....	17
13	BOOST-PSEMTHR8-097 (Motherboard) Schematic: Control.....	18
14	BOOST-PSEMTHR8-097 (Motherboard) Schematic: Power Ports.....	19
15	TPS23882EVM-008 (Daughterboard) Schematic.....	20
16	BOOST-PSEMTHR8-097 (Motherboard) Top Side Assembly	21
17	BOOST-PSEMTHR8-097 (Motherboard) Top Side Routing.....	22
18	BOOST-PSEMTHR8-097 (Motherboard) Layer 2 Routing	22
19	BOOST-PSEMTHR8-097 (Motherboard) Layer 3 Routing	23
20	BOOST-PSEMTHR8-097 (Motherboard) Bottom Side Routing.....	23
21	TPS23882EVM-008 (Daughterboard) Top Side Assembly	24
22	TPS23882EVM-008 (Daughterboard) Top Side Routing	24
23	TPS23882EVM-008 (Daughterboard) Bottom Side Routing	24
24	TPS23882EVM-008 (Daughterboard) Bottom Side Assembly	25

List of Tables

1	TPS23882 Voltage Rail Current Requirements	3
2	AUTO Pin Programming	4
3	EVM Input/Output Connectors	7
4	EVM LEDs	7

<i>Description</i>	www.ti.com
5 EVM Test Points	8
6 EVM Jumpers	8
7 BOOST-PSEMTHR8-097 Bill of Materials	26
8 TPS23882EVM-008 Bill of Material	28

Trademarks

LaunchPad, Code Composer Studio are trademarks of Texas Instruments.
All other trademarks are the property of their respective owners.

1 Description

The TPS23882 features the TPS23882: an 8-channel, IEEE802.3bt compliant PoE PSE controller. The EVM consists of a motherboard (BOOST-PSEMTHR8-097) and a daughterboard (TPS23882EVM-008) containing one TPS23882 device. The TPS23882 EVM provides a multi-port base platform interface for TPS23882EVM-008, [MSP-EXP430FR5969](#) (LaunchPad™), and [USB2ANY](#) (USB Interface Adapter).

1.1 Features

The EVM supports the following features:

- Eight IEEE802.3bt 2-pair ports with 1000BASE-T (gigabit Ethernet data pass-through)
- Single DC power supply input
- Onboard 3.3-V regulator
- Onboard I²C interface to the TPS23882 device from either [USB2ANY](#) or [MSP-EXP430FR5969](#).
- Port ON status LEDs
- Reset button for easy reconfiguration
- User test points

1.2 Applications

The EVM is used in the following applications:

- Enterprise and SoHO switches and routers
- Connected ceiling LED switches
- PoE pass-through power modules
- Network video recorders (NVRs)
- Wireless backhaul and small-cell networking

2 Quick Start

2.1 Input Power

2.1.1 Input Power (Labeled VPWR)

The DC input voltage is provided through J1 on the mother board(screw jack). A DC power supply or wall adapter with sufficient current capacity can power the EVM.

CAUTION

Reverse voltage protection is not provided; ensure that the correct polarity is applied to J1.

This DC input is labeled *VPWR* in the schematics, is used for port VBUS and for the TPS23882 devices. The VPWR connections to the PoE ports are not fused. Each two-pair port is capable of furnishing at least 30 W.

The minimum PSE port voltage is 44 VDC for type 1 and 50 V for type 2 and type 3. During evaluation, choose the appropriate DC power supply for different environments.

2.1.2 Local 3.3 V (Labeled 3.3 V)

Local 3.3 V for local devices (labeled as 3.3 V) is provided by the onboard LM5019 buck converter. The LM5019 provides a basic power-on sequence and provides a well-controlled and consistent startup. In addition to 54 V, the TPS23882 requires 3.3 V for the digital circuitry and this is routed up to TPS23882EVM-008 over the connector interface. The current consumption is 6-mA typical and 12-mA maximum.

2.1.3 External 3.3 V (Labeled 3.3 V_USB)

The BOOST-PSEMTHR8-097 provides galvanic isolation between the PoE power side and host side using digital isolators (ISO7241CD). The host side power is provided either from J2 of the mother board (from [USB2ANY](#)) or J5 of the mother board (from [MSP-EXP430FR5969](#)).

CAUTION

Do not use USB2ANY and LaunchPad simultaneously.

Table 1. TPS23882 Voltage Rail Current Requirements

Voltage Rail	Typical (mA)	Maximum (mA)
3.3 V_USB	2.5	3
3.3 V	6	12
VPWR (Miscellaneous)	35	57
VPWR (8 × 2 Pair Ports)	4800	5455
VPWR Total (8 × 2 Pair Ports)	4835	5512

2.2 PoE Port Interfaces

The TPS23882 device must be configured through the host to become operational. This EVM provides 2 ways to control the TPS23882: TPS238x EVM GUI (with [USB2ANY](#)) and Basic Reference Code (with [MSP-EXP430FR5969](#) LaunchPad).

2.2.1 IEEE802.3bt 2-Pair Ports

Eight 2-pair ports are provided at J19, J20, J8, J7, J32, J33, J21, and J9 of the mother board for 2-pair ports 1, 2, 3, 4, 5, 6, 7, and 8 respectively. The power furnished is according to alternative A with MDI-X polarity.

2.3 I²C Interfaces

Two I²C interfaces to the TPS23882 are provided on the EVM.

2.3.1 USB2ANY

J2 of the mother board provides an interface with the [USB2ANY](#) adapter when using a PC and GUI.

2.3.2 MSP-EXP430FR5969

J3, J4, and J5 of the mother board provide an interface with the [MSP-EXP430FR5969](#) when using a PC to develop custom system software.

2.4 Basic Test Setup Using Autonomous Mode

The TPS23882 supports autonomous mode which means it can operate without any host control. During power up the resistance on the AUTO pin is measured and the device is pre-configured according to the jumper configuration on J5 of the daughter board. All ports are configured with the same power level. Due to the hardware configuration on the mother board, all 2-pair ports are interoperable with PDs. Only 2P-15W and 2P-30W are valid selections on the TPS23882EVM-008 as the other resistors are not populated.

In order to test with autonomous mode, install a jumper on the pins of J5 corresponding to the desired power level and power on the board without the [USB2ANY](#) or [MSP-EXP430FR5969](#) connected. [Figure 1](#) illustrates the basic setup using autonomous mode.

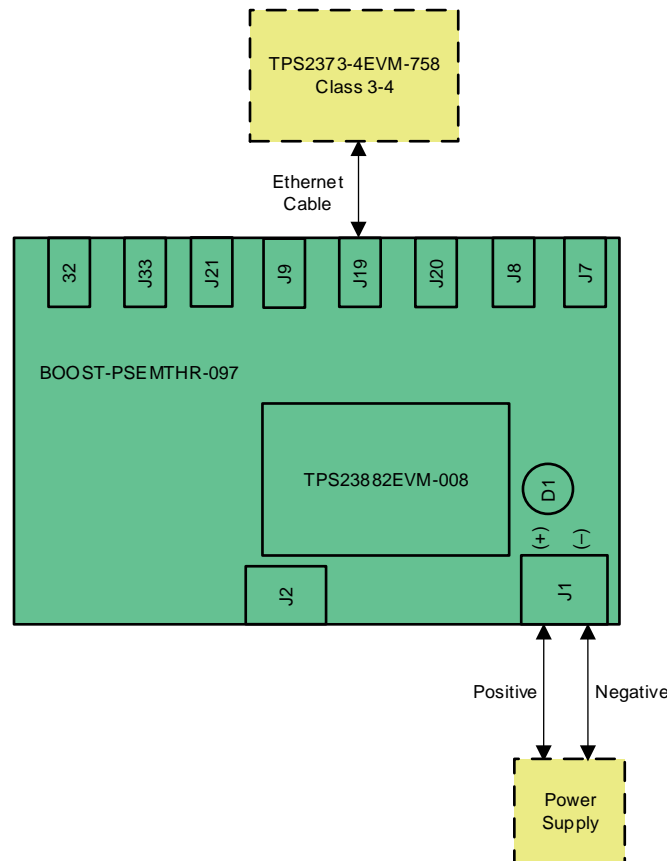

Figure 1. Basic Setup Using Autonomous Mode

If the EVM is powered with a jumper on J5 of the daughterboard, the device will automatically enter autonomous mode at the selected power level. If the selected power level changes, the EVM must be power cycled for the change to take effect.

Table 2. AUTO Pin Programming

AUTO Pin	Autonomous Mode Configuration	Resulting Register Configurations		
		Register 0x12h	Register 0x14h	Register 0x29h
Open/Floating	Disabled	0x00h	0x00h	0x00h
124 k Ω	2-pair 15 W	0xFFh	0xFFh	0x00h
62 k Ω	2-pair 30 W	0xFFh	0xFFh	0x33h

2.5 Basic Test Setup Using USB2ANY for PC Interface (Auto Mode or Semi-Auto Mode Operation with PC Monitoring)

An I²C interface is provided through J2 of the mother board to the TPS23882 device on the TPS23882EVM-008. The USB2ANY adapter (not included) can be used with any TI GUI which uses USB2ANY to read and write over an I²C bus. Figure 2 illustrates the basic setup using USB2ANY.

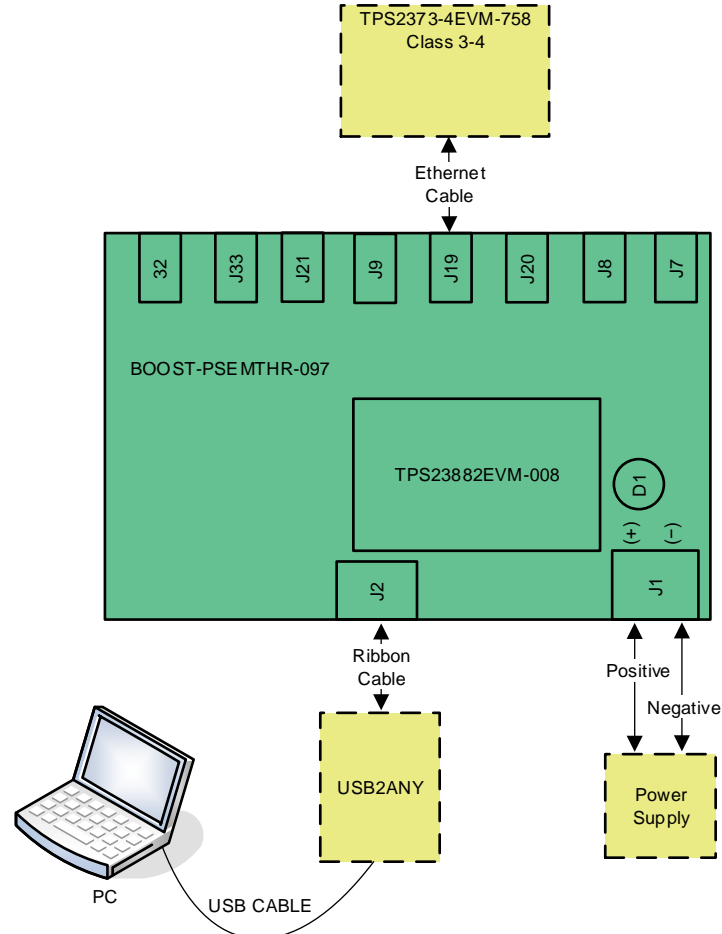

Figure 2. Basic Setup Using USB2ANY

CAUTION

If wanting to run TPS23882 in semi auto mode, remove the jumper installed on J5 of the TPS23882 daughter board before powering on the board.

2.6 Advanced Test Setup Using MSP-EX430FR5969 LaunchPad™

The LaunchPad (not included) running a custom software program can communicate with the TPS23882 devices on the TPS23882EVM-008. [Figure 3](#) shows the advanced setup using LaunchPad.

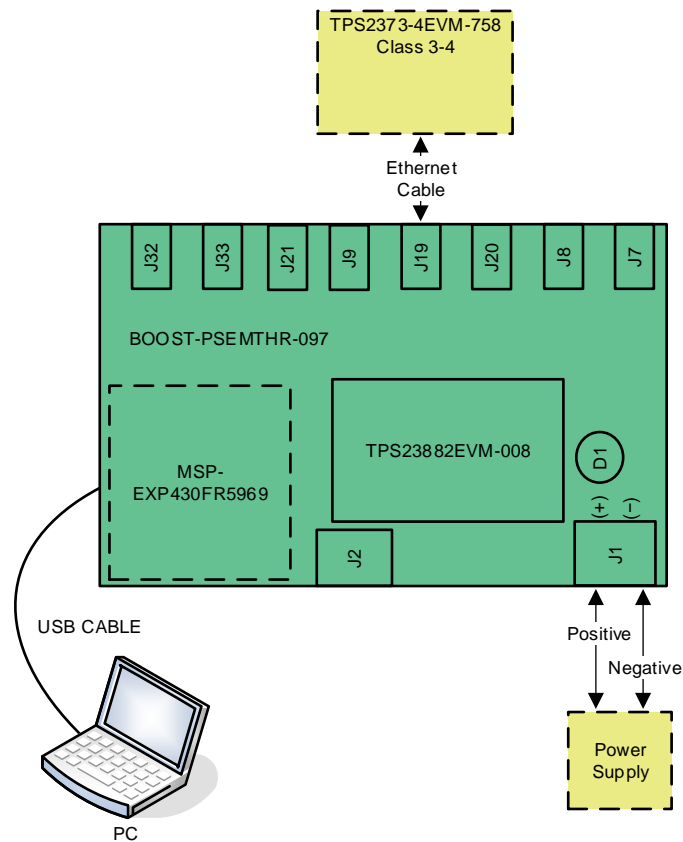

Figure 3. Advanced Setup Using LaunchPad™

CAUTION

If wanting to run TPS23882 in semi auto mode, remove the jumper installed on J5 of the TPS23882 daughter board before powering on the board.

CAUTION

Do not press the RESET button (S1) on the motherboard while communicating over I2C. Pressing this button will set all ports to off mode and the reference code will not be able to recover.

3 General Use Features

3.1 EVM Input/Output Connectors and Switches

Table 3 lists the EVM input and output connectors on the mother board.

Table 3. EVM Input/Output Connectors

Connector or Switch	Label	Description
S1	RESET	Button to send a hardware reset signal to the TPS23882
J1	J1	DC power supply screw jack. (44–57 VDC). Use a 48 VDC (nominal) for type 1 and 54 VDC (nominal) for type 2, 3, and 4 PSE operation.
J2	J2	Ribbon cable connection to USB2ANY adapter
J3	J3	LaunchPad control (mates with LaunchPad J1)
J4	J4	LaunchPad I ² C (mates with LaunchPad J2)
J5	J5	LaunchPad power (onboard, mates with LaunchPad J6)
J6	J6	TPS23882EVM-008 control (mates with TPS23882EVM-008 J3)
J17	J17	TPS23882EVM-008 Channel 5–8 (mates with TPS23882EVM-008 J2)
J18	J18	TPS23882EVM-008 Channel 1–4 (mates with TPS23882EVM-008 J1)
J22	J22	Two-pair port 1 data only
J19	2 Pair Port 1	Two-pair port 1 power and data
J23	J23	Two-pair port 2 data only
J20	2 Pair Port 2	Two-pair port 2 power and data
J11	J11	Two-pair port 3 data only
J8	2 Pair Port 3	Two-pair port 3 power and data
J10	J10	Two-pair port 4 data only
J7	2 Pair Port 4	Two-pair port 4 power and data
J31	J31	Two-pair port 5 data only
J32	2 Pair Port 5	Two-pair port 5 power and data
J30	J30	Two-pair port 6 data only
J33	2 Pair Port 6	Two-pair port 6 power and data
J24	J24	Two-pair port 7 data only
J21	2 Pair Port 7	Two-pair port 7 power and data
J12	J12	Two-pair port 8 data only
J9	2 Pair Port 8	Two-pair port 8 power and data
J29	J29	Chassis ground tie point

3.2 EVM LEDs

Table 4 lists the mother board LEDs and their descriptions.

Table 4. EVM LEDs

LED	Color	Label	Description
D1	GREEN	48 V	48-V ON indicator
D13	BLUE	D13	Two-pair port 1 power is ON. For J19 supplier #1 (see the bill of materials (BOM)), J19 internal port LED is active. For supplier #2, D13 is active.
D15	BLUE	D15	Two-pair port 2 power is ON. For J20 supplier #1 (see the BOM), J20 internal port LED is active. For supplier #2, D15 is active.
D14	BLUE	D14	Two-pair port 3 power is ON. For J8 supplier #1 (see the BOM), J8 internal port LED is active. For supplier #2, D14 is active.
D12	BLUE	D12	Two-pair port 4 power is ON. For J7 supplier #1 (see the BOM), J7 internal port LED is active. For supplier #2, D12 is active.

Table 4. EVM LEDs (continued)

LED	Color	Label	Description
D19	BLUE	D19	Two-pair port 5 power is ON. For J32 supplier #1 (see the BOM), J32 internal port LED is active. For supplier #2, D19 is active.
D18	BLUE	D18	Two-pair port 6 power is ON. For J33 supplier #1 (see the BOM), J33 internal port LED is active. For supplier #2, D18 is active.
D17	BLUE	D17	Two-pair port 7 power is ON. For J21 supplier #1 (see the BOM), J21 internal port LED is active. For supplier #2, D17 is active.
D16	BLUE	D16	Two-pair port 8 power is ON. For J9 supplier #1 (see the BOM), J9 internal port LED is active. For supplier #2, D16 is active.
D3	GREEN	D3	Debug LED

3.3 EVM Test Points

[Table 5](#) lists and describes the EVM test points.

Table 5. EVM Test Points

TP	Color	Label	Description
Motherboard: BOOST-PSEMTHR8-097			
TP1	RED	VPWR	Used for VPWR
TP2	RED	3.3 V	Used for TPS23882 VDD
TP3	SMT	GND	VPWR ground
TP4	WHT	SDA	I ² C Data from LaunchPad and USB-TO-GPIO
TP5	WHT	SCL	I ² C Clock from LaunchPad and USB-TO-GPIO
TP6	WHT	PSE_SDAO	I ² C data out from TPS23882
TP7	WHT	PSE_SCL	I ² C clock to TPS23882
TP8	WHT	PSE_SDAI	I ² C data in to TPS23882
TP9	BLK	GND1	Ground from LaunchPad and USB2ANY
TP10	SMT	GND	VPWR ground test point
TP11	SMT	TP11	VPWR ground test point
TP12	SMT	GND	VPWR ground test point
TP13	SMT	GND	VPWR ground test point
Daughterboard: TPS23882EVM-008			
TP2	RED	2P4D	Two-pair port 4 DRAIN
TP3	WHT	2P4G	Two-pair port 4 GATE
TP4	WHT	2P5G	Two-pair port 5 GATE
TP5	RED	2P5D	Two-pair port 5 DRAIN
TP7	WHT	2P6G	Two-pair port 6 GATE
TP6	RED	2P6D	Two-pair port 6 DRAIN
TP1	BLK	GND	VPWR ground
TP8	SMT	GND	VPWR ground

3.4 EVM Test Jumpers

The EVM is equipped with shunts on the jumper positions identified in [Table 6](#), in the *Default Pin Position* column. Shunts can be moved and removed, as required, during use.

Table 6. EVM Jumpers

Jumper	Default Pin Position	Label	Description
Motherboard: BOOST-PSEMTHR8-097			

Table 6. EVM Jumpers (continued)

Jumper	Default Pin Position	Label	Description
J27	1-2	P1	Two-pair port 1 LED bias
J28	1-2	P2	Two-pair port 2 LED bias
J16	1-2	P3	Two-pair port 3 LED bias
J15	1-2	P4	Two-pair port 4 LED bias
J26	1-2	P5	Two-pair port 5 LED bias
J25	1-2	P6	Two-pair port 6 LED bias
J14	1-2	P7	Two-pair port 7 LED bias
J13	1-2	P8	Two-pair port 8 LED bias
Daughterboard: TPS23882EVM-008			
J4	1-2;3-4;5-6;7-8	A1;A2;A3;A4	I2C A1-A4 address lines
J5	3-4	2P-30W	AUTO pin selection (autonomous mode is enabled if connecting auto pin to ground with selected resistance, 2-pair 30W operation is selected by default)

4 TPS23882 GUI Setup

4.1 TPS23882 GUI Installation

TI's TPS23882 GUI is used with the TPS23882 to control the port and provide real-time feedback on port telemetry. Download the TPS23882 GUI from the [TPS23882 product folder page](#) in the *Tools and software* section.

Follow the onscreen instructions to complete the installation. The TPS23882 GUI uses the USB2ANY as an interface between the PC USB port and the BOOST-PSEMTHR8-097 J2 connector (I2C interface). Before starting the TPS23882 GUI, make sure the USB2ANY is properly connected to TPS23882 and the EVM is supplied with a 44- to 57-V power supply as shown in [Figure 2](#).

4.2 TPS23882GUI Operation

Start the TPS23882 GUI by double clicking the GUI icon. A window similar to [Figure 4](#) will come up.

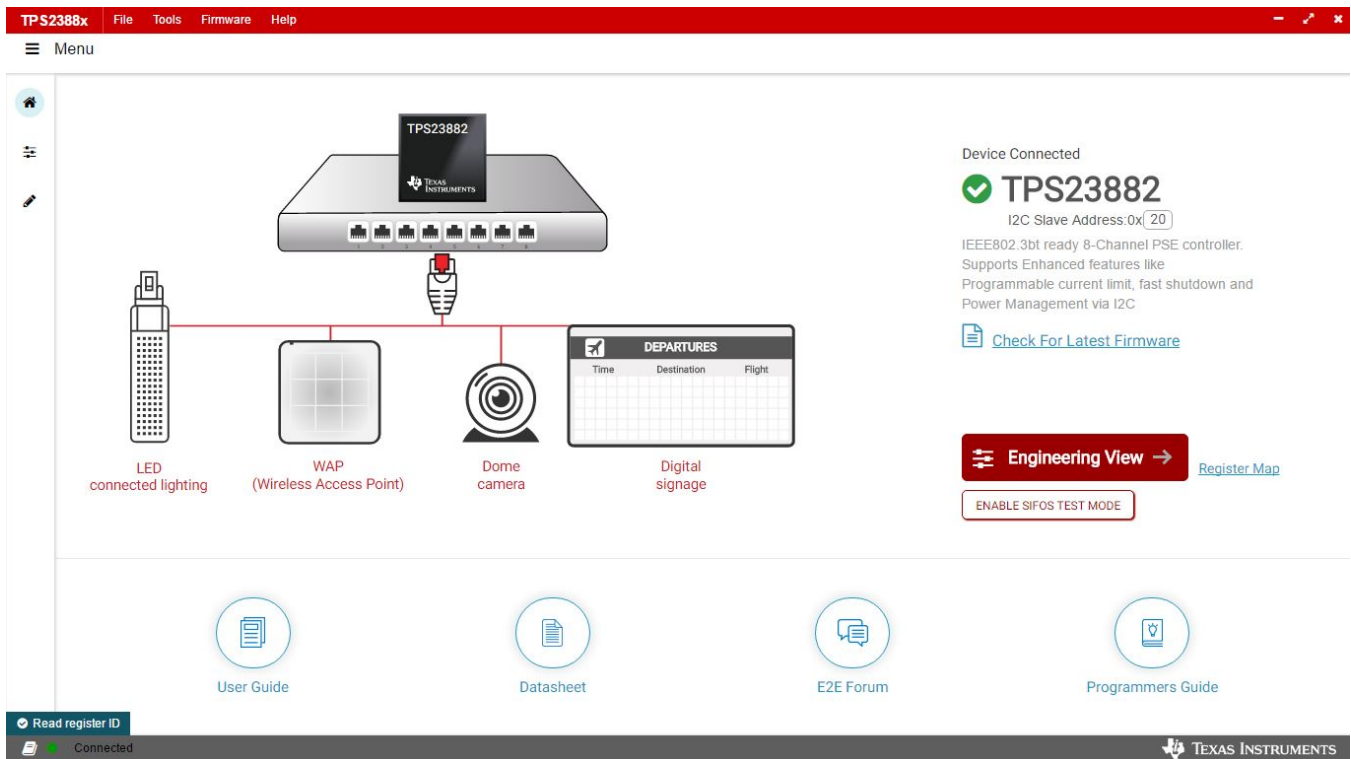

Figure 4. TPS23882 GUI Startup Window

The default device address in the GUI is set to 0x20 which matches the default configuration of the EVM (J4 on the daughter card is installed with jumpers). The GUI sets the TPS23882 in configuration B mode (see the *GENERAL MASK Register* section of the data sheet for details). The address can be programmed through the A1 to A4 pins and the I2C address setting in the GUI needs to match the hardware configuration. See the *Pin Status Register* section of the data sheet for details. The startup page contains links to the EVM user's guide, TPS23882 data sheet, E2E forum and MSP430 reference code. Four popular PD end-equipment images are connected to the PSE switch. Links to the recommended PD device for each end equipment are also provided.

Once the TPS23882 device is connected, click Firmware to select firmware to be loaded to TPS23882.

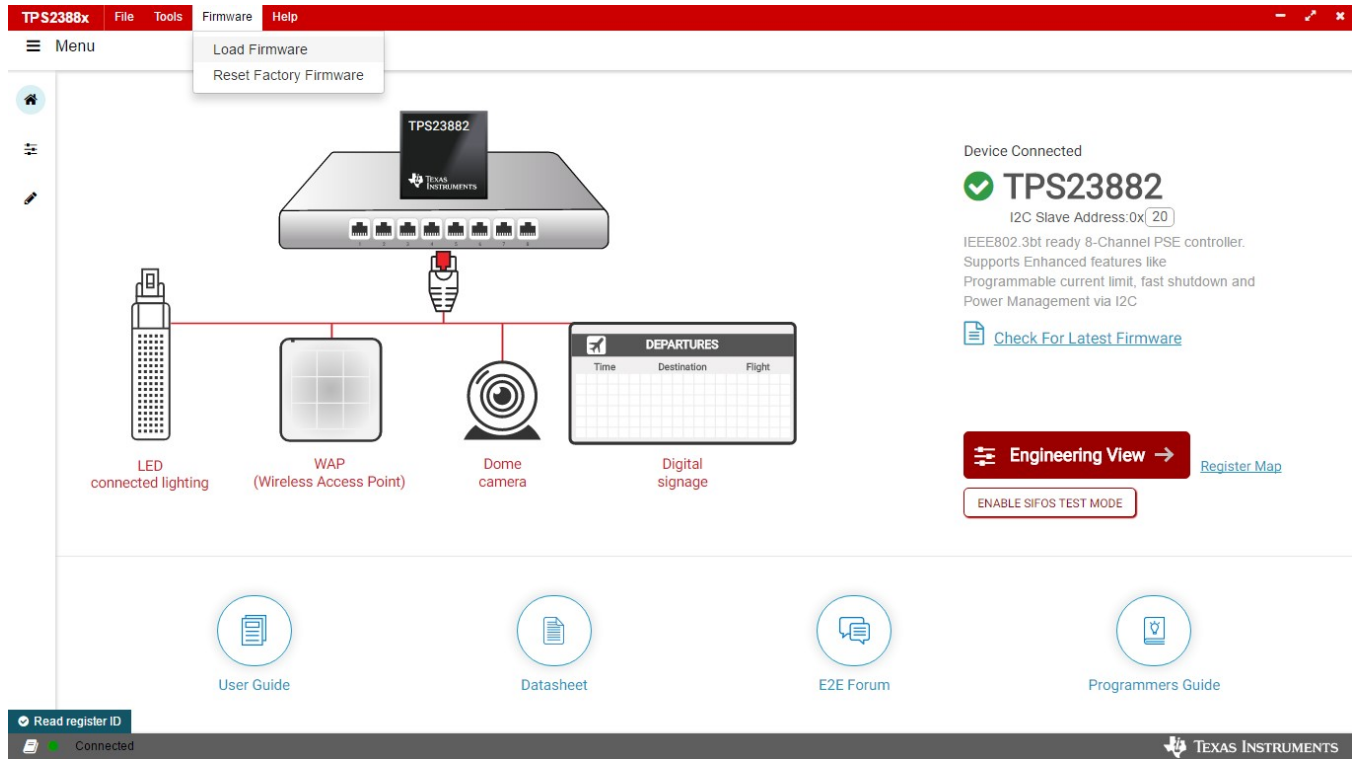

Figure 5. TPS23882 GUI Load Firmware 1

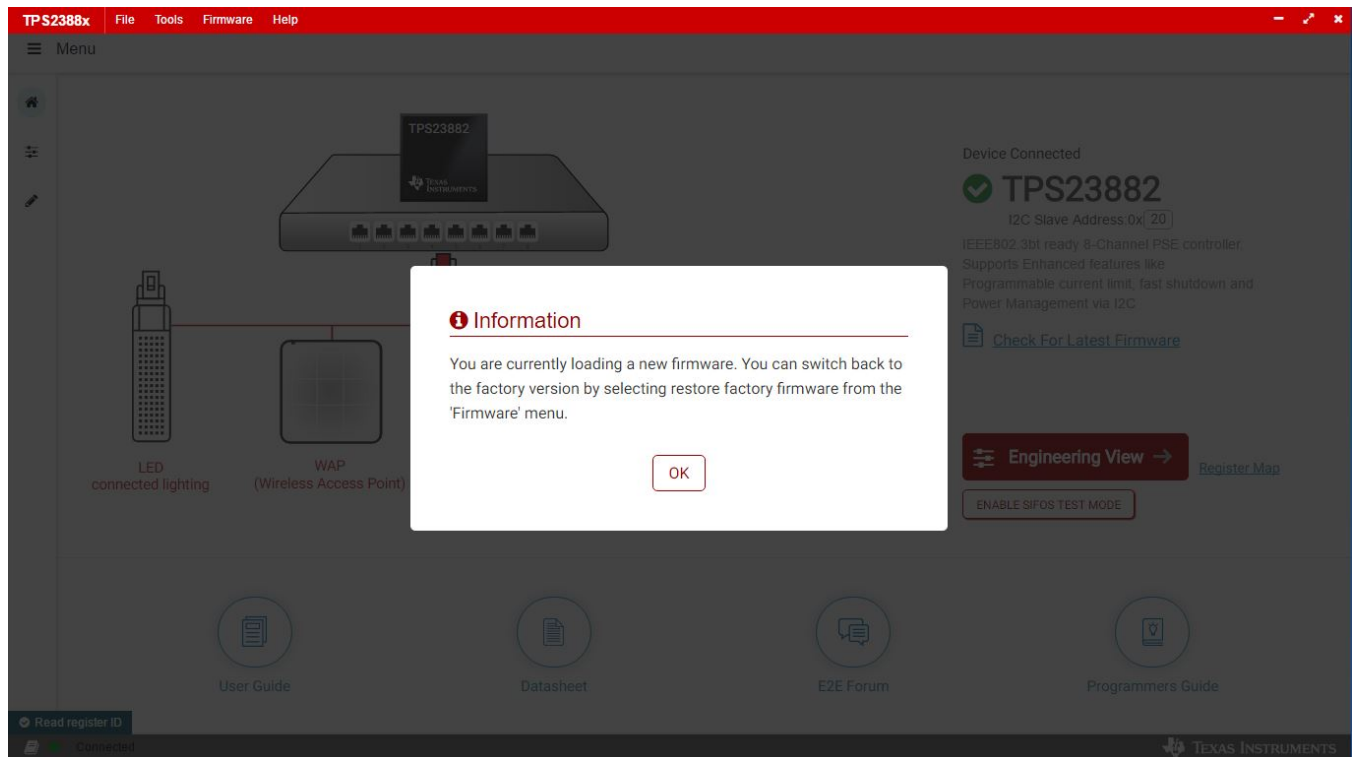

Figure 6. TPS23882 GUI Load Firmware 2

Once firmware is successfully loaded and *Device Connected* displays and port configuration type is selected, click *Engineering View*.

On the page displayed in [Figure 7](#), each port can be configured separately by clicking each RJ45 connector. By default, the TPS23882 is configured in OFF Mode. Each port can be configured by clicking the RJ45 icon. Clicking the *SET ALL PORTS TO STANDARD* button sets all port to standard configurations (configuring ports in Semi-Auto mode, enabling OSS, power policing, and DC disconnect). Clicking the *SET ALL PORTS TO AUTO MODE* button enables *Auto Mode* for all ports.

The status of each port is shown on the configuration and telemetry page. The configuration of the ports can also be edited on this page by clicking the RJ45 connector.

If the port is configured in *Auto Mode*, the port will turn on automatically by the PSE device after connecting a valid PD. If not configured in *Auto Mode*, a port enable command is required. The port can be turned on only when the PD has valid detection and classification results.

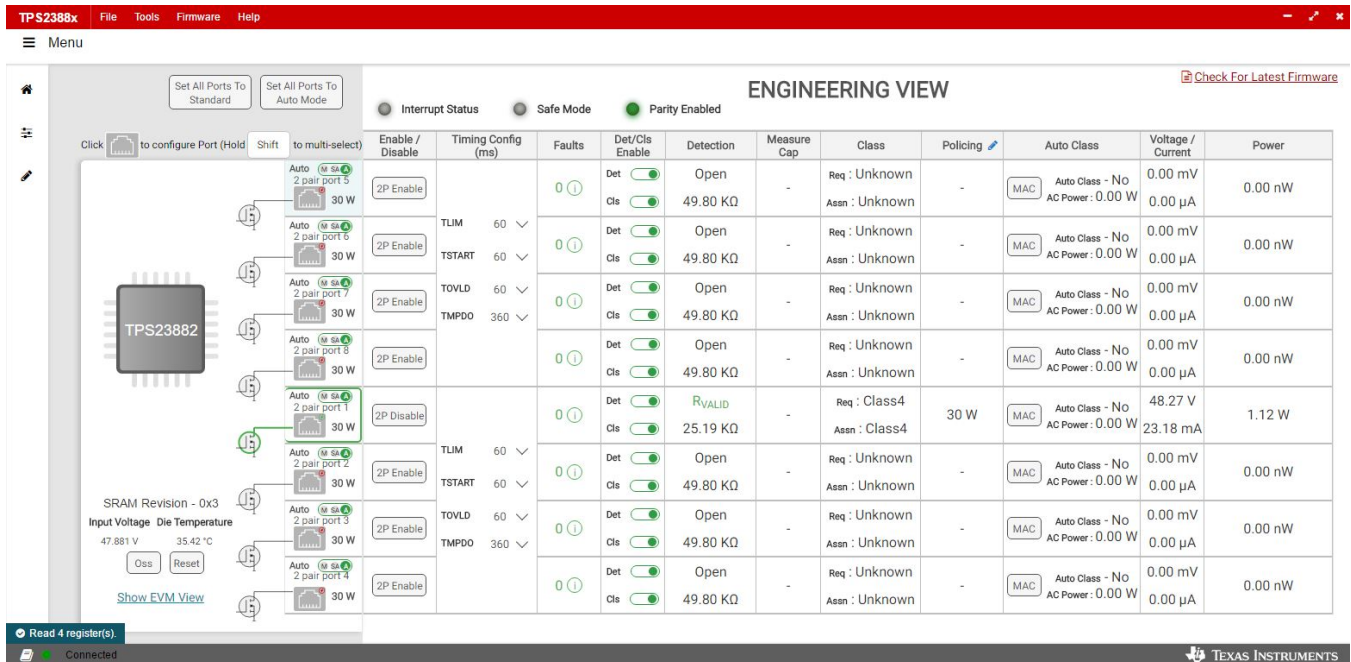

Figure 7. Device Configuration and Port Telemetry Page

The GUI also provides access to every register of the device in the register map.

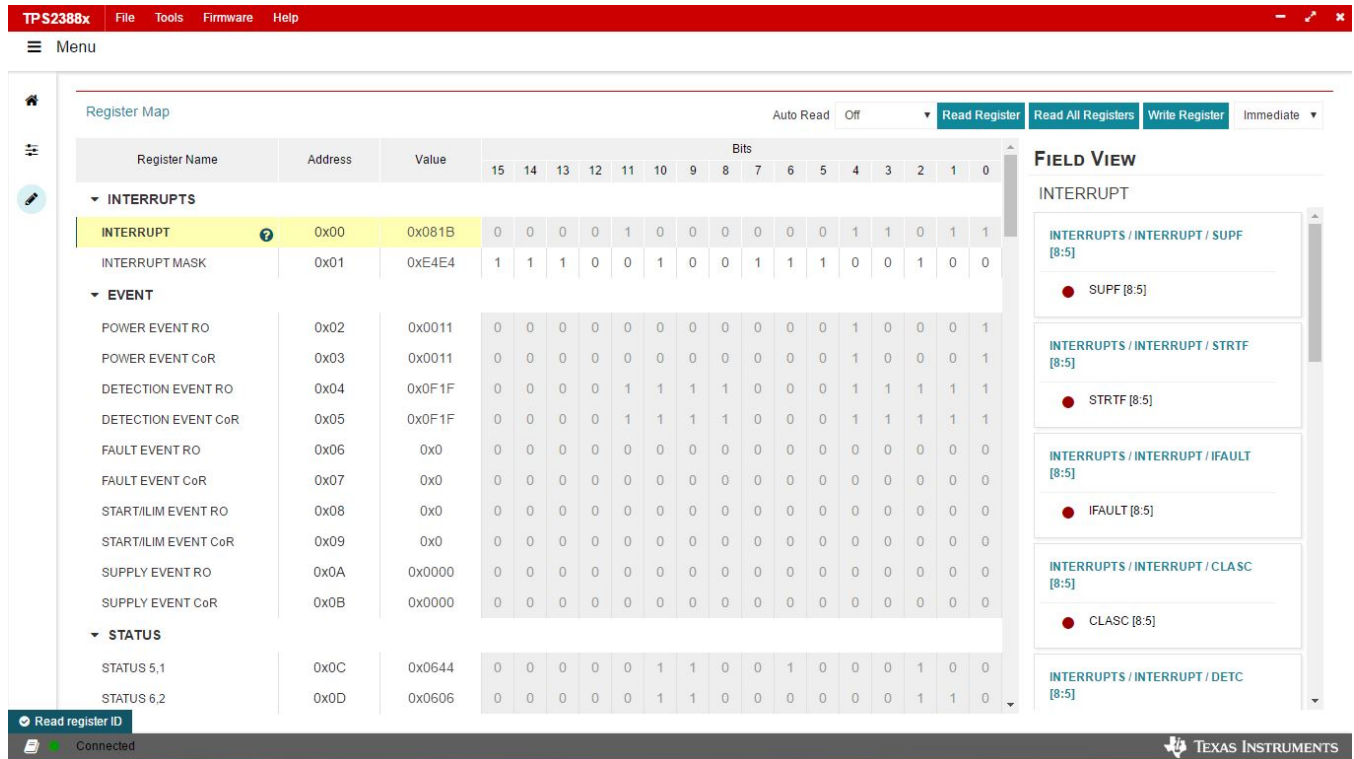

Figure 8. Register Map

4.3 MSP-EXP430FR5969 Details

The TPS23882 accepts the MSP-EXP430FR5969 evaluation module when the application requires management of the TPS23882 devices with an external controller.

1. Install MSP-EXP430FR5969 onto BOOST-PSEMTHR8-097 and ensure that the USB2ANY ribbon cable is NOT installed into J2.
2. Connect the PC to the LaunchPad as shown in [Figure 3](#).
3. The source code was developed for the MSP430 LaunchPad Development Kit (MSP-EXP430GFR5969) using the Code Composer Studio™ (CCS) version 7.2.0 development environment. The target MSP430 can be programmed within this environment.
4. Once CCS is installed, use the basic set of instructions listed in [Section 4.3.1](#) to import, build, and run the project. CCS version 7.2.0 is used in the following examples. Note that a terminal program such as HyperTerminal or Teraterm is required to view the output from the EVM when it is running.

4.3.1 Basic CCS and Terminal Setup

Use the following steps for basic CCS and terminal setup:

1. Launch the CCS program on the PC: *Start* → *Texas Instruments* → *Code Composer Studio 7.2.0* → *Code Composer Studio 7.2.0*.
2. OK the workspace location and CCS starts.
3. Import the project: *Project* → *Import CCS Projects* (make sure you are in CCS Edit mode).
4. Navigate to the project location, then click the *Finish* button.
5. Build the project by clicking the hammer symbol. Semi-Auto or Auto mode can be switched selected using the drop-down arrow to the right of the hammer symbol.
6. Launch the debug session from CCS to activate the current project: Run, Debug (or F11).
7. Run the active project: Run, Resume (or play button, F8).
8. Determine the PC COM port connected to the LaunchPad by going into the *Device Manager Ports* (COM and LPT) section. Launch the terminal program.
9. Once the terminal program is properly connected to the LaunchPad running the PoE firmware, then text similar to the following image appears.

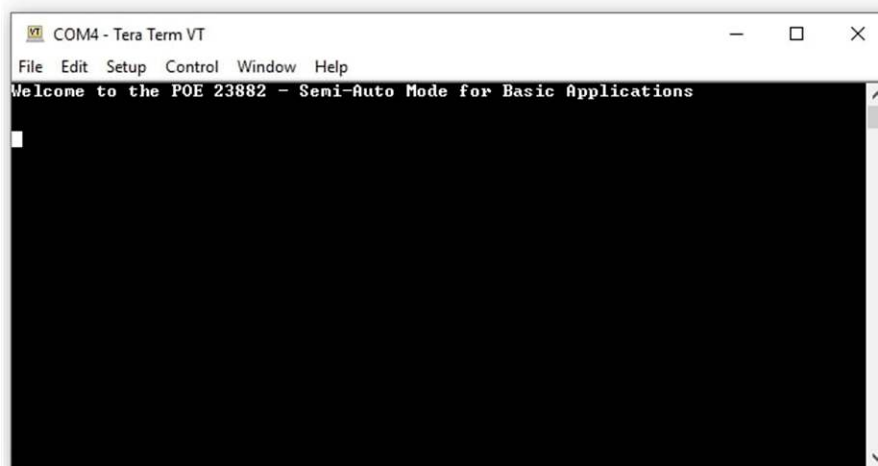
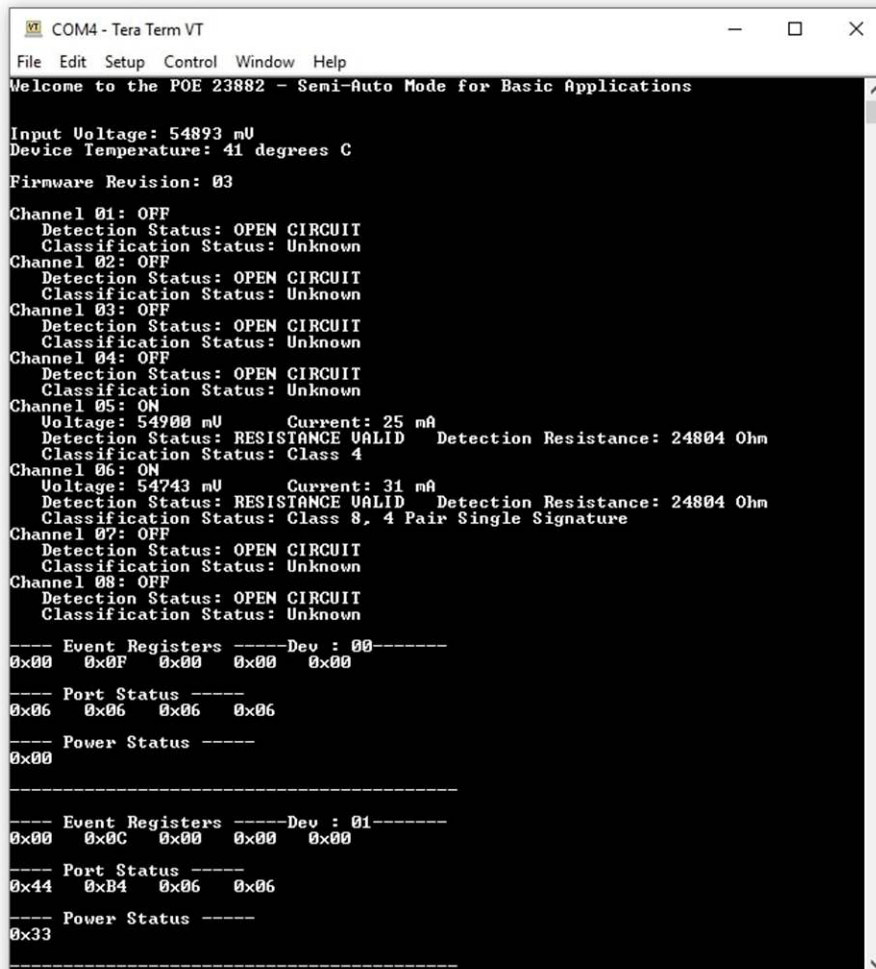

Figure 9. Semi-Auto UART Transmission Startup

- The TPS23882 is now waiting for a PD load to be installed. As ports are installed, the system automatically detects, classifies, and powers up the port as shown in [Figure 10](#). Port status is updated on the screen approximately every 10 seconds.



```

COM4 - Tera Term VT
File Edit Setup Control Window Help
Welcome to the POE 23882 - Semi-Auto Mode for Basic Applications

Input Voltage: 54893 mV
Device Temperature: 41 degrees C
Firmware Revision: 03

Channel 01: OFF
  Detection Status: OPEN CIRCUIT
  Classification Status: Unknown
Channel 02: OFF
  Detection Status: OPEN CIRCUIT
  Classification Status: Unknown
Channel 03: OFF
  Detection Status: OPEN CIRCUIT
  Classification Status: Unknown
Channel 04: OFF
  Detection Status: OPEN CIRCUIT
  Classification Status: Unknown
Channel 05: ON
  Voltage: 54900 mV      Current: 25 mA
  Detection Status: RESISTANCE VALID  Detection Resistance: 24804 Ohm
  Classification Status: Class 4
Channel 06: ON
  Voltage: 54743 mV      Current: 31 mA
  Detection Status: RESISTANCE VALID  Detection Resistance: 24804 Ohm
  Classification Status: Class 8, 4 Pair Single Signature
Channel 07: OFF
  Detection Status: OPEN CIRCUIT
  Classification Status: Unknown
Channel 08: OFF
  Detection Status: OPEN CIRCUIT
  Classification Status: Unknown

--- Event Registers ---Dev : 00-----
0x00  0x0F  0x00  0x00  0x00

--- Port Status ---
0x06  0x06  0x06  0x06

--- Power Status ---
0x00

-----
--- Event Registers ---Dev : 01-----
0x00  0x0C  0x00  0x00  0x00

--- Port Status ---
0x44  0xB4  0x06  0x06

--- Power Status ---
0x33
  
```

Figure 10. Semi-Auto UART Transmission Status

4.4 MSP430 Reference Code

4.4.1 Overview

There is MSP430 reference code for basic applications published on ti.com. This reference code will be discussed in the following sections.

The system software supports the following features:

- IEEE802.3bt PoE specification
- Device detection, connection check, and classification
- Automatic power on (standard 2-pair PDs)
- DC disconnect
- Port telemetry updates

The MSP430 communicates with the PC through UART, reporting the parameter and status of the port.

4.4.2 Auto Mode

Auto mode operation is demonstrated in the MSP430 reference code and [Figure 11](#) shows the flow chart. Basically, after configuration, the TPS23882 handles port detection, classification, turn on, and faults by itself and there is no control needed from the host.

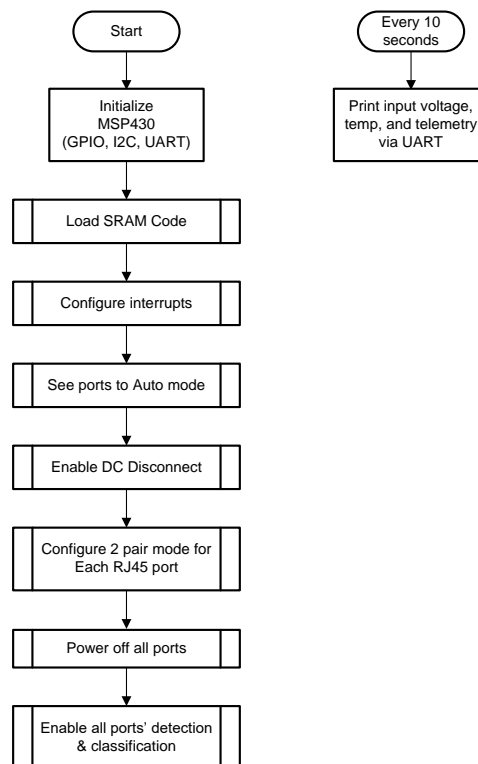

Figure 11. Auto Mode System Software Structure

4.4.3 Semi Auto Mode

Operation, the semi auto mode reference code is interrupt based. When MSP430 receives an interrupt from PSE's INT pin, the code checks interrupt the register and event registers to proceed with actions accordingly. The flowchart of semi auto mode code is shown in [Figure 12](#).

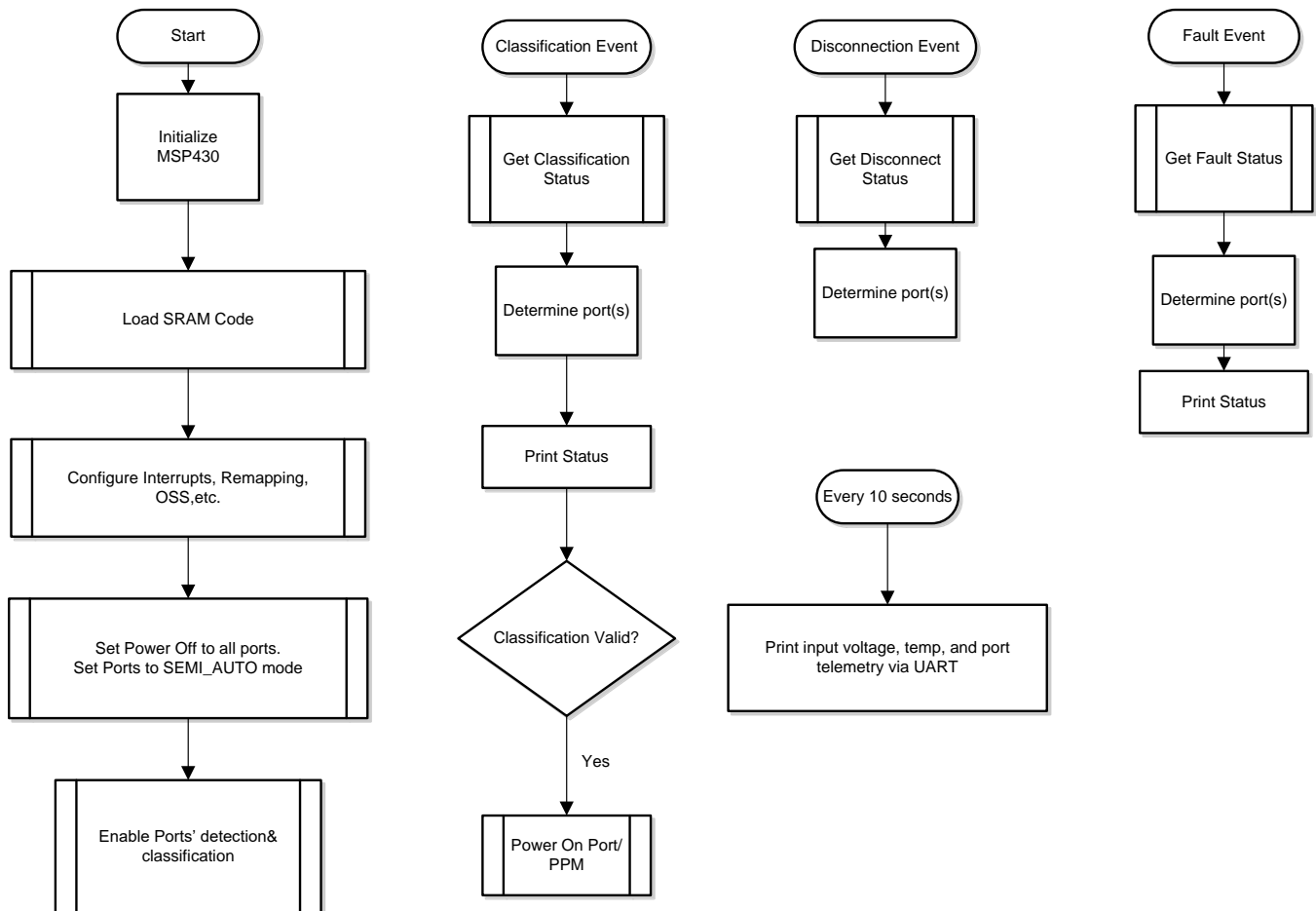

Figure 12. Semi Auto Mode System Software Structure

5 EVM Schematic, Layout Guidelines, PCB Assembly and Layer Plots

This section contains the TPS23882 schematic, layout guidelines, printed-circuit board (PCB) assembly and layer plots.

5.1 Schematic

[Figure 13](#) through [Figure 15](#) illustrate the TPS23882 (daughter card+motherboard) schematics.

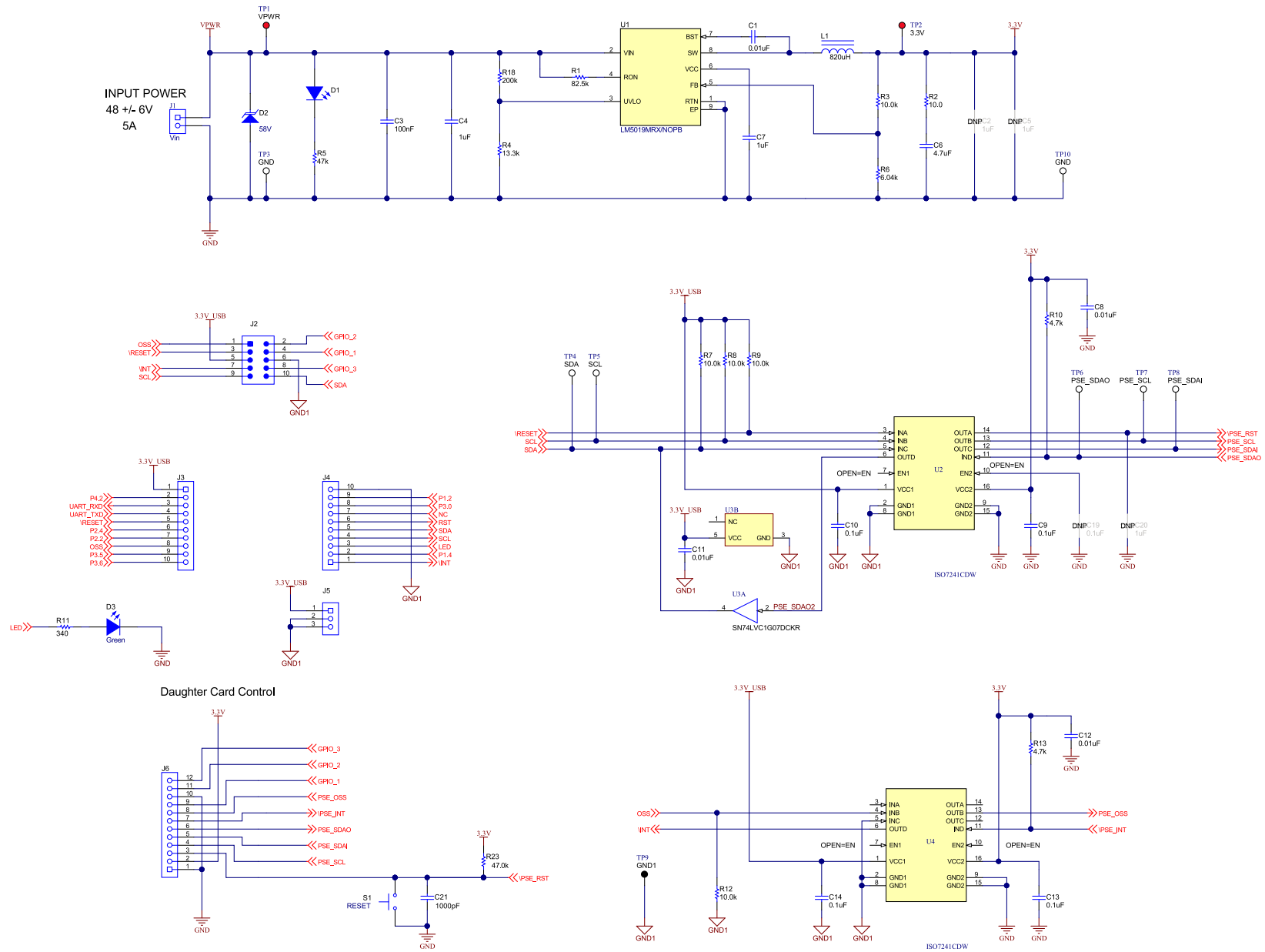

Figure 13. BOOST-PSEMTHR8-097 (Motherboard) Schematic: Control

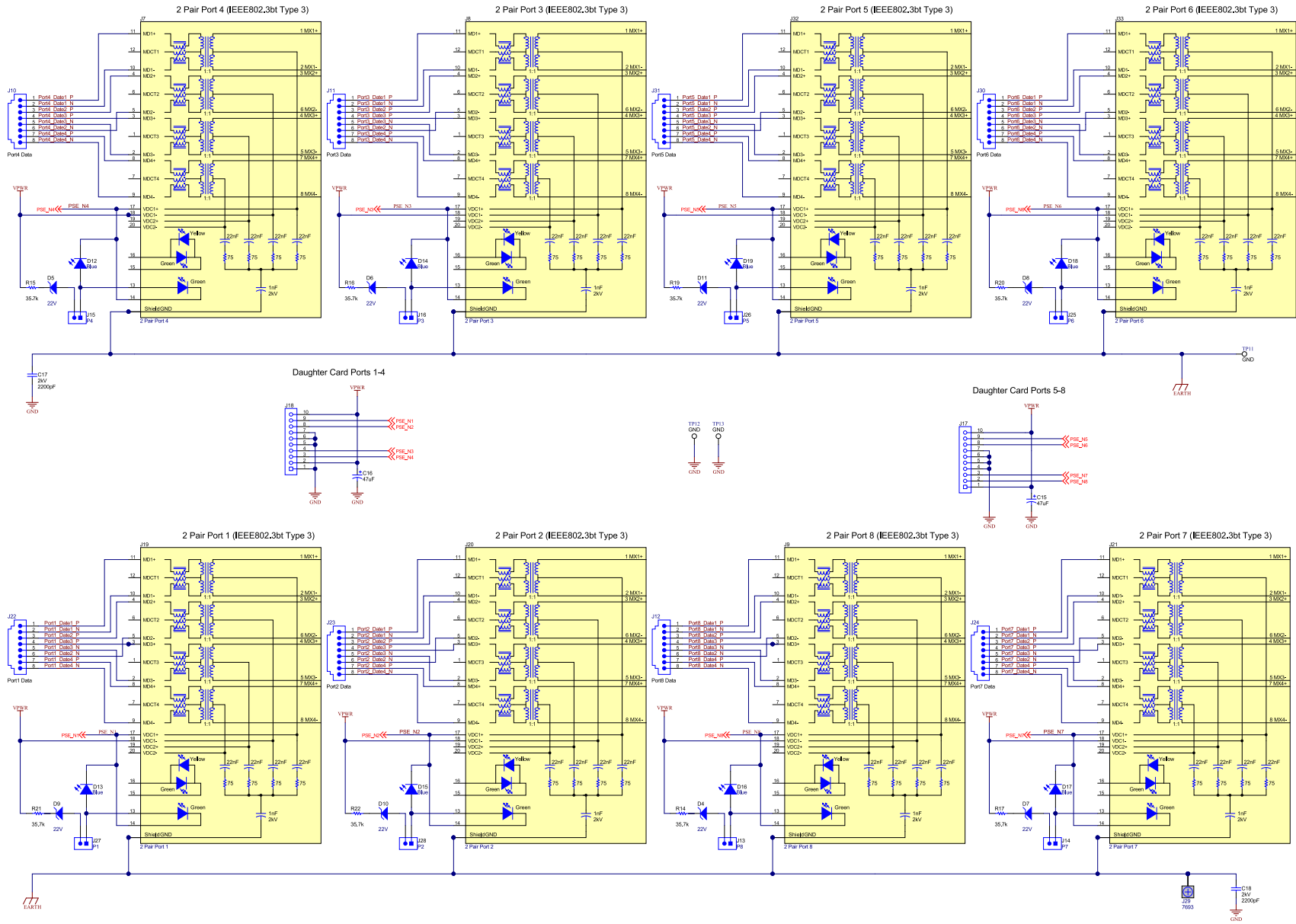

Figure 14. BOOST-PSEMTHR8-097 (Motherboard) Schematic: Power Ports

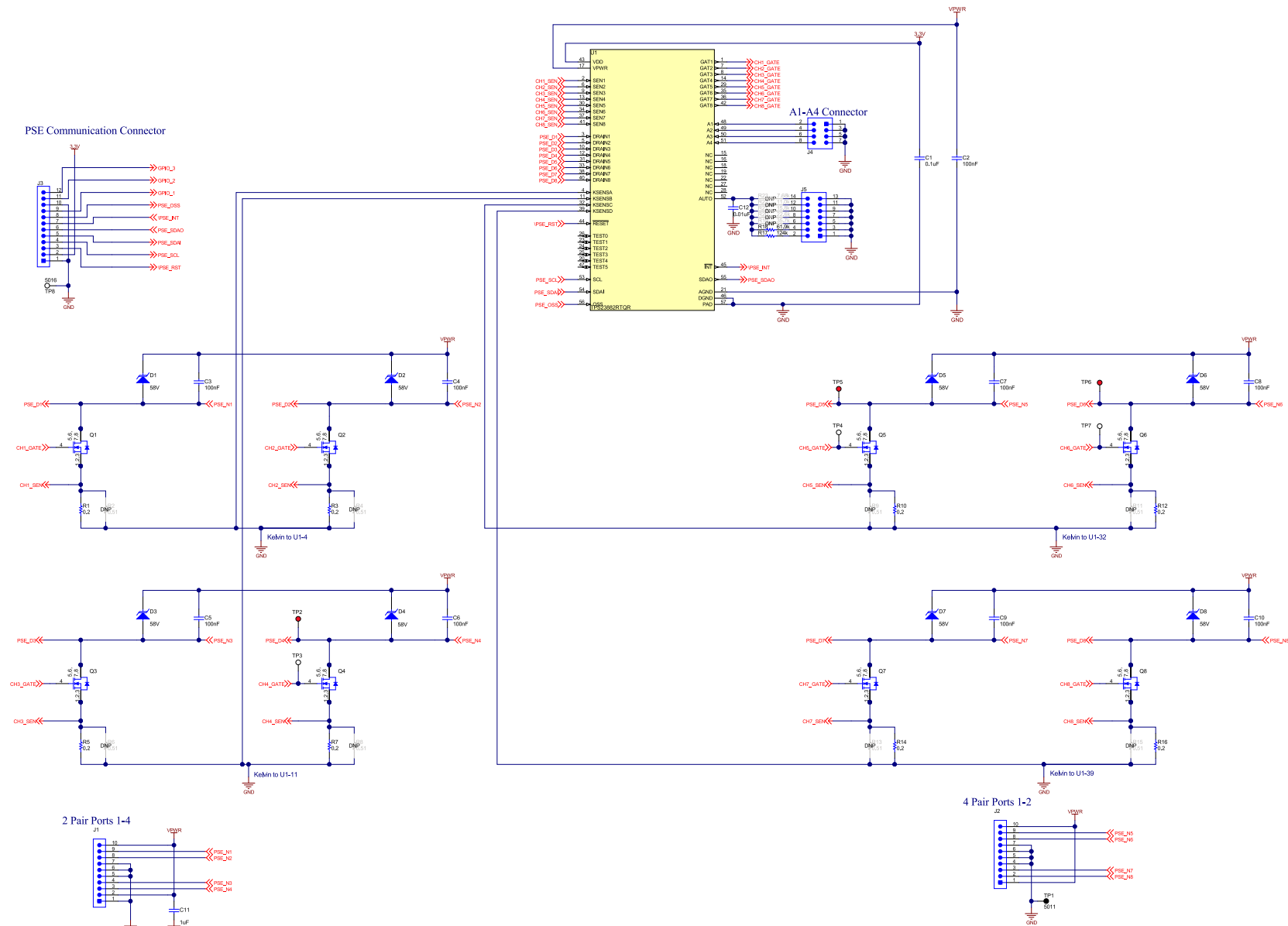

Figure 15. TPS23882EVM-008 (Daughterboard) Schematic

5.2 Layout Guidelines

5.2.1 Supply Voltage Decoupling

Provide power supply pin bypass to the TPS23882 device as follows:

- 0.1 μ F, 100 V, X7R ceramic at pin 28 (VPWR)
- 0.1 μ F, 50 V, X7R ceramic at pin 1 (VDD)

5.2.2 Port Current Kelvin Sensing

KSENSA is shared between SEN1 and SEN2, while KSENSB is shared between SEN3 and SEN4. In order to optimize the accuracy of the measurement, the PCB layout must be done carefully to minimize the impact of PCB trace resistance. Refer to [Figure 22](#) as an example.

5.2.3 Ground Plane Spacing and Isolation (GND, GND1, and EARTH nets)

Appropriate spacing should be provided between the GND, GND1, and EARTH nets as shown in [Figure 18](#).

5.3 PCB Drawings

[Figure 16](#) through [Figure 24](#) show the PCB layouts and assemblies for this EVM.

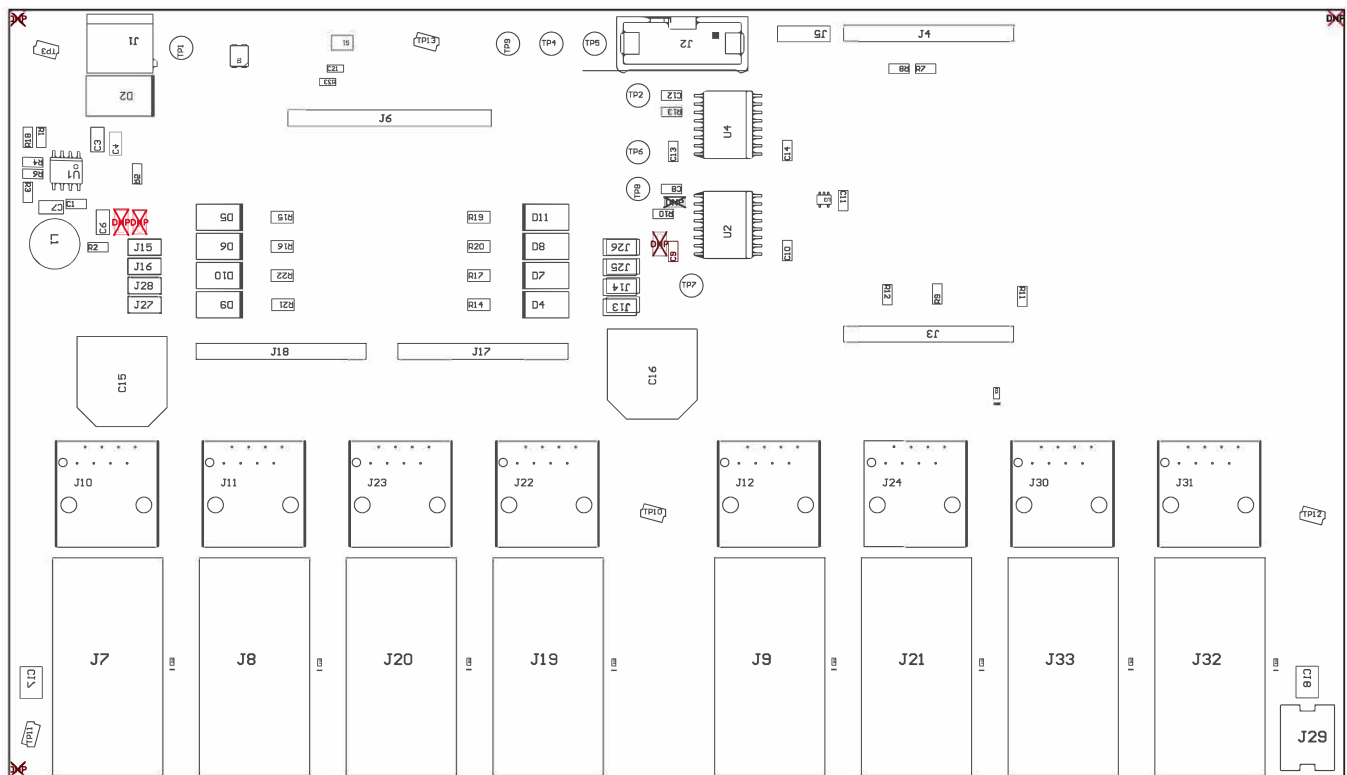

Figure 16. BOOST-PSEMTHR8-097 (Motherboard) Top Side Assembly

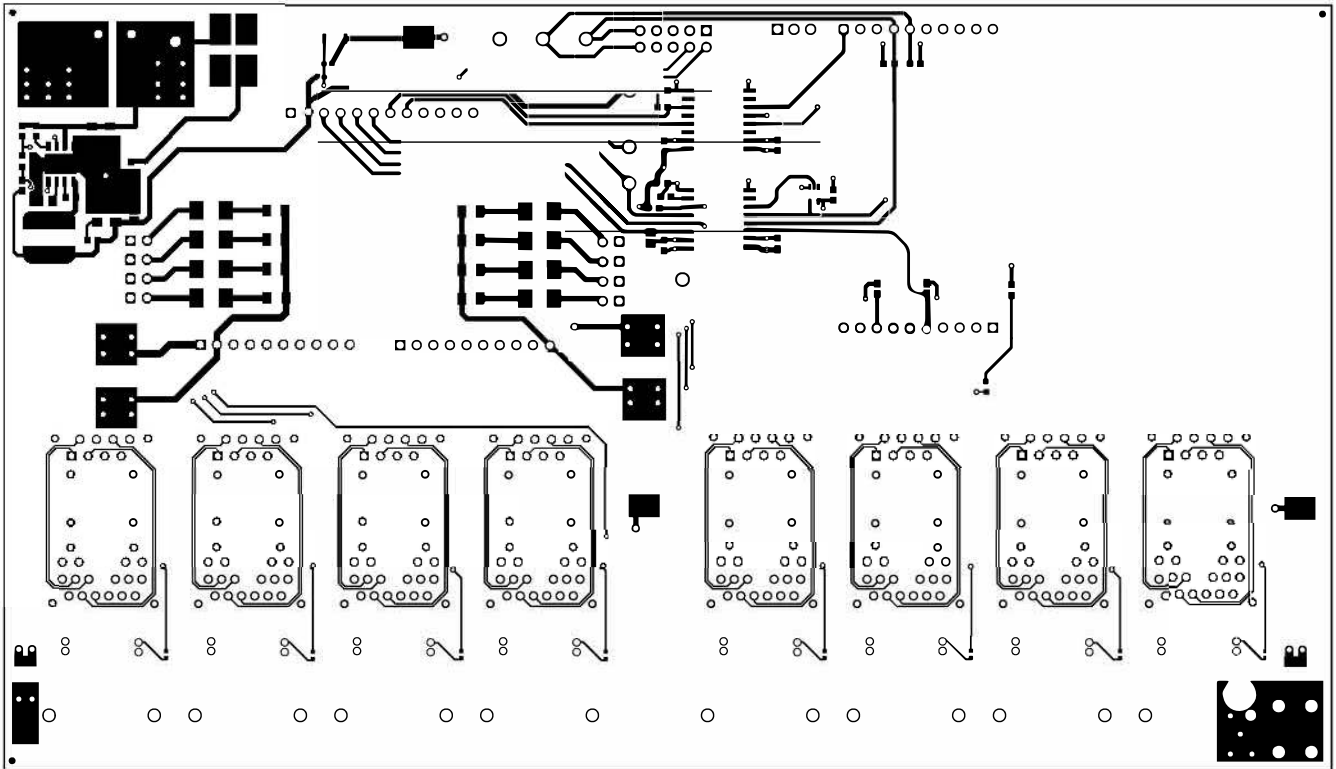

Figure 17. BOOST-PSEMTHR8-097 (Motherboard) Top Side Routing

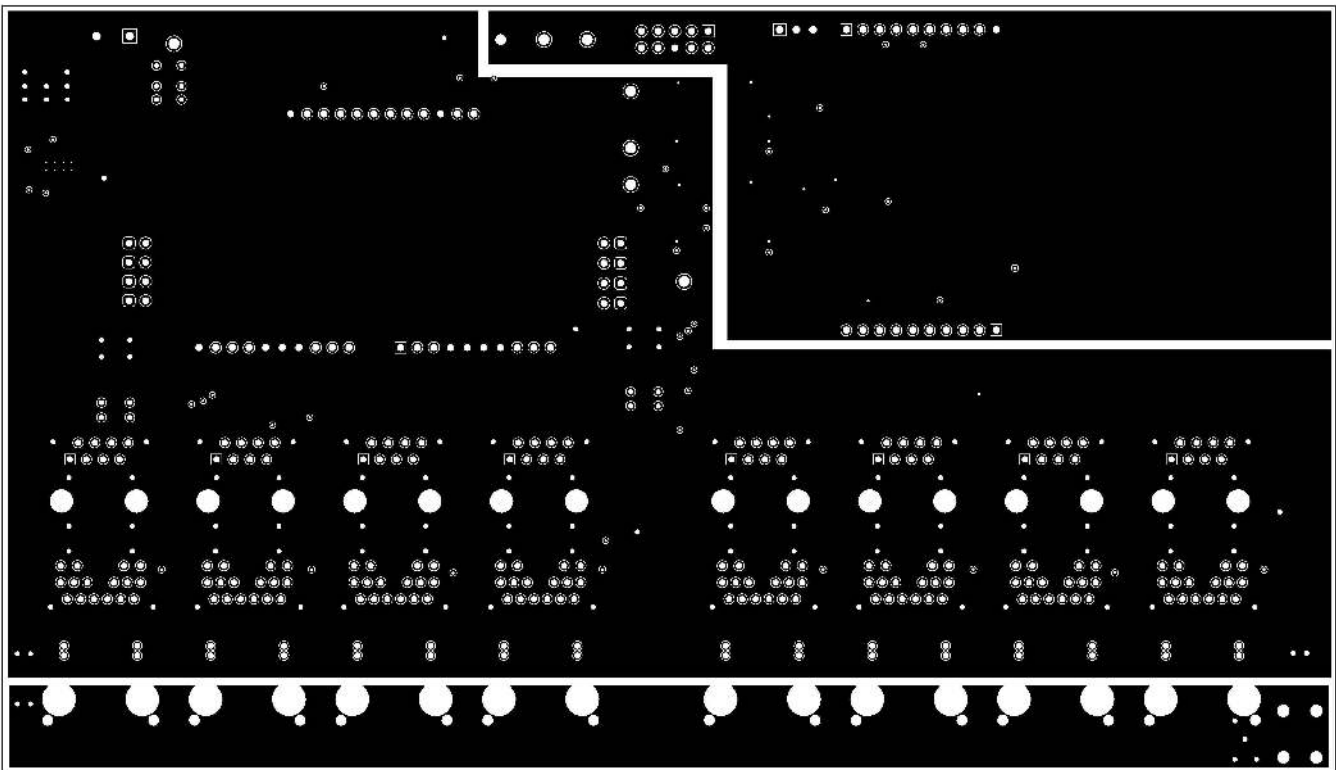

Figure 18. BOOST-PSEMTHR8-097 (Motherboard) Layer 2 Routing

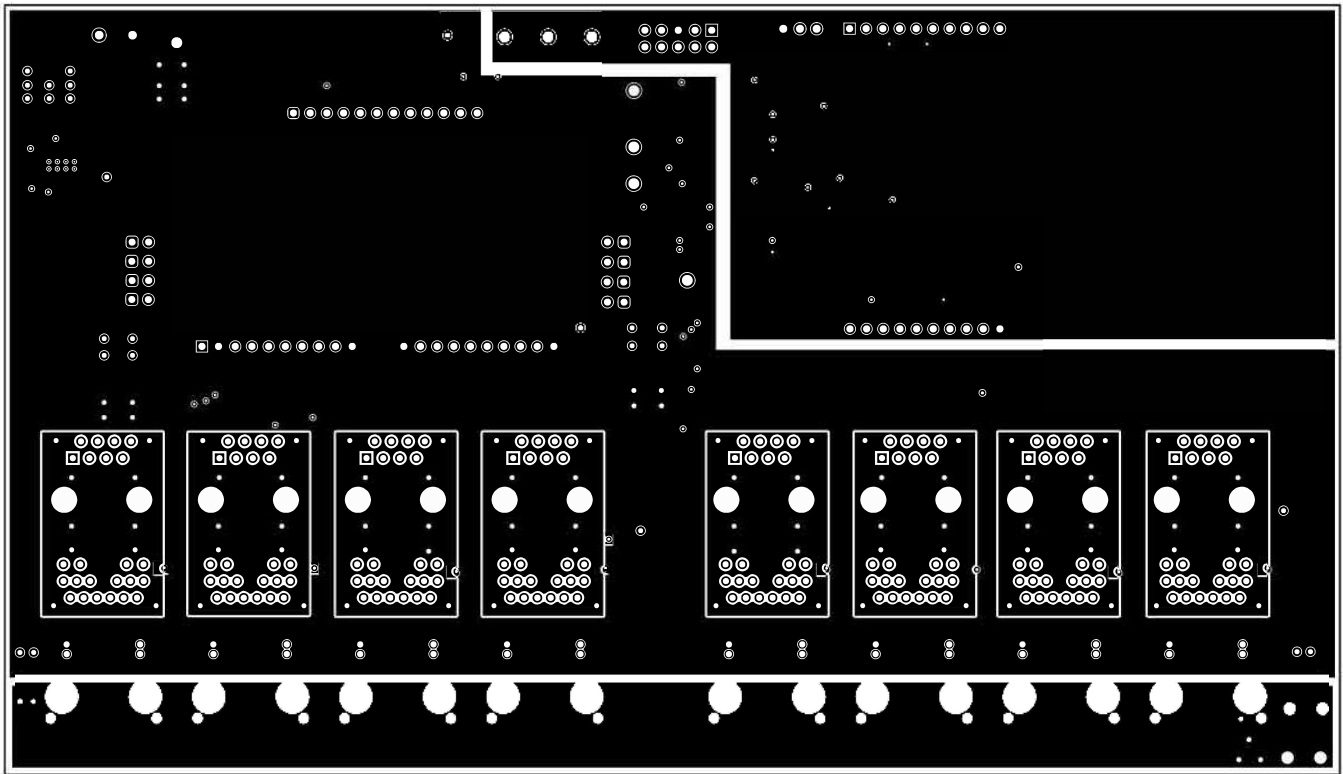

Figure 19. BOOST-PSEMTHR8-097 (Motherboard) Layer 3 Routing

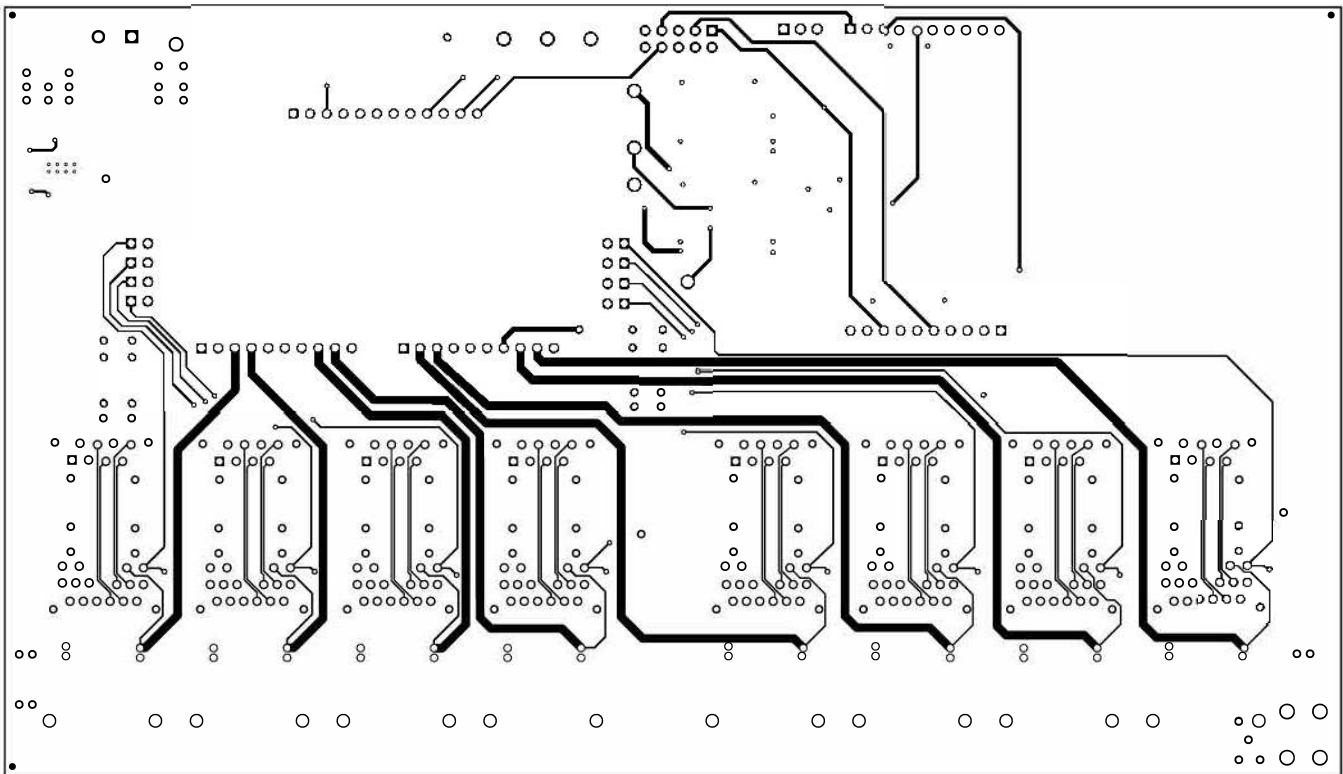

Figure 20. BOOST-PSEMTHR8-097 (Motherboard) Bottom Side Routing

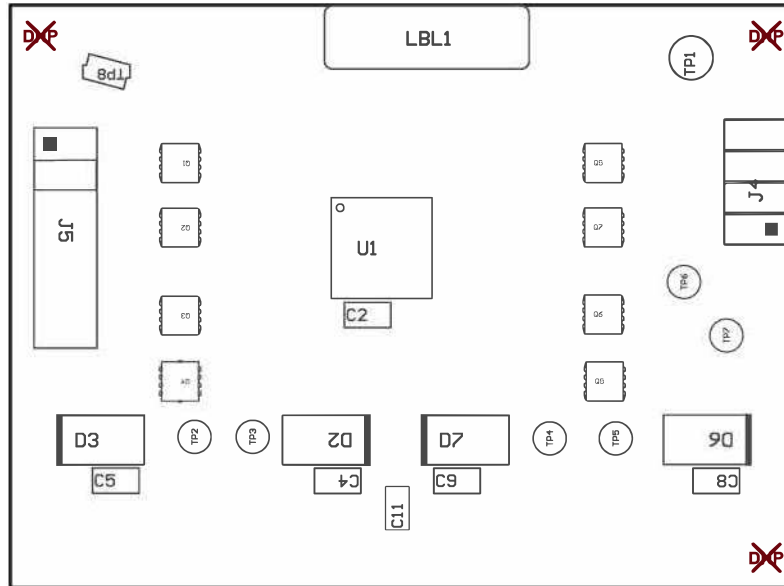

Figure 21. TPS23882EVM-008 (Daughterboard) Top Side Assembly

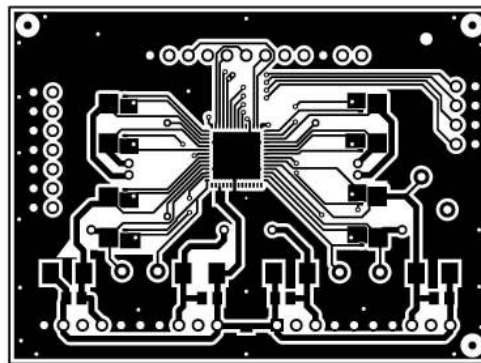

Figure 22. TPS23882EVM-008 (Daughterboard) Top Side Routing

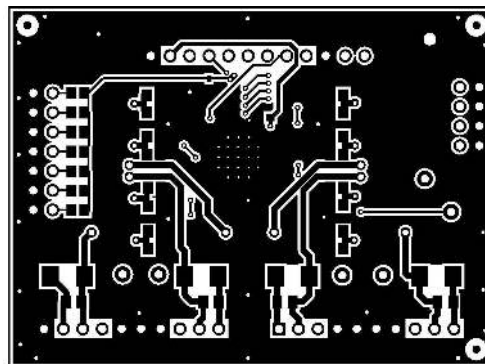

Figure 23. TPS23882EVM-008 (Daughterboard) Bottom Side Routing

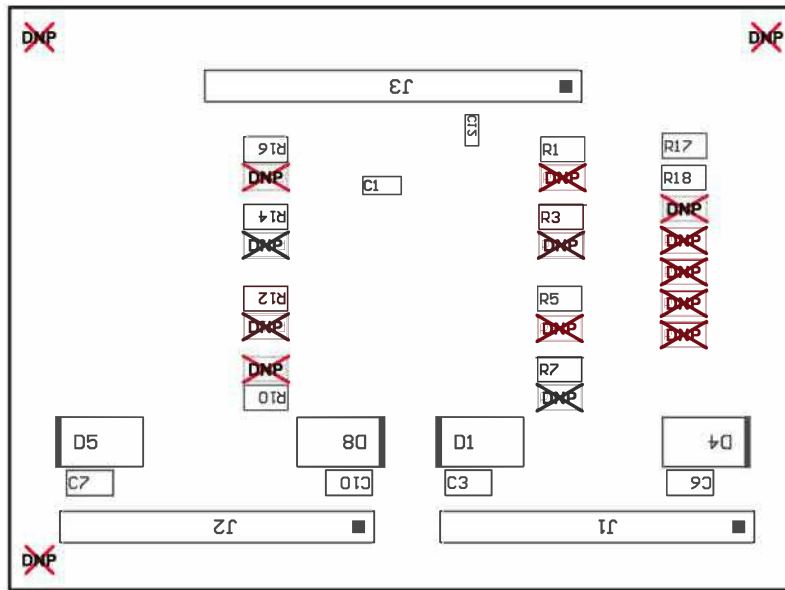

Figure 24. TPS23882EVM-008 (Daughterboard) Bottom Side Assembly

6 Bill of Materials

The BOMs for the BOOST-PSEMTHR8-097 and TPS23882EVM-008 are listed in [Table 7](#) and [Table 8](#).

Table 7. BOOST-PSEMTHR8-097 Bill of Materials⁽¹⁾

Designator	Quantity	Value	Description	PackageReference	PartNumber	Manufacturer	Alternate PartNumber	Alternate Manufacturer
!PCB	1		Printed Circuit Board		PSIL097	Any		
C1, C8, C11, C12	4	0.01uF	CAP, CERM, 0.01 uF, 100 V, +/- 10%, X7R, 0603	0603	06031C103KAT2A	AVX		
C3	1	0.1uF	CAP, CERM, 0.1 uF, 100 V, +/- 10%, X7R, 0805	0805	C2012X7R2A104K125AA	TDK		
C4	1	1uF	CAP, CERM, 1 uF, 100 V, +/- 10%, X7R, 1206	1206	CL31B105KCHNNE	Samsung		
C6	1	4.7uF	CAP, CERM, 4.7 uF, 10 V, +/- 10%, X5R, 0805	0805	C0805C475K8PACTU	Kemet		
C7	1	1uF	CAP, CERM, 1 uF, 10 V, +/- 10%, X7R, 0805	0805	0805ZC105KAT2A	AVX		
C9, C10, C13, C14	4	0.1uF	CAP, CERM, 0.1 uF, 50 V, +/- 10%, X7R, 0603	0603	06035C104KAT2A	AVX		
C15, C16	2	47uF	CAP, AL, 47 uF, 100 V, +/- 20%, 0.32 ohm, AEC-Q200 Grade 2, SMD	SMT Radial H13	EEV-FK2A470Q	Panasonic		
C17, C18	2	2200pF	CAP, CERM, 2200 pF, 2000 V, +/- 10%, X7R, 1812	1812	C4532X7R3D222K130KA	TDK		
C21	1	1000pF	CAP, CERM, 1000 pF, 50 V, +/- 10%, X7R, 0402	0402	885012205061	Würth Elektronik		
D1	1	White	LED, True Green, SMD	2.8x3.2mm	LT E6SG-AABB-35-1	OSRAM		
D2	1	58V	Diode, TVS, Uni, 58 V, 93.6 Vc, SMC	SMC	SMCJ58A-13-F	Diodes Inc.		
D3	1	Green	LED, Green, SMD	1.6x0.8x0.8mm	LTST-C190KGKT	Lite-On		
D4, D5, D6, D7, D8, D9, D10, D11	8	22V	Diode, Zener, 22 V, 550 mW, SMB	SMB	1SMB5933BT3G	ON Semiconductor		
D12, D13, D14, D15, D16, D17, D18, D19	8	Blue	LED, Blue, SMD	1x0.5mm	LB QH9G-N100-35-1	OSRAM		
H1, H2, H3, H4, H5, H6, H7, H8, H9	9		Bumpon, Cylindrical, 0.312 X 0.200, Black	Black Bumpon	SJ61A1	3M		
J1	1		Terminal Block, 5.08 mm, 2x1, Brass, TH	2x1 5.08 mm Terminal Block	ED120/2DS	On-Shore Technology		
J2	1		Header (shrouded), 100mil, 5x2, High-Temperature, Gold, TH	5x2 Shrouded header	N2510-6002-RB	3M		
J3, J4, J17, J18	4		Receptacle, 2.54mm, 10x1, Tin, TH	Receptacle, 2.54mm, 10x1, TH	SSW-110-01-T-S	Samtec		
J5	1		Receptacle, 100mil, 3x1, Gold, TH	3x1 Receptacle	SSW-103-01-G-S	Samtec		
J6	1		Receptacle, 2.54mm, 12x1, Gold, TH	Receptacle, 2.54mm, 12x1, TH	PPPC121LFBN-RC	Sullins Connector Solutions		
J7, J8, J9, J19, J20, J21, J32, J33	8		RJ45 with integrated magnetics	RJ-45 Jack	JK0-0177NL	Pulse Engineering		
J10, J11, J12, J22, J23, J24, J30, J31	8		RJ45, Vertical, TH	RJ-45 Jack, 8Pos Right Angle	SS-7188V-A-NF	Stewart Connector		

⁽¹⁾ Unless otherwise noted in the *Alternate Part Number* or *Alternate Manufacturer* columns, all parts may be substituted with equivalents.

Table 7. BOOST-PSEMTHR8-097 Bill of Materials⁽¹⁾ (continued)

Designator	Quantity	Value	Description	PackageReference	PartNumber	Manufacturer	Alternate PartNumber	Alternate Manufacturer
J13, J14, J15, J16, J25, J26, J27, J28	8		Header, 100mil, 2x1, Gold, TH	2x1 Header	TSW-102-07-G-S	Samtec		
J29	1		Terminal screw, vertical, snap-in	7693	7693	Keystone		
L1	1	820uH	Inductor, Drum Core, Ferrite, 820 uH, 0.23 A, 4 ohm, SMD	SDR0805	SDR0805-821KL	Bourns	768775282	Würth Electronics
R1	1	82.5k	RES, 82.5 k, 1%, 0.1 W, AEC-Q200 Grade 0, 0603	0603	CRCW060382K5FKEA	Vishay-Dale		
R2	1	10.0	RES, 10.0, 1%, 0.1 W, AEC-Q200 Grade 0, 0603	0603	CRCW060310R0FKEA	Vishay-Dale		
R3, R7, R8, R9, R12	5	10.0k	RES, 10.0 k, 1%, 0.1 W, AEC-Q200 Grade 0, 0603	0603	CRCW060310K0FKEA	Vishay-Dale		
R4	1	13.3k	RES, 13.3 k, 1%, 0.1 W, AEC-Q200 Grade 0, 0603	0603	CRCW060313K3FKEA	Vishay-Dale		
R5	1	47k	RES, 47 k, 5%, 0.1 W, AEC-Q200 Grade 0, 0603	0603	CRCW060347K0JNEA	Vishay-Dale		
R6	1	6.04k	RES, 6.04 k, 1%, 0.1 W, AEC-Q200 Grade 0, 0603	0603	CRCW06036K04FKEA	Vishay-Dale		
R10, R13	2	4.7k	RES, 4.7 k, 5%, 0.1 W, AEC-Q200 Grade 0, 0603	0603	CRCW06034K70JNEA	Vishay-Dale		
R11	1	340	RES, 340, 1%, 0.1 W, AEC-Q200 Grade 0, 0603	0603	CRCW0603340RFKEA	Vishay-Dale		
R14, R15, R16, R17, R19, R20, R21, R22	8	35.7k	RES, 35.7 k, 1%, 0.25 W, AEC-Q200 Grade 0, 1206	1206	CRCW120635K7FKEA	Vishay-Dale		
R18	1	200k	RES, 200 k, 1%, 0.1 W, AEC-Q200 Grade 0, 0603	0603	CRCW0603200KFKEA	Vishay-Dale		
R23	1	47.0k	RES, 47.0 k, 1%, 0.0625 W, 0402	0402	RC0402FR-0747KL	Yageo America		
S1	1		Switch, SPST-NO, 0.05 A, 12 VDC, SMT	3x2mm	TL3780AF330QG	E-Switch		
SH-J1, SH-J2, SH-J3, SH-J4, SH-J5, SH-J6, SH-J7, SH-J8	8	1x2	Shunt, 100mil, Flash Gold, Black	Closed Top 100mil Shunt	SPC02SYAN	Sullins Connector Solutions		
TP1, TP2	2		Test Point, Multipurpose, Red, TH	Red Multipurpose Testpoint	5010	Keystone		
TP3, TP10, TP11, TP12, TP13	5		Test Point, Compact, SMT	Testpoint_Keystone_Compact	5016	Keystone		
TP4, TP5, TP6, TP7, TP8	5		Test Point, Multipurpose, White, TH	White Multipurpose Testpoint	5012	Keystone		
TP9	1		Test Point, Multipurpose, Black, TH	Black Multipurpose Testpoint	5011	Keystone		
U1	1		7.5-100V Wide Vin, 100mA Constant On-Time Synchronous Buck Regulator, DDA0008B (SOIC-8)	DDA0008B	LM5019MRX/NOPB	Texas Instruments	LM5019MR/NOPB	Texas Instruments
U2, U4	2		2.5 kVrms, 25 Mbps, 4-Channel 3/1 Digital Isolator, DW0016B (SOIC-16)	DW0016B	ISO7241CDW	Texas Instruments		
U3	1		Single Buffer/Driver With Open-Drain Output, DCK0005A, LARGE T&R	DCK0005A	SN74LVC1G07DCKR	Texas Instruments		
C2, C5, C20	0	1uF	CAP, CERM, 1 uF, 10 V, +/- 10%, X7R, 0805	0805	0805ZC105KAT2A	AVX		
C19	0	0.1uF	CAP, CERM, 0.1 uF, 50 V, +/- 10%, X7R, 0603	0603	06035C104KAT2A	AVX		
FID1, FID2, FID3, FID4, FID5, FID6	0		Fiducial mark. There is nothing to buy or mount.	N/A	N/A	N/A		

Table 8. TPS23882EVM-008 Bill of Material

Designator	Quantity	Value	Description	PackageReference	PartNumber	Manufacturer	Alternate PartNumber	Alternate Manufacturer
!PCB	1		Printed Circuit Board		PSIL008	Any		
C1	1	0.1uF	CAP, CERM, 0.1 uF, 50 V, +/- 10%, X7R, 0603	0603	06035C104KAT2A	AVX		
C2, C3, C4, C5, C6, C7, C8, C9, C10	9	0.1uF	CAP, CERM, 0.1 uF, 100 V, +/- 10%, X7R, 0805	0805	C2012X7R2A104K125AA	TDK		
C11	1	1uF	CAP, CERM, 1 uF, 100 V, +/- 10%, X7R, 1206	1206	C3216X7R2A105K160AA	TDK		
C12	1	0.01uF	CAP, CERM, 0.01 uF, 16 V, +/- 10%, X7R, 0402	0402	520L103KT16T	AT Ceramics		
D1, D2, D3, D4, D5, D6, D7, D8	8	58V	Diode, TVS, Uni, 58 V, 93.6 Vc, SMB	SMB	SMBJ58A-13-F	Diodes Inc.		
J1, J2	2		Header, 100mil, 10x1, Gold, TH	10x1 Header	TSW-110-07-G-S	Samtec		
J3	1		Header, 100mil, 12x1, Gold, TH	12x1 Header	TSW-112-07-G-S	Samtec		
J4	1		Header, 100mil, 4x2, Gold, TH	4x2 Header	TSW-104-07-G-D	Samtec		
J5	1		Header, 100mil, 7x2, Gold, TH	7x2 Header	TSW-107-07-G-D	Samtec		
LBL1	1		Thermal Transfer Printable Labels, 0.650" W x 0.200" H - 10,000 per roll	PCB Label 0.650 x 0.200 inch	THT-14-423-10	Brady		
Q1, Q2, Q3, Q4, Q5, Q6, Q7, Q8	8	100V	MOSFET, N-CH, 100 V, 5 A, DNH0008A (VSONP-8)	DNH0008A	CSD19538Q3A	Texas Instruments		None
R1, R3, R5, R7, R10, R12, R14, R16	8	0.2	RES, 0.2, 1%, 0.333 W, 0805	0805	RL1220S-R20-F	Susumu Co Ltd		
R17	1	124k	RES, 124 k, 1%, 0.125 W, AEC-Q200 Grade 0, 0805	0805	CRCW0805124KFKEA	Vishay-Dale		
R18	1	61.9k	RES, 61.9 k, 1%, 0.125 W, AEC-Q200 Grade 0, 0805	0805	CRCW080561K9FKEA	Vishay-Dale		
SH-J1, SH-J2, SH-J3, SH-J4, SH-J5	5	1x2	Shunt, 100mil, Flash Gold, Black	Closed Top 100mil Shunt	SPC02SYAN	Sullins Connector Solutions		
TP1	1		Test Point, Multipurpose, Black, TH	Black Multipurpose Testpoint	5011	Keystone		
TP2, TP5, TP6	3		Test Point, Miniature, Red, TH	Red Miniature Testpoint	5000	Keystone		
TP3, TP4, TP7	3		Test Point, Miniature, White, TH	White Miniature Testpoint	5002	Keystone		
TP8	1		Test Point, Compact, SMT	Testpoint_Keystone_Compact	5016	Keystone		
U1	1		High-Power, 8-Channel, Power-Over-Ethernet PSE With 200-mO RSENSE, RTQ0056E (VQFN-56)	RTQ0056E	TPS23882RTQR	Texas Instruments	TPS23882RTQT	Texas Instruments
FID1, FID2, FID3, FID4, FID5, FID6	0		Fiducial mark. There is nothing to buy or mount.	N/A	N/A	N/A		
R2, R4, R6, R8, R9, R11, R13, R15	0	0.51	RES, 0.51, 1%, 0.25 W, 0805	0805	CRM0805-FX-R510ELF	Bourns		
R19	0	35.7k	RES, 35.7 k, 1%, 0.125 W, AEC-Q200 Grade 0, 0805	0805	ERJ-6ENF3572V	Panasonic		
R20	0	22.6k	RES, 22.6 k, 1%, 0.125 W, AEC-Q200 Grade 0, 0805	0805	ERJ-6ENF2262V	Panasonic		
R21	0	15.8k	RES, 15.8 k, 1%, 0.125 W, AEC-Q200 Grade 0, 0805	0805	ERJ-6ENF1582V	Panasonic		
R22	0	11.0k	RES, 11.0 k, 1%, 0.125 W, AEC-Q200 Grade 0, 0805	0805	ERJ-6ENF1102V	Panasonic		
R23	0	7.68k	RES, 7.68 k, 1%, 0.125 W, AEC-Q200 Grade 0, 0805	0805	ERJ-6ENF7681V	Panasonic		

STANDARD TERMS FOR EVALUATION MODULES

1. *Delivery:* TI delivers TI evaluation boards, kits, or modules, including any accompanying demonstration software, components, and/or documentation which may be provided together or separately (collectively, an "EVM" or "EVMs") to the User ("User") in accordance with the terms set forth herein. User's acceptance of the EVM is expressly subject to the following terms.
 - 1.1 EVMs are intended solely for product or software developers for use in a research and development setting to facilitate feasibility evaluation, experimentation, or scientific analysis of TI semiconductors products. EVMs have no direct function and are not finished products. EVMs shall not be directly or indirectly assembled as a part or subassembly in any finished product. For clarification, any software or software tools provided with the EVM ("Software") shall not be subject to the terms and conditions set forth herein but rather shall be subject to the applicable terms that accompany such Software
 - 1.2 EVMs are not intended for consumer or household use. EVMs may not be sold, sublicensed, leased, rented, loaned, assigned, or otherwise distributed for commercial purposes by Users, in whole or in part, or used in any finished product or production system.
2. *Limited Warranty and Related Remedies/Disclaimers:*
 - 2.1 These terms do not apply to Software. The warranty, if any, for Software is covered in the applicable Software License Agreement.
 - 2.2 TI warrants that the TI EVM will conform to TI's published specifications for ninety (90) days after the date TI delivers such EVM to User. Notwithstanding the foregoing, TI shall not be liable for a nonconforming EVM if (a) the nonconformity was caused by neglect, misuse or mistreatment by an entity other than TI, including improper installation or testing, or for any EVMs that have been altered or modified in any way by an entity other than TI, (b) the nonconformity resulted from User's design, specifications or instructions for such EVMs or improper system design, or (c) User has not paid on time. Testing and other quality control techniques are used to the extent TI deems necessary. TI does not test all parameters of each EVM. User's claims against TI under this Section 2 are void if User fails to notify TI of any apparent defects in the EVMs within ten (10) business days after delivery, or of any hidden defects with ten (10) business days after the defect has been detected.
 - 2.3 TI's sole liability shall be at its option to repair or replace EVMs that fail to conform to the warranty set forth above, or credit User's account for such EVM. TI's liability under this warranty shall be limited to EVMs that are returned during the warranty period to the address designated by TI and that are determined by TI not to conform to such warranty. If TI elects to repair or replace such EVM, TI shall have a reasonable time to repair such EVM or provide replacements. Repaired EVMs shall be warranted for the remainder of the original warranty period. Replaced EVMs shall be warranted for a new full ninety (90) day warranty period.

WARNING

Evaluation Kits are intended solely for use by technically qualified, professional electronics experts who are familiar with the dangers and application risks associated with handling electrical mechanical components, systems, and subsystems.

User shall operate the Evaluation Kit within TI's recommended guidelines and any applicable legal or environmental requirements as well as reasonable and customary safeguards. Failure to set up and/or operate the Evaluation Kit within TI's recommended guidelines may result in personal injury or death or property damage. Proper set up entails following TI's instructions for electrical ratings of interface circuits such as input, output and electrical loads.

NOTE:

EXPOSURE TO ELECTROSTATIC DISCHARGE (ESD) MAY CAUSE DEGRADATION OR FAILURE OF THE EVALUATION KIT; TI RECOMMENDS STORAGE OF THE EVALUATION KIT IN A PROTECTIVE ESD BAG.

3 Regulatory Notices:

3.1 United States

3.1.1 Notice applicable to EVMs not FCC-Approved:

FCC NOTICE: This kit is designed to allow product developers to evaluate electronic components, circuitry, or software associated with the kit to determine whether to incorporate such items in a finished product and software developers to write software applications for use with the end product. This kit is not a finished product and when assembled may not be resold or otherwise marketed unless all required FCC equipment authorizations are first obtained. Operation is subject to the condition that this product not cause harmful interference to licensed radio stations and that this product accept harmful interference. Unless the assembled kit is designed to operate under part 15, part 18 or part 95 of this chapter, the operator of the kit must operate under the authority of an FCC license holder or must secure an experimental authorization under part 5 of this chapter.

3.1.2 For EVMs annotated as FCC – FEDERAL COMMUNICATIONS COMMISSION Part 15 Compliant:

CAUTION

This device complies with part 15 of the FCC Rules. Operation is subject to the following two conditions: (1) This device may not cause harmful interference, and (2) this device must accept any interference received, including interference that may cause undesired operation.

Changes or modifications not expressly approved by the party responsible for compliance could void the user's authority to operate the equipment.

FCC Interference Statement for Class A EVM devices

NOTE: This equipment has been tested and found to comply with the limits for a Class A digital device, pursuant to part 15 of the FCC Rules. These limits are designed to provide reasonable protection against harmful interference when the equipment is operated in a commercial environment. This equipment generates, uses, and can radiate radio frequency energy and, if not installed and used in accordance with the instruction manual, may cause harmful interference to radio communications. Operation of this equipment in a residential area is likely to cause harmful interference in which case the user will be required to correct the interference at his own expense.

FCC Interference Statement for Class B EVM devices

NOTE: This equipment has been tested and found to comply with the limits for a Class B digital device, pursuant to part 15 of the FCC Rules. These limits are designed to provide reasonable protection against harmful interference in a residential installation. This equipment generates, uses and can radiate radio frequency energy and, if not installed and used in accordance with the instructions, may cause harmful interference to radio communications. However, there is no guarantee that interference will not occur in a particular installation. If this equipment does cause harmful interference to radio or television reception, which can be determined by turning the equipment off and on, the user is encouraged to try to correct the interference by one or more of the following measures:

- Reorient or relocate the receiving antenna.
- Increase the separation between the equipment and receiver.
- Connect the equipment into an outlet on a circuit different from that to which the receiver is connected.
- Consult the dealer or an experienced radio/TV technician for help.

3.2 Canada

3.2.1 For EVMs issued with an Industry Canada Certificate of Conformance to RSS-210 or RSS-247

Concerning EVMs Including Radio Transmitters:

This device complies with Industry Canada license-exempt RSSs. Operation is subject to the following two conditions:

(1) this device may not cause interference, and (2) this device must accept any interference, including interference that may cause undesired operation of the device.

Concernant les EVMs avec appareils radio:

Le présent appareil est conforme aux CNR d'Industrie Canada applicables aux appareils radio exempts de licence. L'exploitation est autorisée aux deux conditions suivantes: (1) l'appareil ne doit pas produire de brouillage, et (2) l'utilisateur de l'appareil doit accepter tout brouillage radioélectrique subi, même si le brouillage est susceptible d'en compromettre le fonctionnement.

Concerning EVMs Including Detachable Antennas:

Under Industry Canada regulations, this radio transmitter may only operate using an antenna of a type and maximum (or lesser) gain approved for the transmitter by Industry Canada. To reduce potential radio interference to other users, the antenna type and its gain should be so chosen that the equivalent isotropically radiated power (e.i.r.p.) is not more than that necessary for successful communication. This radio transmitter has been approved by Industry Canada to operate with the antenna types listed in the user guide with the maximum permissible gain and required antenna impedance for each antenna type indicated. Antenna types not included in this list, having a gain greater than the maximum gain indicated for that type, are strictly prohibited for use with this device.

Concernant les EVMs avec antennes détachables

Conformément à la réglementation d'Industrie Canada, le présent émetteur radio peut fonctionner avec une antenne d'un type et d'un gain maximal (ou inférieur) approuvé pour l'émetteur par Industrie Canada. Dans le but de réduire les risques de brouillage radioélectrique à l'intention des autres utilisateurs, il faut choisir le type d'antenne et son gain de sorte que la puissance isotrope rayonnée équivalente (p.i.r.e.) ne dépasse pas l'intensité nécessaire à l'établissement d'une communication satisfaisante. Le présent émetteur radio a été approuvé par Industrie Canada pour fonctionner avec les types d'antenne énumérés dans le manuel d'usage et ayant un gain admissible maximal et l'impédance requise pour chaque type d'antenne. Les types d'antenne non inclus dans cette liste, ou dont le gain est supérieur au gain maximal indiqué, sont strictement interdits pour l'exploitation de l'émetteur.

3.3 Japan

3.3.1 *Notice for EVMs delivered in Japan:* Please see http://www.tij.co.jp/lstds/ti_ja/general/eStore/notice_01.page 日本国内に輸入される評価用キット、ボードについては、次のところをご覧ください。
http://www.tij.co.jp/lstds/ti_ja/general/eStore/notice_01.page

3.3.2 *Notice for Users of EVMs Considered "Radio Frequency Products" in Japan:* EVMs entering Japan may not be certified by TI as conforming to Technical Regulations of Radio Law of Japan.

If User uses EVMs in Japan, not certified to Technical Regulations of Radio Law of Japan, User is required to follow the instructions set forth by Radio Law of Japan, which includes, but is not limited to, the instructions below with respect to EVMs (which for the avoidance of doubt are stated strictly for convenience and should be verified by User):

1. Use EVMs in a shielded room or any other test facility as defined in the notification #173 issued by Ministry of Internal Affairs and Communications on March 28, 2006, based on Sub-section 1.1 of Article 6 of the Ministry's Rule for Enforcement of Radio Law of Japan,
2. Use EVMs only after User obtains the license of Test Radio Station as provided in Radio Law of Japan with respect to EVMs, or
3. Use of EVMs only after User obtains the Technical Regulations Conformity Certification as provided in Radio Law of Japan with respect to EVMs. Also, do not transfer EVMs, unless User gives the same notice above to the transferee. Please note that if User does not follow the instructions above, User will be subject to penalties of Radio Law of Japan.

【無線電波を送信する製品の開発キットをお使いになる際の注意事項】 開発キットの中には技術基準適合証明を受けていないものがあります。技術適合証明を受けていないものご使用に際しては、電波法遵守のため、以下のいずれかの措置を取っていただく必要がありますのでご注意ください。

1. 電波法施行規則第6条第1項第1号に基づく平成18年3月28日総務省告示第173号で定められた電波暗室等の試験設備でご使用いただく。
2. 実験局の免許を取得後ご使用いただく。
3. 技術基準適合証明を取得後ご使用いただく。

なお、本製品は、上記の「ご使用にあたっての注意」を譲渡先、移転先に通知しない限り、譲渡、移転できないものとします。

上記を遵守頂けない場合は、電波法の罰則が適用される可能性があることをご留意ください。日本テキサス・インスツルメンツ株式会社
東京都新宿区西新宿 6 丁目 2 4 番 1 号
西新宿三井ビル

3.3.3 *Notice for EVMs for Power Line Communication:* Please see http://www.tij.co.jp/lstds/ti_ja/general/eStore/notice_02.page
電力線搬送波通信についての開発キットをお使いになる際の注意事項については、次のところをご覧ください。http://www.tij.co.jp/lstds/ti_ja/general/eStore/notice_02.page

3.4 European Union

3.4.1 *For EVMs subject to EU Directive 2014/30/EU (Electromagnetic Compatibility Directive):*

This is a class A product intended for use in environments other than domestic environments that are connected to a low-voltage power-supply network that supplies buildings used for domestic purposes. In a domestic environment this product may cause radio interference in which case the user may be required to take adequate measures.

4 *EVM Use Restrictions and Warnings:*

4.1 EVMS ARE NOT FOR USE IN FUNCTIONAL SAFETY AND/OR SAFETY CRITICAL EVALUATIONS, INCLUDING BUT NOT LIMITED TO EVALUATIONS OF LIFE SUPPORT APPLICATIONS.

4.2 User must read and apply the user guide and other available documentation provided by TI regarding the EVM prior to handling or using the EVM, including without limitation any warning or restriction notices. The notices contain important safety information related to, for example, temperatures and voltages.

4.3 *Safety-Related Warnings and Restrictions:*

4.3.1 User shall operate the EVM within TI's recommended specifications and environmental considerations stated in the user guide, other available documentation provided by TI, and any other applicable requirements and employ reasonable and customary safeguards. Exceeding the specified performance ratings and specifications (including but not limited to input and output voltage, current, power, and environmental ranges) for the EVM may cause personal injury or death, or property damage. If there are questions concerning performance ratings and specifications, User should contact a TI field representative prior to connecting interface electronics including input power and intended loads. Any loads applied outside of the specified output range may also result in unintended and/or inaccurate operation and/or possible permanent damage to the EVM and/or interface electronics. Please consult the EVM user guide prior to connecting any load to the EVM output. If there is uncertainty as to the load specification, please contact a TI field representative. During normal operation, even with the inputs and outputs kept within the specified allowable ranges, some circuit components may have elevated case temperatures. These components include but are not limited to linear regulators, switching transistors, pass transistors, current sense resistors, and heat sinks, which can be identified using the information in the associated documentation. When working with the EVM, please be aware that the EVM may become very warm.

4.3.2 EVMs are intended solely for use by technically qualified, professional electronics experts who are familiar with the dangers and application risks associated with handling electrical mechanical components, systems, and subsystems. User assumes all responsibility and liability for proper and safe handling and use of the EVM by User or its employees, affiliates, contractors or designees. User assumes all responsibility and liability to ensure that any interfaces (electronic and/or mechanical) between the EVM and any human body are designed with suitable isolation and means to safely limit accessible leakage currents to minimize the risk of electrical shock hazard. User assumes all responsibility and liability for any improper or unsafe handling or use of the EVM by User or its employees, affiliates, contractors or designees.

4.4 User assumes all responsibility and liability to determine whether the EVM is subject to any applicable international, federal, state, or local laws and regulations related to User's handling and use of the EVM and, if applicable, User assumes all responsibility and liability for compliance in all respects with such laws and regulations. User assumes all responsibility and liability for proper disposal and recycling of the EVM consistent with all applicable international, federal, state, and local requirements.

5. *Accuracy of Information:* To the extent TI provides information on the availability and function of EVMs, TI attempts to be as accurate as possible. However, TI does not warrant the accuracy of EVM descriptions, EVM availability or other information on its websites as accurate, complete, reliable, current, or error-free.

6. *Disclaimers:*

6.1 EXCEPT AS SET FORTH ABOVE, EVMS AND ANY MATERIALS PROVIDED WITH THE EVM (INCLUDING, BUT NOT LIMITED TO, REFERENCE DESIGNS AND THE DESIGN OF THE EVM ITSELF) ARE PROVIDED "AS IS" AND "WITH ALL FAULTS." TI DISCLAIMS ALL OTHER WARRANTIES, EXPRESS OR IMPLIED, REGARDING SUCH ITEMS, INCLUDING BUT NOT LIMITED TO ANY EPIDEMIC FAILURE WARRANTY OR IMPLIED WARRANTIES OF MERCHANTABILITY OR FITNESS FOR A PARTICULAR PURPOSE OR NON-INFRINGEMENT OF ANY THIRD PARTY PATENTS, COPYRIGHTS, TRADE SECRETS OR OTHER INTELLECTUAL PROPERTY RIGHTS.

6.2 EXCEPT FOR THE LIMITED RIGHT TO USE THE EVM SET FORTH HEREIN, NOTHING IN THESE TERMS SHALL BE CONSTRUED AS GRANTING OR CONFERRING ANY RIGHTS BY LICENSE, PATENT, OR ANY OTHER INDUSTRIAL OR INTELLECTUAL PROPERTY RIGHT OF TI, ITS SUPPLIERS/LICENSORS OR ANY OTHER THIRD PARTY, TO USE THE EVM IN ANY FINISHED END-USER OR READY-TO-USE FINAL PRODUCT, OR FOR ANY INVENTION, DISCOVERY OR IMPROVEMENT, REGARDLESS OF WHEN MADE, CONCEIVED OR ACQUIRED.

7. *USER'S INDEMNITY OBLIGATIONS AND REPRESENTATIONS.* USER WILL DEFEND, INDEMNIFY AND HOLD TI, ITS LICENSORS AND THEIR REPRESENTATIVES HARMLESS FROM AND AGAINST ANY AND ALL CLAIMS, DAMAGES, LOSSES, EXPENSES, COSTS AND LIABILITIES (COLLECTIVELY, "CLAIMS") ARISING OUT OF OR IN CONNECTION WITH ANY HANDLING OR USE OF THE EVM THAT IS NOT IN ACCORDANCE WITH THESE TERMS. THIS OBLIGATION SHALL APPLY WHETHER CLAIMS ARISE UNDER STATUTE, REGULATION, OR THE LAW OF TORT, CONTRACT OR ANY OTHER LEGAL THEORY, AND EVEN IF THE EVM FAILS TO PERFORM AS DESCRIBED OR EXPECTED.

8. *Limitations on Damages and Liability:*

8.1 *General Limitations.* IN NO EVENT SHALL TI BE LIABLE FOR ANY SPECIAL, COLLATERAL, INDIRECT, PUNITIVE, INCIDENTAL, CONSEQUENTIAL, OR EXEMPLARY DAMAGES IN CONNECTION WITH OR ARISING OUT OF THESE TERMS OR THE USE OF THE EVMS , REGARDLESS OF WHETHER TI HAS BEEN ADVISED OF THE POSSIBILITY OF SUCH DAMAGES. EXCLUDED DAMAGES INCLUDE, BUT ARE NOT LIMITED TO, COST OF REMOVAL OR REINSTALLATION, ANCILLARY COSTS TO THE PROCUREMENT OF SUBSTITUTE GOODS OR SERVICES, RETESTING, OUTSIDE COMPUTER TIME, LABOR COSTS, LOSS OF GOODWILL, LOSS OF PROFITS, LOSS OF SAVINGS, LOSS OF USE, LOSS OF DATA, OR BUSINESS INTERRUPTION. NO CLAIM, SUIT OR ACTION SHALL BE BROUGHT AGAINST TI MORE THAN TWELVE (12) MONTHS AFTER THE EVENT THAT GAVE RISE TO THE CAUSE OF ACTION HAS OCCURRED.

8.2 *Specific Limitations.* IN NO EVENT SHALL TI'S AGGREGATE LIABILITY FROM ANY USE OF AN EVM PROVIDED HEREUNDER, INCLUDING FROM ANY WARRANTY, INDEMNITY OR OTHER OBLIGATION ARISING OUT OF OR IN CONNECTION WITH THESE TERMS, , EXCEED THE TOTAL AMOUNT PAID TO TI BY USER FOR THE PARTICULAR EVM(S) AT ISSUE DURING THE PRIOR TWELVE (12) MONTHS WITH RESPECT TO WHICH LOSSES OR DAMAGES ARE CLAIMED. THE EXISTENCE OF MORE THAN ONE CLAIM SHALL NOT ENLARGE OR EXTEND THIS LIMIT.

9. *Return Policy.* Except as otherwise provided, TI does not offer any refunds, returns, or exchanges. Furthermore, no return of EVM(s) will be accepted if the package has been opened and no return of the EVM(s) will be accepted if they are damaged or otherwise not in a resalable condition. If User feels it has been incorrectly charged for the EVM(s) it ordered or that delivery violates the applicable order, User should contact TI. All refunds will be made in full within thirty (30) working days from the return of the components(s), excluding any postage or packaging costs.

10. *Governing Law:* These terms and conditions shall be governed by and interpreted in accordance with the laws of the State of Texas, without reference to conflict-of-laws principles. User agrees that non-exclusive jurisdiction for any dispute arising out of or relating to these terms and conditions lies within courts located in the State of Texas and consents to venue in Dallas County, Texas. Notwithstanding the foregoing, any judgment may be enforced in any United States or foreign court, and TI may seek injunctive relief in any United States or foreign court.

Mailing Address: Texas Instruments, Post Office Box 655303, Dallas, Texas 75265
Copyright © 2019, Texas Instruments Incorporated

IMPORTANT NOTICE AND DISCLAIMER

TI PROVIDES TECHNICAL AND RELIABILITY DATA (INCLUDING DATASHEETS), DESIGN RESOURCES (INCLUDING REFERENCE DESIGNS), APPLICATION OR OTHER DESIGN ADVICE, WEB TOOLS, SAFETY INFORMATION, AND OTHER RESOURCES "AS IS" AND WITH ALL FAULTS, AND DISCLAIMS ALL WARRANTIES, EXPRESS AND IMPLIED, INCLUDING WITHOUT LIMITATION ANY IMPLIED WARRANTIES OF MERCHANTABILITY, FITNESS FOR A PARTICULAR PURPOSE OR NON-INFRINGEMENT OF THIRD PARTY INTELLECTUAL PROPERTY RIGHTS.

These resources are intended for skilled developers designing with TI products. You are solely responsible for (1) selecting the appropriate TI products for your application, (2) designing, validating and testing your application, and (3) ensuring your application meets applicable standards, and any other safety, security, or other requirements. These resources are subject to change without notice. TI grants you permission to use these resources only for development of an application that uses the TI products described in the resource. Other reproduction and display of these resources is prohibited. No license is granted to any other TI intellectual property right or to any third party intellectual property right. TI disclaims responsibility for, and you will fully indemnify TI and its representatives against, any claims, damages, costs, losses, and liabilities arising out of your use of these resources.

TI's products are provided subject to TI's Terms of Sale (www.ti.com/legal/termsofsale.html) or other applicable terms available either on ti.com or provided in conjunction with such TI products. TI's provision of these resources does not expand or otherwise alter TI's applicable warranties or warranty disclaimers for TI products.

Mailing Address: Texas Instruments, Post Office Box 655303, Dallas, Texas 75265
Copyright © 2019, Texas Instruments Incorporated