

## Low Power, Precision Zero Crossing Detector

**MAX22707**

### Product Highlights

- Precision Zero Crossing Detection
  - Integrated Zero Crossing Detection with  $\pm 1\%$  Accuracy
  - High Frequency Noise Filter
  - 4<sup>th</sup> Order Low-Pass Filter (LPF)
  - 4<sup>th</sup> Order Band-Pass Filter (BPF)
- Configurability for Ease of Use
  - User Selectable Filter Configuration (LPF or BPF)
  - Selectable Input Frequency
  - Power Saving Stand-By Mode
  - Programmable DC Averaging Timer
- Saves PCB Space and Bill of Materials (BOM) Cost
  - No External Precision Filter Capacitor Required
  - 10-Pin  $\mu$ MAX package 3mm x 3mm

- AC Phase Detection
 

The integrated solution with user selectable filter configuration improves zero-crossing detection with  $\pm 1\%$  accuracy. The available filter types are the fourth order BPF and LPF. The DC averaging filter capacitor function is used for the LPF.
- Flexible Zero Crossing Detection
 

The MAX22707 supports two basic input frequencies which depend on the filter type. If the band-pass is selected, the frequency selection mode control pin (MC) is used to choose between 50Hz and 60Hz. If the low-pass is selected, the same pin is used to choose between 50/60Hz and 100/120Hz signal band. To select between sine and rectified inputs, the rectified select pin (RS) is used.

For more product highlights, see [Detailed Description](#).

### Key Applications

- Industrial Lighting Dimming
 

The integrated filters eliminate the flicker and provide up to 75% reduction in PCB footprint compared to a discrete solution requiring multiple amplifiers, comparators, and precision filter capacitors and resistors. The MAX22707 features a low-power, precision analog filter based on the switched-capacitor technology designed for precision filtering of AC input noise. The device requires only a simple external input network preceding the AC inputs and no additional external components for the filters. The MAX22707 is rated for the operation at ambient temperatures of  $-40^{\circ}\text{C}$  to  $+125^{\circ}\text{C}$ .

### Pin Description

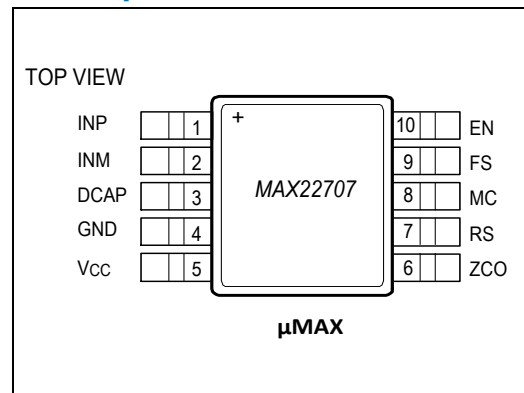

[Ordering Information](#) appears at end of data sheet.

### Simplified Application Diagram

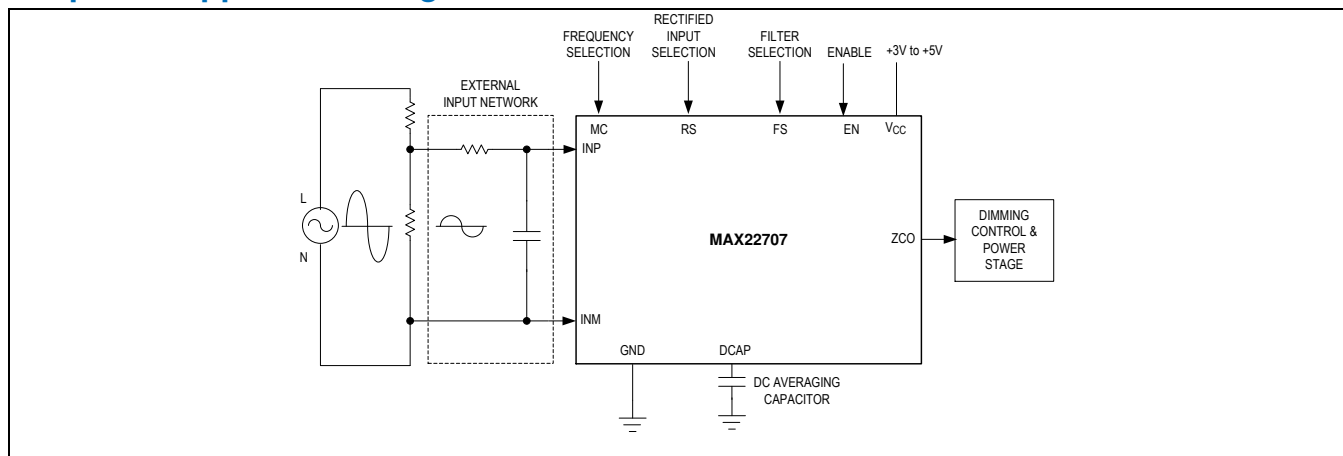

## Absolute Maximum Ratings

|  |  |
|--|--|
| $V_{CC}$ to GND .....                                      | -0.3V to +6V                                 |
| ZCO, DCAP to GND.....                                      | -0.3V to +6V                                 |
| EN, RS, MC, FS to GND.....                                 | -0.3V to Min(+6V, ( $V_{CC} + 0.3V$ ))V      |
| INP, INM to GND .....                                      | -( $V_{CC} + 0.3$ ) V to ( $V_{CC} + 0.3$ )V |
| Short Circuit Duration (ZCO to GND) .....                  | Continuous                                   |
| Continuous Current (INP, INM to GND) .....                 | 20mA   |
| Continuous Power Dissipation ( $T_A = +70^\circ\text{C}$ ) |  |

|   |   |
|---|---|
| 10-pin $\mu\text{MAX}$ (derate 8.8mW/ $^\circ\text{C}$ above $+70^\circ\text{C}$ )..... | 707.3mW                                     |
| Temperature Ratings   |   |
| Operating Temperature Range.....  | $-40^\circ\text{C}$ to $+125^\circ\text{C}$ |
| Maximum Junction Temperature .....  | $+150^\circ\text{C}$                        |
| Storage Temperature Range .....   | $-65^\circ\text{C}$ to $+150^\circ\text{C}$ |
| Lead Temperature (soldering, 1s).....   | $+300^\circ\text{C}$                        |
| Soldering Temperature (reflow).....   | $+260^\circ\text{C}$                        |

Stresses beyond those listed under "Absolute Maximum Ratings" may cause permanent damage to the device. These are stress ratings only, and functional operation of the device at these or any other conditions beyond those indicated in the operational sections of the specifications is not implied. Exposure to absolute maximum rating conditions for extended periods may affect device reliability.

## Package Information

### 10- $\mu\text{MAX}$

|   |                         |
|---|-------------------------|
| Package Code  | U10+6C                  |
| Outline Number  | <a href="#">21-0061</a> |
| Land Pattern Number                                   | <a href="#">90-0330</a> |
| <b>Thermal Resistance, Single Layer Board:</b>        |                         |
| Junction-to-Ambient ( $\theta_{JA}$ )                 | 180                     |
| Junction-to-Case Thermal Resistance ( $\theta_{JC}$ ) | 42                      |
| <b>Thermal Resistance, Four Layer Board:</b>          |                         |
| Junction-to-Ambient ( $\theta_{JA}$ )                 | 113.1                   |
| Junction-to-Case Thermal Resistance ( $\theta_{JC}$ ) | 42                      |

## Electrical Characteristics

( $V_{CC} - V_{GND} = 3.0\text{V}$  to  $5.5\text{V}$ ,  $T_A = -40^\circ\text{C}$  to  $+125^\circ\text{C}$ , Typical values are at  $V_{CC} = 5.0\text{V}$  and  $T_A = +25^\circ\text{C}$ , unless otherwise noted. ([Note 1](#)))

| PARAMETER  | SYMBOL      | CONDITIONS             | MIN                 | TYP | MAX | UNITS         |
|--|-------------|------------------------|---------------------|-----|-----|---------------|
| <b>POWER (<math>V_{CC}</math>, GND)</b>              |             |                        |                     |     |     |               |
| Positive Supply Voltage                              | $V_{CC}$    |                        | 3.0                 | 5.0 | 5.5 | V             |
| Positive Supply Current                              | $I_{CC}$    | EN = $V_{CC}$          |                     | 0.7 | 1.0 | mA            |
|  |             | EN = GND               |                     |     | 2.0 | $\mu\text{A}$ |
| Undervoltage-Lockout Threshold                       | $V_{UVLO}$  | $V_{CC}$ rising        | 1.7                 | 2.2 | 2.6 | V             |
| Undervoltage-Lockout Threshold Hysteresis            | $V_{UVHYS}$ |                        |                     | 50  |     | mV            |
| <b>DIGITAL LOGIC INTERFACE (MC, FS, RS, EN, ZCO)</b> |             |                        |                     |     |     |               |
| Input Voltage High                                   | $V_{IH}$    |                        | $0.7 \times V_{CC}$ |     |     | V             |
| Input Voltage Low                                    | $V_{IL}$    |                        | $0.3 \times V_{CC}$ |     |     | V             |
| Input Hysteresis                                     | $V_{HYS}$   | $V_{CC} = 3\text{V}$   | 300                 |     |     | mV            |
|  |             | $V_{CC} = 5.5\text{V}$ | 550                 |     |     |               |
| Input leakage Current                                | $I_{LK}$    |                        | -1                  |     | +1  | $\mu\text{A}$ |

( $V_{CC} - V_{GND} = 3.0V$  to  $5.5V$ ,  $T_A = -40^{\circ}C$  to  $+125^{\circ}C$ , Typical values are at  $V_{CC} = 5.0V$  and  $T_A = +25^{\circ}C$ , unless otherwise noted. ([Note 1](#)))

| PARAMETER   | SYMBOL                     | CONDITIONS   |           | MIN  | TYP   | MAX  | UNITS   |
|---|----------------------------|--|-----------|------|-------|------|---------|
| Input Capacitance   | $C_{IN}$                   |  |           |      | 2     |      | pF      |
| Output Logic High Leakage Current   | $I_{OH\_LK}$               | ZCO, $V_{ZCO} = 5.5V$  |           |      |       | +1   | $\mu A$ |
| Output Voltage Low  | $V_{OL}$                   | ZCO, $I_{OUT} = 4mA$   |           |      |       | 0.4  | V       |
| <b>ANALOG SIGNAL INTERFACE (INP, INM)</b>   |                            |  |           |      |       |      |         |
| Peak to peak Differential Voltage $ V_{INP} - V_{INM} $ ( <a href="#">Note 2</a> , <a href="#">Note 3</a> ) | $V_{DF\_PK}$               | All input configurations. See the <a href="#">Input Types: Bipolar and Unipolar</a> .  |           | 0.8  |       | 2.5  | V       |
| Differential Input common-mode voltage  | $V_{DF\_CM}$               | SE or DF Input   | Type 1    |      | 0     |      | V       |
|   |                            | DF Input   | Type 2    |      | 0.625 |      |         |
|   |                            | SE Input   | Type 2    |      | 1.25  |      |         |
| INM Voltage   | $V_{INM}$                  | SE Input   | Type 3, 4 |      | 0     |      | V       |
| <b>FILTER CHARACTERISTICS, FS = 0 (LOW PASS FILTER)</b>   |                            |  |           |      |       |      |         |
| Upper Passband Frequency  | $f_{C\_LPF\_PASS\_60}$     | MC = '0', -3dB   |           |      | 56    |      | Hz      |
|   | $f_{C\_LPF\_STOP\_60}$     | MC = '0', -25dB  |           |      | 168   |      |         |
|   | $f_{C\_LPF\_PASS\_120}$    | MC = '1', -3dB   |           |      | 112   |      |         |
|   | $f_{C\_LPF\_STOP\_120}$    | MC = '1', -25dB  |           |      | 336   |      |         |
| Slope in Transition   |                            | Between passband edge and stopband edge  |           |      | -80   |      | dB/dec  |
| <b>FILTER CHARACTERISTICS, FS = 1 (BAND PASS FILTER)</b>  |                            |  |           |      |       |      |         |
| Upper Passband Frequency  | $f_{C\_BPF\_PASS\_UP\_50}$ | Mode = '0', -3dB   |           |      | 86    |      | Hz      |
| Lower Passband Frequency  | $f_{C\_BPF\_PASS\_LO\_50}$ | Mode = '0', -3dB   |           |      | 27    |      | Hz      |
| Upper Passband Frequency  | $f_{C\_BPF\_PASS\_UP\_60}$ | Mode = '1', -3dB   |           |      | 96    |      | Hz      |
| Lower Passband Frequency  | $f_{C\_BPF\_PASS\_LO\_60}$ | Mode = '1', -3dB   |           |      | 37    |      | Hz      |
| Slope in Transition   |                            | Between passband edge and stopband edge  |           |      | -40   |      | dB/dec  |
| <b>ZERO CROSSING DETECTION, FS=0 (LOW PASS FILTER)</b>  |                            |  |           |      |       |      |         |
| Zero Crossing Time Delay ( <a href="#">Note 4</a> )   | $t_{D\_LPF\_ZCR\_60}$      | FS = MC = RS = '0', Total Time Delay with 60Hz input, DCAP = 220nF; $T_A = 0^{\circ}C$ to $+85^{\circ}C$ . See the <a href="#">Input Types: Bipolar and Unipolar</a> .       |           | 6.6  | 7.7   | 9.2  | msec    |
| Zero Crossing Time Delay ( <a href="#">Note 4</a> )   | $t_{D\_FW\_ZCR\_120}$      | FS = '0', MC = RS = '1', Total Time Delay with 120Hz input, DCAP = 220nF; $T_A = 0^{\circ}C$ to $+85^{\circ}C$ . See the <a href="#">Input Types: Bipolar and Unipolar</a> . |           | -4.5 | -3.7  | -2.8 | msec    |
| Zero Crossing Time Delay ( <a href="#">Note 4</a> )   | $t_{D\_HW\_ZCR\_60}$       | FS = MC = '0', RS = '1', Total Time Delay with 60Hz input, DCAP = 220nF; $T_A = 0^{\circ}C$ to $+85^{\circ}C$ . See the <a href="#">Input Types: Bipolar and Unipolar</a> .  |           | 5.3  | 6.2   | 7.5  | msec    |

( $V_{CC} - V_{GND} = 3.0V$  to  $5.5V$ ,  $T_A = -40^{\circ}C$  to  $+125^{\circ}C$ , Typical values are at  $V_{CC} = 5.0V$  and  $T_A = +25^{\circ}C$ , unless otherwise noted. ([Note 1](#)))

| PARAMETER   | SYMBOL                       | CONDITIONS   | MIN  | TYP        | MAX | UNITS     |
|---|------------------------------|--|------|------------|-----|-----------|
| Zero Crossing Time Delay Repeatability ( <a href="#">Note 4</a> ), ( <a href="#">Note 5</a> ) | $\Delta t_{D\_LPF\_ZCR\_60}$ | FS = MC = RS = '0', Total Time Delay Variation with 60Hz input, DCAP = 220nF; $T_A = 0^{\circ}C$ to $+85^{\circ}C$                                       | -16  |            | +16 | $\mu sec$ |
| Zero Crossing Time Delay Repeatability ( <a href="#">Note 5</a> )                             | $\Delta t_{D\_FW\_ZCR\_120}$ | FS = '0', MC = RS = '1', Total Time Delay Variation with 120Hz input, DCAP = 220nF; $T_A = 0^{\circ}C$ to $+85^{\circ}C$                                 | -20  |            | +20 | $\mu sec$ |
| Zero Crossing Time Delay Repeatability ( <a href="#">Note 4</a> ), ( <a href="#">Note 5</a> ) | $\Delta t_{D\_HW\_ZCR\_60}$  | FS = MC = '0', RS = '1' Total Time Delay Variation with 60Hz input, DCAP = 220nF; $T_A = 0^{\circ}C$ to $+85^{\circ}C$                                   | -16  |            | +16 | $\mu sec$ |
| Zero Crossing Comparator Reference  |                              | FS = '0'   |      | $V_{DCAP}$ |     | V         |
| <b>ZERO CROSSING DETECTION, FS=1 (BAND PASS FILTER)</b>                                       |                              |  |      |            |     |           |
| Zero Crossing Time Delay ( <a href="#">Note 4</a> )   | $t_{D\_BPF\_ZCR\_50}$        | FS = '1', MC = '0', Total Time Delay with 50Hz input; $T_A = 0^{\circ}C$ to $+85^{\circ}C$ . See the <a href="#">Input Types: Bipolar and Unipolar</a> . | -200 | 0          | 200 | $\mu sec$ |
|   | $t_{D\_BPF\_ZCR\_60}$        | FS = '1', MC = '1', Total Time Delay with 60Hz input; $T_A = 0^{\circ}C$ to $+85^{\circ}C$ . See the <a href="#">Input Types: Bipolar and Unipolar</a> . | -200 | 0          | 200 |           |
| Zero Crossing Time Delay Repeatability ( <a href="#">Note 4</a> ), ( <a href="#">Note 5</a> ) | $\Delta t_{D\_BPF\_ZCR}$     | FS = '1', Total Time Delay Variation with 50Hz or 60Hz input   | -21  |            | +21 | $\mu sec$ |
| ZC Comparator Reference   |                              | FS = '1'   |      | INM        |     |           |
| <b>PROTECTION</b>   |                              |  |      |            |     |           |
| ESD Protection (All Pins to GND)  |                              | Human Body Model   |      | $\pm 2$    |     | kV        |

**Note 1:** All units are production tested at  $T_A = +25^{\circ}C$ . Specifications over temperature are guaranteed by design.

**Note 2:** Differential input is between INP and INM.

**Note 3:** Input voltage is signal without noise.

**Note 4:** Measurement performed with noise ( $V_{NOISE} = V_{IN\_RMS}/17$  and  $f_{NOISE} = 4 \times f_{SIG}$ ) added to input signal.  $V_{IN\_RMS}$  is the RMS voltage of the input signal and  $f_{IN}$  is the input frequency (e.g. 50Hz, 60Hz). For Type 1, 2, and 4 inputs,  $f_{SIG} = f_{IN}$  while for Type 3 inputs,  $f_{SIG} = 2 \times f_{IN}$ . Input frequency must vary less than 1% of nominal.

**Note 5:** Repeatability refers to cycle-to-cycle variation of the delay for a single part and applies for a single set of conditions (i.e., fixed input frequency and fixed input amplitude).

Typical Operating Characteristics

( $V_{CC}$ ,  $V_{GND}$  = 3.0V to 5.5V,  $T_A$  = 25°C, unless otherwise noted.)

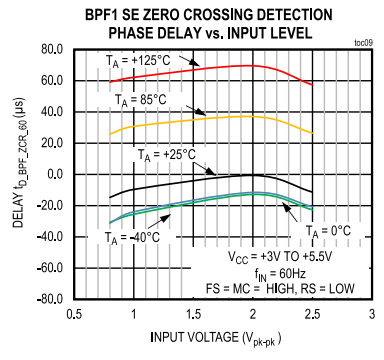
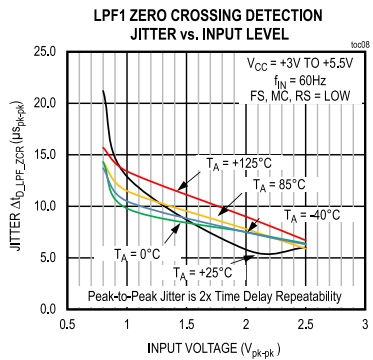
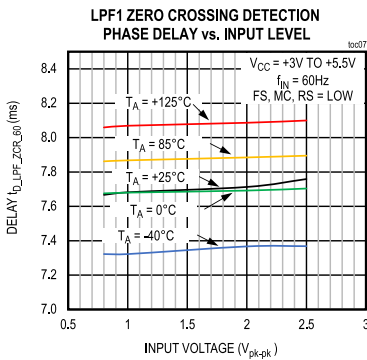
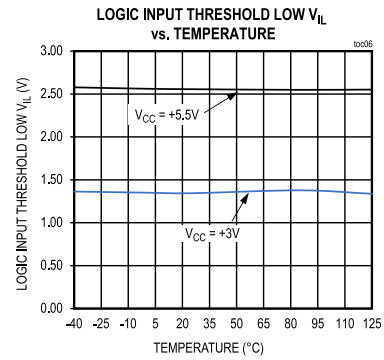
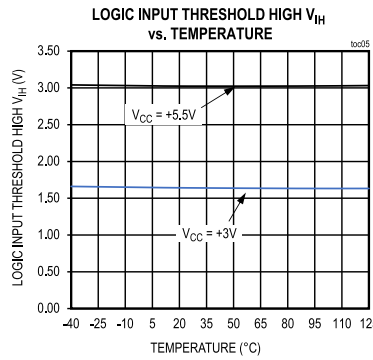
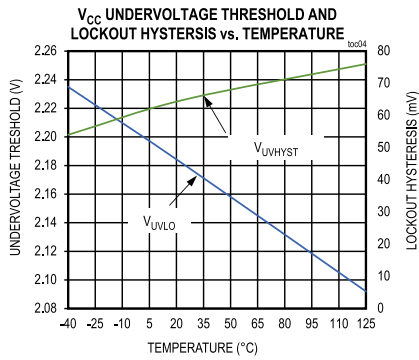
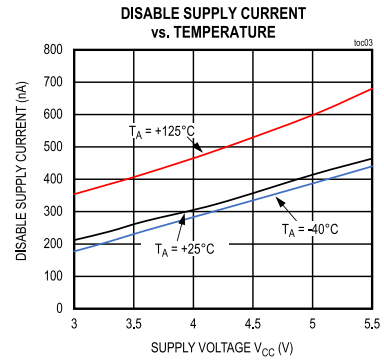
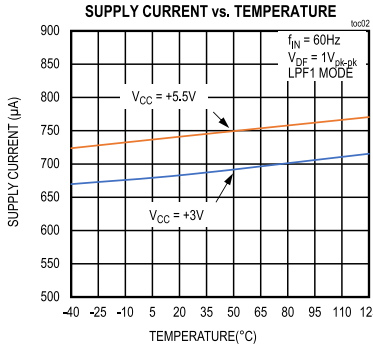
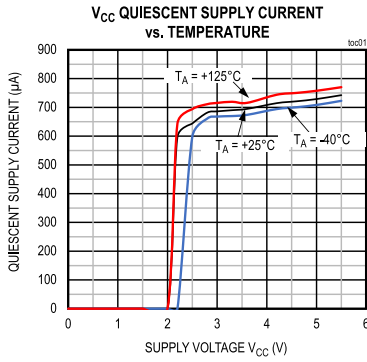

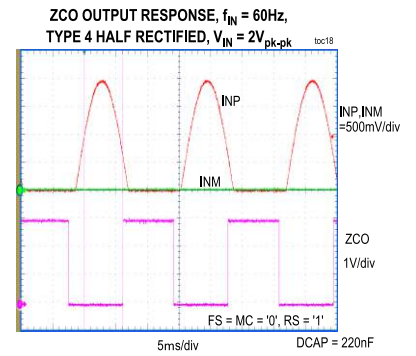
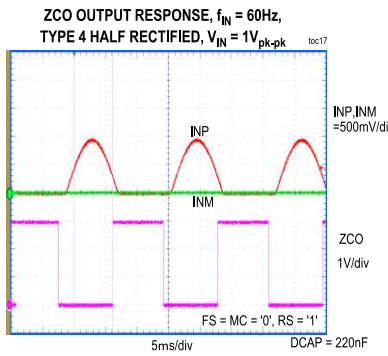
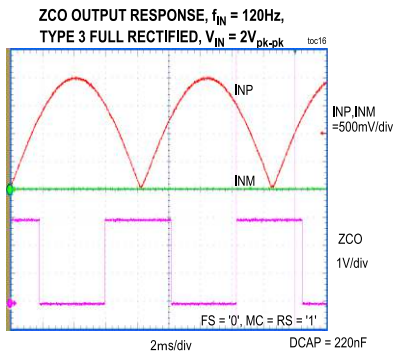
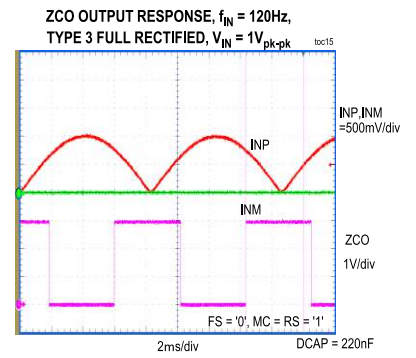
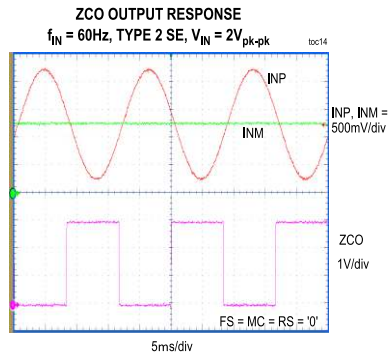
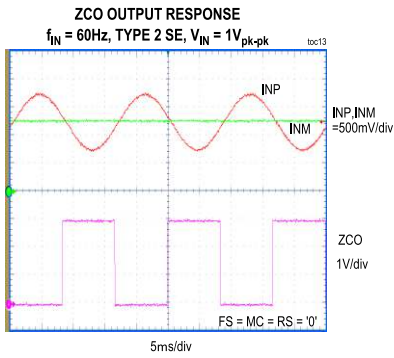
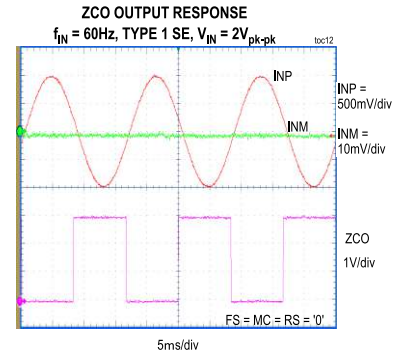
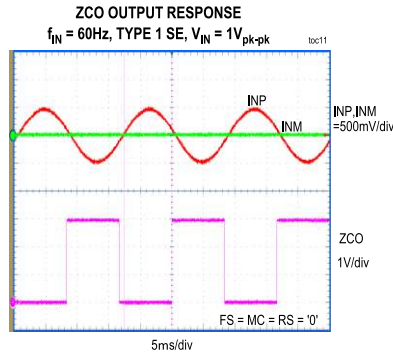
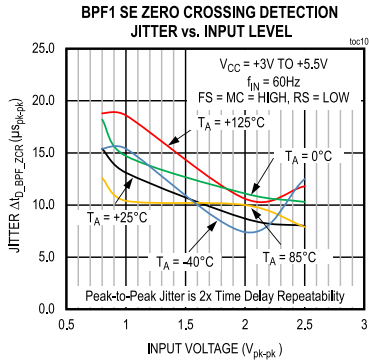

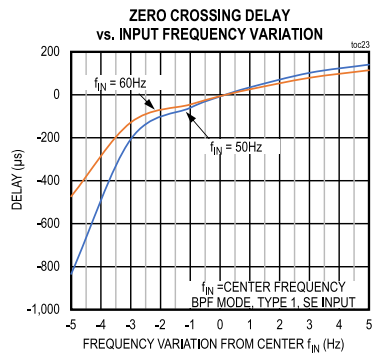
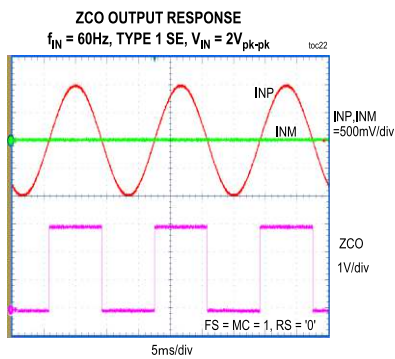
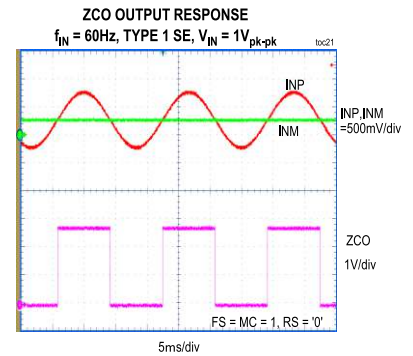
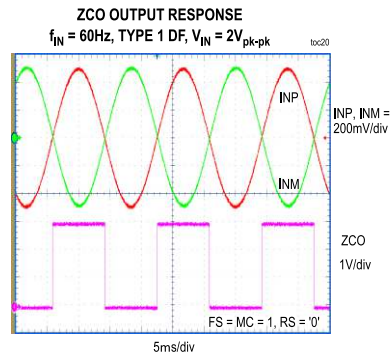
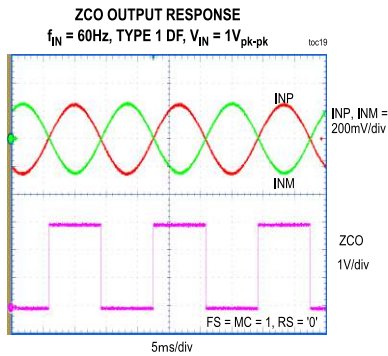

### Pin Configurations

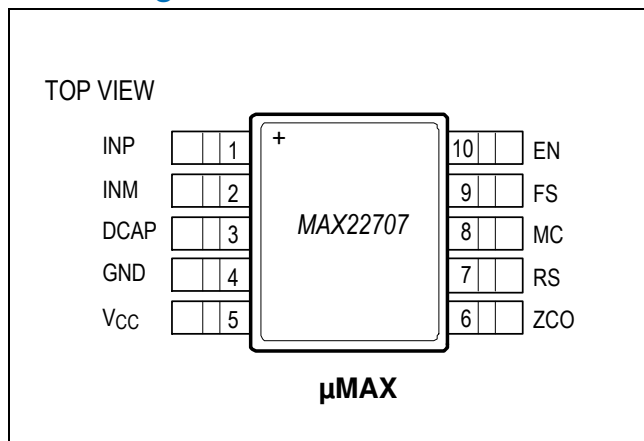

### Pin Descriptions

| PIN | NAME | FUNCTION  | Type          |
|-----|------|---|---------------|
| 1   | INP  | Input Positive AC Voltage (Line)  | Analog Input  |
| 2   | INM  | Input Negative AC Voltage (Neutral). Connect based on input configuration.  | Analog Input  |
| 3   | DCAP | DC averaging capacitor for LPF mode. Connect a 220nF capacitor to ground. When using BPF mode connect DCAP to ground. | Analog Output |
| 4   | GND  | Ground return.  | Supply        |



|    |     |   |                |
|----|-----|---|----------------|
| 5  | VCC | Positive Supply, $V_{CC} = 3.0V$ to $5.5V$ . Bypass $V_{CC}$ to GND with a $0.1\mu F$ capacitor   | Supply         |
| 6  | ZCO | Zero Crossing Open-Drain Output   | Digital Output |
| 7  | RS  | Rectified Input Selection. Set to 0 for sine wave input or set to 1 for rectified input.  | Digital Input  |
| 8  | MC  | Mode Control.<br>When $FS = 0$ (LPF): Set to 0 for 50/60Hz or Set to 1 for 100/120Hz.<br>When $FS = 1$ (BPF): Set to 0 for 50Hz or set to 1 for 60Hz. | Digital Input  |
| 9  | FS  | Filter Selection. Set to 0 for Low Pass Filter (LPF) or Set to 1 for Band Pass Filter (BPF).  | Digital Input  |
| 10 | EN  | Set to 1 to Enable. Set to 0 to power down.   | Digital Input  |

Functional Block Diagram

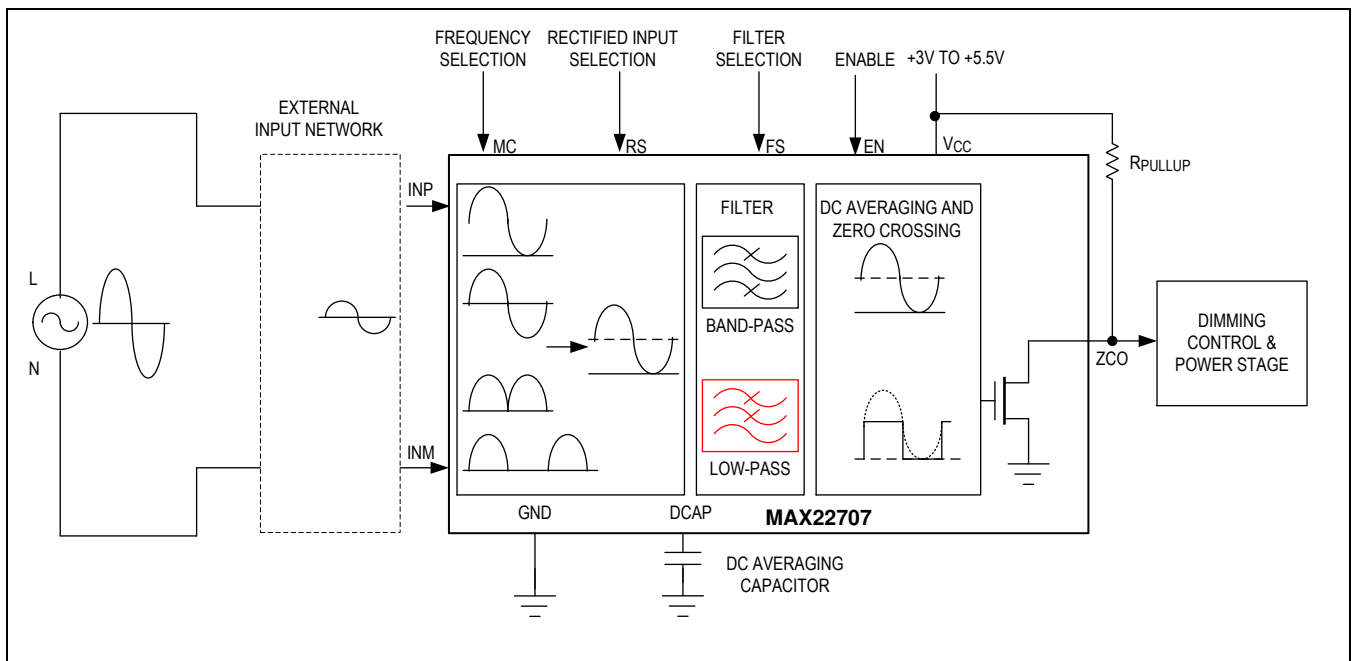



## Detailed Description

The MAX22707 precision zero crossing detector provides a reliable and repeatable zero crossing detection signal based on an AC line input. The use of switched-capacitor filters helps to ensure minimal zero-crossing delay while tracking change in the input frequency and provides higher precision and a more inherently stable output than discrete solutions.

The MAX22707 features a low-power, precision analog filter based on the switched-capacitor technology designed for precision filtering of AC input noise. The device requires only a simple external input network preceding the AC inputs and no additional external components for the filters. The two different filter types can be selected by the Filter Selection pin (FS). The available filter types are the fourth order BPF and LPF. The DC averaging filter capacitor function is used for the latter.

The MAX22707 supports two standard line frequencies (50Hz and 60Hz) for both the filter types as well as rectified inputs in the case of LPF. If the BPF is selected, then the frequency selection Mode Control pin (MC) is used to select between 50Hz and 60Hz. If the LPF is selected, then the same pin is used to choose between 50/60Hz or 100/120Hz signal band (see [Table 1](#)). The Rectified Select pin (RS) is used to select between sine and rectified units (see [Table 2](#)). The MAX22707 is available in a compact 10-pin  $\mu$ MAX package and operates over the  $-40^{\circ}\text{C}$  to  $+125^{\circ}\text{C}$  temperature range.

## Mode Control

The combination of Mode Control (MC) and Filter Select (FS) inputs determine the application mode from Type 1 to 4 as described in the section [Input Types: Bipolar and Unipolar](#).

**Table 1. Mode Control – Selecting the Input Frequency**

| Mode Control (MC) | Filter Select (FS) = 0, LPF | Filter Select (FS) = 1, BPF |
|-------------------|-----------------------------|-----------------------------|
| 0                 | 50 / 60Hz                   | 50Hz                        |
| 1                 | 100 / 120Hz                 | 60Hz                        |

## Input Stage Requirements

The input stage connected to the MAX22707 is comprised of a voltage divider that attenuates the high voltage AC line to the device input level and an anti-aliasing filter for the internal switched capacitor circuits. The MAX22707 handles both asymmetrical (SE) and symmetrical (DF) and bipolar and unipolar signals with the appropriate device configuration (FS, MC and RS) and the input network components.

When the LPF is selected (FS = 0), then the input stage has high voltage input with high ohmic series resistors ( $>100\text{k}\Omega$ ) in series and voltage divider to generate properly scaled single ended input signal to MAX22707 inputs (INP, INM). When the BPF is selected (FS = 1), then the input stage has the differential high voltage input with high ohmic series resistors ( $>100\text{k}\Omega$ ) in series and properly matched resistor divider feeding to the MAX22707 inputs (INP, INM). For the input types, see [Input Types: Bipolar and Unipolar](#). For the input network configurations, see [Input Network](#).

## Negative Input

When bipolar input mode is selected, the inputs INP and INM must stay between  $+V_{CC}$  and  $-V_{CC}$ . The input signal is filtered and compared with the ground reference to provide the zero-crossing signal.

## Rectified Input Selection

The combination of Rectified Selection (RS) and Filter Select (FS) inputs determine the correct configuration for input Types 1 and 2 (Sinewave) or Type 3 (fully rectified) and Type 4 (half rectified).

**Table 2. Rectified Selection**

| Rectified Selection (RS) | Filter Select (FS) = 0, LPF | Filter Select (FS) = 1, BPF |
|--------------------------|-----------------------------|-----------------------------|
| 0                        | Sinewave                    | Not a Valid State           |
| 1                        | Rectified                   | Not a Valid State           |

**Filters**

The MAX22707 has two different types of filters, LPF and BPF, which are selected by the FS input pin (low for LPF or high for BPF). When the LPF is selected, an external capacitor must be included at the DCAP pin to provide DC averaged reference for the zero-crossing detection operation.

**Input Types: Bipolar and Unipolar**

The MAX22707 requires an external R-C input network to attenuate the AC line input to acceptable signal levels, while also providing the anti-aliasing filtering (as required with a sampled system using switched capacitors). The output of the input network is a differential signal that is applied to the INP and INM pins, after which it is converted to a single-ended signal and level shifted to maximize the filter input and output ranges. The MAX22707 has six different input configurations, two bipolar and four unipolar, defined as Type 1 to 4 and described in the following figures:

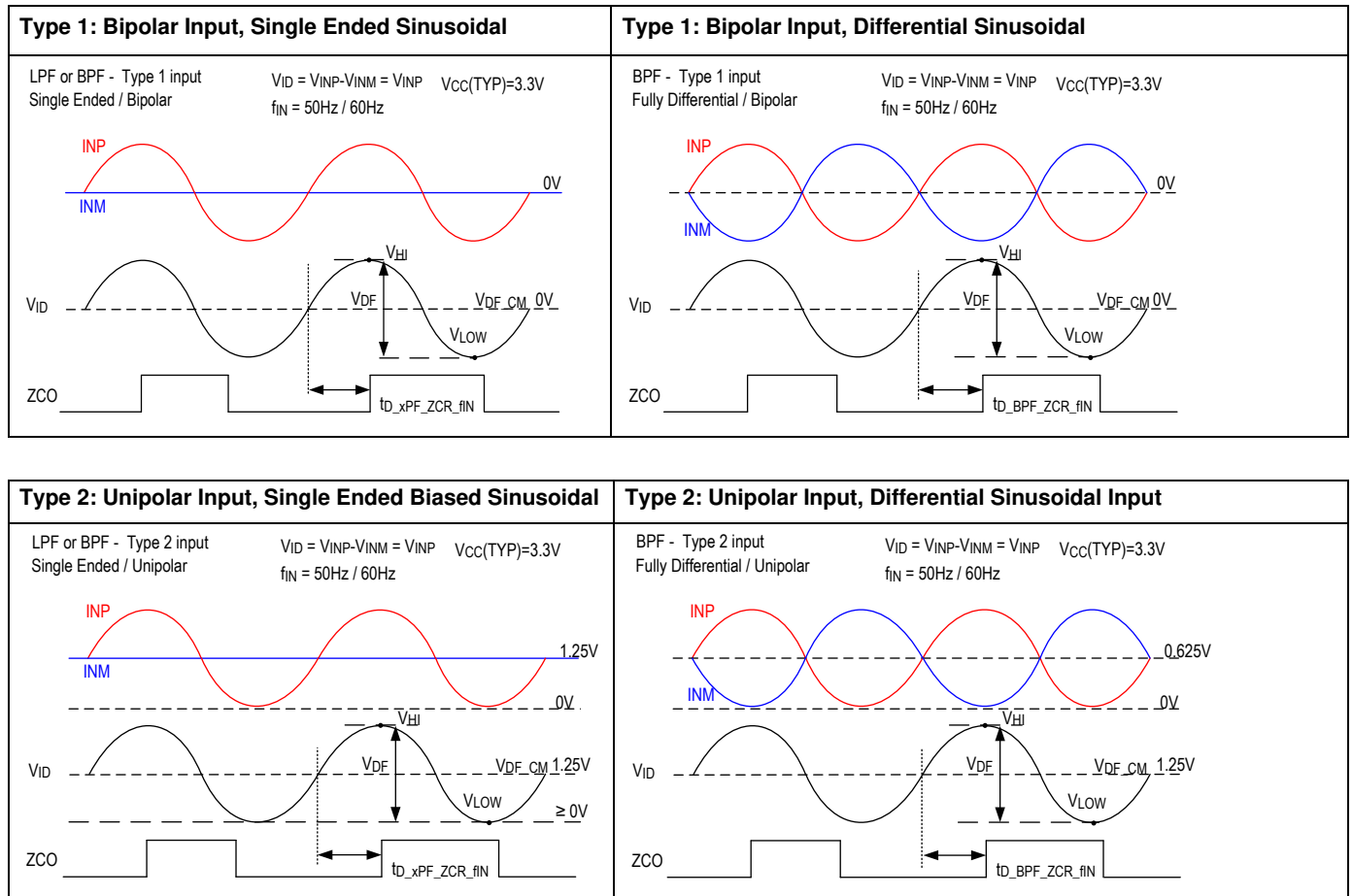

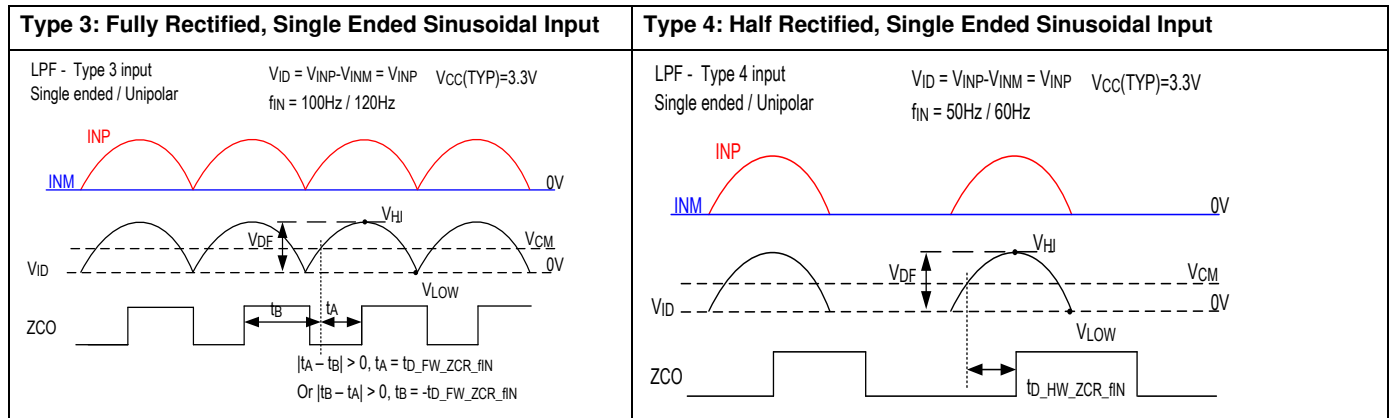

### Applications Information

#### Input Network

The external input network attenuates the input from AC line to the MAX22707 acceptable input range and performs anti-aliasing for the switched capacitor filters. See the [Figure 1](#) for the Input network for low pass configuration (left) and the [Figure 2](#) for the input network for band pass configuration (right).

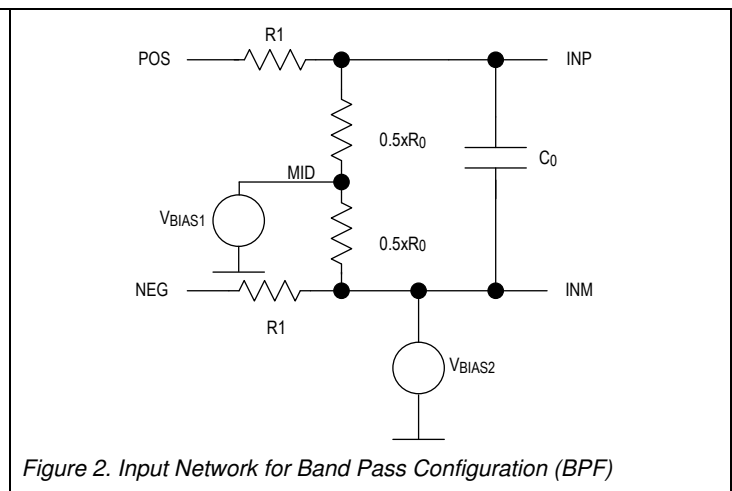
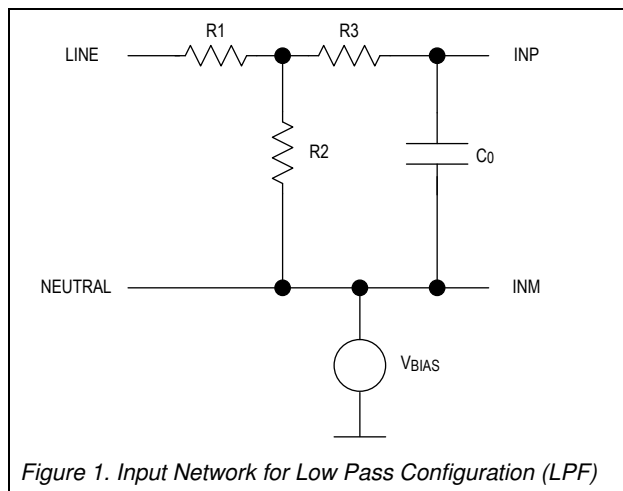

See below tables for input network values, [Table 3](#) for the LPF Configuration and [Table 4](#) for the BPF Configuration. The values shown for the input network for each input configuration attenuate 280V<sub>AC</sub> to 2.5V<sub>pk-pk</sub> and limit the bandwidth to 5kHz. The component values below may be modified for different AC standards while ensuring a 2.5V<sub>pk-pk</sub> full-scale signal at MAX22707 inputs and maintaining a high input series resistance (>100kΩ). If the AC input has been attenuated, in the case of the LPF input configuration R1 and R2 may be omitted.

**Table 3. Input Network Values for the LPF Configuration**

| Input network configuration | Type | Input | R1 (Ω) | R2 (Ω) | R3 (Ω) | C0 (nF) | VBIAS (V) |
|-----------------------------|------|-------|--------|--------|--------|---------|-----------|
| LPF                         | 1    | SE    | 200k   | 633    | 1447   | 22      | 0         |
|                             | 2    | SE    | 200k   | 633    | 1447   | 22      | 1.25      |
|                             | 3,4  | SE    | 200k   | 1271   | 1447   | 22      | 0         |

**Table 4. Input Network Values for the BPF Configuration**

| Input network configuration | Type | Input | R1 ( $\Omega$ ) | R0 ( $\Omega$ ) | C <sub>0</sub> (nF) | V <sub>BIAS1</sub> (V) | V <sub>BIAS2</sub> (V) |
|-----------------------------|------|-------|-----------------|-----------------|---------------------|------------------------|------------------------|
| BPF                         | 1    | DF    | 229k            | 1452            | 22                  | 0                      | n/a                    |
|                             | 1    | SE    | 229k            | 1452            | 22                  | n/a                    | 0                      |
|                             | 2    | DF    | 229k            | 1452            | 22                  | 0.625                  | n/a                    |
|                             | 2    | SE    | 229k            | 1452            | 22                  | n/a                    | 1.25                   |

### Full Wave Rectified Inputs

As listed in the [Electrical Characteristics](#), the delay repeatability is performed without noise. This is vital in the full-wave rectified case since any imperfection of the rectified input signal results in worse zero-crossing time delay repeatability. The repeatability as specified in the Electrical Characteristics applies for an ideal full wave rectified signal.

The imperfection may result from the method of rectification or from the noise. In either case, the magnitude of the delay repeatability is larger than for an ideal signal since the input waveform is not periodic. As an example of the former case, a full wave rectified input is commonly generated as a composite signal. Given the tolerance of discrete components, some finite phase delay exists between the various paths of the constituent signals, resulting in phase delay between adjacent lobes of the rectified signal and worse zero-crossing delay repeatability.

### Power Supply

The MAX22707 does not require special power supply sequencing. It is recommended to bypass V<sub>CC</sub> supply with a 0.1 $\mu$ F low-ESR ceramic capacitor placed as close to the device V<sub>CC</sub> pin as possible.

### ESD and EMC Testing

The MAX22707 is required to operate reliably in harsh industrial environments. The device can meet the transient immunity requirements as specified in IEC 61000-4, including Electrostatic Discharge (ESD) per IEC 61000-4-2, Electrical Fast Transient/Burst (EFT) per IEC 61000-4-4, and Surge Immunity per IEC 61000-4-5. Maxim's proprietary process technology provides robust input channels and power supply with internal ESD structures and high Absolute Maximum Ratings, but external components are also required to absorb excessive energy from ESD and surge transients. For more information on the input circuit schematic and components, refer to the MAX22707 EV Kit data sheet that allows MAX22707 to meet transient levels as listed in [Table 5](#).

**Table 5. ESD and Transient Immunity Characteristics**

| PARAMETER | SYMBOL           | CONDITIONS  | VALUE    | UNITS |
|-----------|------------------|---|----------|-------|
| Surge     | IN_ to Earth GND | $\geq 100k\Omega$ input resistor from Line to System / Earth Ground, IEC 61000-4-5<br>1.2 $\mu$ s/50 $\mu$ s pulse  | $\pm 6$  | kV    |
|           | IN_ to IN_       | $\geq 100k\Omega$ input resistor from Line (Live) to Line (Neutral), IEC 61000-4-5<br>1.2 $\mu$ s/50 $\mu$ s pulse  | $\pm 6$  |       |
| EFT       | IN_ to Earth GND | Power line cable in capacitive clamp to input cable pair (IN_ to GND) with<br>$\geq 100k\Omega$ input resistor from Line to GND, IEC61000-4-4   | $\pm 3$  |       |
| ESD       | IN_ Contact      | $\geq 100k\Omega$ input resistor in series with IN_ with respect to GND, IEC61000-4-2.<br>LPF Mode: External TVS diode at INM to GND, optional external TVS diode at INP to GND,<br>BPF Mode: Optional external TVS diode at INP to GND and INM to GND. | $\pm 8$  |       |
|           | IN_ Air Gap      | $\geq 100k\Omega$ input resistor in series with IN_ with respect to GND, IEC61000-4-2.<br>LPF Mode: External TVS diode at INM to GND, optional external TVS diode at INP to GND,<br>BPF Mode: Optional external TVS diode at INP to GND and INM to GND. | $\pm 15$ |       |

**Layout Considerations**

The PCB designer should follow some critical recommendations to get the best performance from the design:

- Keep the input/output traces as short as possible. To keep signal path low inductance, avoid using vias.
- Have a solid ground plane underneath the input-output signal layer.
- Ensure to have ground keep-out from high voltage input interface.
- Ensure to maintain right creepage and clearance between components and traces at the input network until the signal is low voltage.

**Typical Application Circuits**

The MAX22707 can be used with any combination of input types (single ended/differential inputs) and polarity (unipolar/bipolar). Different R-C attenuation networks are recommended for the different input configurations the MAX22707 can be used in. See the [Input Network](#) section to calculate the input network components for the specific input level and type. [Table 6](#) shows the applications modes.

**Table 6. Application Modes**

| FS | MC | RS | Mode                                      | Refer to Figure                     |
|----|----|----|---|-------------------------------------|
| 0  | 0  | 0  | Sinewave input, 50/60Hz, LPF              | <a href="#">Figure 3, Figure 4</a>  |
| 0  | 1  | 0  | Not a Valid State                         | N/A                                 |
| 0  | 1  | 1  | Full Wave Rectified Input, 50/60Hz, LPF   | <a href="#">Figure 5</a>            |
| 0  | 0  | 1  | Half Wave Rectified Input, 100/120Hz, LPF | <a href="#">Figure 6</a>            |
| 1  | 0  | 0  | Sinewave input, 50Hz, BPF                 | <a href="#">Figure 8, Figure 9</a>  |
| 1  | 1  | 0  | Sinewave input, 60Hz, BPF                 | <a href="#">Figure 7, Figure 10</a> |
| 1  | 0  | 1  | Not a Valid State                         | N/A                                 |
| 1  | 1  | 1  | Not a Valid State                         | N/A                                 |

**LPF for the Bipolar Sinewave Single Ended 50/60Hz Input**

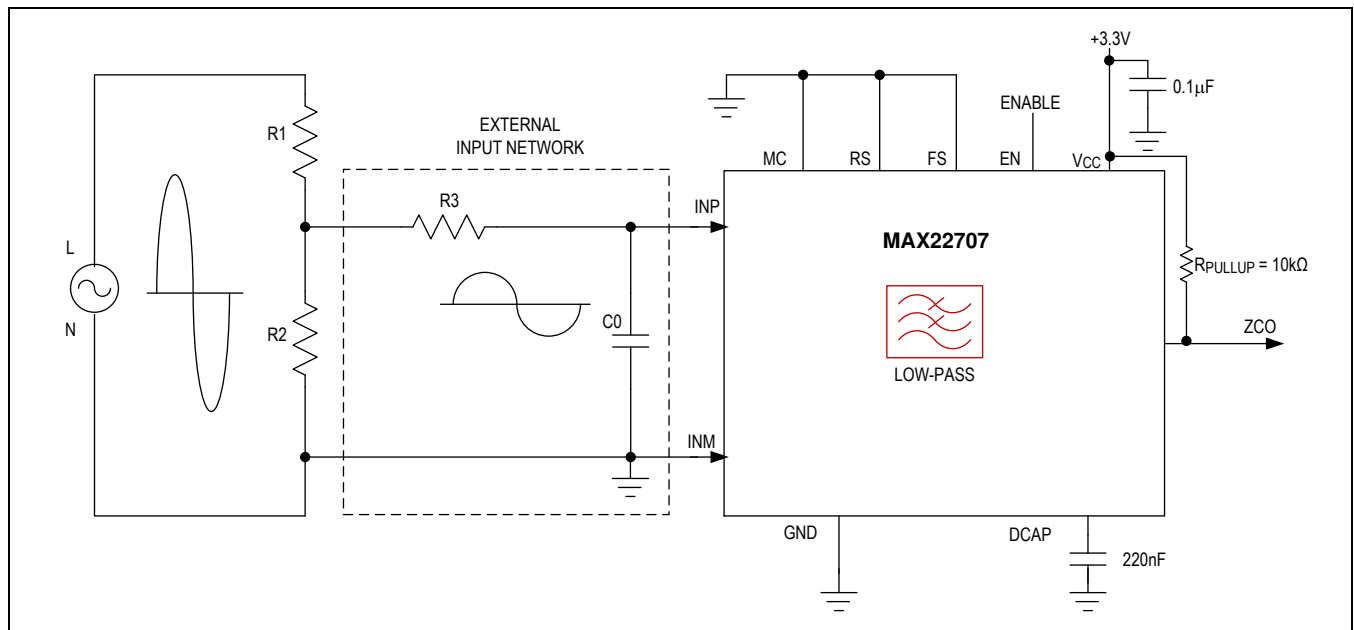

Figure 3. LPF for the Bipolar Sinewave Single Ended 50/60Hz Input

**LPF for the Unipolar Biased Single Ended 50/60Hz Input**

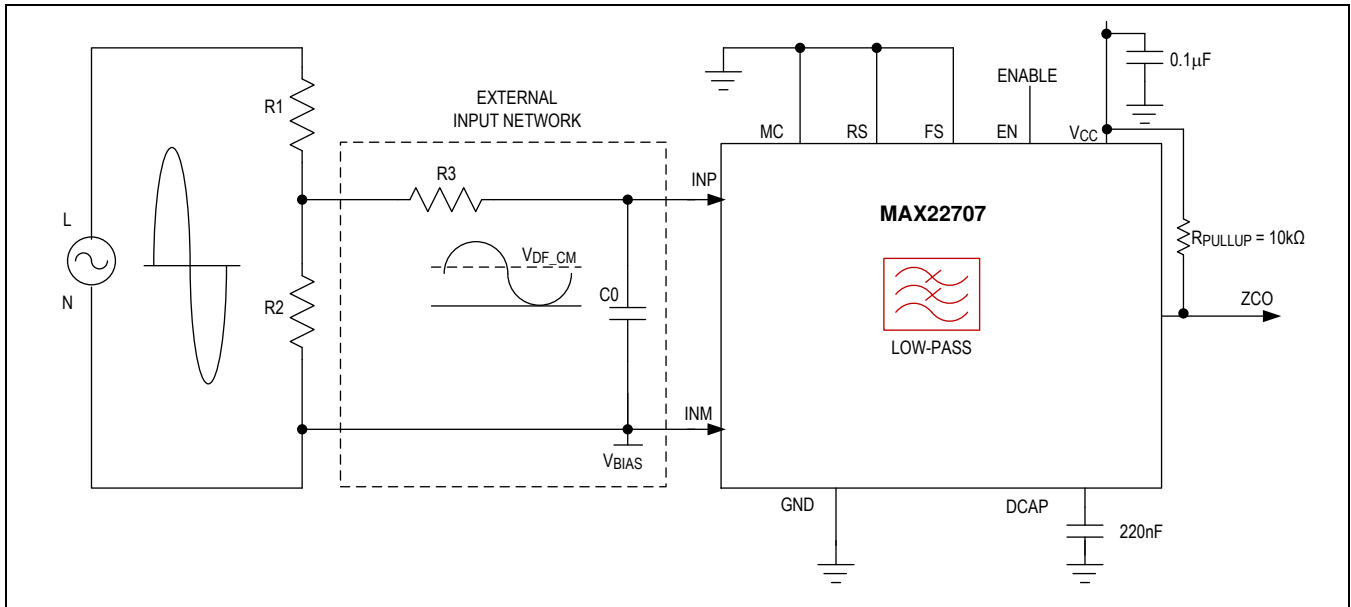

Figure 4. LPF for the Unipolar Biased Single Ended 50/60Hz Input

**LPF for the Full-Rectified 100/120Hz Input**

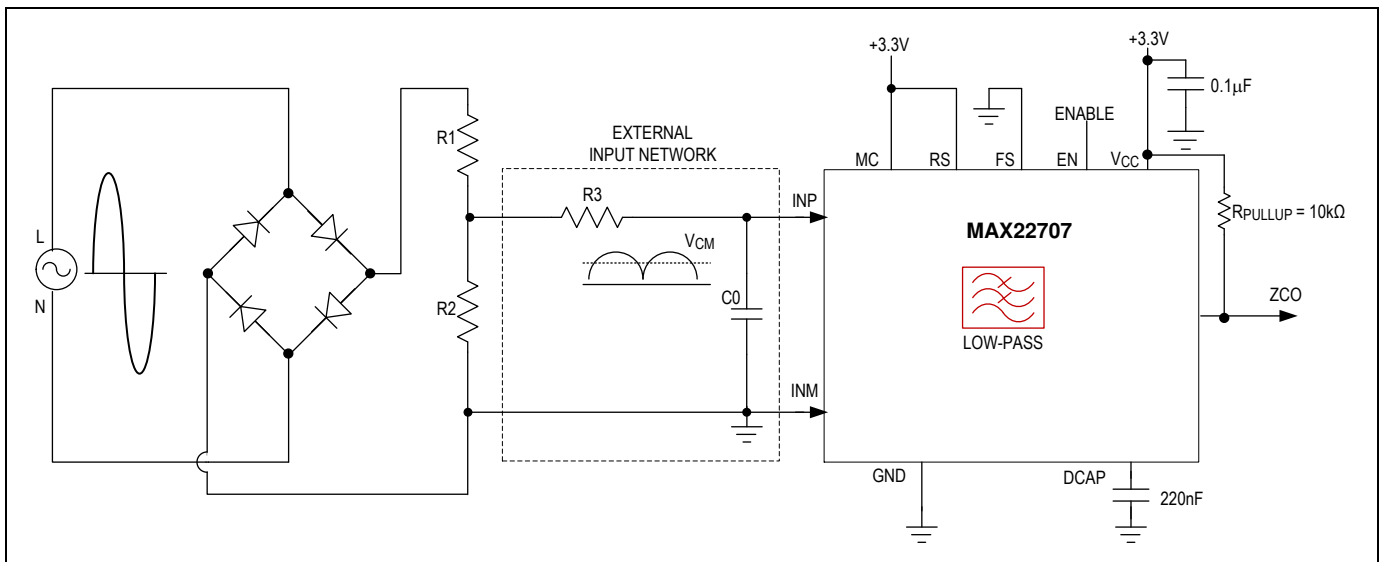

Figure 5. LPF for the Full-Rectified 100/120Hz Input

**LPF for the Half-Rectified 50/60Hz Input**

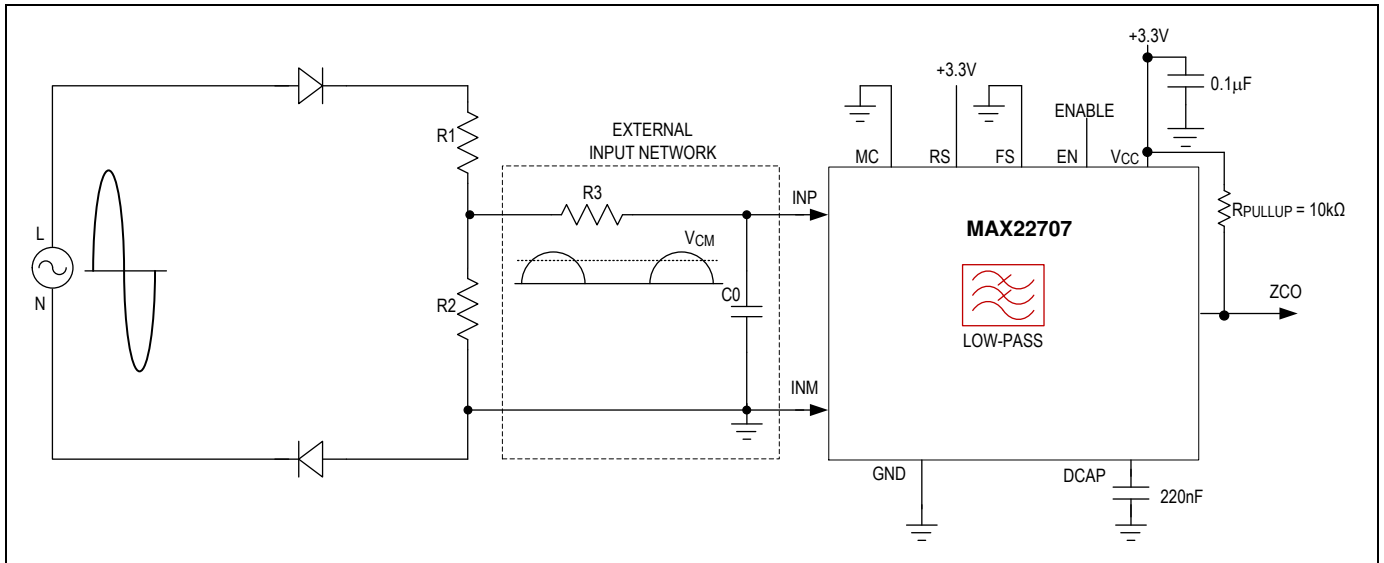

Figure 6. LPF for the Half-Rectified 50/60Hz Input

**BPF for the Bipolar Differential 60Hz Input**

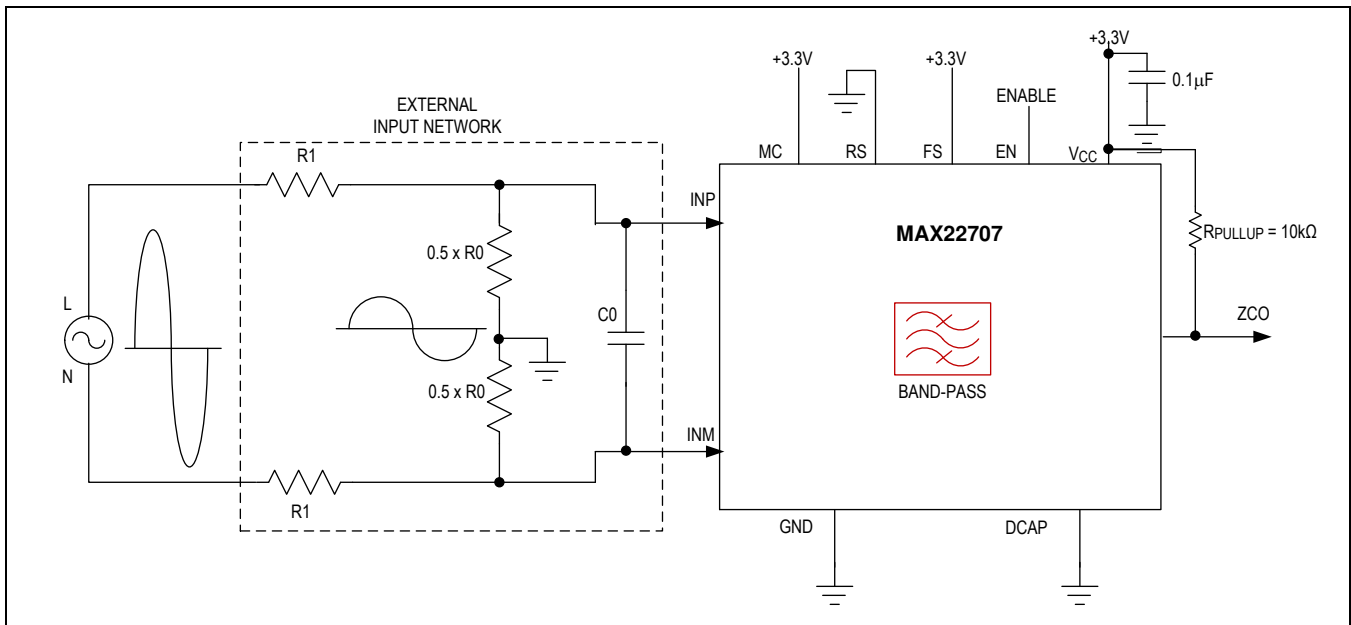

Figure 7. BPF for the Bipolar Differential 60Hz Input



**BPF for the Bipolar Single Ended 50Hz Input**

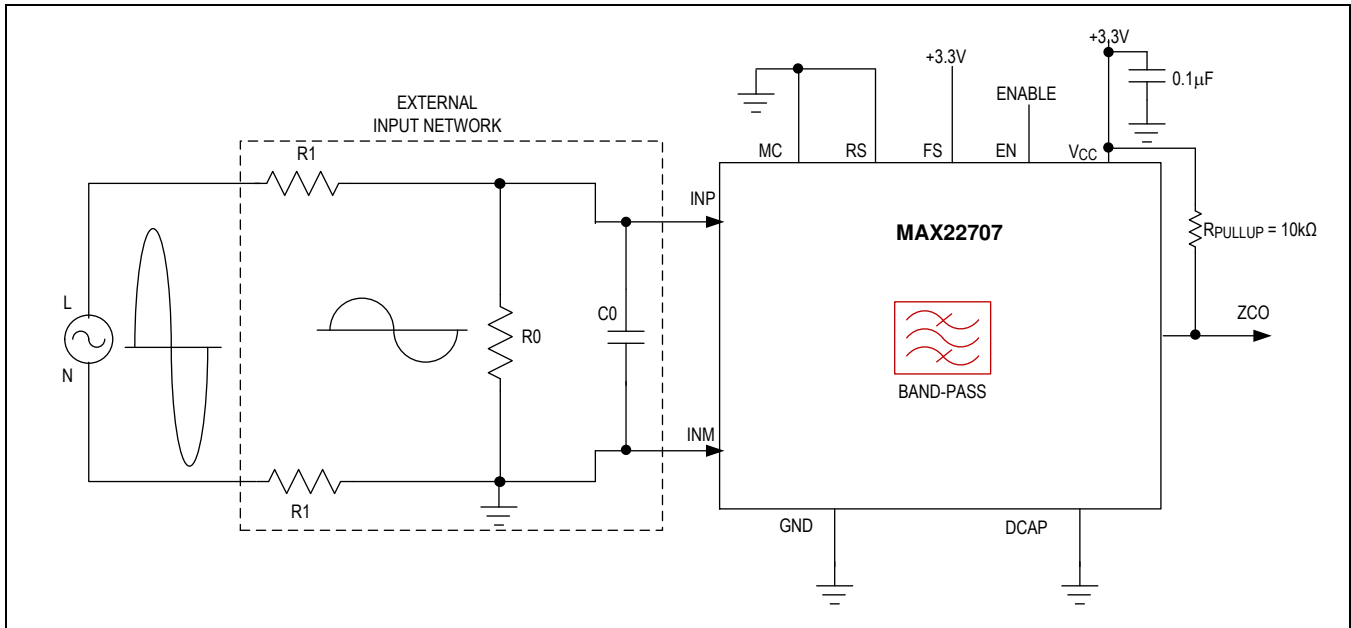

Figure 8. BPF for the Bipolar Single Ended 50Hz Input

**BPF for the Unipolar Biased Differential 50Hz Input**

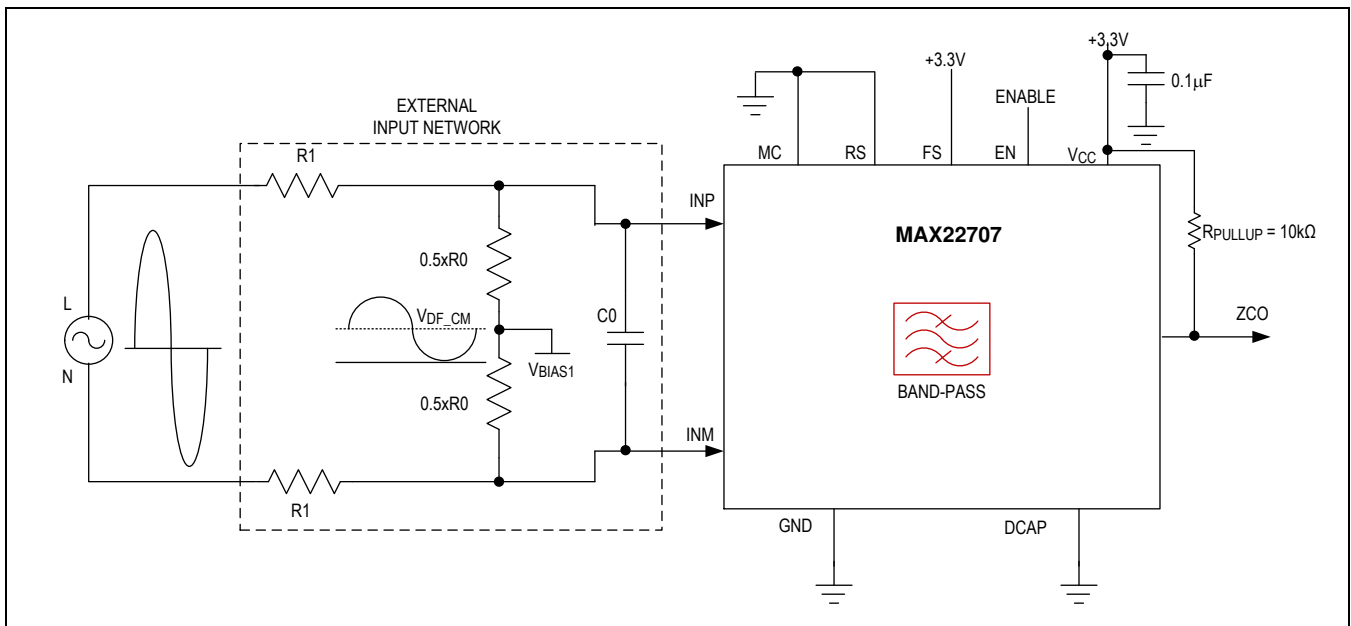

Figure 9. BPF for the Unipolar Biased Differential 50Hz Input

**BPF for the Unipolar Biased Single Ended 60Hz Input**

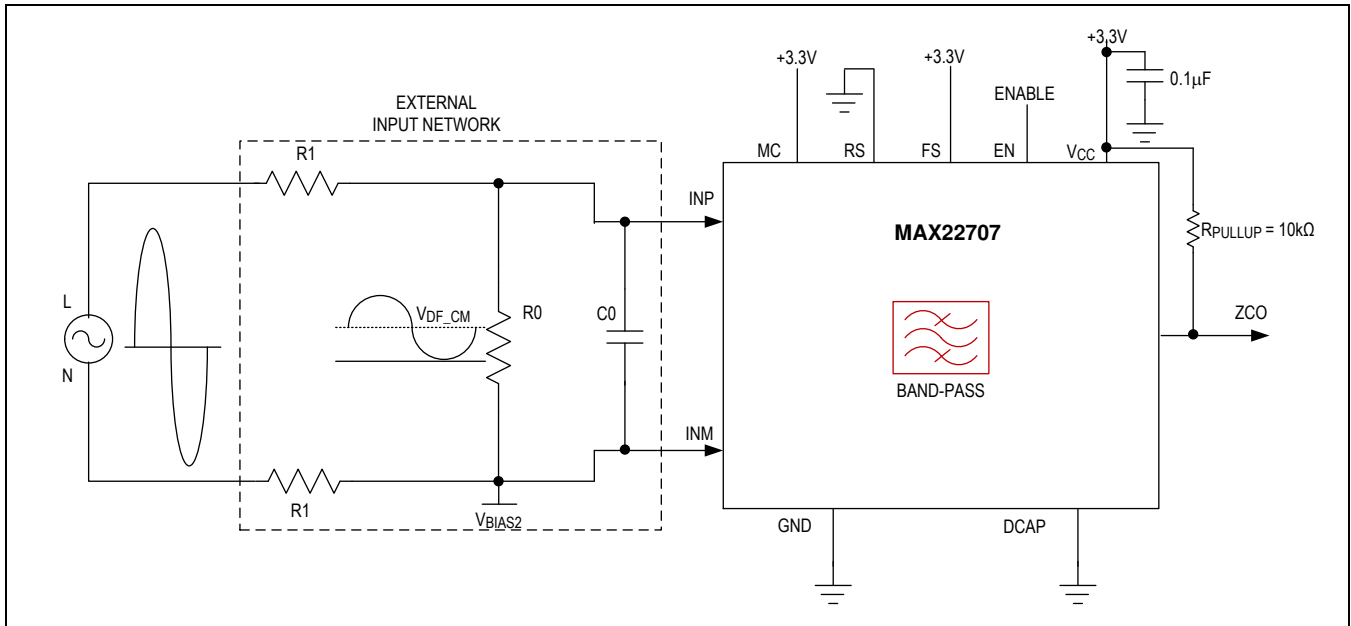

Figure 10. BPF for the Unipolar Biased Single Ended 60Hz Input

**Ordering Information**

| PART NUMBER   | TEMP RANGE      | PIN-PACKAGE |
|---------------|-----------------|-------------|
| MAX22707AUB+  | -40°C to +125°C | 10-pin μMAX |
| MAX22707AUB+T | -40°C to +125°C | 10-pin μMAX |

+Denotes a lead(Pb)-free/RoHS-compliant package.

T = Tape-and reel.

**Chip Information**

PROCESS: BiCMOS

## Revision History

| REVISION NUMBER | REVISION DATE | DESCRIPTION              | PAGES CHANGED |
|-----------------|---------------|--------------------------|---------------|
| 0               | 12/21         | Release for Market Intro | —             |

