

THIS DOCUMENT AND THE DATA DISCLOSED HEREIN OR HEREWITH IS NOT TO BE REPRODUCED, USED OR DISCLOSED IN WHOLE OR IN PART TO ANYONE WITHOUT THE PERMISSION OF VICOR CORP.

REV.	DESCRIPTION	DATE	APPROVED
1	RELEASED PER E050348	11/15/05	ECF
2	REVISED PER E072386	10/02/07	REJH
3	REVISED PER E090033	01/09/09	REJH
4	REVISED PER E091548	09/03/09	REJH
5	REVISED PER E100902	7/14/10	KUK
6	REVISED PER E111105	11/11/11	REJH

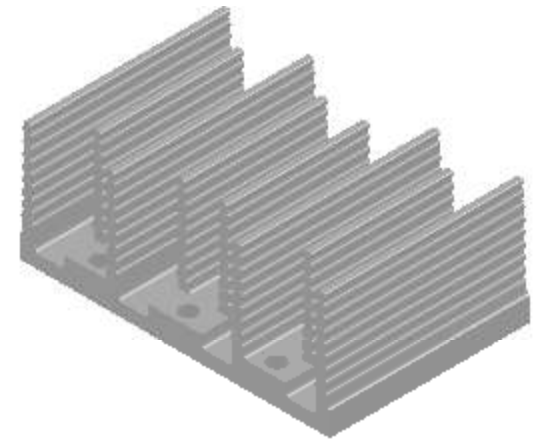
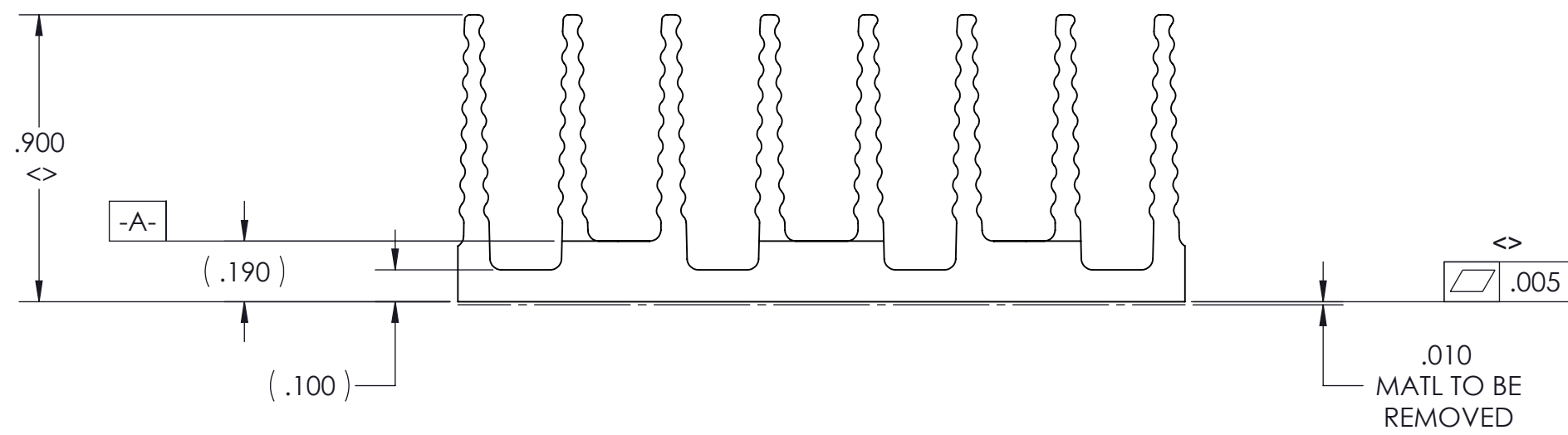
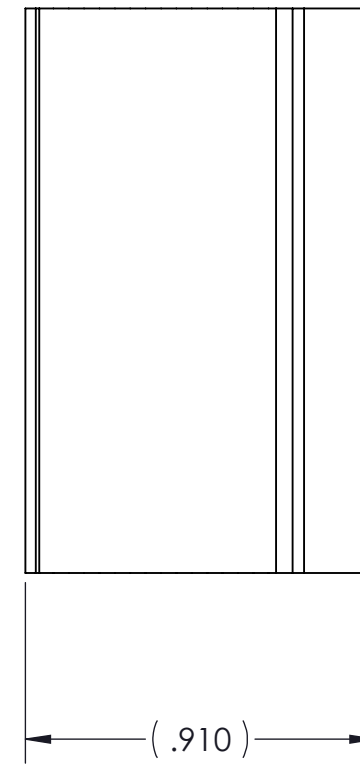
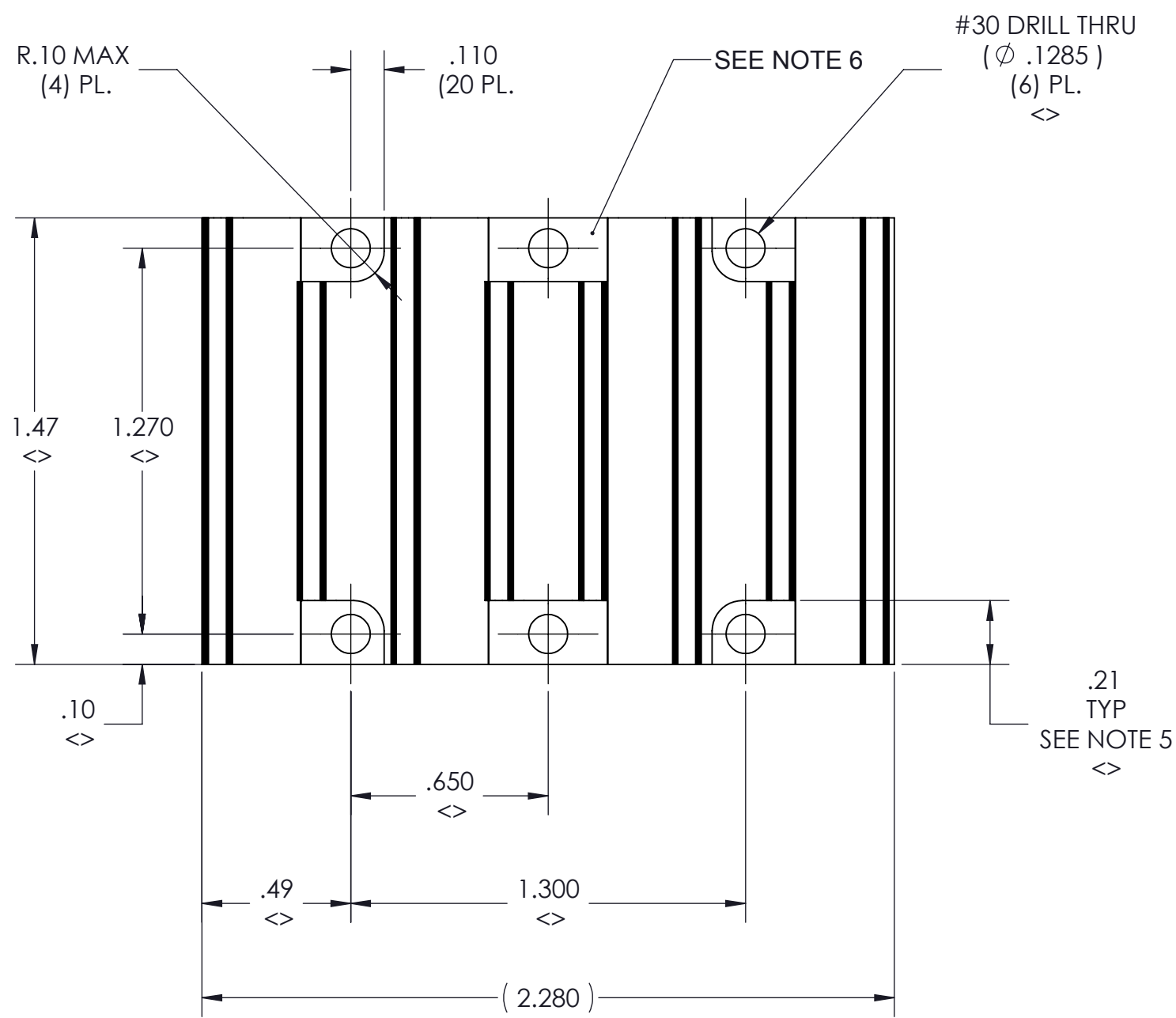
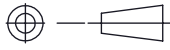

- NOTES:
1. MATERIAL: EXTRUSION SEE SHEET 2 OF 2.
  2. REMOVE ALL BURRS AND SHARP EDGES.
  3. CLEAR FINISH, RoHS COMPLIANT, PER CST-0001 LATEST REVISION PER:  
A.) CHROMIUM FREE, OR  
B.) TRIVALENT CHROMIUM IN ACCORDANCE WITH MIL-DTL-5541, TYPE II CLASS 1A OR 3.  
SEE CST-0003 FOR TYPES OF AVAILABLE FINISHES
  4. "<>" DENOTES CRITICAL CHARACTERISTIC FOR LOT INSPECTION.
  5. DIMENSIONS APPLIES AT SURFACE -A- (2) PL.
  6. MACHINED SURFACE TO BE .010 MAX BELOW SURFACE -A- (6) PL.
  7. DIMENSIONS ARE INCHES ONLY.

DRAWN BY David Schmidt	DATE 06/28/2010	<b>VICOR</b> SWD	
UNLESS OTHERWISE SPECIFIED DIMENSIONS ARE : INCH / (MM)		<b>HTSNK, "C" X-FLOW, .9H LOW FLOW, THRU HOLE</b>	
TOLERANCES ARE: DECIMALS ±.01 (0.25) X.XXX [X.XX] = ±0.005 (0.127)		SIZE <b>C</b>	CAGE CODE <b>67131</b>
THIRD ANGLE PROJECTION  DO NOT SCALE DRAWING		DWG NO <b>30725</b>	REV <b>6</b>
SCALE 2:1		SHEET 1 OF 2	

VICOR CONFIDENTIAL  
THIS DOCUMENT AND THE DATA DISCLOSED HEREIN OR  
HEREWITH IS NOT TO BE REPRODUCED, USED OR  
DISCLOSED IN WHOLE OR IN PART TO ANYONE WITHOUT  
THE PERMISSION OF VICOR CORP.

REVISIONS			
REV	DESCRIPTION	DATE	APPROVED
	SEE SHEET 1		

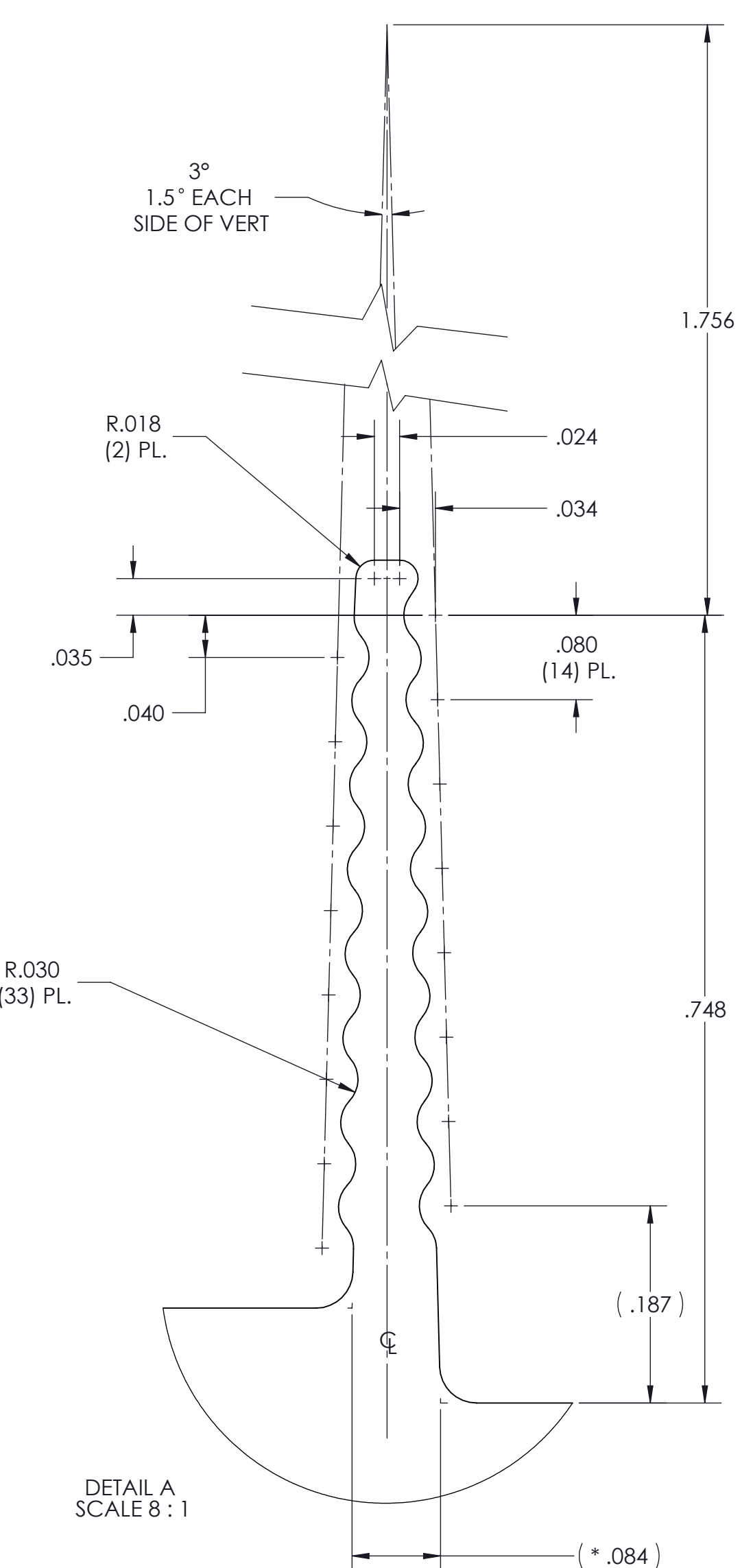
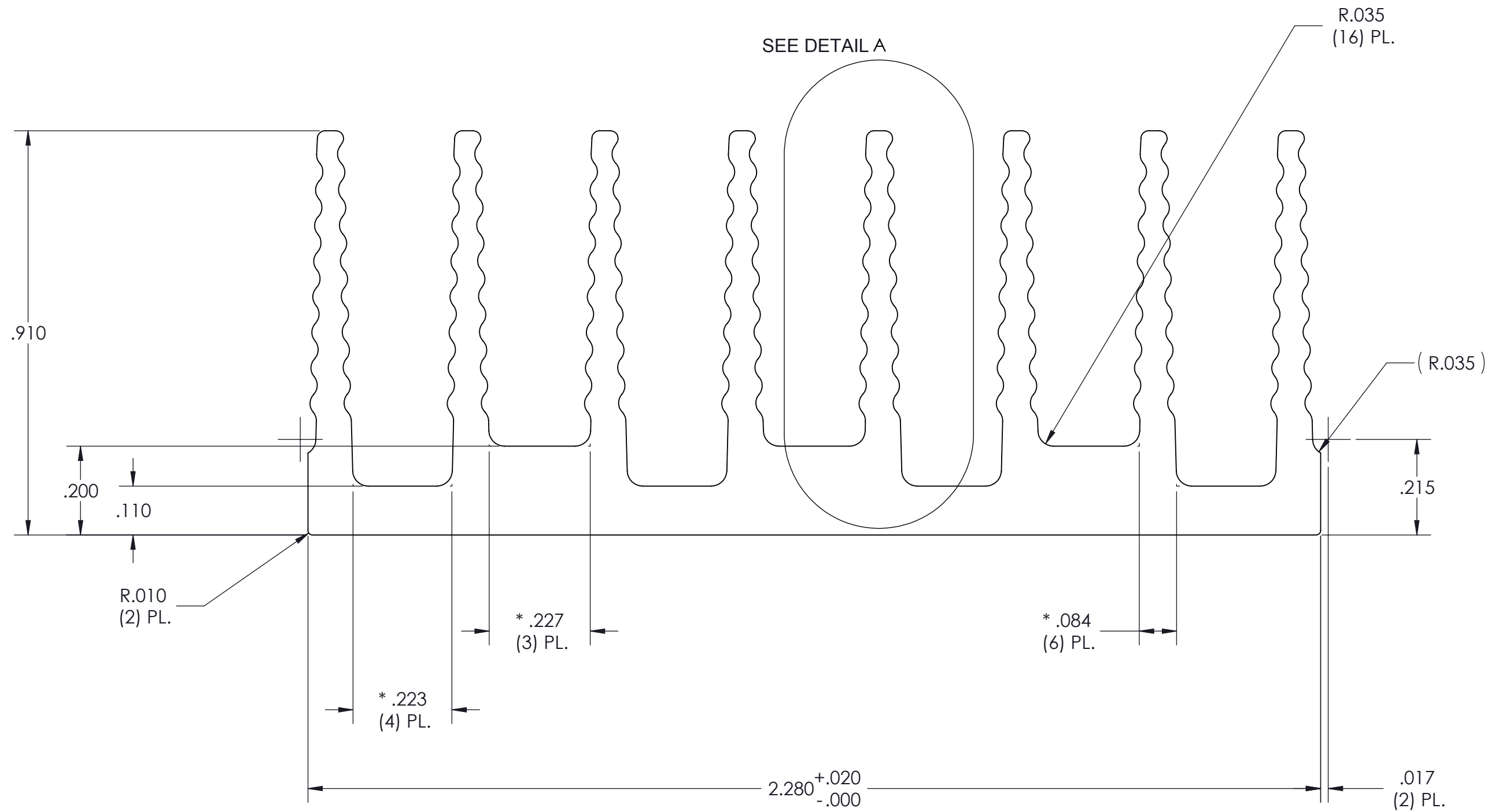

PROFILE COMMON FOR
30270
30724
30269
30725

- NOTES:
- MATL: ALUMINUM 6063-T5
  - \* DENOTES DIMENSION TO THEORETICAL SHARP CORNER.
  - ALL DIMENSIONS ARE CRITICAL CHARACTERISTICS.
  - RoHS COMPLIANT PER CST-0001 LATEST REVISION.
  - WORKMANSHIP STANDARDS WS-0004, WS-0006 AND WS-0007 APPLY TO THIS PART.
  - DIMENSIONS ARE INCHES ONLY.

DRAWN BY David Schmidt	DATE 06/28/2010	SWD	
UNLESS OTHERWISE SPECIFIED DIMENSIONS ARE : INCH / (MM)		<b>HTSNK, "C" X-FLOW, .9H LOW FLOW, THRU HOLE EXTRUSION</b>	
TOLERANCES ARE: DECIMALS ANGLES X.XX [X.X] = ±0.01 [0.25] ±1° X.XXX [X.XXX] = ±0.005 [0.127]			
THIRD ANGLE PROJECTION 	SIZE <b>C</b>	CAGE CODE <b>67131</b>	DWG NO <b>30725</b>
DO NOT SCALE DRAWING	SCALE 2:1	REV <b>6</b>	
		SHEET 2 OF 2	