

## General Description

The AOZ6622DI is a high efficiency, easy to use, 2A synchronous buck regulator. The AOZ6622DI works from 4.5V to 18V input voltage range, and provides up to 2A of continuous output current with an output voltage adjustable down to 0.8V.

The AOZ6622DI comes in a DFN 3mm x 3mm package and is rated over a -40°C to +85°C operating ambient temperature range.

## Features

- 4.5V to 18V operating input voltage range
- Synchronous Buck: 150mΩ internal high-side switch and 90mΩ internal low-side switch
- Up to 95% efficiency
- Pulse energy mode for high light load efficiency (Vin=12V, Vo=5V, 83% @10mA)
- Output voltage adjustable to 0.8V
- Adjacent pin short protection
- 2A continuous output current
- 550kHz PWM operation
- Cycle-by-cycle current limit
- Pre-bias start-up
- Short-circuit protection
- Thermal shutdown

## Applications

- Point of load DC/DC converters
- LCD TV
- Set top boxes
- DVD / Blu-ray players/recorders
- Cable modems



## Typical Application

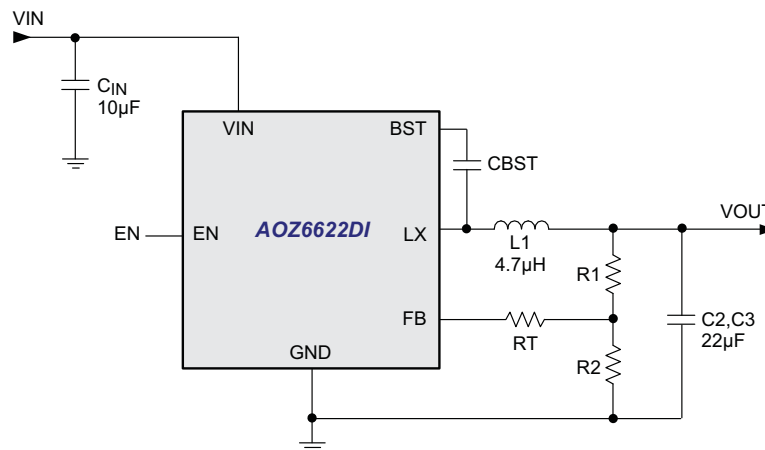

Figure 1. 3.3V 2ASynchronous Buck Regulator, Fs = 550kHz

## Ordering Information

Part Number	Ambient Temperature Range	Package	Environmental
AOZ6622DI	-40°C to +85°C	8-Pin 3mm x 3mm DFN	Green Product



AOS Green Products use reduced levels of Halogens, and are also RoHS compliant. Please visit [www.aosmd.com/media/AOSGreenPolicy.pdf](http://www.aosmd.com/media/AOSGreenPolicy.pdf) for additional information.

## Pin Configuration

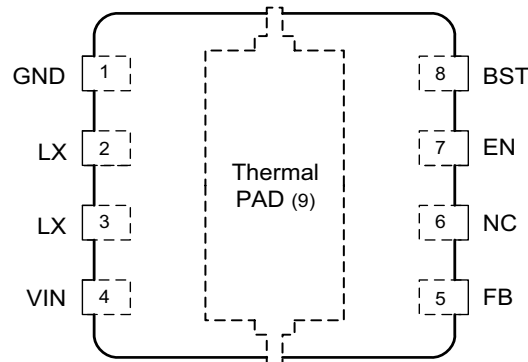

8-Pin 3mm x 3mm DFN  
(Top View)

## Pin Description

Pin Number	Pin Name	Pin Function
1	GND	System ground.
2, 3	LX	Switching output.
4	VIN	Supply voltage input. When VIN rises above the UVLO threshold and EN is logic high, the device starts up.
5	FB	Feedback input. The FB pin is used to set the output voltage via a resistive voltage divider between the output and GND.
6	NC	No connection.
7	EN	Enable pin. Pull EN to logic high to enable the device. Pull EN to logic low to disable the device. If on/off control is not needed, connect it to VIN and do not leave it open.
8	BST	Bootstrap.
9	Thermal PAD	GND pin must be connected to the exposed pad for proper operation.

## Absolute Maximum Ratings<sup>(1)</sup>

Exceeding the Absolute Maximum Ratings may damage the device.

Parameter	Rating
Supply Voltage ( $V_{IN}$ )	20V
LX to GND	-0.7V to $V_{IN}+0.3V$
LX to GND (20ns)	-5V to 22V
EN to GND	-0.3V to $V_{IN}+0.3V$
BST to GND	26V
BST to LX	6V
Junction Temperature ( $T_J$ )	+150°C
Storage Temperature ( $T_S$ )	-65°C to +150°C
ESD Rating <sup>(2)</sup>	2kV

### Notes:

- Exceeding the Absolute Maximum ratings may damage the device.
- Devices are inherently ESD sensitive, handling precautions are required. Human body model rating: 1.5k $\Omega$  in series with 100pF.

## Electrical Characteristics

$T_A = 25^\circ\text{C}$ ,  $V_{IN} = V_{EN} = 12V$ ,  $V_{OUT} = 3.3V$ , unless otherwise specified<sup>(5)</sup>.

Symbol	Parameter	Conditions	Min.	Typ.	Max	Units
$V_{IN}$	Supply Voltage		4.5		18	V
$V_{UVLO}$	Input Under-Voltage Lockout Threshold	$V_{IN}$ rising $V_{IN}$ falling	3.4	4.1 3.7	4.35	V V
$I_{IN}$	Supply Current (Quiescent)	$I_{OUT} = 0V$ , $V_{FB} = 1.2V$ , $V_{EN} > 2V$		0.55		mA
$I_{OFF}$	Shutdown Supply Current	$V_{EN} = 0V$		1	3	$\mu\text{A}$
$V_{FB}$	Feedback Voltage	$T_A = 25^\circ\text{C}$	0.784	0.800	0.816	V
$R_O$	Load Regulation	PWM mode $500\text{mA} < I_{Load} < 2A$		0.5		%
$S_V$	Line Regulation	$4.5V < V_{IN} < 18V$		1		%
$I_{FB}$	Feedback Voltage Input Current				100	nA
$V_{EN}$	EN Input Threshold	Off threshold On threshold	2		0.6	V V
$V_{HYS}$	EN Input Hysteresis			300		mV
$I_{EN}$	EN Input Current	$V_{EN} = 5V$		3	5	$\mu\text{A}$
$t_{SS}$	SS Time			1.5		ms
<b>Modulator</b>						
$f_O$	Frequency		400	550	660	kHz
$D_{MAX}$	Maximum Duty Cycle		88			%
$D_{MIN}$	Controllable Minimum Duty Cycle				7.5	%
<b>Protection</b>						
$I_{LIM}$	Current Limit		3.0	3.5		A
$T_{OTP}$	Over Temperature Shutdown Limit	$T_J$ rising $T_J$ falling		150 100		$^\circ\text{C}$ $^\circ\text{C}$

## Maximum Operating Ratings<sup>(3)</sup>

The device is not guaranteed to operate beyond the Maximum Operating ratings.

Parameter	Rating
Supply Voltage ( $V_{IN}$ )	4.5V to 18V
Output Voltage Range	0.8V to $0.85 \cdot V_{IN}$
Ambient Temperature ( $T_A$ )	-40°C to +85°C
Package Thermal Resistance ( $\theta_{JA}$ ) <sup>(4)</sup>	50°C/W

### Notes:

- The device is not guaranteed to operate beyond the Maximum Operating ratings.
- The value of  $\theta_{JA}$  is measured with the device mounted on a 1-in<sup>2</sup> FR-4 four layer board with 2oz copper and Vias, in a still air environment with  $T_A = 25^\circ\text{C}$ . The value in any given application depends on the user's specification board design.

## Electrical Characteristics

$T_A = 25^\circ\text{C}$ ,  $V_{IN} = V_{EN} = 12\text{V}$ ,  $V_{OUT} = 3.3\text{V}$ , unless otherwise specified<sup>(5)</sup>.

Symbol	Parameter	Conditions	Min.	Typ.	Max	Units
<b>Output Stage</b>						
$R_H$	High-Side Switch On-Resistance	$V_{BST-LX} = 5\text{V}$		150		$\text{m}\Omega$
$R_L$	Low-Side Switch On-Resistance	$V_{CC} = 5\text{V}$		90		$\text{m}\Omega$

**Note:**

5. The device is not guaranteed to operate beyond the Maximum Operating Ratings. Specifications in **Bold** indicate an ambient temperature range of  $-40^\circ\text{C}$  to  $+85^\circ\text{C}$ . These specifications are guaranteed by design.

### Functional Block Diagram

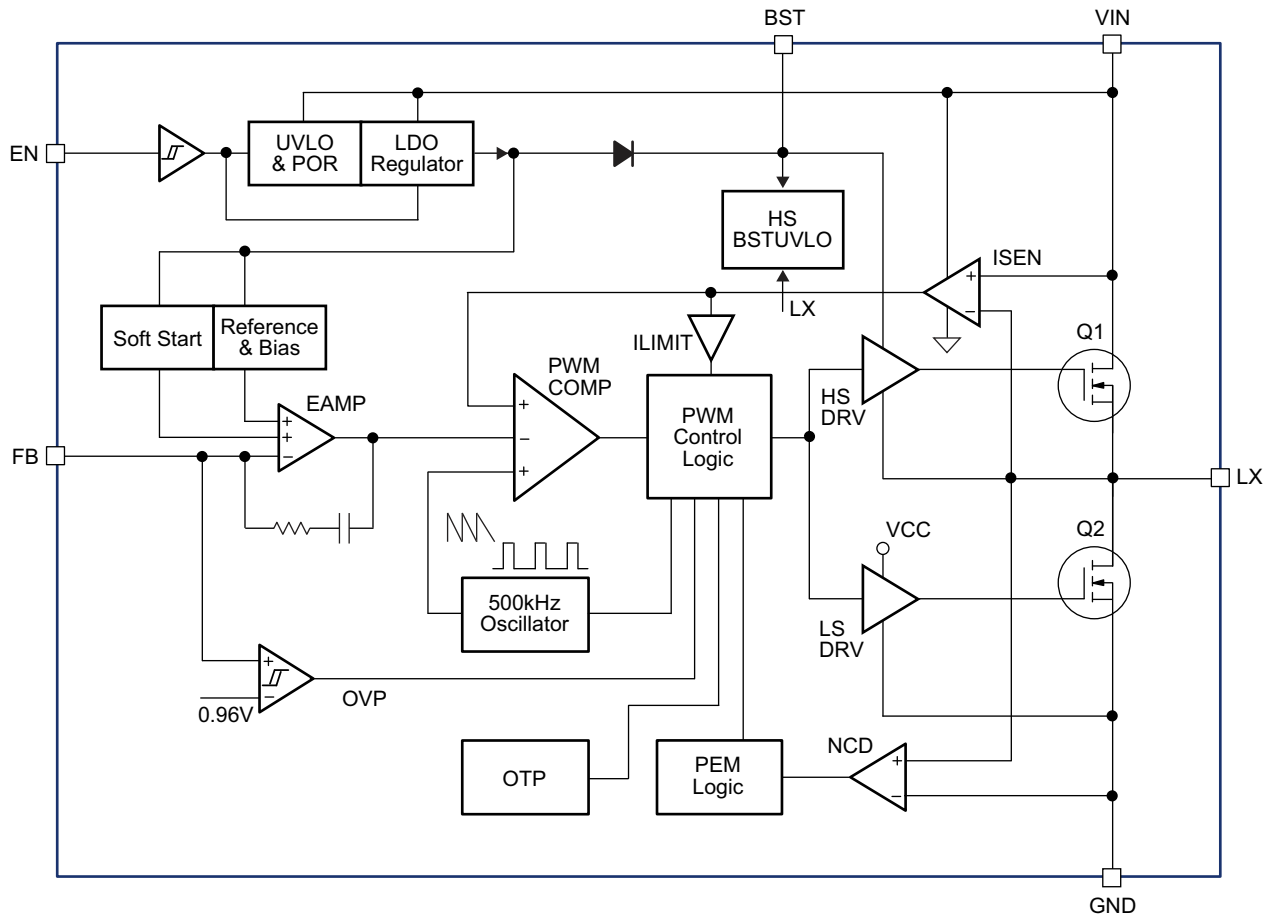

## Typical Characteristics

### Efficiency

Efficiency vs. Load Current (VIN=12V)

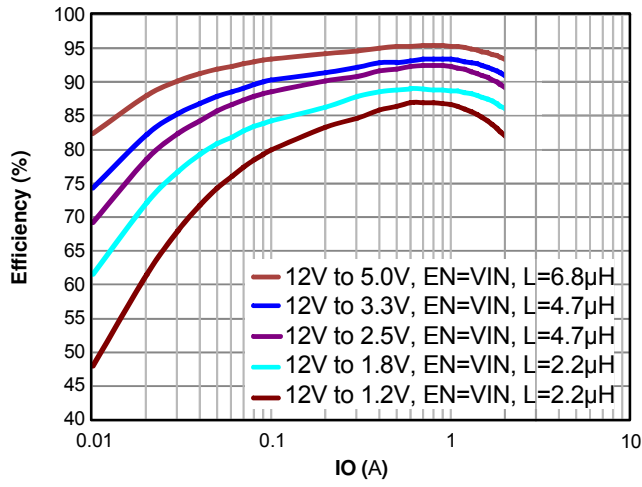

Efficiency vs. Load Current (VIN=5V)

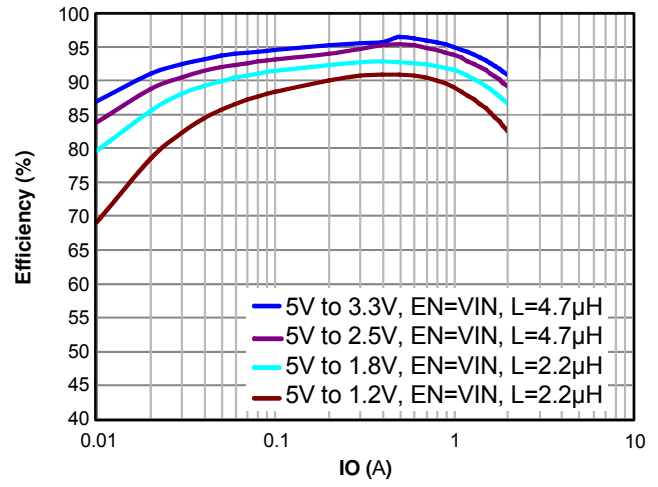

## Typical Characteristics

Circuit of Typical Application.  $T_A = 25^\circ\text{C}$ ,  $V_{IN} = V_{EN} = 12\text{V}$ ,  $V_{OUT} = 3.3\text{V}$ , unless otherwise specified.

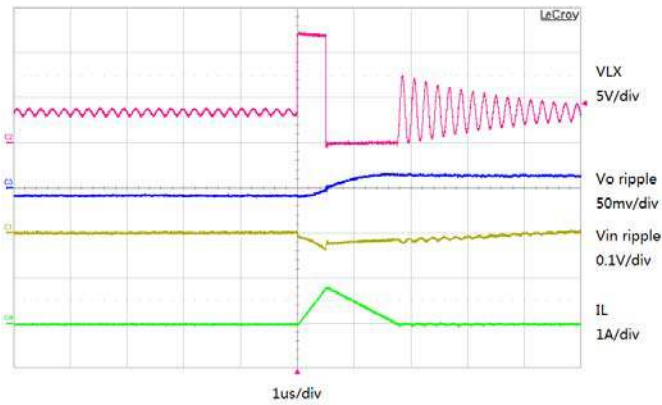

Figure 2. Light Load Operation

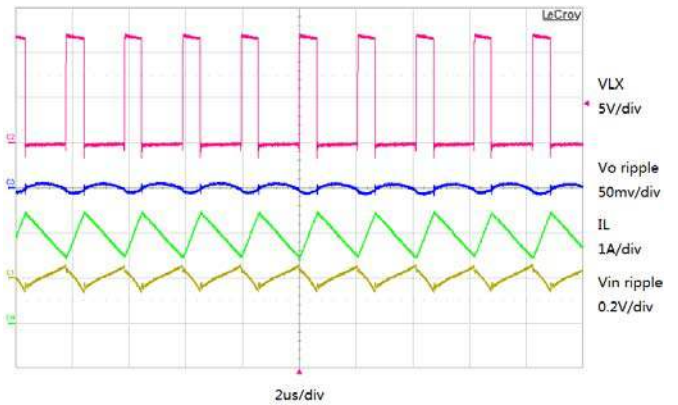

Figure 3. Full Load Operation

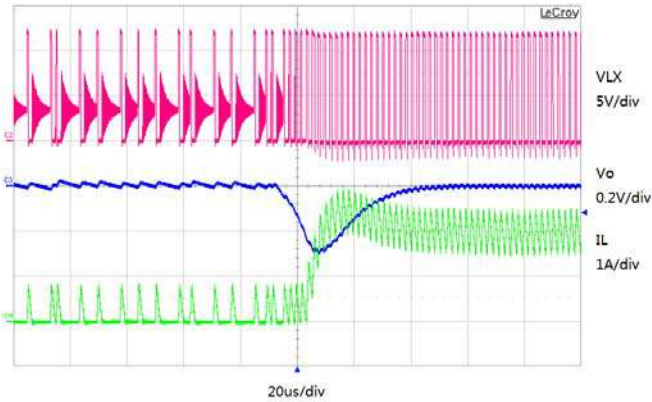

Figure 4. PEM to PWM Operation

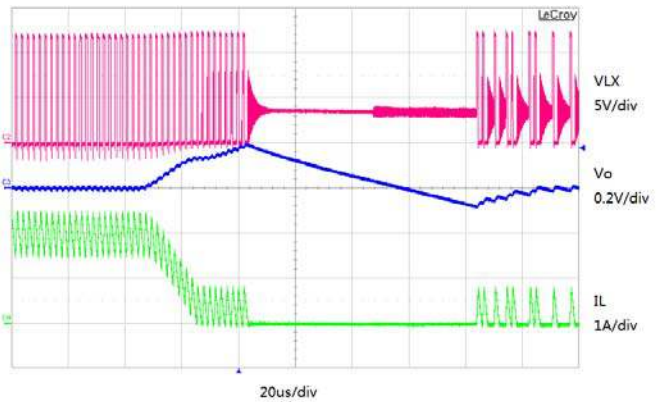

Figure 5. PWM to PEM Operation

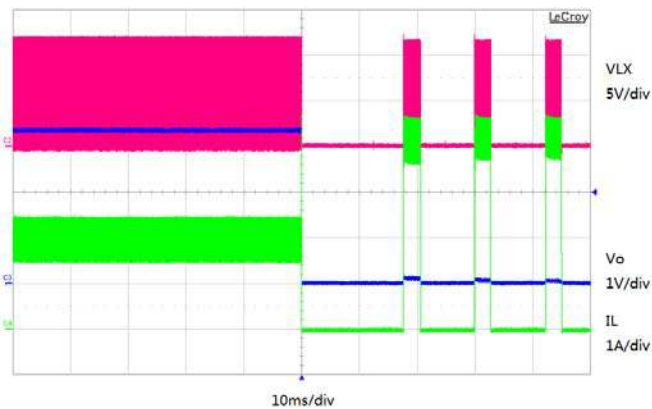

Figure 6. Short Circuit Protection

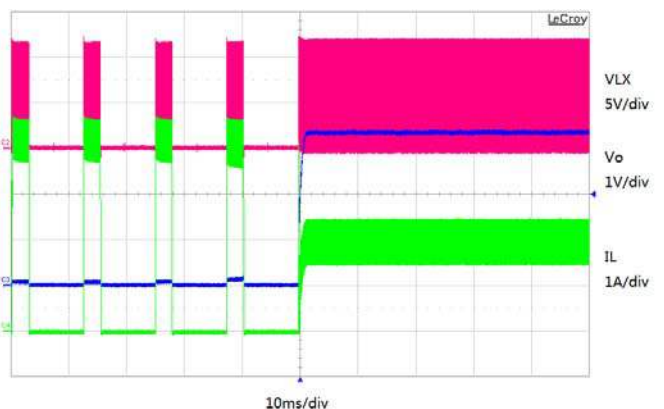

Figure 7. Short Circuit Recovery

### Typical Characteristics (continued)

Circuit of Typical Application.  $T_A = 25^\circ\text{C}$ ,  $V_{IN} = V_{EN} = 12\text{V}$ ,  $V_{OUT} = 3.3\text{V}$ , unless otherwise specified.

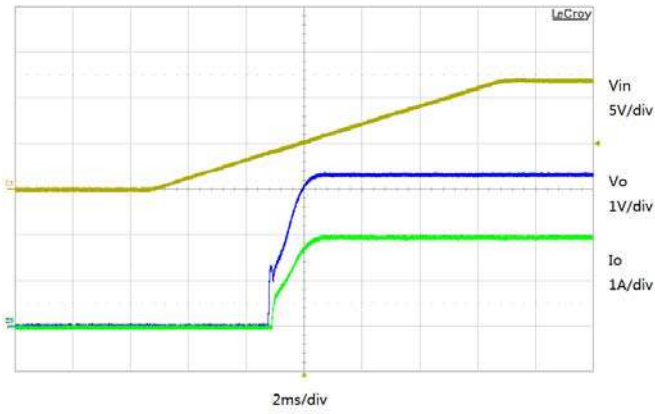

Figure 8. Full Load Startup

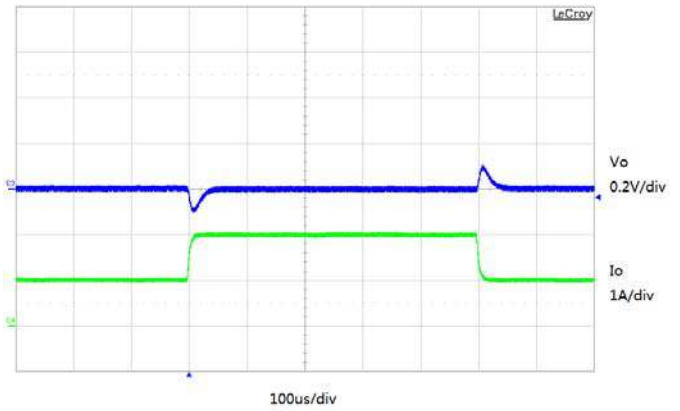

Figure 9. 50% to 100% Load Transient



## Detailed Description

The AOZ6622DI is a current-mode step down regulator with integrated high-side NMOS switch and low-side NMOS switch. It operates from a 4.5V to 18V input voltage range and supplies up to 2A of load current. Features include, enable control, Power-On Reset, input under voltage lockout, output over voltage protection, internal soft-start and thermal shut down.

The AOZ6622DI is available in 8-pin 3mm x 3mm DFN package.

### Enable and Soft Start

The AOZ6622DI has internal soft start feature to limit in-rush current and ensure the output voltage ramps up smoothly to regulation voltage. A soft start process begins when the input voltage rises to 4.1V and voltage on EN pin is HIGH. In soft start process, the output voltage is typically ramped to regulation voltage in 1.5ms. The 1.5ms soft start time is set internally.

The EN pin of the AOZ6622DI is active high. Connect the EN pin to VIN if enable function is not used. Pull it to ground will disable the AOZ6622DI. Do not leave it open. The voltage on EN pin must be above 2 V to enable the AOZ6622DI. When voltage on EN pin falls below 0.6V, the AOZ6622DI is disabled. The Figure 10 shows the EN input current vs. voltage.

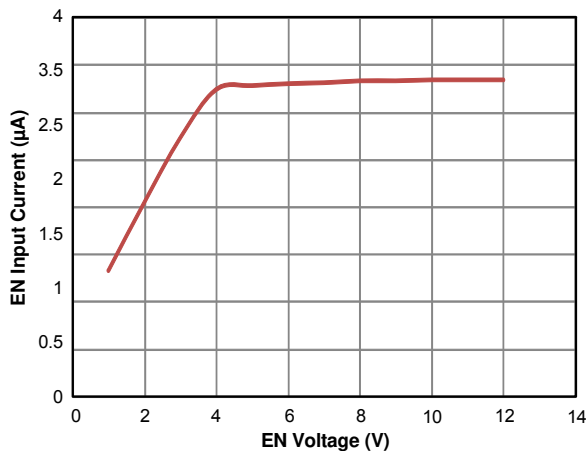

Figure 10. EN Input Current vs. EN Voltage

### Light Load and PWM Operation

Under low output current settings, the AOZ6622DI will operate with pulse energy mode to obtain high efficiency. In pulse energy mode, the PWM will not turn off until the inductor current reaches to 800 mA and the current signal exceeds the error voltage.

### Steady-State Operation

Under heavy load steady-state conditions, the converter operates in fixed frequency and Continuous-Conduction Mode (CCM).

The AOZ6622DI integrates an internal N-MOSFET as the high-side switch. Inductor current is sensed by amplifying the voltage drop across the drain to source of the high side power MOSFET. Output voltage is divided down by the external voltage divider at the FB pin. The difference of the FB pin voltage and reference is amplified by the internal transconductance error amplifier. The error voltage is compared against the current signal, which is sum of inductor current signal and ramp compensation signal, at PWM comparator input. If the current signal is less than the error voltage, the internal high-side switch is on. The inductor current flows from the input through the inductor to the output. When the current signal exceeds the error voltage, the high-side switch is off. The inductor current is freewheeling through the internal low-side N-MOSFET switch to output. The internal adaptive FET driver guarantees no turn on overlap of both high-side and low-side switch.

Comparing with regulators using freewheeling Schottky diodes, the AOZ6622DI uses freewheeling NMOSFET to realize synchronous rectification. It greatly improves the converter efficiency and reduces power loss in the low-side switch.

The AOZ6622DI uses a N-Channel MOSFET as the high-side switch. Since the NMOSFET requires a gate voltage higher than the input voltage, a boost capacitor is needed between LX pin and BST pin to drive the gate. The boost capacitor is charged while LX is low.

### Output Voltage Programming

Output voltage can be set by feeding back the output to the FB pin by using a resistor divider network. In the application circuit shown in Figure 1. The resistor divider network includes  $R_1$  and  $R_2$ . Usually, a design is started by picking a fixed  $R_2$  value and calculating the required  $R_1$  with equation below.

$$V_O = 0.8 \times \left( 1 + \frac{R_1}{R_2} \right)$$

Some standard value of R<sub>1</sub>, R<sub>2</sub> and most used output voltage values are listed in Table 1.

VO (V)	R1 (kΩ)	R2 (kΩ)
0.8	1.0	Open
1.2	4.99	10
1.5	10	11.5
1.8	12.7	10.2
2.5	21.5	10
3.3	31.1	10
5.0	52.3	10

Table 1.

Combination of R1 and R2 should be large enough to avoid drawing excessive current from the output, which will cause power loss.

### Protection Features

The AOZ6622DI has multiple protection features to prevent system circuit damage under abnormal conditions.

#### Over Current Protection (OCP)

The sensed inductor current signal is also used for over current protection. Since the AOZ6622DI employs peak current mode control, during over current conditions. The peak inductor current is automatically limited to cycle-by-cycle, and if output is shorted to GND, then the AOZ6622DI will shutdown and auto restart approximately every 25ms.

#### Power-On Reset (POR)

A power-on reset circuit monitors the VCC voltage. When the VCC voltage exceeds 4.1V, the converter starts operation. When VCC voltage falls below 3.7V, the converter will be shut down.

#### Thermal Protection

An internal temperature sensor monitors the junction temperature. It shuts down the internal control circuit and high side NMOS if the junction temperature exceeds 150°C. The regulator will restart automatically under the control of soft-start circuit when the junction temperature decreases to 100°C.

## Application Information

The basic AOZ6622DI application circuit is shown in Figure 1. Component selection is explained below.

### Input Capacitor

The input capacitor must be connected to the VIN pin and GND pin of the AOZ6622DI to maintain steady input voltage and filter out the pulsing input current. The voltage rating of input capacitor must be greater than maximum input voltage plus ripple voltage.

The input ripple voltage can be approximated by equation below:

$$\Delta V_{IN} = \frac{I_O}{f \times C_{IN}} \times \left(1 - \frac{V_O}{V_{IN}}\right) \times \frac{V_O}{V_{IN}}$$

Since the input current is discontinuous in a buck converter, the current stress on the input capacitor is another concern when selecting the capacitor. For a buck circuit, the RMS value of input capacitor current can be calculated by:

$$I_{CIN\_RMS} = I_O \times \sqrt{\frac{V_O}{V_{IN}} \left(1 - \frac{V_O}{V_{IN}}\right)}$$

if let *m* equal the conversion ratio:

$$\frac{V_O}{V_{IN}} = m$$

The relation between the input capacitor RMS current and voltage conversion ratio is calculated and shown in Figure 11 below. It can be seen that when V<sub>O</sub> is half of V<sub>IN</sub>, C<sub>IN</sub> it is under the worst current stress. The worst current stress on C<sub>IN</sub> is 0.5 x I<sub>O</sub>.

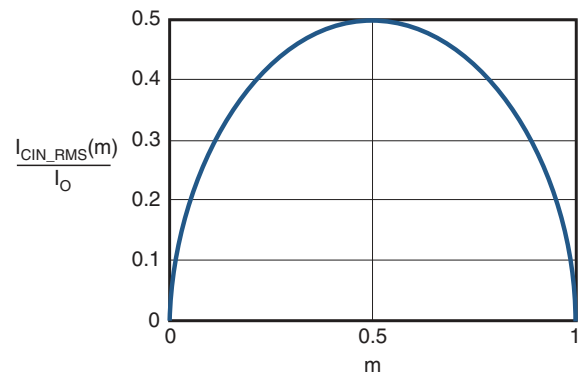

Figure 11. I<sub>CIN</sub> vs. Voltage Conversion Ratio

For reliable operation and best performance, the input capacitors must have current rating higher than  $I_{CIN-RMS}$  at worst operating conditions. Ceramic capacitors are preferred for input capacitors because of their low ESR and high ripple current rating. Depending on the application circuits, other low ESR tantalum capacitor or aluminum electrolytic capacitor may also be used. When selecting ceramic capacitors, X5R or X7R type dielectric ceramic capacitors are preferred for their better temperature and voltage characteristics. Note that the ripple current rating from capacitor manufactures is based on certain amount of life time. Further de-rating may be necessary for practical design requirement.

### Inductor

The inductor is used to supply constant current to output when it is driven by a switching voltage. For given input and output voltage, inductance and switching frequency together decide the inductor ripple current, which is:

$$\Delta I_L = \frac{V_O}{f \times L} \times \left(1 - \frac{V_O}{V_{IN}}\right)$$

The peak inductor current is:

$$I_{Lpeak} = I_O + \frac{\Delta I_L}{2}$$

High inductance gives low inductor ripple current but requires a larger size inductor to avoid saturation. Low ripple current reduces inductor core losses. It also reduces RMS current through inductor and switches, which results in less conduction loss. Usually, peak to peak ripple current on inductor is designed to be 20% to 40% of output current.

When selecting the inductor, make sure it is able to handle the peak current without saturation even at the highest operating temperature.

The inductor takes the highest current in a buck circuit. The conduction loss on the inductor needs to be checked for thermal and efficiency requirements.

Surface mount inductors in different shapes and styles are available from Coilcraft, Elytone and Murata. Shielded inductors are small and radiate less EMI noise, but they do cost more than unshielded inductors. The choice depends on EMI requirement, price and size.

### Output Capacitor

The output capacitor is selected based on the DC output voltage rating, output ripple voltage specification and ripple current rating.

The selected output capacitor must have a higher rated voltage specification than the maximum desired output voltage including ripple. De-rating needs to be considered for long term reliability.

Output ripple voltage specification is another important factor for selecting the output capacitor. In a buck converter circuit, output ripple voltage is determined by inductor value, switching frequency, output capacitor value and ESR. It can be calculated by the equation below:

$$\Delta V_O = \Delta I_L \times \left(ESR_{CO} + \frac{1}{8 \times f \times C_O}\right)$$

where,

$C_O$  is output capacitor value and  $ESR_{CO}$  is the Equivalent Series Resistor of output capacitor. When a low ESR ceramic capacitor is used as output capacitor, the impedance of the capacitor at the switching frequency dominates. Output ripple is mainly caused by capacitor value and inductor ripple current. The output ripple voltage calculation can be simplified to:

$$\Delta V_O = \Delta I_L \times \frac{1}{8 \times f \times C_O}$$

If the impedance of ESR at switching frequency dominates, the output ripple voltage is mainly decided by capacitor ESR and inductor ripple current. The output ripple voltage calculation can be further simplified to:

$$\Delta V_O = \Delta I_L \times ESR_{CO}$$

For lower output ripple voltage across the entire operating temperature range, X5R or X7R dielectric type of ceramic, or other low ESR tantalum are recommended to be used as output capacitors.

In a buck converter, output capacitor current is continuous. The RMS current of output capacitor is decided by the peak to peak inductor ripple current. It can be calculated by:

$$I_{CO\_RMS} = \frac{\Delta I_L}{\sqrt{12}}$$

Usually, the ripple current rating of the output capacitor is a smaller issue because of the low current stress. When the buck inductor is selected to be very small and inductor ripple current is high, the output capacitor could be overstressed.

## Thermal Management and Layout Consideration

In the AOZ6622DI buck regulator circuit, high pulsing current flows through two circuit loops. The first loop starts from the input capacitors, to the VIN pin, to the LX pad, to the filter inductor, to the output capacitor and load, and then return to the input capacitor through ground. Current flows in the first loop when the high side switch is on. The second loop starts from inductor, to the output capacitors and load, to the low side NMOSFET. Current flows in the second loop when the low side NMOSFET is on.

In PCB layout, minimizing the two loops area reduces the noise of this circuit and improves efficiency. A ground plane is strongly recommended to connect input capacitor, output capacitor, and GND pin of the AOZ6622DI.

In the AOZ6622DI buck regulator circuit, the major power dissipating components are the AOZ6622DI and output inductor. The total power dissipation of the converter circuit can be measured by input power minus output power.

$$P_{total\_loss} = V_{IN} \times I_{IN} - V_O \times I_O$$

The power dissipation of inductor can be approximately calculated by output current and DCR of inductor.

$$P_{inductor\_loss} = I_O^2 \times R_{inductor} \times 1.1$$

The actual junction temperature can be calculated with power dissipation in the AOZ6622DI and thermal impedance from junction to ambient.

$$T_{junction} = (P_{total\_loss} - P_{inductor\_loss}) \times \Theta_{JA}$$

The maximum junction temperature of AOZ6622DI is 150°C, which limits the maximum load current capability.

The thermal performance of the AOZ6622DI is strongly affected by the PCB layout. Extra care should be taken by users during design process to ensure that the IC will operate under the recommended environmental conditions.

The AOZ6622DI is an exposed pad DFN3X3 package. Several layout tips are listed below for the best electric and thermal performance.

1. The exposed thermal pad has to connect to ground by PCB externally. Connect a large copper plane to exposed thermal pad to help thermal dissipation.
2. Do not use thermal relief connection to the VIN and the GND pin. Pour a maximized copper area to the GND pin and the VIN pin to help thermal dissipation.
3. Input capacitor should be connected to the VIN pin and the GND pin as close as possible.
4. Make the current trace from LX pins to L to Co to the GND as short as possible.
5. Pour copper plane on all unused board area and connect it to stable DC nodes, like VIN, GND or VOUT.
6. Keep sensitive signal trace far away from the LX pad.

Package Dimensions, DFN 3x3B, 8 Lead EP1\_P

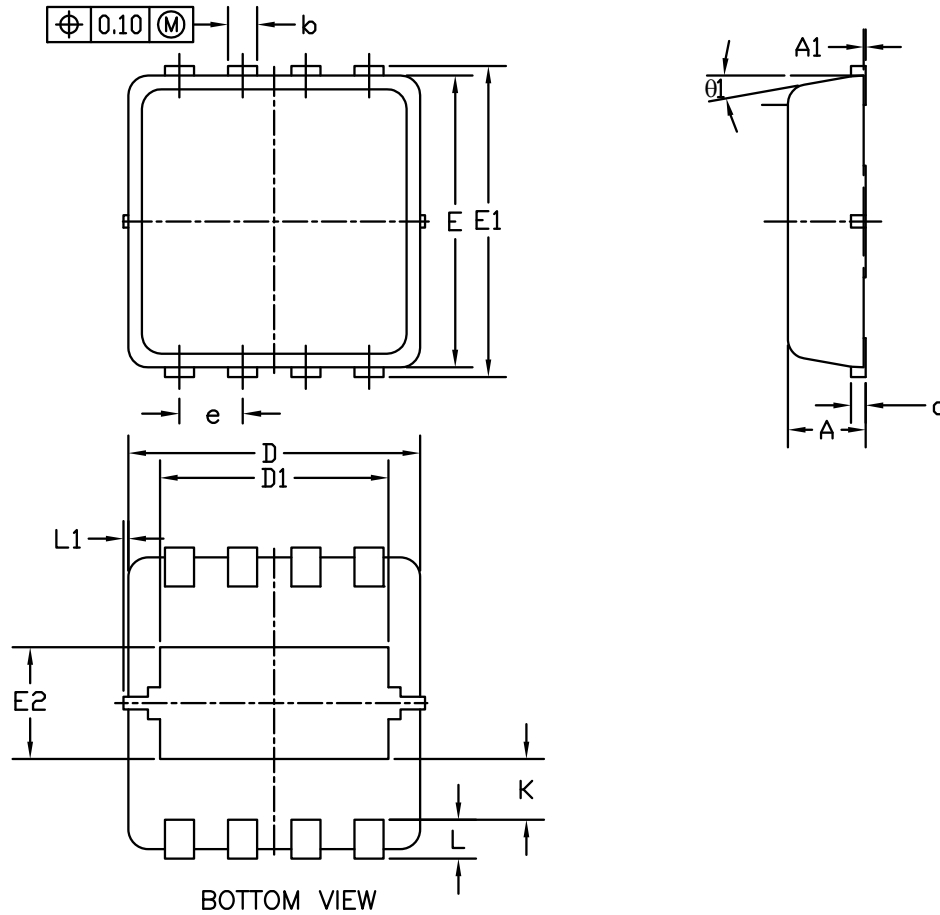

RECOMMENDED LAND PATTERN

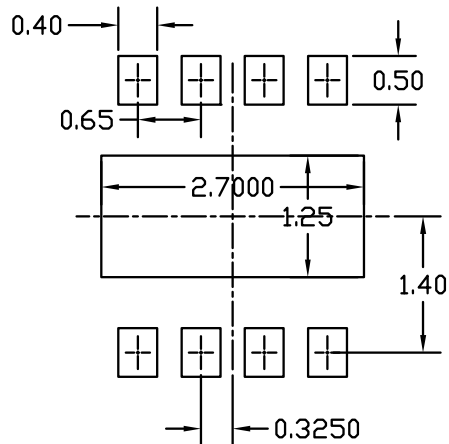

SYMBOLS	DIMENSIONS IN MILLIMETERS			DIMENSIONS IN INCHES		
	MIN	NOM	MAX	MIN	NOM	MAX
A	0.70	0.80	0.90	0.028	0.031	0.035
A1	0.00	---	0.05	0.000	---	0.002
b	0.24	0.30	0.35	0.009	0.012	0.014
c	0.10	0.15	0.25	0.004	0.006	0.010
D	2.90	3.00	3.10	0.114	0.118	0.122
D1	2.15	2.35	2.55	0.085	0.093	0.100
E	2.90	3.00	3.10	0.114	0.118	0.122
E1	3.05	3.20	3.35	0.120	0.126	0.132
E2	1.10	1.15	1.20	0.043	0.045	0.047
e	0.60	0.65	0.70	0.024	0.026	0.028
K	0.575	0.625	0.675	0.023	0.025	0.027
L	0.30	0.40	0.50	0.012	0.016	0.020
L1	0	---	0.10	0	---	0.004
θ1	0	10	12	0	10	12

NOTE

1. PACKAGE BODY SIZES EXCLUDE MOLD FLASH AND GATE BURRS.  
MOLD FLASH AT THE NON-LEAD SIDES SHOULD BE LESS THAN 6 MILS EACH.
2. CONTROLLING DIMENSION IS MILLIMETER.  
CONVERTED INCH DIMENSIONS ARE NOT NECESSARILY EXACT.

### Tape and Reel Dimensions, DFN 3x3, EP

#### Carrier Tape

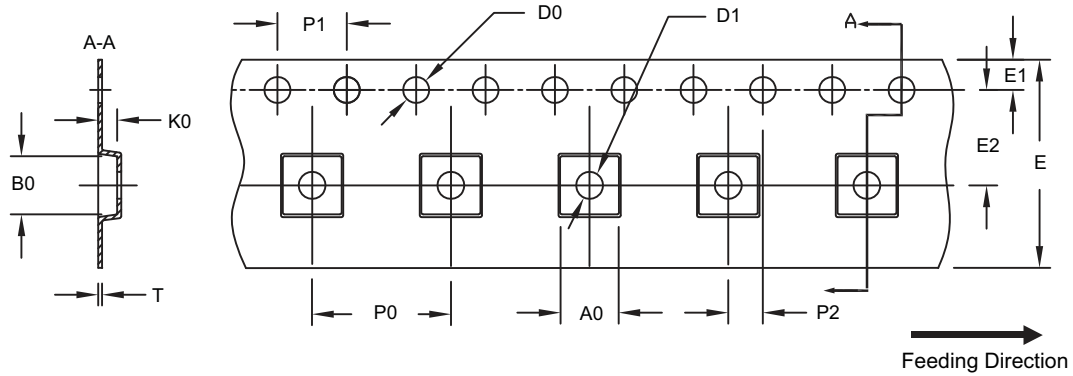

UNIT: mm

Package	A0	B0	K0	D0	D1	E	E1	E2	P0	P1	P2	T
DFN 3x3 EP	3.40 ±0.10	3.35 ±0.10	1.10 ±0.10	1.50 +0.10/-0	1.50 +0.10/-0	12.00 ±0.30	1.75 ±0.10	5.50 ±0.05	8.00 ±0.10	4.00 ±0.10	2.00 ±0.05	0.30 ±0.05

#### Reel

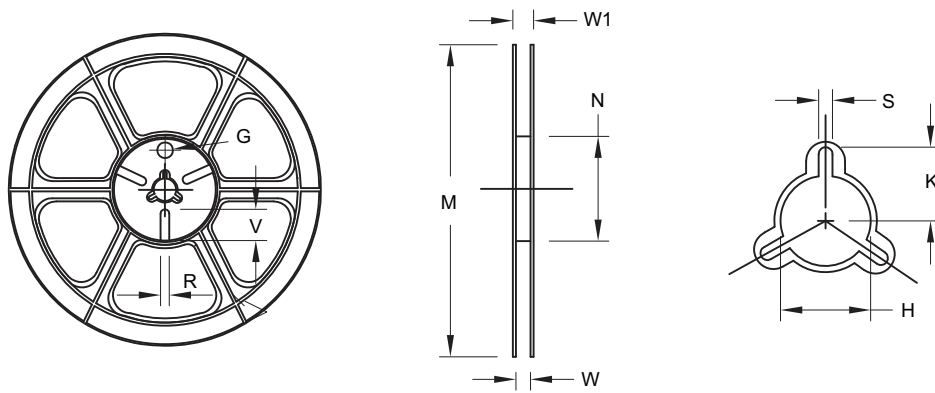

UNIT: mm

Tape Size	Reel Size	M	N	W	W1	H	K	S	G	R	V
12mm	ø330	ø330.0 ±0.50	ø97.0 ±1.0	13.0 ±0.30	17.4 ±1.0	ø13.0 +0.5/-0.2	10.6	2.0 ±0.5	—	—	—

#### Leader/Trailer and Orientation

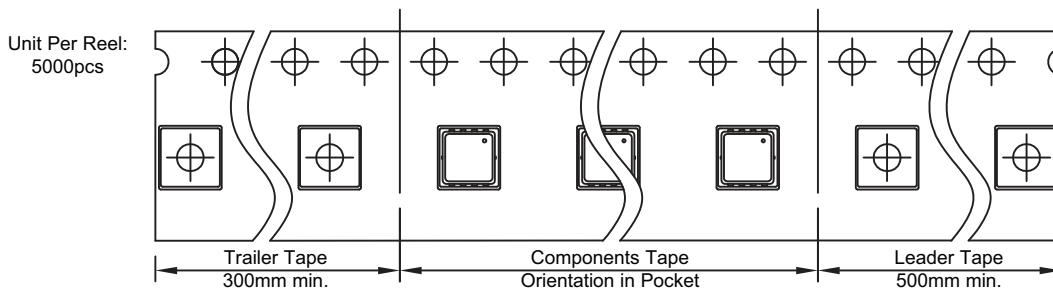

## Part Marking

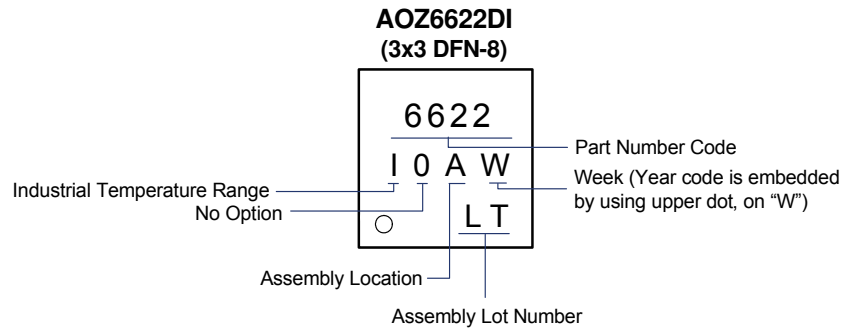

## LEGAL DISCLAIMER

Applications or uses as critical components in life support devices or systems are not authorized. AOS does not assume any liability arising out of such applications or uses of its products. AOS reserves the right to make changes to product specifications without notice. It is the responsibility of the customer to evaluate suitability of the product for their intended application. Customer shall comply with applicable legal requirements, including all applicable export control rules, regulations and limitations.

AOS' products are provided subject to AOS' terms and conditions of sale which are set forth at:

[http://www.aosmd.com/terms\\_and\\_conditions\\_of\\_sale](http://www.aosmd.com/terms_and_conditions_of_sale)

## LIFE SUPPORT POLICY

ALPHA AND OMEGA SEMICONDUCTOR PRODUCTS ARE NOT AUTHORIZED FOR USE AS CRITICAL COMPONENTS IN LIFE SUPPORT DEVICES OR SYSTEMS.

As used herein:

1. Life support devices or systems are devices or systems which, (a) are intended for surgical implant into the body or (b) support or sustain life, and (c) whose failure to perform when properly used in accordance with instructions for use provided in the labeling, can be reasonably expected to result in a significant injury of the user.

2. A critical component in any component of a life support, device, or system whose failure to perform can be reasonably expected to cause the failure of the life support device or system, or to affect its safety or effectiveness.