

P	LTR	DESCRIPTION	DATE	DWN	APVD
	C	REVISED PER 0G3B-0119-01	21AUG2001	EZ	DB
	CI	PART STATUS UPDATED	21OCT2021	SCB	SS

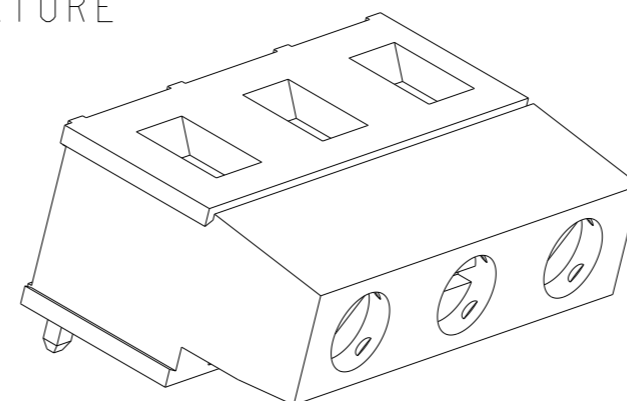
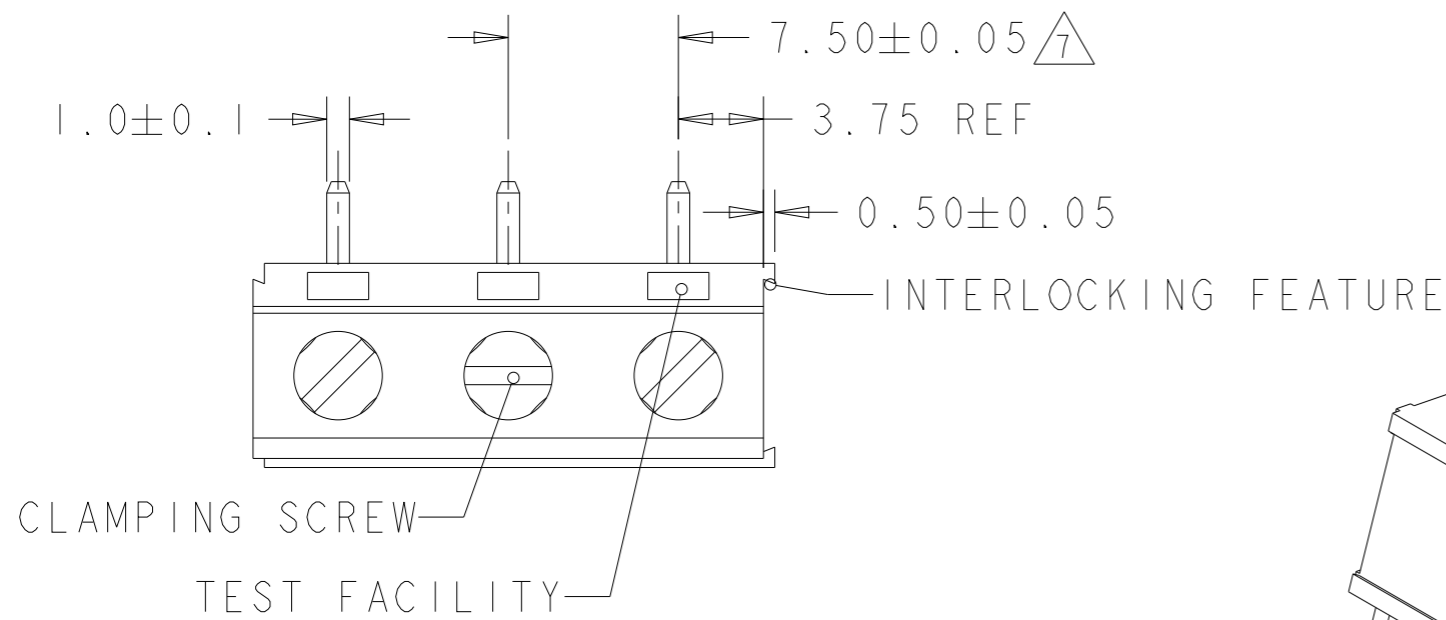

282854-3 AS SHOWN

1 MATERIALS AND FINISH
 HOUSING: PA 6-6, UL 94-V0, COLOR GREEN.
 CLAMP: BRASS, NICKEL PLATED.
 TERMINAL: BRASS, TIN PLATED.
 CLAMPING SCREW: M3, BRASS, NICKEL PLATED.

2 SUITABLE FOR 1,6-2,4mm PC BOARD THICKNESS.

3 END-TO-END STACKABLE W/INTERLOCK WITHOUT LOSS OF CENTERLINE SPACING.

4 WIRE SIZE RANGE
 SOLID WIRE: 0,03-2,5mm² (13AWG).
 STRANDED WIRE: 0,03-1,5mm² (15AWG).

5 RECOGNIZED UNDER THE COMPONENT PROGRAM OF UNDERWRITERS LABORATORIES INC. FILE N° E60677.

6 IMQ CERTIFICATE WITH SURVEILLANCE IN CONFORMITY WITH IEC 998-1/998-2-1.

7 NOT CUMULATIVE TOLERANCE.

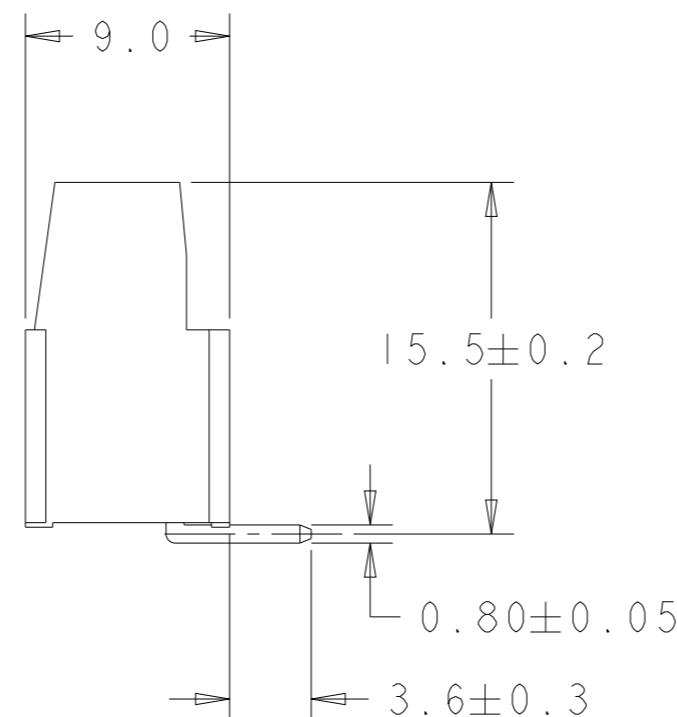
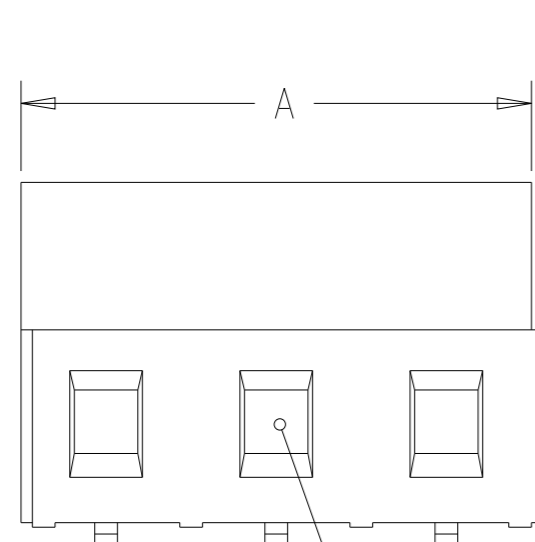

	OBSOLETE	30	4	282854-4
		22.5	3	282854-3
	OBSOLETE	15	2	282854-2

RECOMMENDED PCB LAYOUT

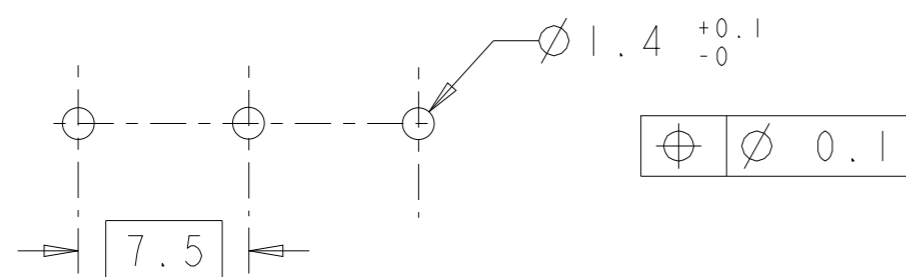

THIS DRAWING IS A CONTROLLED DOCUMENT.		DWN E. ZANOLINI 21AUG2001	TE Connectivity	
DIMENSIONS: mm		CHK D. BIEVENOUR 21AUG2001		
TOLERANCES UNLESS OTHERWISE SPECIFIED:		APVD D. BIEVENOUR 21AUG2001	NAME TERMINAL BLOCK PCB MOUNT TOP ENTRY WIRE, STACKING W/ INTERLOCK, 7.5mm PITCH	
0 PLC ±-		PRODUCT SPEC 108-20166	SIZE A300779	
1 PLC ±.3		APPLICATION SPEC 114-20079	CAGE CODE C-282854	
2 PLC ±.25		WEIGHT -	DRAWING NO -	
3 PLC ±-		CUSTOMER DRAWING	RESTRICTED TO -	
4 PLC ±-			SCALE 3:1	SHEET 1 OF 1
ANGLES ±2				
FINISH				