

## MAX22201/MAX22202/ MAX22207

## 36V, 3.5A Brushed Motor Driver with Integrated Current Sense

### General Description

The MAX22201/MAX22202/MAX22207 integrate one 36V, 3.5A peak full bridge capable of driving one brushed DC motor. The full bridge features very low impedance FETs with a typical  $R_{ON}$  (high side + low side) of  $0.3\Omega$  resulting in high driving efficiency. The peak current rating of 3.5A is limited by the overcurrent protection threshold (OCP). The peak current is defined as the maximum current the driver can provide for short transients. The maximum RMS current is 2A and is typically limited by thermal considerations. The  $2A_{RMS}$  capability refers to a standard JEDEC 4-layer board at  $25^{\circ}\text{C}$  ambient temperature. The real operating maximum current depends on the application thermal characteristic (PCB ground planes, heat sinks, ventilation, etc.).

The MAX22201/MAX22202/MAX22207 feature a non-dissipative and accurate integrated current sensing (ICS) and an embedded internal current drive regulation (CDR) circuit to monitor the current through a motor coil and limit the peak output current. When the motor current exceeds the current limit threshold, the full bridge enters a decay mode for a fixed off time ( $t_{OFF}$ ). For brushed motor drive applications, the current drive regulation guarantees safe and reliable operation of the driver under normal conditions or during motor startup and stall conditions, and also reduces system power and supply bypassing requirements. A scaled copy of the internally sensed current is output to an external pin (ISEN). For more information on these features, refer to the [Detailed Description](#).

All versions feature overcurrent protection (OCP), thermal shutdown (TSD), and undervoltage lockout (UVLO). An open-drain active-low fault indication pin ( $\overline{\text{FAULT}}$ ) is activated every time a fault condition is detected.

The device is packaged into a tiny TDFN12 3mm x 3mm package. The small package footprint, the extremely high efficiency and the integrated accurate current sensing make the MAX22201/MAX22202/MAX22207 an excellent choice for space- and power-sensitive applications.

### Applications

- Brushed DC Motor Drive
- Stepper Motor Drive (One Phase Only)
- Latched Valves and Solenoids

### Benefits and Features

- One Full H-Bridge with +36V Voltage Rating
- Total  $R_{DS(ON)}$  (High Side + Low Side):  $300\text{m}\Omega$  (typ) ( $T_A = +25^{\circ}\text{C}$ )
- Current Ratings ( $+25^{\circ}\text{C}$  typ)
  - $I_{PEAK} = 3.5\text{A}$
  - $I_{RMS} = 2\text{A}$
- Configurable Current Drive Regulation (CDR) for Limiting Stall and Inrush Current
  - Configurable Off Time ( $t_{OFF}$ ) for CDR (MAX22201 only)
- Lossless Integrated Current Sensing (ICS) Eliminates External Bulky Resistors and Saves Power
- Current Sense Output (CSO) Function: A Replica of the Internally Sensed Current is Output on the ISEN Pin
- Current Drive Regulation Monitor (CDROUT) (MAX22207 only)
- Fault Indicator pin ( $\overline{\text{FAULT}}$ )
- Fully Integrated Charge Pump
- Protections
  - Overcurrent Protection for Each Individual Channel (OCP)
  - Undervoltage Lockout (UVLO)
  - Thermal Shutdown (TSD)  $T = +165^{\circ}\text{C}$
  - ESD Protection 8kV HBM (OUT1 and OUT2 Pins)
- Ultra-Small Package TDFN12 3mm x 3mm

Simplified Block Diagram

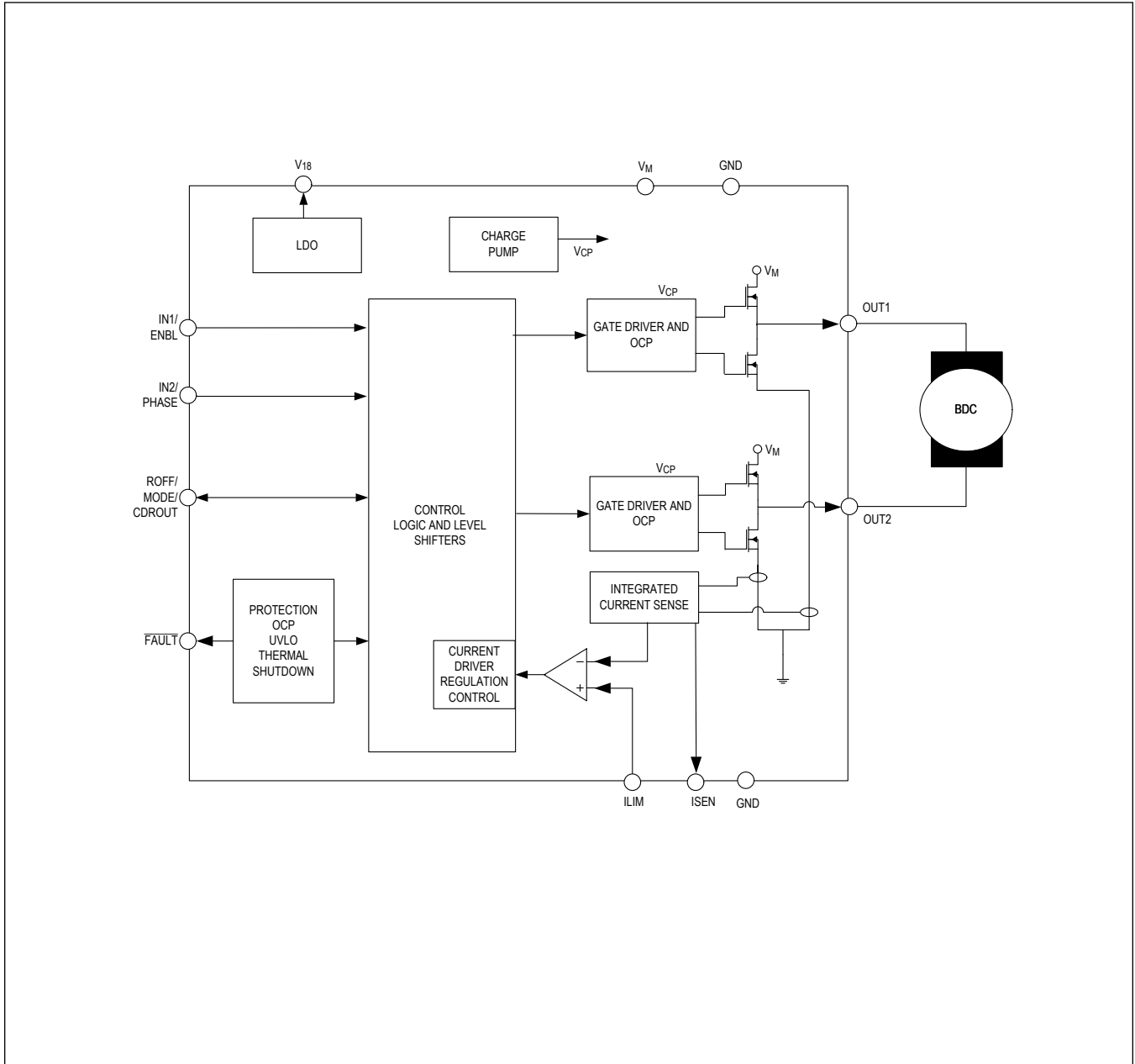

## Absolute Maximum Ratings

$V_M$ to GND .....	-0.3V to +40V	ENBL, PHASE to GND (MAX22202 only).....	-0.3V to +6V
$V_{18}$ to GND.....	-0.3V to +2.2V	MODE to GND (MAX22202 only) .....	-0.3V to +6V
OUT to GND.....	-0.3V to $V_M + 0.3V$	GNDP to GND.....	-0.3V to +0.3V
FAULT to GND .....	-0.3V to +6V	Continuous Power Dissipation TDFN (Multilayer Board) ( $T_A = +70^\circ\text{C}$ , derate 24.4mW/ $^\circ\text{C}$ above $+70^\circ\text{C}$ .).....	1951.20mW
ILIM to GND.....	-0.3V to +2.2V	Junction Temperature (Note 1).....	+150 $^\circ\text{C}$
ISEN to GND.....	-0.3V to +2.2V	Storage Temperature Range .....	-40 $^\circ\text{C}$ to +150 $^\circ\text{C}$
CDROUT to GND (MAX22207 only) .....	-0.3V to +6V	Soldering Temperature (reflow) .....	+260 $^\circ\text{C}$
ROFF to GND (MAX22201 only).....	-0.3V to +2.2V	Operating Temperature Range .....	-40 $^\circ\text{C}$ to +125 $^\circ\text{C}$
IN1, IN2 to GND (MAX22201 only) .....	-0.3V to +6V		

**Note 1:** The maximum operating junction temperature must not be exceeded as this could affect the reliability of the device and eventually cause damage. The embedded thermal protection does not guarantee reliability under extreme operating conditions.

Stresses beyond those listed under "Absolute Maximum Ratings" may cause permanent damage to the device. These are stress ratings only, and functional operation of the device at these or any other conditions beyond those indicated in the operational sections of the specifications is not implied. Exposure to absolute maximum rating conditions for extended periods may affect device reliability.

## Package Information

### TDFN12 3x3mm

Package Code	TD1233+1C
Outline Number	<a href="#">21-0664</a>
Land Pattern Number	<a href="#">90-0397</a>
<b>THERMAL RESISTANCE, SINGLE-LAYER BOARD</b>	
Junction-to-Ambient ( $\theta_{JA}$ )	63 $^\circ\text{C}/\text{W}$
Junction-to-Case Thermal Resistance ( $\theta_{JC}$ )	8.5 $^\circ\text{C}/\text{W}$
<b>THERMAL RESISTANCE, FOUR-LAYER BOARD</b>	
Junction-to-Ambient ( $\theta_{JA}$ )	41 $^\circ\text{C}/\text{W}$
Junction-to-Case Thermal Resistance ( $\theta_{JC}$ )	8.5 $^\circ\text{C}/\text{W}$

For the latest package outline information and land patterns (footprints), go to [www.maximintegrated.com/packages](http://www.maximintegrated.com/packages). Note that a "+", "#", or "-" in the package code indicates RoHS status only. Package drawings may show a different suffix character, but the drawing pertains to the package regardless of RoHS status.

Package thermal resistances were obtained using the method described in JEDEC specification JESD51-7, using a four-layer board. For detailed information on package thermal considerations, refer to [www.maximintegrated.com/thermal-tutorial](http://www.maximintegrated.com/thermal-tutorial).

## Electrical Characteristics

( $V_M = +3V$  to  $+36V$ ,  $T_A = -40^\circ\text{C}$  to  $+125^\circ\text{C}$ , Limits are 100% tested at  $T_A = +25^\circ\text{C}$ . Limits over the operating temperature range are guaranteed by design and characterization. Specifications marked "GBD" are guaranteed by design and not production tested. Typical values are at  $V_M = +24V$  and  $T_A = +25^\circ\text{C}$ , unless otherwise noted. 25k $\Omega$  connected to ILIM)

PARAMETER	SYMBOL	CONDITIONS	MIN	TYP	MAX	UNITS
<b>POWER SUPPLY</b>						
Supply-Voltage Range	$V_M$		3		36	V
Disable Current Consumption	$I_{VM}$	$V_M = +24V$ , in Sleep Mode		3.5	6.5	$\mu\text{A}$
Quiescent-Current Consumption	$I_{VM}$	$V_M = +24V$ , not in Sleep Mode			4	mA

### Electrical Characteristics (continued)

( $V_M = +3V$  to  $+36V$ ,  $T_A = -40^\circ C$  to  $+125^\circ C$ , Limits are 100% tested at  $T_A = +25^\circ C$ . Limits over the operating temperature range are guaranteed by design and characterization. Specifications marked "GBD" are guaranteed by design and not production tested. Typical values are at  $V_M = +24V$  and  $T_A = +25^\circ C$ , unless otherwise noted. 25k $\Omega$  connected to ILIM)

PARAMETER	SYMBOL	CONDITIONS	MIN	TYP	MAX	UNITS	
$V_M$ Undervoltage Lockout Threshold	UVLO		2.67		3	V	
$V_M$ Undervoltage Lockout Threshold Hysteresis	UVLO_HYST			110		mV	
<b>LOGIC INPUTS/OUTPUTS</b>							
Input-Voltage Level High	$V_{IH}$		2			V	
Input-Voltage Level Low	$V_{IL}$				0.8	V	
Pulldown Resistor	$R_{PD}$			100		k $\Omega$	
Input Hysteresis	$V_{HYS}$			360		mV	
Open-Drain Output Pins Voltage Level Low	$V_{OL}$	Pullup current = 1mA		0.03	0.1	V	
<b>DRIVER OUTPUT SPECIFICATIONS</b>							
Output On-Resistance Low Side	$R_{ON(LS)}$	$I_{LOAD} = 200mA$		0.15	0.25	$\Omega$	
Output On-Resistance High Side	$R_{ON(HS)}$	$I_{LOAD} = 200mA$		0.15	0.25	$\Omega$	
Output Leakage	$I_{LEAK}$	Driver off	-5		+5	$\mu A$	
OUT1, OUT2 Slew Rate	SR	GBD		200		V/ $\mu s$	
<b>CURRENT REGULATION</b>							
$R_{ILIM}$ Resistor Range	$R_{ILIM}$	Resistor connected between ILIM and GND	18		250	k $\Omega$	
Current-Drive Regulation Constant	$K_{ILIM}$	See Equation 1		50		kV	
ILIM Pin Voltage	$V_{ILIM}$	Voltage at pin ILIM. $R_{ILIM} = 25k\Omega$		1.0		V	
Current Drive Regulation Accuracy	DKLIM <sub>1</sub>	$T_A = +25^\circ C, V_M = +6V$ to $+24V$		$I_{OUT}$ greater than 0.8A	-5	+5	%
	DKLIM <sub>2</sub>				$I_{OUT}$ from 0.2A to 0.8A	-15	
<b>CURRENT REGULATION / t<sub>OFF</sub> SETTING (ROFF) MAX22201 ONLY</b>							
t <sub>OFF</sub> Time when the ROFF Pin is Unconnected	t <sub>OFF</sub>	ROFF pin unconnected	17	20	23	$\mu s$	
t <sub>OFF</sub> Programming Range	t <sub>OFFR</sub>	Resistor connected from ROFF to GND from 30.1k $\Omega$ to 240k $\Omega$		10 to 80		$\mu s$	
<b>CURRENT SENSE MONITOR</b>							
$V_{ISEN}$ Voltage Range	$V_{ISEN}$	Voltage range at the ISEN pin	0		1.2	V	
Current Monitor Scaling Factor	$K_{ISEN}$	See Equation 3		5000		A/A	
Current Monitor Accuracy	DKISEN <sub>1</sub>	$T_A = +25^\circ C, V_M = +6V$ to $+24V$		$I_{OUT} = 0.8A$ to 2A	-3	+3	%
	DKISEN <sub>2</sub>				$I_{OUT} = 0.2A$ to 0.8A	-5	

### Electrical Characteristics (continued)

( $V_M = +3V$  to  $+36V$ ,  $T_A = -40^\circ C$  to  $+125^\circ C$ , Limits are 100% tested at  $T_A = +25^\circ C$ . Limits over the operating temperature range are guaranteed by design and characterization. Specifications marked "GBD" are guaranteed by design and not production tested. Typical values are at  $V_M = +24V$  and  $T_A = +25^\circ C$ , unless otherwise noted. 25k $\Omega$  connected to ILIM)

PARAMETER	SYMBOL	CONDITIONS	MIN	TYP	MAX	UNITS
Current Sense Output -3dB Small Signal Bandwidth	BW	GBD		1		MHz
<b>PROTECTION CIRCUITS</b>						
Overcurrent-Protection Threshold	OCP		3.5	5		A
Overcurrent-Protection Blanking Time	$t_{OCP}$		1.24	2		$\mu s$
Auto-Retry OCP Time	$t_{RETRY}$			2		ms
Thermal Protection Shutdown Threshold Temperature	TSD			165		$^\circ C$
Thermal Protection Shutdown Hysteresis	THYS			30		$^\circ C$
<b>FUNCTIONAL TIMINGS</b>						
PWM Frequency	$f_{SW}$	PWM input frequency, GBD			100	kHz
Minimum $t_{ON}$ Time	$t_{ONMIN}$		2	2.5		$\mu s$
Dead Time	$t_{DEAD}$	Dead zone to prevent current shoot through from $V_M$		150		ns
Time to Sleep (MAX22201, MAX22207)	$t_{SLEEP}$	From IN1 and IN2 low to device disabled	1.5	2.2	3.5	ms
Turn-On Time (MAX22201, MAX22207)	$t_{ON}$	$V_M > V_{UVLO}$ with IN1, IN2 High (Brake)		300	400	$\mu s$
Time to Sleep (MAX22202)	$t_{SLEEP}$	From MODE low to device disabled	1.5	2.2	3.5	ms
Turn-On Time (MAX22202)	$t_{ON}$	$V_M > V_{UVLO}$ with MODE high		300	400	$\mu s$
<b>LDO (<math>V_{18}</math>)</b>						
$V_{18}$ Output-Voltage Range	$V_{18}$	No external load	1.728	1.8	1.872	V
$V_{18}$ Current Limit	$I_{V18(LIM)}$		20			mA
$V_{18}$ UVLO Rising	UVLOV18R	$V_{18}$ rising	1.61	1.65	1.69	V
$V_{18}$ UVLO Hysteresis	UVLOV18H			70		mV

### Typical Operating Characteristics

( $V_M = +3V$  to  $+36V$ ,  $T_A = 25^\circ C$  unless otherwise noted.)

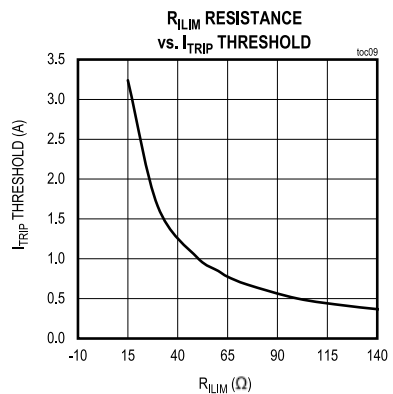
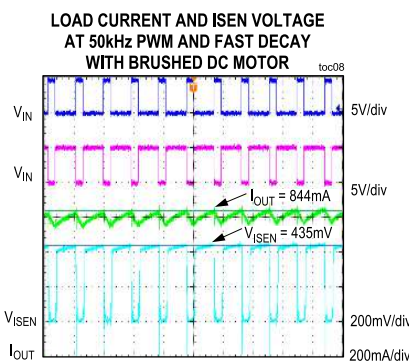
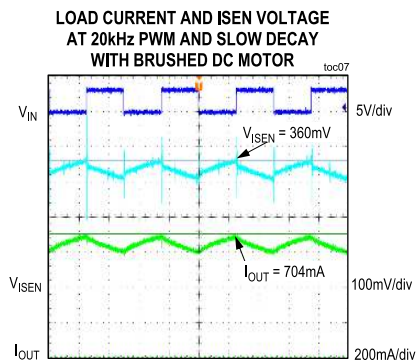
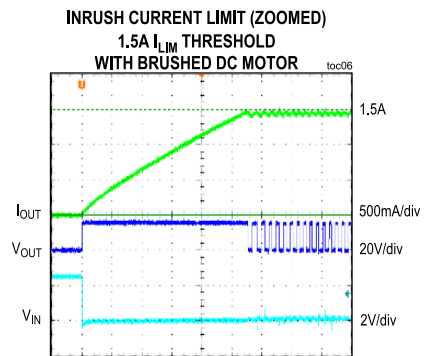
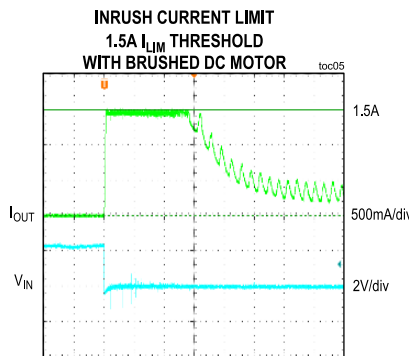
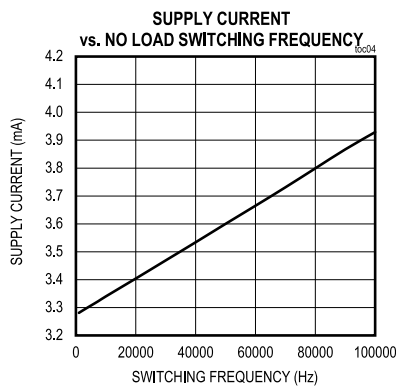
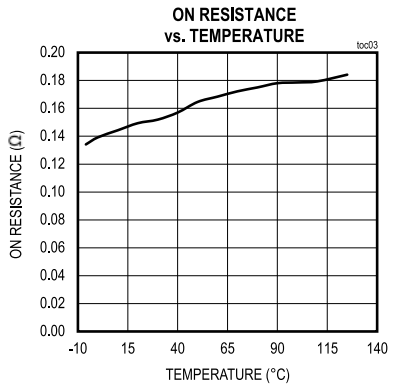
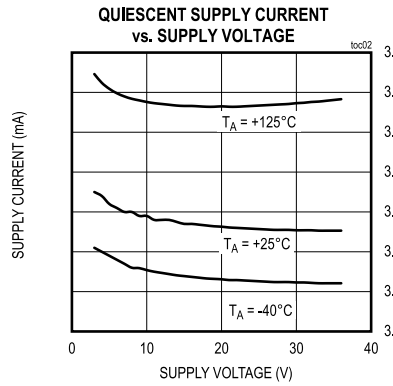
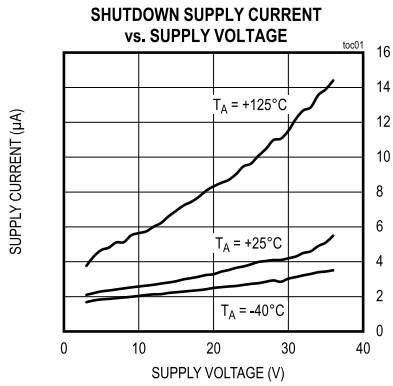

## Pin Configurations

### MAX22201

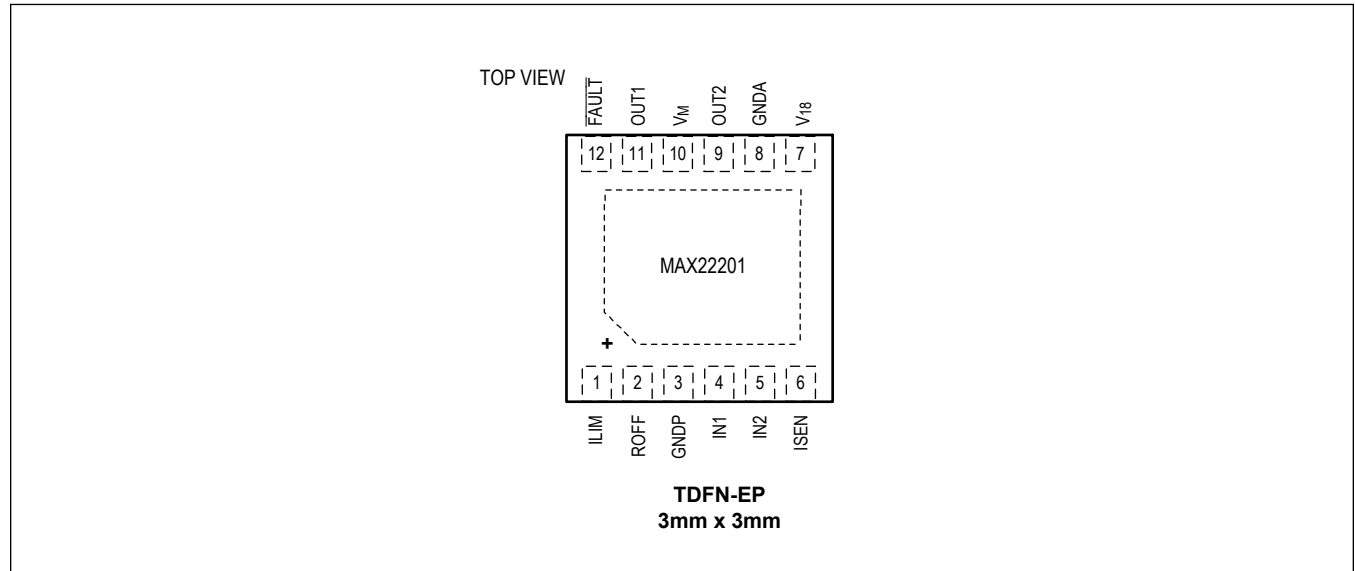

### MAX22202

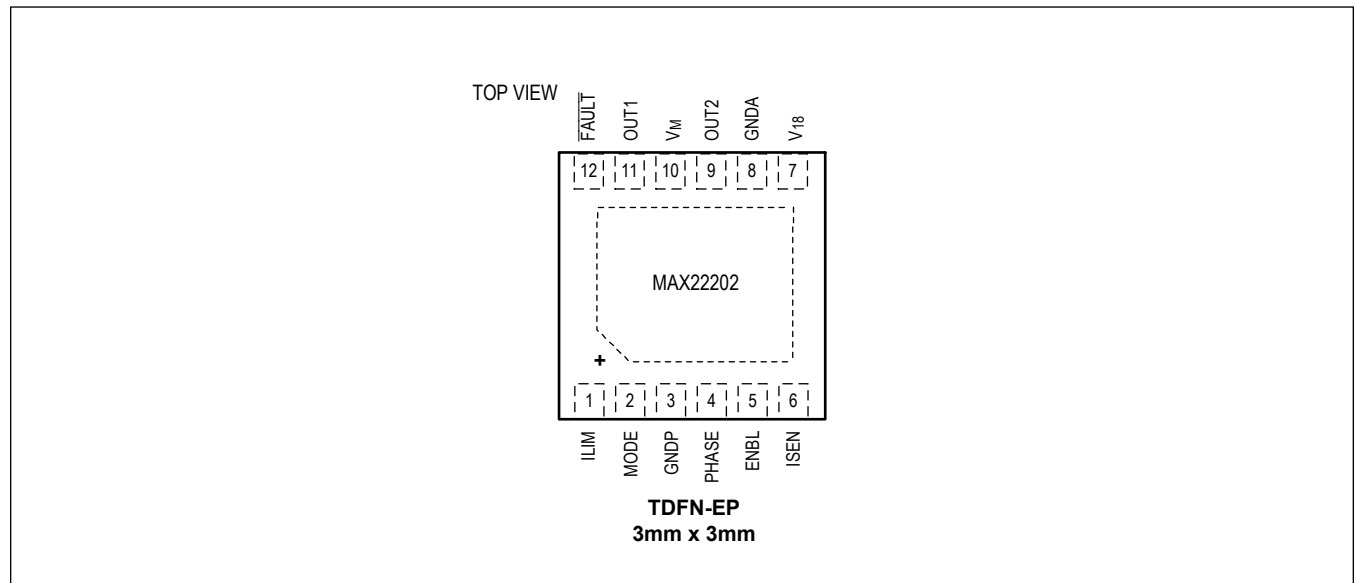

**MAX22207**

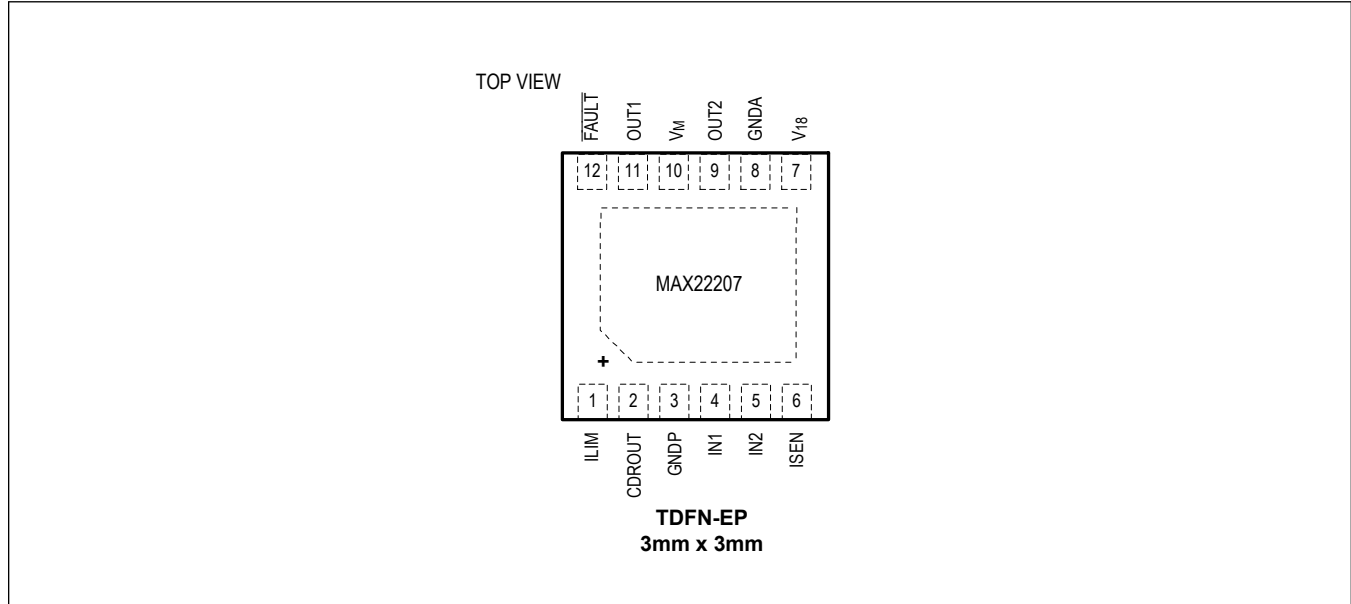

**Pin Description**

PIN			NAME	FUNCTION	TYPE
MAX22201	MAX22202	MAX22207			
1	1	1	ILIM	Programmable Current Limiter Analog Input. Connect a resistor from ILIM to GND to set the current limit.	Analog Input
2	—	—	ROFF	Programmable $t_{OFF}$ Time Analog Input. Leave ROFF unconnected to use the internal fixed $t_{OFF}$ time 20 $\mu$ s. Connect a Resistor from ROFF to GND to set the $t_{OFF}$ time to a desired value.	Analog Input
—	—	2	CDROUT	Current Drive Regulation Monitor Output. Open-drain output requires an external pullup. The output is asserted low when the motor current exceeds the $I_{TRIP}$ current threshold and the CDR is activated.	Open-Drain Output
12	12	12	$\overline{\text{FAULT}}$	Open-Drain Output. Active-low fault indicator.	Open-Drain Output
10	10	10	$V_M$	Supply-Voltage Input. Bypass $V_M$ pin to GND with a 1 $\mu$ F capacitor as close as possible to the pin plus a 47 $\mu$ F electrolytic bulk capacitor.	Supply
11	11	11	OUT1	Driver Output 1	Output
9	9	9	OUT2	Driver Output 2	Output
3	3	3	GNDP	Power Ground. Connect to ground plane (GND).	GND
7	7	7	$V_{18}$	LDO Output Pin. Connect 1 $\mu$ F from $V_{18}$ to GND.	Output
4	—	4	IN1	CMOS PWM Input 1	Logic Input
—	5	—	ENBL	Enable Logic Input	Logic Input
5	—	5	IN2	CMOS PWM Input 2	Logic Input
—	4	—	PHASE	Phase Logic Input	Logic Input



**Pin Description (continued)**

PIN			NAME	FUNCTION	TYPE
MAX22201	MAX22202	MAX22207			
—	2	—	MODE	Mode Logic Input	Logic Input
6	6	6	ISEN	Current Sense Monitor Output	Analog Output
8	8	8	GNDA	Power Ground. Connect to ground plane (GND).	GND

## Detailed Description

The MAX22201/MAX22202/MAX22207 integrate one +36V, 3.5A peak full-bridge for motor driver applications. The device can be used to drive one brushed DC motor. The full-bridge features very low-impedance FETs with a typical  $R_{ON}$  (high-side + low-side) of  $0.3\Omega$ . The peak current of 3.5A is limited by the overcurrent protection (OCP) threshold. The peak current is defined as the maximum current the driver can provide for short transients. The maximum RMS current is 2A and is typically limited by thermal considerations. The  $2A_{RMS}$  capability refers to a standard JEDEC 4-layer board at 25°C ambient temperature. The actual operating maximum current depends on the application thermal characteristic (PCB ground planes, heat sinks, ventilation, etc.).

The MAX22201/MAX22202/MAX22207 feature a nondissipative and accurate integrated current sensing (ICS) that senses the current flowing through low-side power FETs. This feature eliminates the need for external bulky and expensive power resistors and results in significant space and power saving compared with mainstream applications based on external power-sense resistors. An embedded internal current drive regulation (CDR) circuit regulates the peak output current effectively limiting the maximum inrush current during motor startup or a stall condition. The CDR current limit threshold ( $I_{TRIP}$ ) can be configured with an external standard resistor connected to pin ILIM. When the motor current exceeds  $I_{TRIP}$ , the full bridge enters in decay mode for a fixed off time ( $t_{OFF}$ ).

In brushed motor drive applications, the current drive regulation not only guarantees safe and reliable operations for the driver, but also reduces system power and supply bypassing requirements. A replica of the internally sensed current is output on the ISEN pin. By connecting an external standard resistor from this pin to GND, a voltage proportional to the motor current is generated. The voltage across this external resistor can be input into an external controller ADC when the motor-control algorithm requires the current/torque information. The user can select the resistor value so that the peak voltage meets the ADC full-scale requirement.

Three versions are available with various control interfaces.

- The MAX22201 and MAX22207 are controlled with two PWM logic inputs (IN1, IN2) resulting in 4 possible states: forward, reverse, brake (slow decay), and coast. Setting both inputs low for more than 2.2ms, the MAX22201 enters low-power sleep mode. The MAX22201 features a user configurable off time that can be set by connecting an external resistor to the ROFF pin.
- The MAX22202 features an ENBL/PHASE interface with an additional logic input pin (MODE) to select slow/fast decay. A break condition longer than 2.2ms followed by a high-to-low transition of the MODE pin enters low-power sleep mode.
- The MAX22207 features a CDR monitor open-drain output that is asserted when the internal regulation loop takes control of the driver.

All three versions feature overcurrent protection (OCP), thermal shutdown (TSD), and undervoltage lockout (UVLO) monitoring. An open-drain active-low fault indication pin (FAULT) is activated every time a fault condition is detected.

## Sleep Mode Description

### MAX22201/MAX22207

When both IN1 and IN2 inputs are low for longer than  $t_{SLEEP}$  (2.2ms max), the MAX22201 enters low-power sleep mode. In this mode, outputs are three-stated and the device current consumption is  $I_{SLEEP}$  (6.5 $\mu$ A max). If the device is powered up with both inputs low, sleep mode is immediately entered. To exit Sleep mode and power on the device, drive IN1 and IN2 high for at least 400 $\mu$ s.

### MAX22202 Only

The MAX22202 enters Sleep mode if the MODE pin is maintained high (brake/slow decay) for longer than  $t_{SLEEP}$  (2.2ms max) and afterwards is driven low. In this mode, outputs are three-stated and the device current consumption is  $I_{SLEEP}$  (10 $\mu$ A max). After power up, when MODE = 0, the device immediately enters in Sleep mode. To exit Sleep mode and power up the device, drive MODE high for at least 400 $\mu$ s ( $t_{ON}$  max).

## Motor Drive Control: Use Cases

The MAX22201/MAX22202/MAX22207 provide flexibility and support different use cases. The most common use cases

are described below.

### 1. PWM With Internal Current Drive Regulation

In this use case, the regulation current limit ( $I_{TRIP}$ ) is set above the normal operating current ( $I_{NOM}$ ) with the purpose of limiting the inrush current at motor startup. Afterwards, the external controller controls the motor by means of PWM signals for speed or position control. Normally brake (slow decay) is used during the off-phase as it results in low ripple and power consumption. However, fast- or mixed-decay control can also be implemented.

### 2. PWM Without Internal Current Drive Regulation

If the internal current regulation is not needed, a 14k $\Omega$  should be connected on the ILIM pin. In this configuration, the internal current drive regulation is disabled and the MAX22201/MAX22202/MAX22207 provide the maximum current (3.5A), which can only be sustained for a short period of time. In this use case, an external controller controls the motor by means of PWM signals for speed or position control. Normally brake (slow decay) is used during the off-phase as it results in low ripple and power consumption. However, fast- or mixed-decay control can also be implemented. Since the internal limiter is disabled, if the current is not properly controlled, it can reach the overcurrent protection threshold or the junction temperature can rise above the thermal protection threshold causing a fault condition and stress the device.

### 3. Internal Current Regulation only (no PWM)

In this use case, no PWM control signal is applied on logic inputs. These logic inputs are used just to enable/disable the full bridge or to set the current direction. The internal current regulation circuit controls the output current depending on the resistor value at ILIM. The torque control is simply implemented by setting the desired  $I_{TRIP}$  current. The correspondent motor speed results from the torque-speed characteristic of the motor. The user can also consider varying the current dynamically by changing the resistor connected to ILIM.

### 4. PWM Control Based on the ISEN Current

Similar to use cases 1 and 2, the driver is controlled with PWM signals. However, the MCU control algorithm requires feedback in the form of the motor current. To support this use case, the MAX22201/MAX22202/MAX22207 ISEN pins output a current proportional to the output current. A resistor connected to the ISEN pin makes the current-to-voltage conversion and can be monitored by the controller ADC. The internal current drive regulation can be either enabled (case 1) or disabled (case 2).

## Bridge Control

### MAX22201/MAX22207

The bridge driver is controlled by two logic inputs (IN1 and IN2) as shown in [Table 1](#)

**Table 1. Full Bridge IN1 and IN2 Truth Table**

IN1	IN2	OUT1	OUT2	DESCRIPTION
0	0	High-Z	High-Z	Coast; H-bridge disabled to High-Z (Sleep mode is entered after 2.2ms typ)
0	1	L	H	Reverse (current from OUT2 to OUT1)
1	0	H	L	Forward (current from OUT1 to OUT2)
1	1	L	L	Brake (slow decay)

PWM techniques can be used to control the output duty cycle to implement motor speed control. Typically, for brushed DC motor drivers, brake (slow decay) is preferred as it results in lower ripple, and hence, higher efficiency. With this approach during the off-phase, both the low-side FETs are activated shorting the motor winding. The current built up into the motor winding slowly decays. Alternatively, fast decay can also be implemented by reversing the bridge or by three-stating the bridge during the off-phase. The first method is referred to as synchronous fast decay. The second method, in which the decay current flows through the FETs body diodes, is referred to as asynchronous fast decay.

If the current exceeds the  $I_{TRIP}$  level and the internal current drive circuit is enabled, the internal regulation circuitry takes control over the bridge operations and [Table 1](#) no longer applies.

If IN1 and IN2 are held low for longer than  $t_{SLEEP}$ , the MAX22201 enters low-power Sleep mode.

### MAX22202 Only

The bridge driver is controlled by three logic inputs (PHASE, ENBL, MODE) as shown in [Table 2](#)

**Table 2. Full Bridge PHASE, ENBL, and MODE Truth Table**

PHASE	ENBL	MODE	OUT1	OUT2	DESCRIPTION
1	1	X	H	L	Forward (current from OUT1 to OUT2)
0	1	X	L	H	Reverse (current from OUT2 to OUT1)
X	0	1	L	L	Brake (slow decay)
1	0	0	L	H	Fast-decay synchronous rectification (*) Sleep mode if following a longer than $t_{SLEEP}$ brake status
0	0	0	H	L	Fast-decay synchronous rectification (*) Sleep mode if following a longer than $t_{SLEEP}$ brake status

(\*) To prevent reversal of current during fast decay synchronous rectification, outputs go to the high-impedance state as the current approaches 0A.

PWM techniques can be used to control the output duty cycle to implement motor speed control. Typically, for brushed DC motor drivers, PWM signal can be applied either on PHASE or ENBL logic inputs. In the latter case, the configuration mode pin (MODE) determines whether fast or brake (slow decay) mode is used. Brake (slow decay) is normally preferred as it results in less ripple, higher efficiency, and better control.

If the MAX22202 stays in brake (slow decay) conditions (MODE = 1, ENBL = 0) for longer than  $t_{SLEEP}$  and the MODE pin is driven low, then the MAX22202 enters in low-power Sleep mode.

If the current exceeds the  $I_{TRIP}$  level and the internal current drive circuit is enabled, [Table 2](#) no longer applies and the internal regulation circuitry takes control over the bridge operations.

### Integrated Current Sensing

The MAX22201/MAX22202/MAX22207 feature an accurate integrated current-sense circuit that eliminates the bulky sense resistors that are typically required for external sensing. This feature along with the very small package, significantly reduces the PCB space and cost. The sensing circuit is based on sense-FET techniques with no internal losses and thus results in extremely high efficiency. Therefore, MAX22201/MAX22202/MAX22207 are ideal choices for applications in which the motor driver heating is a concern.

Current sensing is performed on the two low side FETs independently. The current is sensed during the energizing (forward or reverse) and during the brake (slow decay) phase. In Fast Decay mode, the current is not sensed.

### Current Drive Regulation and Current Limiter (ILIM pin)

The MAX22201/MAX22202/MAX22207 feature a configurable current drive regulation circuit that limits the output current based on the value of an external resistor connected to the ILIM pin. Equation 1 can be used to set the desired current limit threshold:

$$I_{TRIP}(A) = \frac{K_{ILIM}(KV)}{R_{ILIM}(K\Omega)}$$

Equation 1: Current Limiter

In which  $R_{ILIM}$  is an external resistor connected between ILIM and GND and  $K_{ILIM}$  is 50kV (typ). For instance, to limit the peak current at 2A, an external resistance  $R_{ILIM} = 25k\Omega$  is required.

The closed-loop current drive regulation circuit controls the peak current and makes it equal to the  $I_{TRIP}$  current as in Equation 1. As soon as the output current exceeds the threshold ( $I_{TRIP}$ ) the device enforces the slow decay by enabling both low-side FETs for a fixed off time ( $t_{OFF}$ ). The fixed off-time is internally set at 20 $\mu$ s (typ) for the MAX22202 and MAX22207, whereas it is user-configurable for the MAX22201 (see the [Fixed Off-Time Configuration \(ROFF\) \(MAX22201 Only\)](#) section).

Note that the internal loop regulates the peak current and the average current depends on the ripple. A smaller ripple allows a better control of the average current.

During  $t_{OFF}$ , if the control inputs are kept steady, the driver remains in slow-decay drive mode for the entire duration of

the  $t_{OFF}$  time. Toggling the PWM signals during  $t_{OFF}$  causes the  $t_{OFF}$  timer to reset and control of the H-Bridges are returned to PWM inputs. At the end of the  $t_{OFF}$  interval, if the current is less than  $I_{TRIP}$ , control of the H-Bridges returns to the PWM inputs; otherwise, an additional  $t_{OFF}$  time is appended (see [Figure 2](#)).

The current drive regulation limits the maximum inrush current during motor startup or stall conditions. For a brushed motor drive application, this feature not only guarantees safe and reliable operations for the driver, but also reduces requirements of the supply power and its bypassing. During current limitation, the output duty cycle and frequency depends on the supply voltage, motor inductance,  $t_{OFF}$  value, and motor speed.

### Fixed Off-Time Configuration (ROFF) (MAX22201 Only)

With the MAX22201 device, it is possible to configure the fixed off time ( $t_{OFF}$ ) to a desired value. When the ROFF pin is left unconnected, the  $t_{OFF}$  time is set at a fixed value (20 $\mu$ s typ). By connecting an external resistor to the ROFF pin, the user can configure  $t_{OFF}$  according to Equation 2.

$$t_{OFF}(\mu\text{s}) = R_{ROFF}(\text{k}\Omega) \times C_{OFF}(\text{nF})$$

Equation 2:  $t_{OFF}$  Configuration

in which  $R_{ROFF}$  is an external resistor connected to the ROFF pin (in k $\Omega$ ) and  $C_{OFF}$  is an internal constant equal to 0.333nF.  $t_{OFF}$  can be programmed in a range from 10 $\mu$ s to 80 $\mu$ s (typ).

### Current Sense Output: Current Monitor

A replica of the internally sensed current is output on the ISEN pin. The current is sensed when one of the two low-side FETs sinks the output current and is therefore meaningful both during the energizing ( $t_{ON}$ ) phase and during the brake (slow decay) phase. In fast decay, the current is not monitored and ISEN outputs a zero current. Equation 3 shows the relationship between the current sourced at ISEN and the output current.

$$I_{ISEN}(A) = \frac{I_{OUT}(A)}{K_{ISEN}}$$

Equation 3: ISEN Output Current

in which  $K_{ISEN}$  represents the current scaling factor between the output current and its replica at the ISEN pin.  $K_{ISEN}$  is 5kA/A (typ). For instance, if the instantaneous output current is 2A, the current sourced at ISEN is 400 $\mu$ A.

[Figure 1](#) shows an idealized behavior of the ISEN current when slow or fast decay are used. Blanking times, delays, and rise/fall edges have been ignored.

By connecting an external standard resistor,  $R_{ISEN}$ , between ISEN and GND a voltage proportional to the motor current is generated. The voltage built up on  $R_{ISEN}$  can be input into an ADC of an external controller in applications where the motor control algorithm requires the current/torque information (see the [Typical Application Circuits](#) section). The system designer can choose the  $R_{ISEN}$  value so that the peak voltage meets the ADC full-scale requirement. Equation 4 shows the design formula to calculate  $R_{ISEN}$  once the ADC full-scale voltage ( $V_{FS}$ ) and the maximum operating current ( $I_{MAX}$ ) are known.

$$R_{ISEN}(\Omega) = K_{ISEN} \times \frac{V_{FS}(V)}{I_{MAX}(A)}$$

Equation 4:  $R_{ISEN}$  Setting

For example, if the ADC operates up to 1V full-scale and the maximum operating output current is 2A, then  $R_{ISEN}$  would be  $5000 \times 1V/2A = 2.5k\Omega$ .

The  $R_{ISEN}$  value also sets the output impedance of the current sense output circuit (ISEN output impedance). Normally, the input impedance of the ADC is much higher than  $R_{ISEN}$  so that it can be directly connected to the ISEN pin without affecting the accuracy of the measurement. In case a low input impedance ADC is used, a pre-amplifier (buffer) might be required.

The current sense output circuit bandwidth and step response performances (see the [Electrical Characteristics](#) section) ensure the current monitor tracks the driver current in motor drive applications.

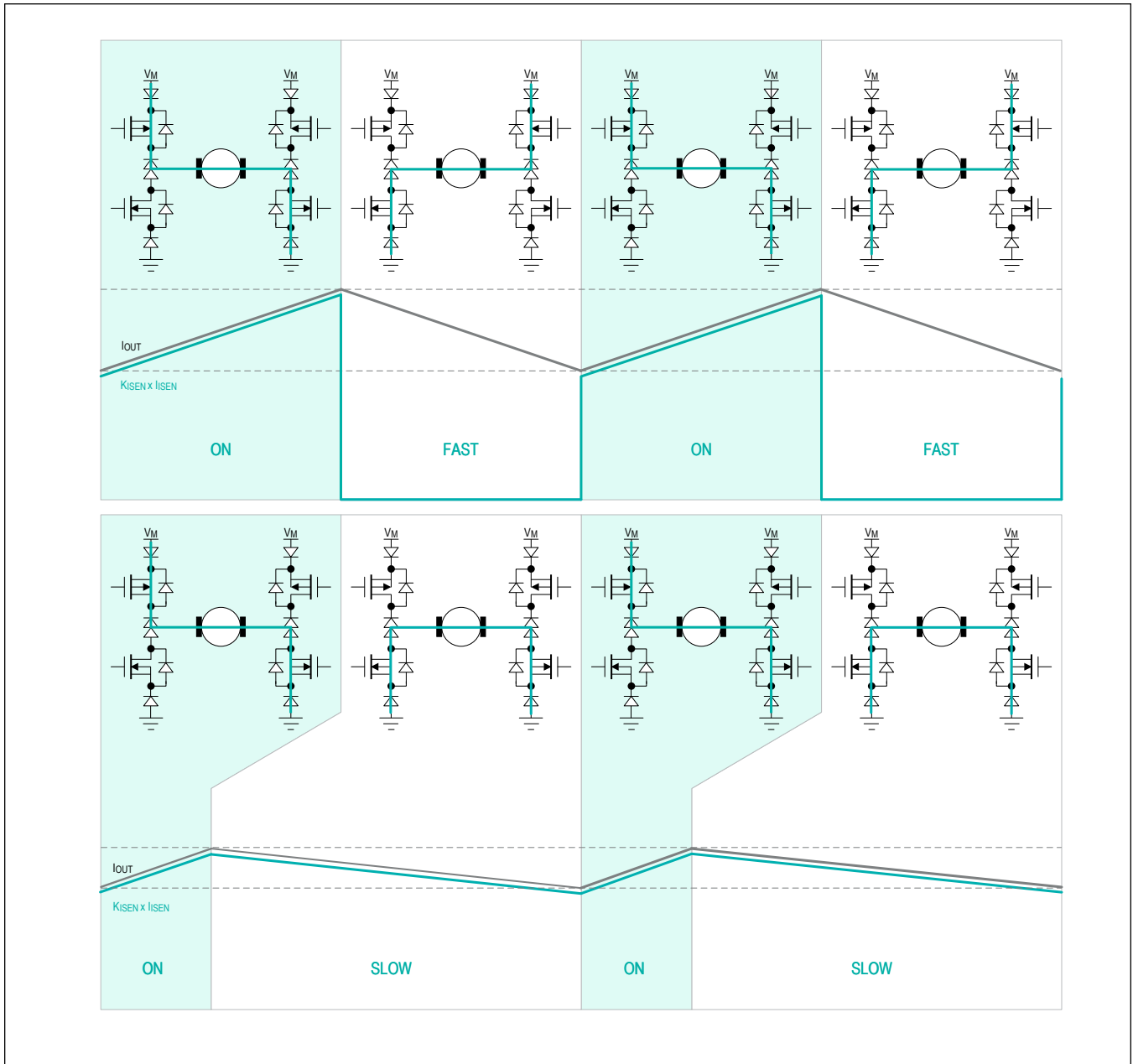

Figure 1. ISEN Current

**CDROUT (MAX22207 Only)**

The CDROUT pin indicates when the MAX22207 has entered in current drive regulation so that the brake (slow decay) drive mode is forced by the internal regulation loop (see the [Current Drive Regulation and Current Limiter \(ILIM pin\)](#) section).

CDROUT is an open-drain output. When this function is used, an external pullup must be connected to the controller logic supply voltage. During forward or reverse drive mode, if the motor current is below the limiter threshold ( $I_{TRIP}$ ), CDROUT is pulled up by the external resistor (logic high). When the motor current rises above  $I_{TRIP}$ , the CDR enforces a slow decay drive mode and the CDROUT is driven to logic low. Note that if the H-bridge is put into a slow decay mode using the logic inputs (IN1 and IN2), the CDROUT is not driven low.

[Figure 2](#) shows the behavior of the motor current and of the CDROUT indication pin. The CDROUT is asserted only when the slow decay mode is forced by the internal CDR.

Notice that any PWM transitions resets the fixed off time of the CDR circuit. In case A, the actual brake (slow decay) interval is shorter than  $t_{OFF}$ , whereas in case B, the actual brake (slow decay) off interval is longer.

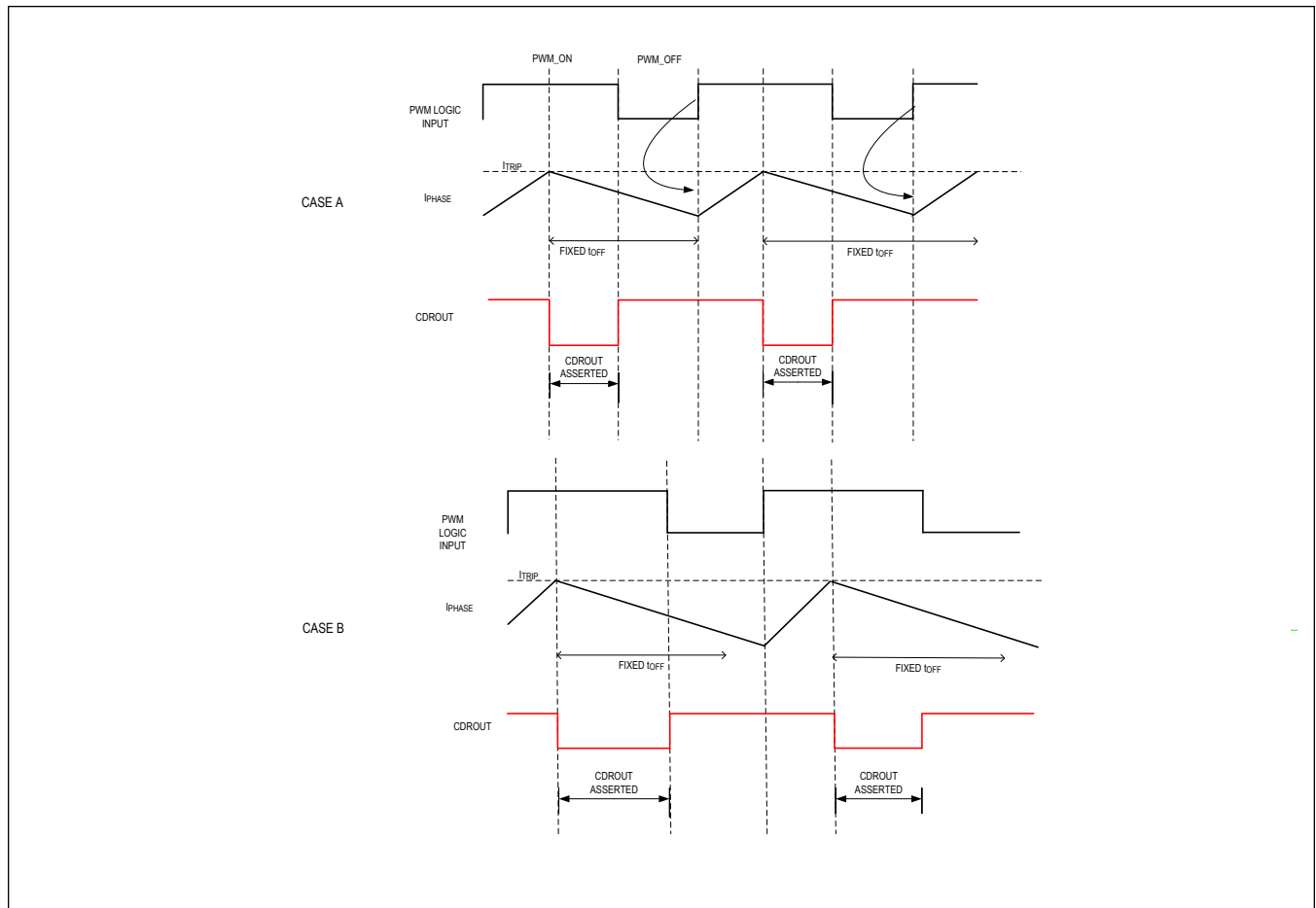

Figure 2. Current Drive Regulation Behavior

## Protections

### Overcurrent Protection (OCP)

The MAX22201/MAX22202/MAX22207 are protected against short circuits to the rails (supply voltage and ground) and between the outputs (OUT1 and OUT2). When one of these fault events occur, the integrated current regulation circuit cannot limit the current and extra protections are necessary. When a short-circuit is detected, namely the overcurrent protection threshold is reached, a fault indication is output to the  $\overline{\text{FAULT}}$  pin and the H-bridge is disabled for a 2ms (see  $t_{\text{RETRY}}$  specification in the [Electrical Characteristics](#)). After that, the H-bridge is re-enabled according to the state of input logic control pins. If the short-circuit is still present, this cycle repeats; otherwise, normal operation resumes. The OCP threshold is set at 3.5A (min). It is recommended to avoid prolonged operation in short-circuit failure mode since a prolonged OCP auto-retry could affect the device reliability.

### Thermal Shutdown Protection

If the die temperature exceeds about 165°C, a fault indication is output on the  $\overline{\text{FAULT}}$  pin and the H-bridge is three-stated until the junction temperature drops below 135°C. After that, the H-Bridge is re-enabled.

### Undervoltage Lockout (UVLO)

The device features undervoltage lockout (UVLO) protections. UVLO on  $V_M$  is set at 3V (max). When a UVLO event occurs, a fault indication is output on the  $\overline{\text{FAULT}}$  pin and the outputs are three-stated. As soon as the supply voltages are back to the nominal operating range, normal operations are resumed and the  $\overline{\text{FAULT}}$  pin is deasserted.

### ESD Protection

The MAX22201/MAX22202/MAX22207 output pins (OUT1 and OUT2) are protected up to 10kV HBM when the part is mounted on a board with at least 1 $\mu$ F bypass capacitor on  $V_M$ .



Typical Application Circuits

MAX22201

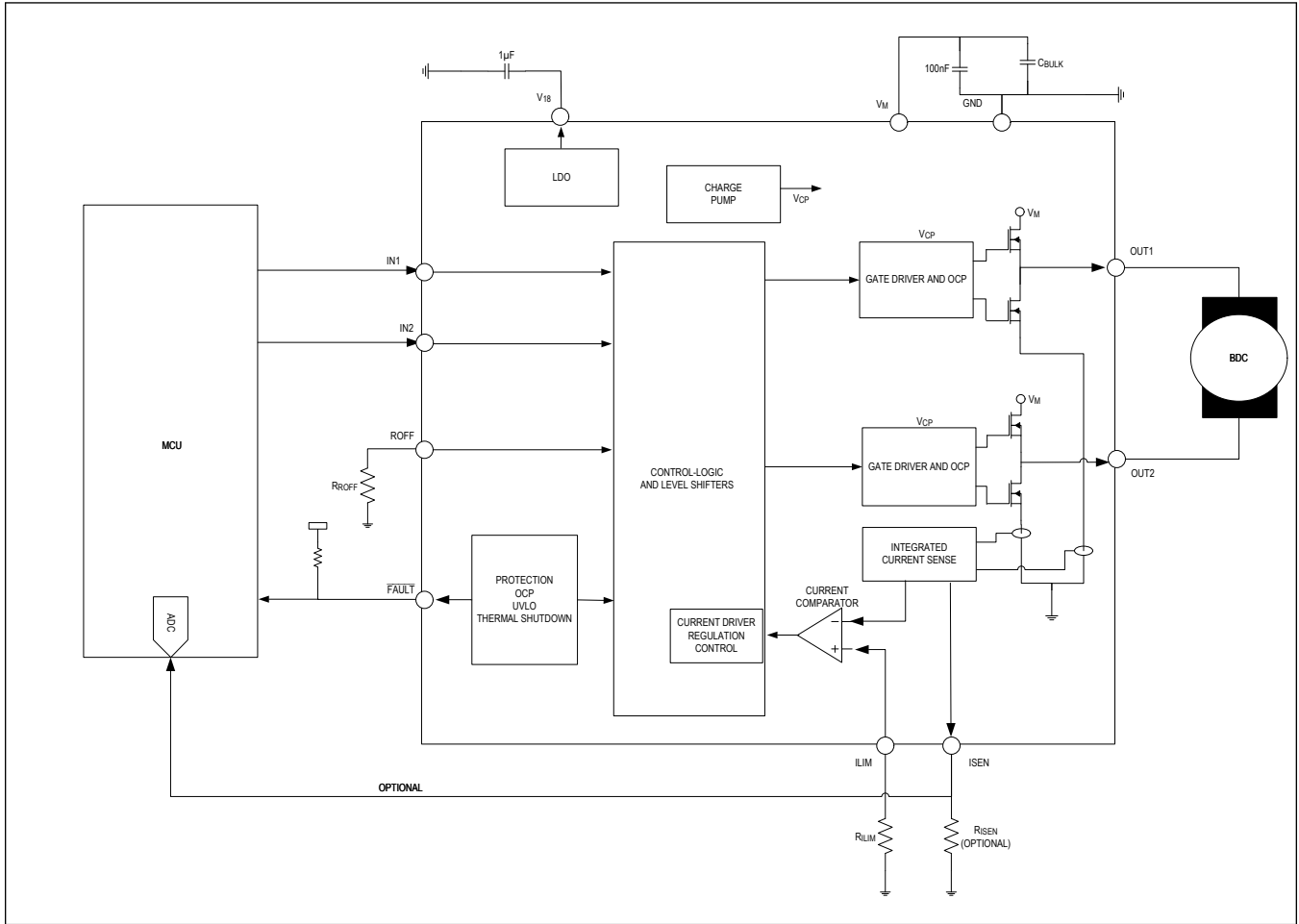



Typical Application Circuits (continued)

MAX22207

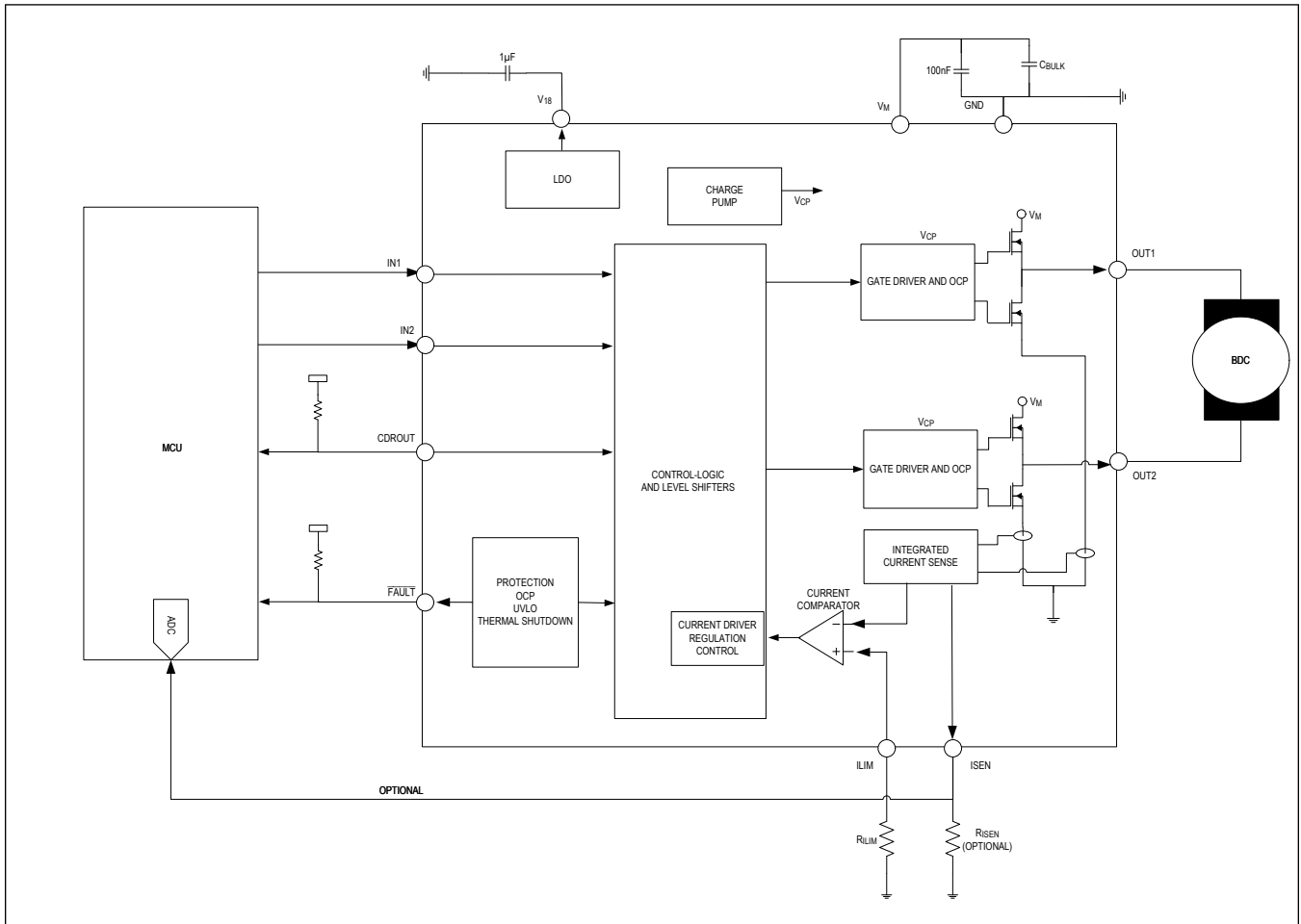

Ordering Information

PART NUMBER	TEMP RANGE	PIN-PACKAGE
MAX22201ATC+	-40°C to +125°C	12-TDFN
MAX22201ATC+T	-40°C to +125°C	12-TDFN
MAX22202ATC+	-40°C to +125°C	12-TDFN
MAX22202ATC+T	-40°C to +125°C	12-TDFN
MAX22207ATC+	-40°C to +125°C	12-TDFN
MAX22207ATC+T	-40°C to +125°C	12-TDFN

+ Denotes lead(Pb)-free/RoHS compliance.

T = Tape-and-reel.

## Revision History

REVISION NUMBER	REVISION DATE	DESCRIPTION	PAGES CHANGED
0	12/20	Release for Market Intro	—
1	12/20	Added TOC01–TOC09 and updated the <i>CDROUT (MAX22207 Only)</i> section	6, 15
2	1/22	Updated <i>Simplified Block Diagram</i> and <i>Ordering Information</i>	2, 19