

THIS DRAWING IS UNPUBLISHED. RELEASED FOR PUBLICATION
 © COPYRIGHT - By - ALL RIGHTS RESERVED.

Loc		DIST		REVISIONS			
P	LTR	DESCRIPTION		DATE	DWN	APVD	
AD	00	N5	REVISED PER ECO-11-004587	11MAR11	RK	HMR	

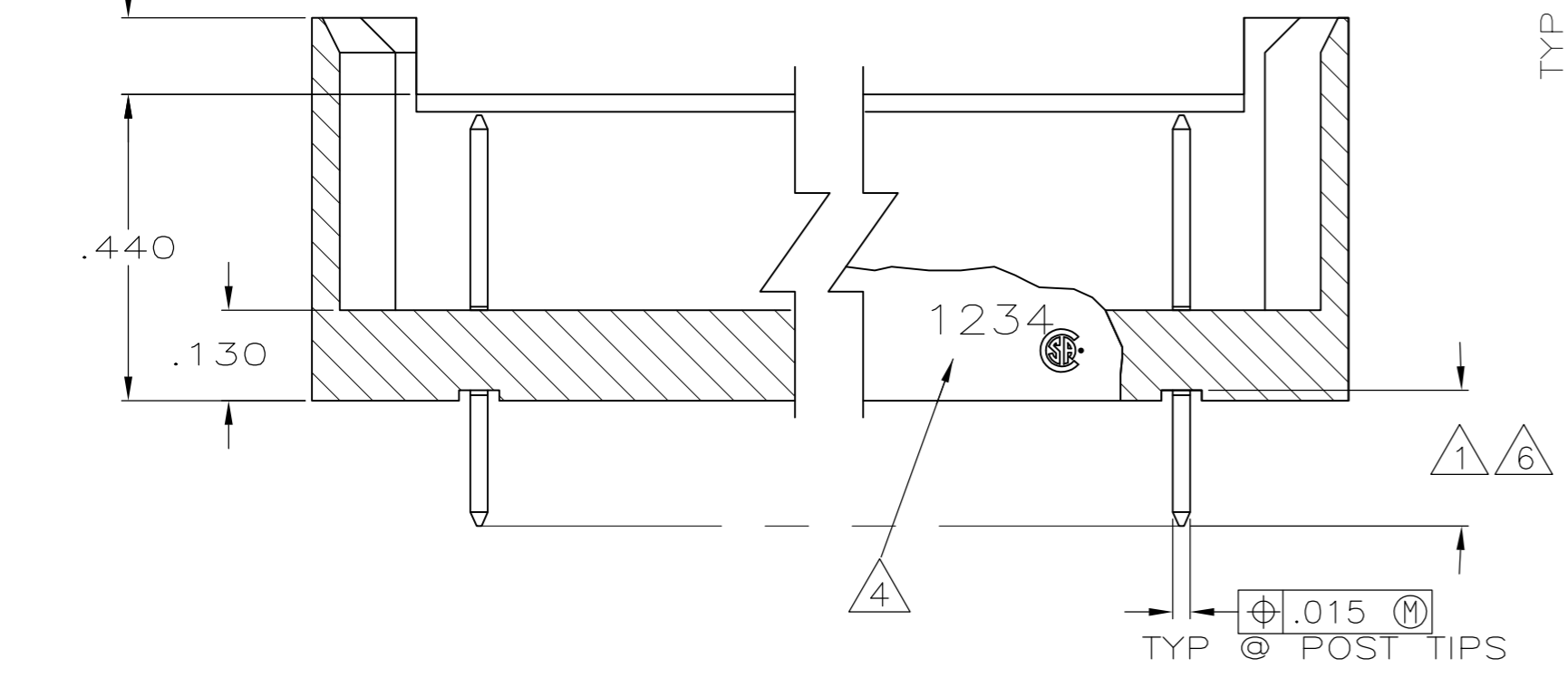

SECT Y-Y

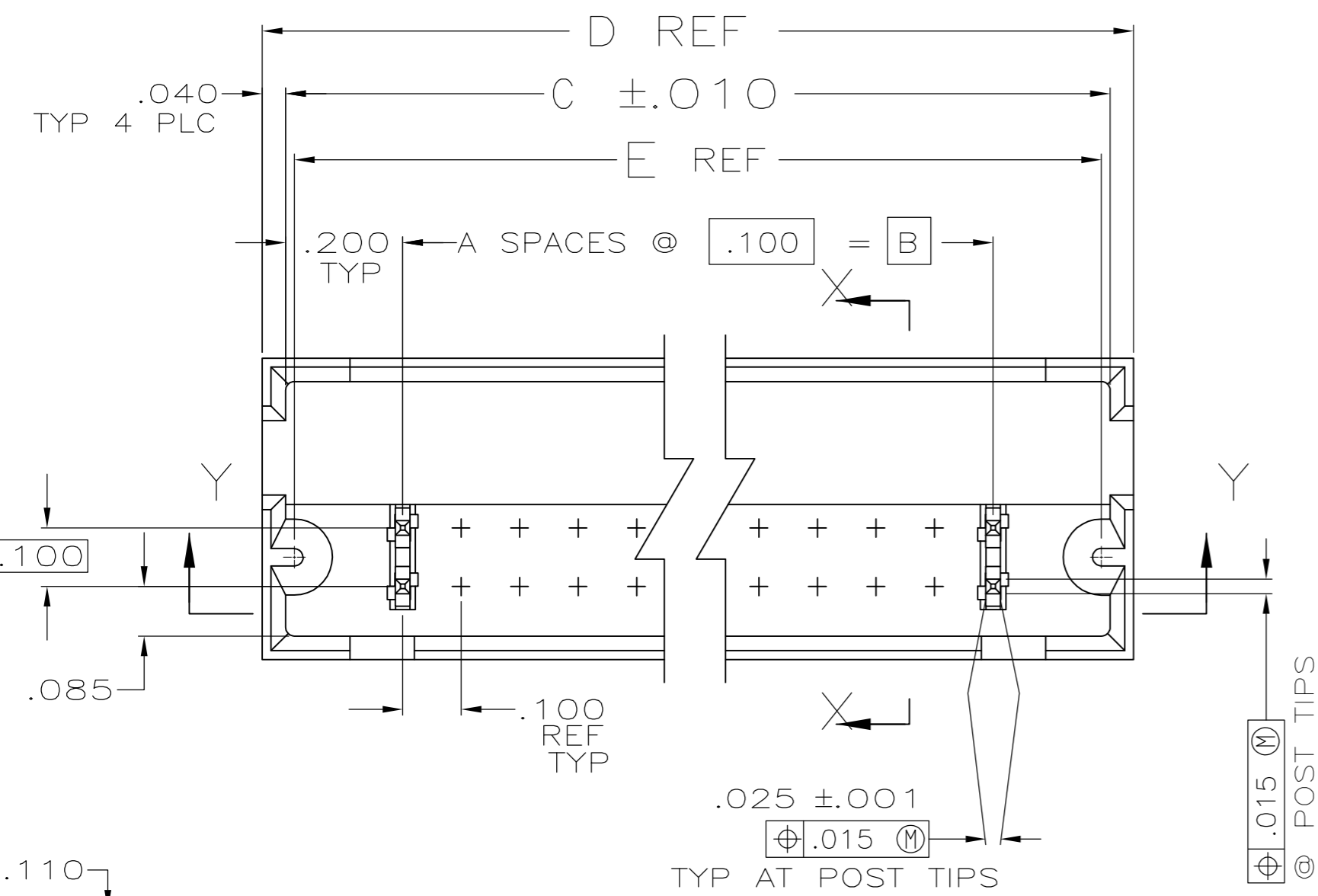
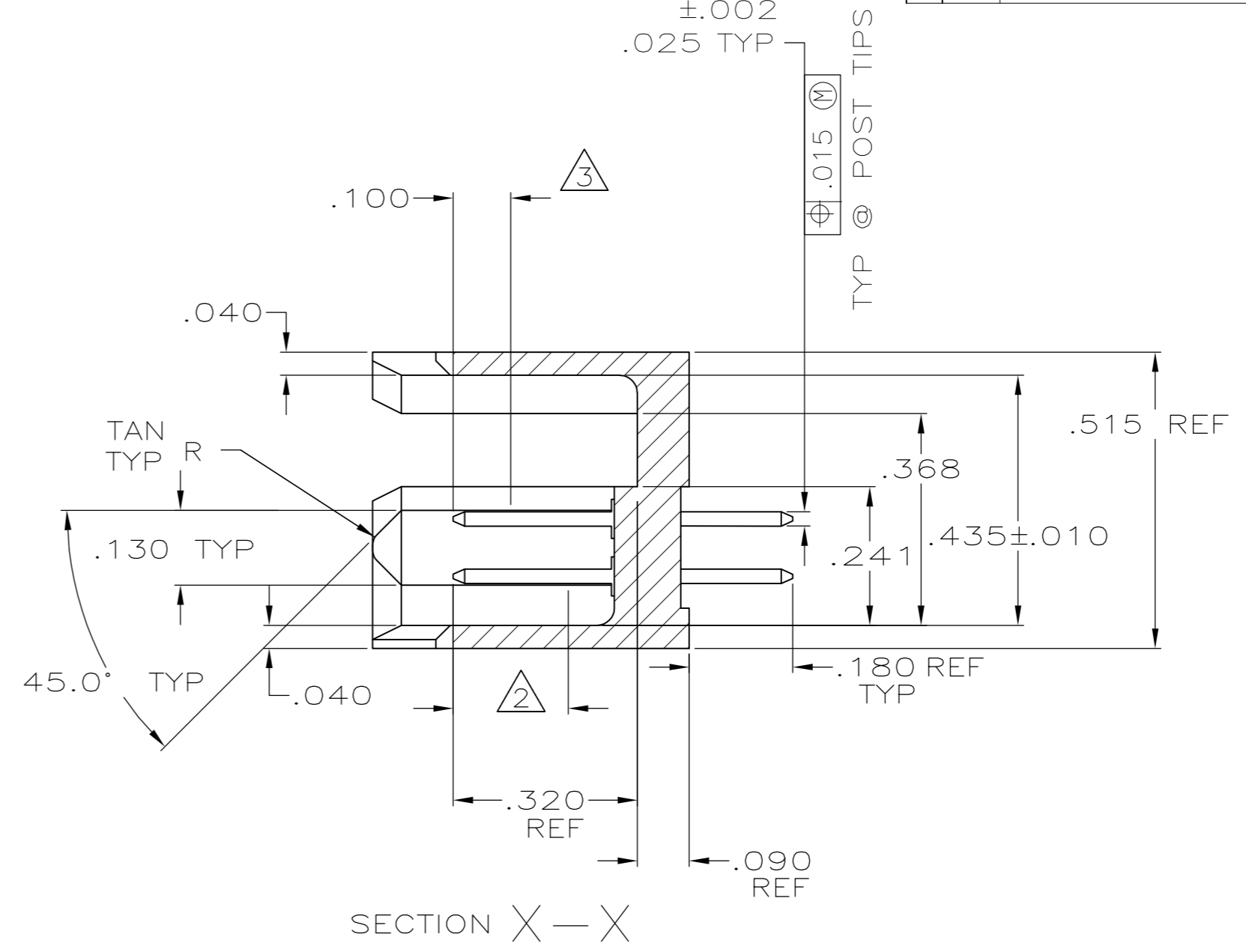

SECTION X-X

- ① FINISH OVER INDICATED AREA: .000100-.000200 BRIGHT TIN LEAD OVER .000050 NICKEL.
- ② FINISH OVER INDICATED AREA: .000015 GOLD OVER .000050 NICKEL.
- ③ POINT OF MEASUREMENT FOR PLATING THICKNESS.
- ④ RECESSED DATE CODE AND CSA LOGO.
- ⑤ OBSOLETE PART NUMBER.
- ⑥ FINISH OVER INDICATED AREA: .000100-.000200 MATTE TIN OVER .000050 NICKEL.
- ⑦ PRELIMINARY PART.
- ⑧ ROHS 2002/95/EC COMPLIANT
- ⑨ HEADER: GLASS-FILLED, FLAME RETARDANT THERMOPLASTIC COLOR: BLACK POST: COPPER ALLOY
- ⑩ OBSOLETE PARTS: OBSOLETE CIS STREAMLINING PER D.RENAUD/D.SINISI

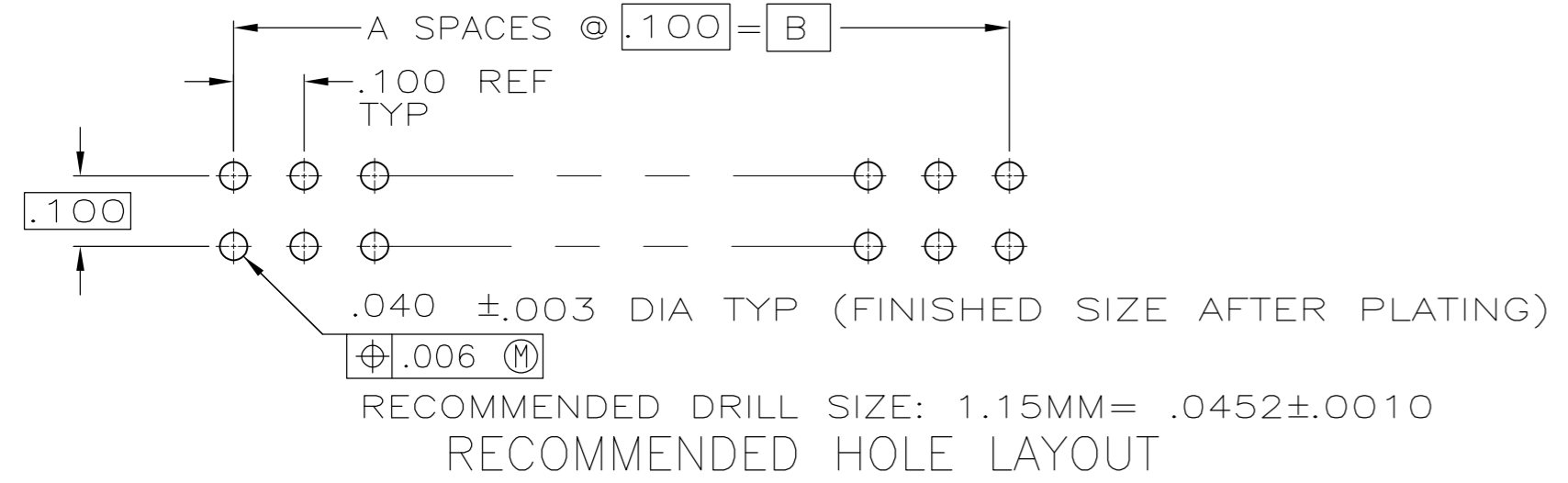

THIS DRAWING IS A CONTROLLED DOCUMENT.		DWN	B. HAYMAKER	30MAR00	 TE Connectivity
DIMENSIONS: mm		CHK	J. GESFORD	30MAR00	
TOLERANCES UNLESS OTHERWISE SPECIFIED:		APVD	J. GESFORD	30MAR00	NAME
0 PLC	± -	PRODUCT SPEC	HEADER ASSEMBLY, MOD II, .100 X .100CL		
1 PLC	± -	APPLICATION SPEC	SIZE	A2	CAGE CODE
2 PLC	± -	WEIGHT	00779	DRAWING NO	C=102567
3 PLC	± .005	MATERIAL	9	SCALE	4:1
4 PLC	± -	FINISH	SEE NOTES	SHEET	1 of 2
ANGLES	± -	CUSTOMER DRAWING		REV	N5

THIS DRAWING IS UNPUBLISHED. RELEASED FOR PUBLICATION
 © COPYRIGHT - By - ALL RIGHTS RESERVED.

LOC	DIST	REVISIONS					
AD	00	P	LTR	DESCRIPTION	DATE	DWN	APVD
		-		SEE SHEET 1	-	-	-

		1.870	1.980	1.900	1.500	15	32		7-102567-9
	OBSOLETE	9.270	9.380	9.300	8.900	89	180		7-102567-8
		7.670	7.780	7.700	7.300	73	148		7-102567-7
		6.670	6.780	6.700	6.300	63	128		7-102567-6
		4.970	5.080	5.000	4.600	46	94		7-102567-5
		2.470	2.580	2.500	2.100	21	44		7-102567-4
	OBSOLETE	.970	1.080	1.000	.600	6	14		7-102567-3
		8.270	8.380	8.300	7.900	79	160		7-102567-2
	OBSOLETE	10.270	10.380	10.300	9.900	99	200		7-102567-1
		7.270	7.380	7.300	6.900	69	140		7-102567-0
	OBSOLETE	6.770	6.880	6.800	6.400	64	130		6-102567-9
		1.070	1.180	1.100	.700	7	16		6-102567-8
	OBSOLETE	4.570	4.680	4.600	4.200	42	86		6-102567-7
		3.870	3.980	3.900	3.500	35	72		6-102567-6
		5.770	5.880	5.800	5.400	54	110		6-102567-5
	OBSOLETE	4.770	4.880	4.800	4.400	44	90		6-102567-4
		1.770	1.880	1.800	1.400	14	30		6-102567-3
		2.270	2.380	2.300	1.900	19	40		6-102567-2
		1.270	1.380	1.300	.900	9	20		6-102567-1
		3.770	3.880	3.800	3.400	34	70		6-102567-0
	OBSOLETE	5.270	5.380	5.300	4.900	49	100		5-102567-9
		4.270	4.380	4.300	3.900	39	80		5-102567-8
	OBSOLETE	6.270	6.380	6.300	5.900	59	120		5-102567-7
		2.770	2.880	2.800	2.400	24	50		5-102567-6
	OBSOLETE	5.070	5.180	5.100	4.700	47	96		5-102567-5
		3.270	3.380	3.300	2.900	29	60		5-102567-4
		2.070	2.180	2.100	1.700	17	36		5-102567-3
		1.470	1.580	1.500	1.100	11	24		5-102567-2
		.870	.980	.900	.500	5	12		5-102567-1
FINISH		E	D	C	B	A	NO. OF POSN		PART NUMBER

SUPERSEDED BY 5-102567-1												.870	.980	.900	.500	5	12	3-102567-0
		OBSOLETE										1.870	1.980	1.900	1.500	15	32	2-102567-9
		OBSOLETE										9.270	9.380	9.300	8.900	89	180	2-102567-8
		OBSOLETE										7.670	7.780	7.700	7.300	73	148	2-102567-7
		OBSOLETE										6.670	6.780	6.700	6.300	63	128	2-102567-6
		OBSOLETE										4.970	5.080	5.000	4.600	46	94	2-102567-5
		OBSOLETE										2.470	2.580	2.500	2.100	21	44	2-102567-4
		OBSOLETE										.970	1.080	1.000	.600	6	14	2-102567-3
		OBSOLETE										8.270	8.380	8.300	7.900	79	160	2-102567-2
		OBSOLETE										10.270	10.380	10.300	9.900	99	200	2-102567-1
		OBSOLETE										7.270	7.380	7.300	6.900	69	140	2-102567-0
		OBSOLETE										6.770	6.880	6.800	6.400	64	130	1-102567-9
		OBSOLETE										1.070	1.180	1.100	.700	7	16	1-102567-8
		OBSOLETE										4.570	4.680	4.600	4.200	42	86	1-102567-7
		OBSOLETE										3.870	3.980	3.900	3.500	35	72	1-102567-6
		OBSOLETE										5.770	5.880	5.800	5.400	54	110	1-102567-5
		OBSOLETE										4.770	4.880	4.800	4.400	44	90	1-102567-4
		OBSOLETE										1.770	1.880	1.800	1.400	14	30	1-102567-3
		OBSOLETE										2.270	2.380	2.300	1.900	19	40	1-102567-2
		OBSOLETE										1.270	1.380	1.300	.900	9	20	1-102567-1
		OBSOLETE										3.770	3.880	3.800	3.400	34	70	1-102567-0
		OBSOLETE										5.270	5.380	5.300	4.900	49	100	102567-9
		OBSOLETE										4.270	4.380	4.300	3.900	39	80	102567-8
		OBSOLETE										6.270	6.380	6.300	5.900	59	120	102567-7
		OBSOLETE										2.770	2.880	2.800	2.400	24	50	102567-6
		OBSOLETE										5.070	5.180	5.100	4.700	47	96	102567-5
		OBSOLETE										3.270	3.380	3.300	2.900	29	60	102567-4
		OBSOLETE										2.070	2.180	2.100	1.700	17	36	102567-3
		OBSOLETE										1.470	1.580	1.500	1.100	11	24	102567-2
		OBSOLETE										.870	.980	.900	.500	5	12	102567-1
FINISH		E	D	C	B	A	NO. OF POSN		PART NUMBER									

THIS DRAWING IS A CONTROLLED DOCUMENT.		DWN B. HAYMAKER 30MAR00	TE Connectivity	
DIMENSIONS: mm		CHK J. GESFORD 30MAR00		
TOLERANCES UNLESS OTHERWISE SPECIFIED: 0 PLC ± - 1 PLC ± - 2 PLC ± - 3 PLC ± .005 4 PLC ± - ANGLES ± -		APVD J. GESFORD 30MAR00	NAME HEADER ASSEMBLY, MOD II, .100 X .100CL	
MATERIAL -		PRODUCT SPEC -	SIZE A2	RESTRICTED TO -
SEE NOTES		APPLICATION SPEC -	CAGE CODE 00779	DRAWING NO C=102567
CUSTOMER DRAWING		WEIGHT -	SCALE 4:1	SHEET 2 of 2
			REV N5	