



MICROCHIP

EVB-KSZ9477
Gigabit Ethernet Switch
Evaluation Board
User's Guide

Note the following details of the code protection feature on Microchip devices:

- Microchip products meet the specification contained in their particular Microchip Data Sheet.
- Microchip believes that its family of products is one of the most secure families of its kind on the market today, when used in the intended manner and under normal conditions.
- There are dishonest and possibly illegal methods used to breach the code protection feature. All of these methods, to our knowledge, require using the Microchip products in a manner outside the operating specifications contained in Microchip's Data Sheets. Most likely, the person doing so is engaged in theft of intellectual property.
- Microchip is willing to work with the customer who is concerned about the integrity of their code.
- Neither Microchip nor any other semiconductor manufacturer can guarantee the security of their code. Code protection does not mean that we are guaranteeing the product as "unbreakable."

Code protection is constantly evolving. We at Microchip are committed to continuously improving the code protection features of our products. Attempts to break Microchip's code protection feature may be a violation of the Digital Millennium Copyright Act. If such acts allow unauthorized access to your software or other copyrighted work, you may have a right to sue for relief under that Act.

Information contained in this publication regarding device applications and the like is provided only for your convenience and may be superseded by updates. It is your responsibility to ensure that your application meets with your specifications. MICROCHIP MAKES NO REPRESENTATIONS OR WARRANTIES OF ANY KIND WHETHER EXPRESS OR IMPLIED, WRITTEN OR ORAL, STATUTORY OR OTHERWISE, RELATED TO THE INFORMATION, INCLUDING BUT NOT LIMITED TO ITS CONDITION, QUALITY, PERFORMANCE, MERCHANTABILITY OR FITNESS FOR PURPOSE. Microchip disclaims all liability arising from this information and its use. Use of Microchip devices in life support and/or safety applications is entirely at the buyer's risk, and the buyer agrees to defend, indemnify and hold harmless Microchip from any and all damages, claims, suits, or expenses resulting from such use. No licenses are conveyed, implicitly or otherwise, under any Microchip intellectual property rights unless otherwise stated.

Trademarks

The Microchip name and logo, the Microchip logo, AnyRate, AVR, AVR logo, AVR Freaks, BeaconThings, BitCloud, CryptoMemory, CryptoRF, dsPIC, FlashFlex, flexPWR, Helder, JukeBlox, KEELOQ, KEELOQ logo, Kleer, LANCheck, LINK MD, maXStylus, maXTouch, MediaLB, megaAVR, MOST, MOST logo, MPLAB, OptoLyzer, PIC, picoPower, PICSTART, PIC32 logo, Prochip Designer, QTouch, RightTouch, SAM-BA, SpyNIC, SST, SST Logo, SuperFlash, tinyAVR, UNI/O, and XMEGA are registered trademarks of Microchip Technology Incorporated in the U.S.A. and other countries.

ClockWorks, The Embedded Control Solutions Company, EtherSynch, Hyper Speed Control, HyperLight Load, IntelliMOS, mTouch, Precision Edge, and Quiet-Wire are registered trademarks of Microchip Technology Incorporated in the U.S.A.

Adjacent Key Suppression, AKS, Analog-for-the-Digital Age, Any Capacitor, AnyIn, AnyOut, BodyCom, chipKIT, chipKIT logo, CodeGuard, CryptoAuthentication, CryptoCompanion, CryptoController, dsPICDEM, dsPICDEM.net, Dynamic Average Matching, DAM, ECAN, EtherGREEN, In-Circuit Serial Programming, ICSP, Inter-Chip Connectivity, JitterBlocker, KlearNet, KlearNet logo, Mindi, MiWi, motorBench, MPASM, MPF, MPLAB Certified logo, MPLIB, MPLINK, MultiTRAK, NetDetach, Omniscient Code Generation, PICDEM, PICDEM.net, PICkit, PICtail, PureSilicon, QMatrix, RightTouch logo, REAL ICE, Ripple Blocker, SAM-ICE, Serial Quad I/O, SMART-I.S., SQI, SuperSwitcher, SuperSwitcher II, Total Endurance, TSHARC, USBCheck, VariSense, ViewSpan, WiperLock, Wireless DNA, and ZENA are trademarks of Microchip Technology Incorporated in the U.S.A. and other countries.

SQTP is a service mark of Microchip Technology Incorporated in the U.S.A.

Silicon Storage Technology is a registered trademark of Microchip Technology Inc. in other countries.

GestIC is a registered trademark of Microchip Technology Germany II GmbH & Co. KG, a subsidiary of Microchip Technology Inc., in other countries.

All other trademarks mentioned herein are property of their respective companies.

© 2017, Microchip Technology Incorporated, All Rights Reserved.

ISBN: 978-1-5224-1581-7

**QUALITY MANAGEMENT SYSTEM
CERTIFIED BY DNV
= ISO/TS 16949 =**

Microchip received ISO/TS-16949:2009 certification for its worldwide headquarters, design and wafer fabrication facilities in Chandler and Tempe, Arizona; Gresham, Oregon and design centers in California and India. The Company's quality system processes and procedures are for its PIC® MCUs and dsPIC® DSCs, KEELOQ® code hopping devices, Serial EEPROMs, microperipherals, nonvolatile memory and analog products. In addition, Microchip's quality system for the design and manufacture of development systems is ISO 9001:2000 certified.

Object of Declaration: EVB-KSZ9477

EU Declaration of Conformity

This declaration of conformity is issued by the manufacturer.

The development/evaluation tool is designed to be used for research and development in a laboratory environment. This development/evaluation tool is not a Finished Appliance, nor is it intended for incorporation into Finished Appliances that are made commercially available as single functional units to end users under EU EMC Directive 2004/108/EC and as supported by the European Commission's Guide for the EMC Directive 2004/108/EC (8th February 2010).

This development/evaluation tool complies with EU RoHS2 Directive 2011/65/EU.

This development/evaluation tool, when incorporating wireless and radio-telecom functionality, is in compliance with the essential requirement and other relevant provisions of the R&TTE Directive 1999/5/EC and the FCC rules as stated in the declaration of conformity provided in the module datasheet and the module product page available at www.microchip.com. For information regarding the exclusive, limited warranties applicable to Microchip products, please see Microchip's standard terms and conditions of sale, which are printed on our sales documentation and available at www.microchip.com.

Signed for and on behalf of Microchip Technology Inc. at Chandler, Arizona, USA.

Derek Carlson

VP Development Tools

Date

NOTES:

Table of Contents

Preface	7
Introduction.....	7
Document Layout	7
Conventions Used in this Guide	8
The Microchip Web Site	9
Development Systems Customer Change Notification Service	9
Customer Support	9
Document Revision History	10
Chapter 1. Overview	
1.1 Introduction	11
1.2 References	12
1.3 Terms and Abbreviations	13
Chapter 2. Board Details & Configuration	
2.1 Power	15
2.1.1 +5V Power	15
2.2 Resets	15
2.2.1 Power-on Reset	15
2.3 Clocks	15
2.4 Configuration	16
2.4.1 Switch Settings	17
2.4.2 Jumper Settings	17
2.4.3 SPI and I2C	18
2.4.4 LED Status	18
2.5 Mechanicals	19
Appendix A. EVB-KSZ9477 Evaluation Board	
A.1 Introduction	21
Appendix B. KSZ9477 Evaluation Board Schematics	
B.1 Introduction	23
Appendix C. Bill of Materials (BOM)	
C.1 Introduction	31
Worldwide Sales and Service	36

NOTES:

Preface

NOTICE TO CUSTOMERS

All documentation becomes dated, and this manual is no exception. Microchip tools and documentation are constantly evolving to meet customer needs, so some actual dialogs and/or tool descriptions may differ from those in this document. Please refer to our web site (www.microchip.com) to obtain the latest documentation available.

Documents are identified with a “DS” number. This number is located on the bottom of each page, in front of the page number. The numbering convention for the DS number is “DSXXXXA”, where “XXXX” is the document number and “A” is the revision level of the document.

For the most up-to-date information on development tools, see the MPLAB® IDE online help. Select the Help menu, and then Topics to open a list of available online help files.

INTRODUCTION

This chapter contains general information that will be useful to know before using Atlantis. Items discussed in this chapter include:

- [Document Layout](#)
- [Conventions Used in this Guide](#)
- [The Microchip Web Site](#)
- [Development Systems Customer Change Notification Service](#)
- [Customer Support](#)
- [Document Revision History](#)

DOCUMENT LAYOUT

This document describes how to use the EVB-KSZ9477 as a development tool for the Microchip KSZ9477 gigabit Ethernet switch. The manual layout is as follows:

- **Chapter 1. “Overview”** – Shows a brief description of the EVB-KSZ9477.
- **Chapter 2. “Board Details & Configuration”** – Includes details and instructions for using the EVB-KSZ9477.
- **Appendix A. “EVB-KSZ9477 Evaluation Board”** – This appendix shows the EVB-KSZ9477.
- **Appendix B. “KSZ9477 Evaluation Board Schematics”** – This appendix shows the EVB-KSZ9477 schematics.
- **Appendix C. “Bill of Materials (BOM)”** – This appendix includes the EVB-KSZ9477 Bill of Materials (BOM).

CONVENTIONS USED IN THIS GUIDE

This manual uses the following documentation conventions:

DOCUMENTATION CONVENTIONS

Description	Represents	Examples
Arial font:		
Italic characters	Referenced books	<i>MPLAB® IDE User's Guide</i>
	Emphasized text	...is the <i>only</i> compiler...
Initial caps	A window	the Output window
	A dialog	the Settings dialog
	A menu selection	select Enable Programmer
Quotes	A field name in a window or dialog	"Save project before build"
Underlined, italic text with right angle bracket	A menu path	<u>File</u> > <i>Save</i>
Bold characters	A dialog button	Click OK
	A tab	Click the Power tab
N'Rnnnn	A number in verilog format, where N is the total number of digits, R is the radix and n is a digit.	4'b0010, 2'hF1
Text in angle brackets < >	A key on the keyboard	Press <Enter>, <F1>
Courier New font:		
Plain Courier New	Sample source code	#define START
	Filenames	autoexec.bat
	File paths	c:\mcc18\h
	Keywords	_asm, _endasm, static
	Command-line options	-Opa+, -Opa-
	Bit values	0, 1
	Constants	0xFF, 'A'
Italic Courier New	A variable argument	<i>file.o</i> , where <i>file</i> can be any valid filename
Square brackets []	Optional arguments	mcc18 [options] <i>file</i> [options]
Curly brackets and pipe character: { }	Choice of mutually exclusive arguments; an OR selection	errorlevel {0 1}
Ellipses...	Replaces repeated text	var_name [, var_name...]
	Represents code supplied by user	void main (void) { ... }

THE MICROCHIP WEB SITE

Microchip provides online support via our web site at www.microchip.com. This web site is used as a means to make files and information easily available to customers. Accessible by using your favorite Internet browser, the web site contains the following information:

- **Product Support** – Data sheets and errata, application notes and sample programs, design resources, user's guides and hardware support documents, latest software releases and archived software
- **General Technical Support** – Frequently Asked Questions (FAQs), technical support requests, online discussion groups, Microchip consultant program member listing
- **Business of Microchip** – Product selector and ordering guides, latest Microchip press releases, listing of seminars and events, listings of Microchip sales offices, distributors and factory representatives

DEVELOPMENT SYSTEMS CUSTOMER CHANGE NOTIFICATION SERVICE

Microchip's customer notification service helps keep customers current on Microchip products. Subscribers will receive e-mail notification whenever there are changes, updates, revisions or errata related to a specified product family or development tool of interest.

To register, access the Microchip web site at www.microchip.com, click on Customer Change Notification and follow the registration instructions.

The Development Systems product group categories are:

- **Compilers** – The latest information on Microchip C compilers, assemblers, linkers and other language tools. These include all MPLAB C compilers; all MPLAB assemblers (including MPASM assembler); all MPLAB linkers (including MPLINK object linker); and all MPLAB librarians (including MPLIB object librarian).
- **Emulators** – The latest information on Microchip in-circuit emulators. This includes the MPLAB REAL ICE and MPLAB ICE 2000 in-circuit emulators.
- **In-Circuit Debuggers** – The latest information on the Microchip in-circuit debuggers. This includes MPLAB ICD 3 in-circuit debuggers and PICkit 3 debug express.
- **MPLAB IDE** – The latest information on Microchip MPLAB IDE, the Windows Integrated Development Environment for development systems tools. This list is focused on the MPLAB IDE, MPLAB IDE Project Manager, MPLAB Editor and MPLAB SIM simulator, as well as general editing and debugging features.
- **Programmers** – The latest information on Microchip programmers. These include production programmers such as MPLAB REAL ICE in-circuit emulator, MPLAB ICD 3 in-circuit debugger and MPLAB PM3 device programmers. Also included are nonproduction development programmers such as PICSTART Plus and PIC-kit 2 and 3.

CUSTOMER SUPPORT

Users of Microchip products can receive assistance through several channels:

- Distributor or Representative
- Local Sales Office
- Field Application Engineer (FAE)
- Technical Support

Customers should contact their distributor, representative or field application engineer (FAE) for support. Local sales offices are also available to help customers. A listing of sales offices and locations is included in the back of this document.

Technical support is available through the web site at:

<http://www.microchip.com/support>

DOCUMENT REVISION HISTORY

Revision A (April 2017)

- Initial Release of this Document.

Chapter 1. Overview

1.1 INTRODUCTION

The EVB-KSZ9477 evaluation board features the KSZ9477 seven-port managed gigabit Ethernet switch. It has five 10BASE-T_e/100BASE-TX/1000BASE-T physical layer transceivers (PHYs) and associated MAC units, one SGMII and one RGMII interfaces. Ports 1 through 5, with integrated MAC and PHY are connected to RJ45 Ethernet jacks with integrated magnetics. The SGMII interface is connected to a small form-factor pluggable (SFP) transceiver receptacle whereas, the RGMII interface is connected to the SAMA5D36A embedded microprocessor (MPU).

A user can use the on-board MPU for the customized applications such as IEEE 1588, audio-video bridging (AVB) and ring redundancy (DLR & HSR). The board also provides 2Gb (265MB) DDR2 SDRAM and 2Gb (256MB) of NAND flash memory.

The scope of this document is to describe the EVB-KSZ9477 evaluation board setup and corresponding jumper configurations. A simplified block diagram of the board is shown in [Figure 1-1](#).

FIGURE 1-1: EVB-KSZ9477 BLOCK DIAGRAM

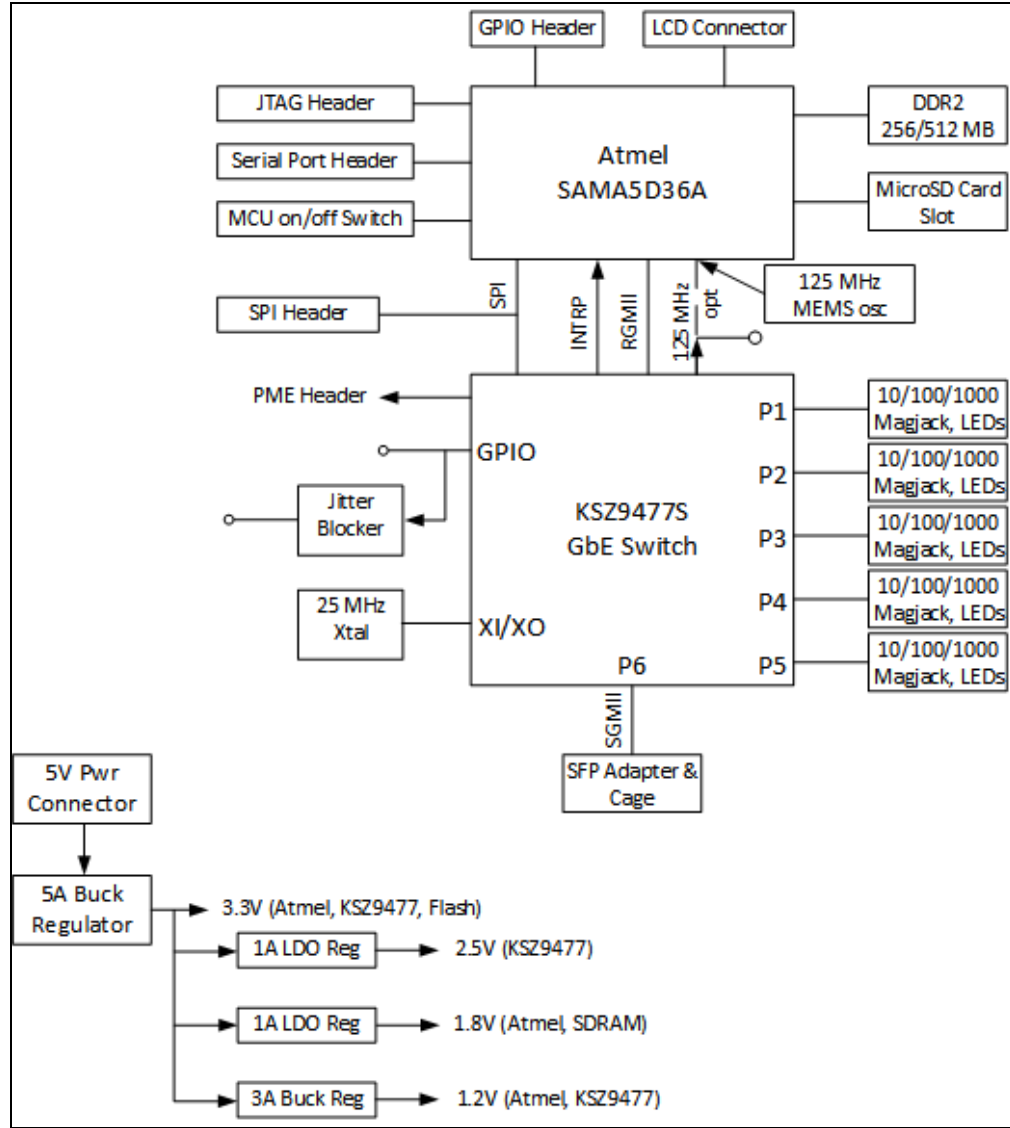

1.2 REFERENCES

Concepts and material available in the following documents will be helpful when reading this document. Visit www.microchip.com for the latest documentation.

- *KSZ9477S Data Sheet*
- *SAMA5D3 Data Sheet*
- *EVB-KSZ9477 Schematic*
- *DSC1101 Data Sheet*
- *ATECC508A Data Sheet*
- *PL902 Data Sheet*

1.3 TERMS AND ABBREVIATIONS

AVB - Audio-Video Bridging

DLR - Device Level Ring

EVB - Evaluation Board

HSR - High Availability Seamless Redundancy

MII - Media Independent Interface

MIIM - Media Independent Interface Management (also known as MDIO/MDC)

RGMII - Reduced Gigabit Media Independent Interface

SPI - Serial Protocol Interface

PHY - Physical Transceiver

SFP - Small Form-factor Pluggable

SGMII - Serial Gigabit Media Independent Interface

NOTES:

Chapter 2. Board Details & Configuration

This section includes sub-sections on the following EVB-KSZ9477 details:

- [Power](#)
- [Resets](#)
- [Clocks](#)
- [Configuration](#)
- [Mechanicals](#)

2.1 POWER

2.1.1 +5V Power

A 5V/2A power supply should be connected to J8 on the board. The SW4 switch must be in the ON position to power the board. The F1 fuse is provided on the board for the over voltage protection.

2.2 RESETS

2.2.1 Power-on Reset

There are two push button switches, SW1 and SW3 available on board. The SW1 switch is a master reset which resets both the MPU and the KSZ9477 Ethernet switch. SW3 resets only the KSZ9477.

2.3 CLOCKS

The evaluation board utilizes a crystal oscillator that provides 25 MHz clock to the KSZ9477 device. The board also features an external clock, DCS1101, which provides 125 MHz 25 ppm clock to the MCU device in the SGMII mode.

2.4 CONFIGURATION

The following sub-sections describe the various board features and configuration settings. A top view of the EVB-KSZ9477 is shown in Figure 2-1.

FIGURE 2-1: EVB-KSZ9477 TOP VIEW WITH CALLOUTS

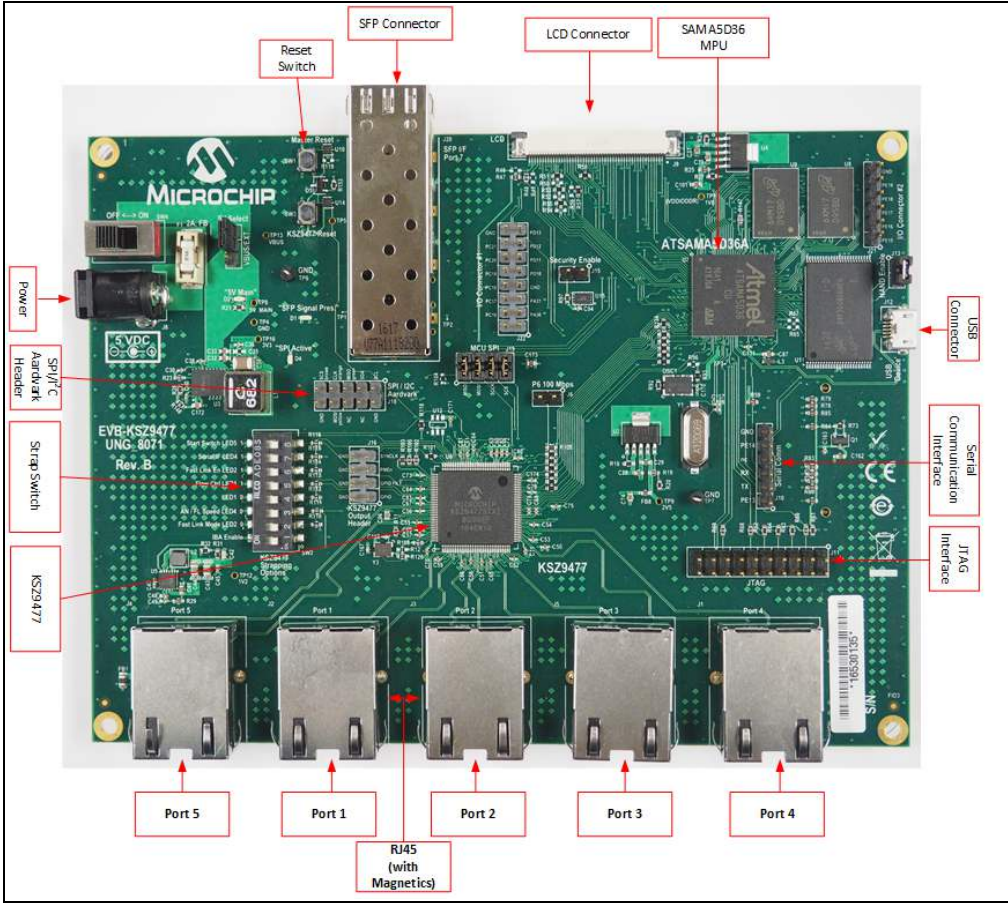

Board Details & Configuration

2.4.1 Switch Settings

SW2 is an eight-position switch which controls many of the KSZ9477 configuration strap options. The KSZ9477 samples these signals at the rising edge of RESET_N to determine some internal settings. Following reset, the configuration of these switches is irrelevant. For initial bring-up, leave most switches in the OFF/OPEN position.

2.4.2 Jumper Settings

Table 2-1, Table 2-2 and Table 2-3 describe jumper settings. The preferred configuration is shown in bold text.

TABLE 2-1: TWO-PIN JUMPERS

Jumper	Label	Description	Open	Closed
J6	P6 100 Mbps	KSZ9477 Port 6 configured for RGMII. This interface is connected to the SAMA5D36 MPU. KSZ9477 Port 6 RGMII speed configuration strap setting. The setting of this jumper takes effect only after reset. This setting must match the speed of the SAMA5D36 RGMII interface.	1000 Mbps	100 Mbps
J15	Security Enable	Enables security chip, ATECC508A to be used with the SAMA5D36 MPU if a user requires to do so.	Disabled (Default)	Enabled
J13	NAND Enable	Enables the NAND flash memory.	Disabled (Default)	Enabled

TABLE 2-2: THREE-PIN JUMPERS

Jumper	Label	Description	Jumper 1-2	Jumper 2-3
J7	5 VDC	Board power source: 5V barrel connector or USB	Power from barrel jack	USB powered. Not recommended due to high current requirement.

TABLE 2-3: MULTI-PIN HEADERS

Jumper	Label	Description	Configuration
J16	KSZ9477 Output Header	KSZ9477 output probe points, 4x2 header	Do not install jumpers. Pin 1: GPIO Pin 3: GPIO output filtered by PL902 JitterBlocker. Pin 5: PME_N output Pin 7: SYNCLK - 25MHz or 125MHz output reference clock
J21	I/O Connector #2	I/O connector for the MPU, 6X1 header	No jumpers.
J10	Serial Communication	Header used for the MPU serial communication, 8x1 header	No jumpers. It is recommended to use the TTL-232R-3V3 cable from FTDI.
J18	SPI/I ² C Aardvark	KSZ9477 SPI/I ² C header for external access 5x2 header	An Aardvark SPI/I ² C adapter can be attached.

TABLE 2-3: MULTI-PIN HEADERS

Jumper	Label	Description	Configuration
J11	JTAG	JTAG interface to program and debug the MPU, 10X2 header	No jumpers
J22	I/O Connector #1	GPIO for the MPU	No jumpers
J9	LCD connector	LCD connector for the MPU	No jumpers. Refer to <i>SAMA5D3 Xplained User Guide</i> for details.

2.4.3 SPI and I²C

The MPU can control the KSZ9477 via the SPI interface or an external device such as, Totalphase Aardvark. The [Table 2-4](#) below explains the jumper settings.

TABLE 2-4: SPI/I²C HEADER

Mode	J18 (5X2 header)	J19 (4X2 header)
SPI from Atmel MCU	All open	Install all jumpers
SPI from Aardvark or Cheetah cable	Connect Aardvark or Cheetah cable	All open
SPI from Aardvark I ² C/SPI host adapter or Cheetah SPI host adapter	Connect Aardvark	All open

Note: Both the adapters are available on MicrochipDirect.com web site to purchase. SPI from Aardvark I²C/SPI (part number TTP100005) or Cheetah SPI host adapter (part number TTP100004).

2.4.4 LED Status

The table [Table 2-5](#) shows the LED status indication.

TABLE 2-5: STATUS LEDES

Item	LED Diode	Comments
1.	D1 (Green)	SFP Signal present
2.	D2 (Green)	3.3V Power indication
3.	D4 (Blue)	SPI Active

2.5 MECHANICALS

FIGURE 2-2: EVB-KSZ9477 MECHANICAL DIMENSIONS

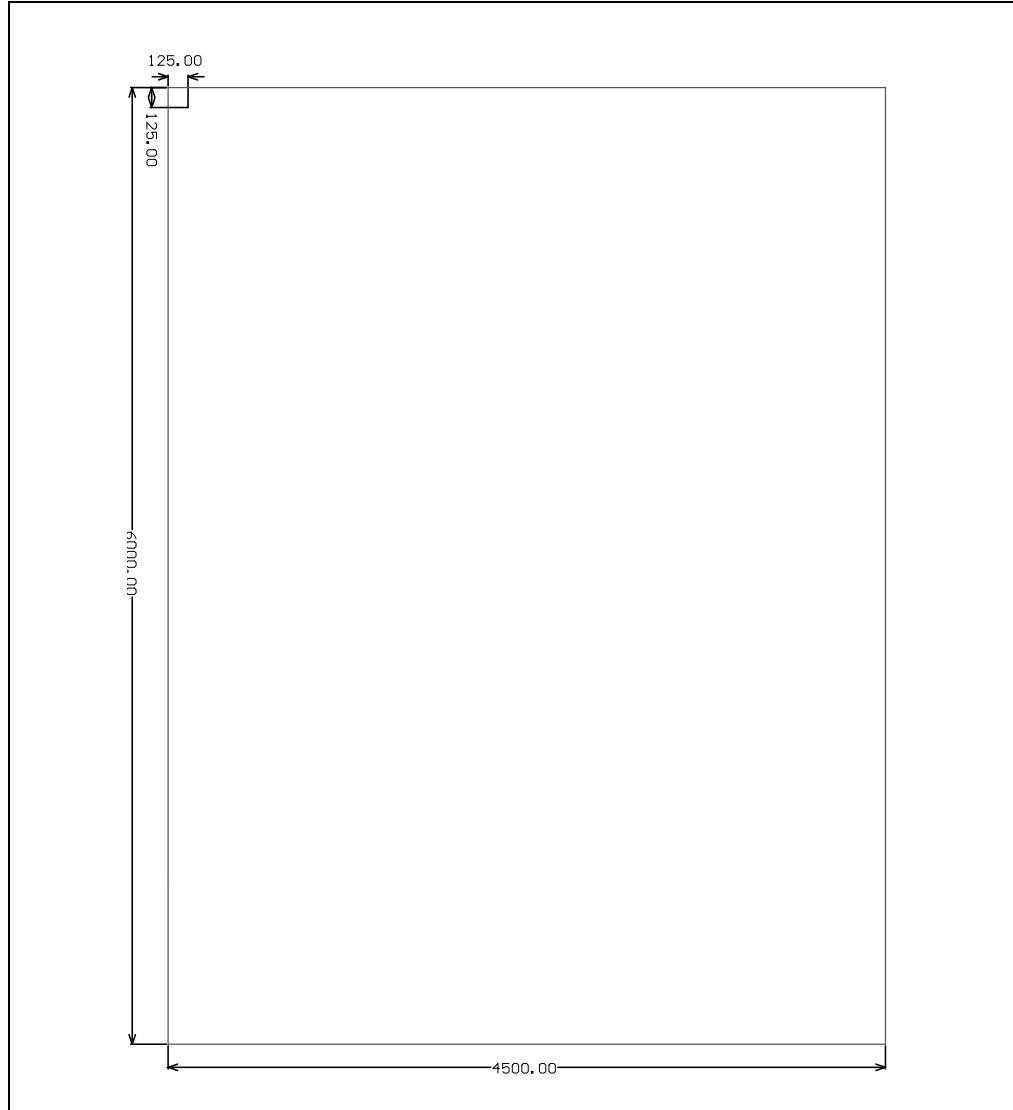

NOTES:

Appendix A. EVB-KSZ9477 Evaluation Board

A.1 INTRODUCTION

This appendix shows the EVB-KSZ9477 Evaluation Board.

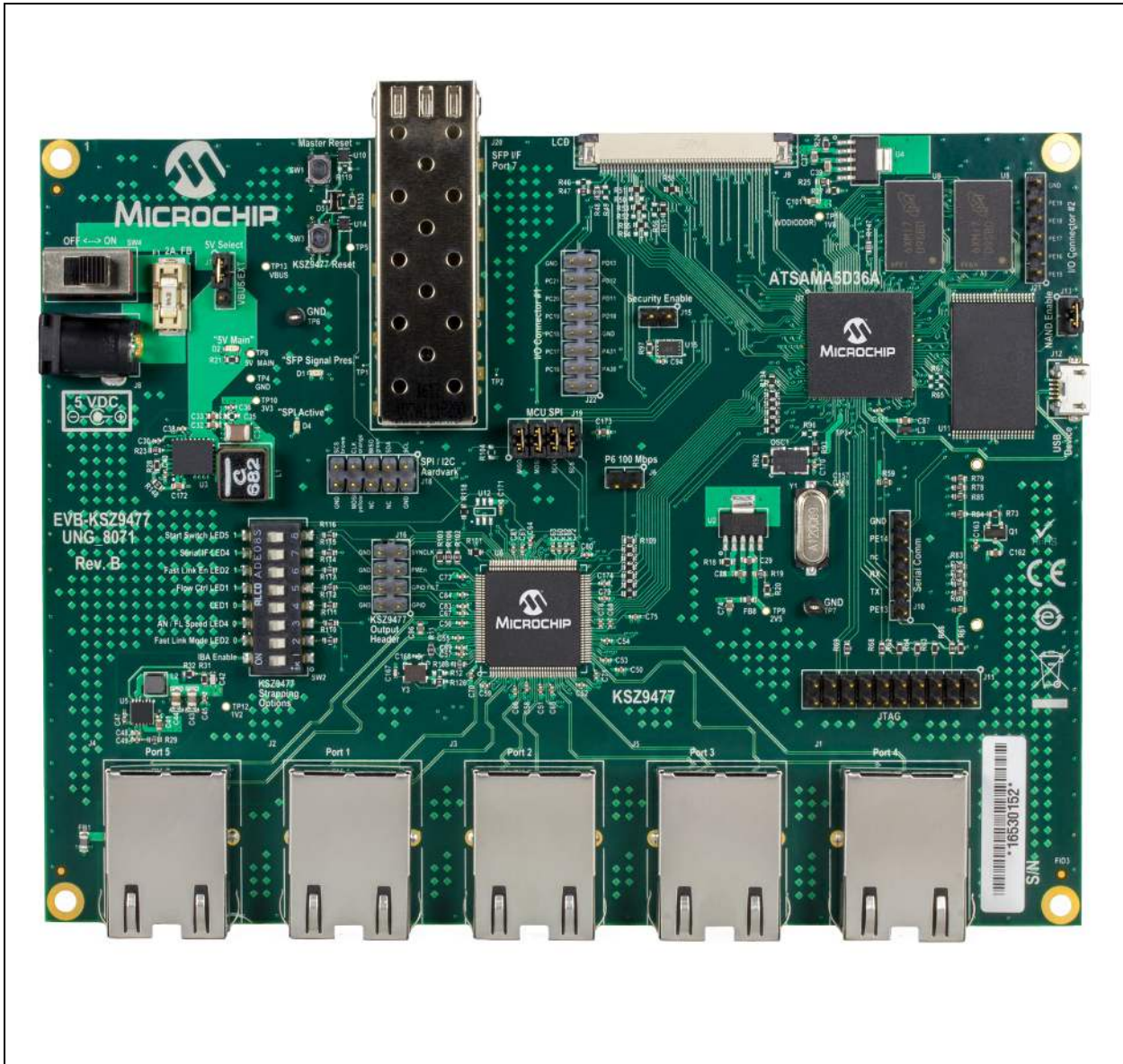
FIGURE A-1: EVB-KSZ9477 EVALUATION BOARD

NOTES:



Appendix B. KSZ9477 Evaluation Board Schematics

B.1 INTRODUCTION

This appendix shows the EVB-KSZ9477 Evaluation Board Schematics.

FIGURE B-1: EVB-KSZ9477 BOARD POWER I/O AND REGULATORS

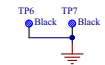
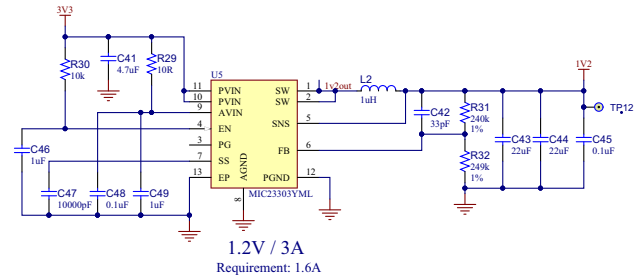
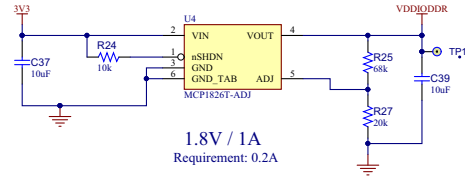
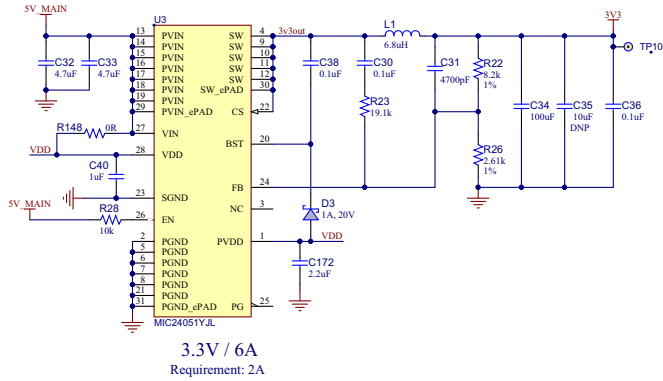
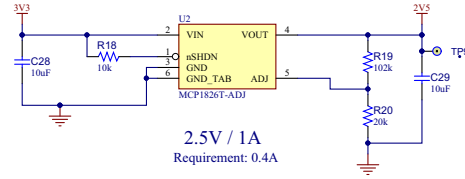
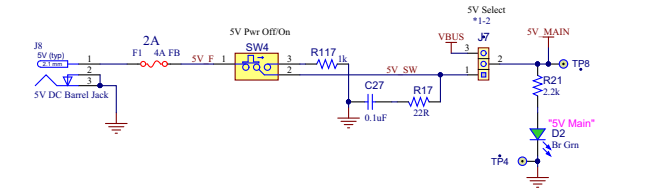
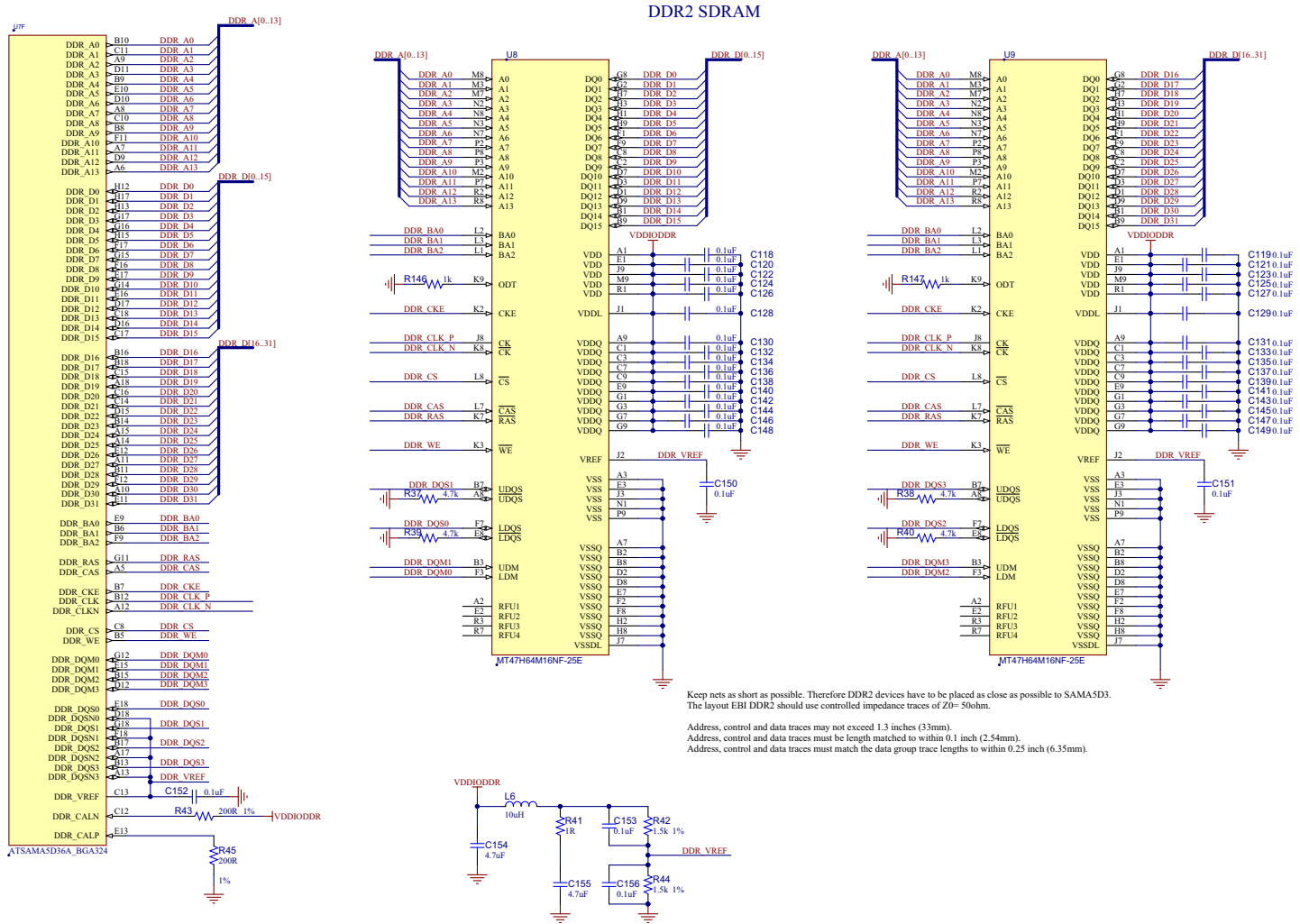

FIGURE B-2: EVB-KSZ9477 DDR2 SDRAM



Keep nets as short as possible. Therefore DDR2 devices have to be placed as close as possible to SAM5D3. The layout EBI DDR2 should use controlled impedance traces of Z0 = 50ohm.

Address, control and data traces may not exceed 1.3 inches (33mm).
 Address, control and data traces must be length matched to within 0.1 inch (2.54mm).
 Address, control and data traces must match the data group trace lengths to within 0.25 inch (6.35mm).

FIGURE B-3: EVB-KSZ9477 ETHERNET PORT AND SGMII SFP

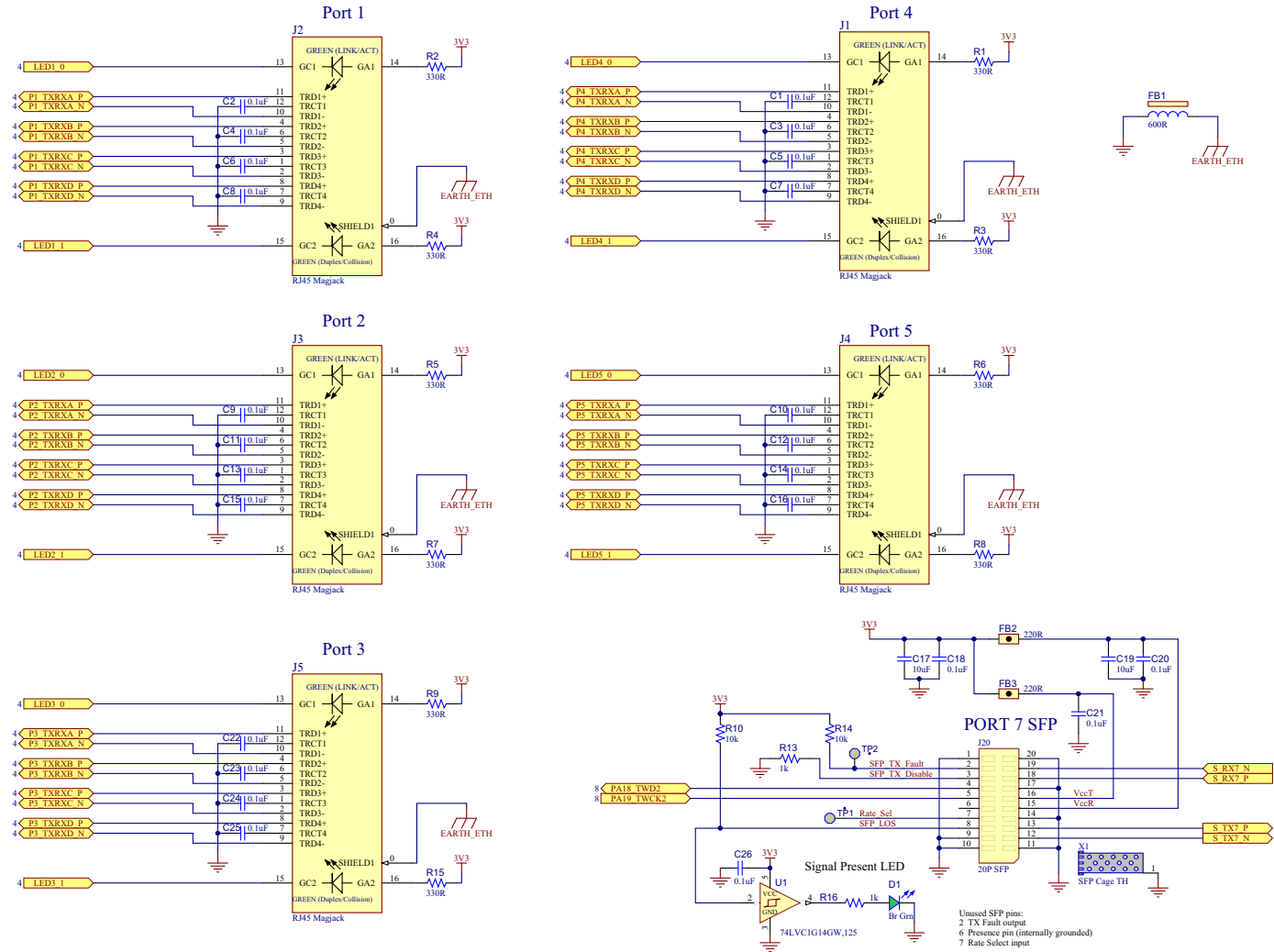

FIGURE B-4: EVB-KSZ9477 SCHEMATIC - KSZ9477 RGMII TO SAMA5D3

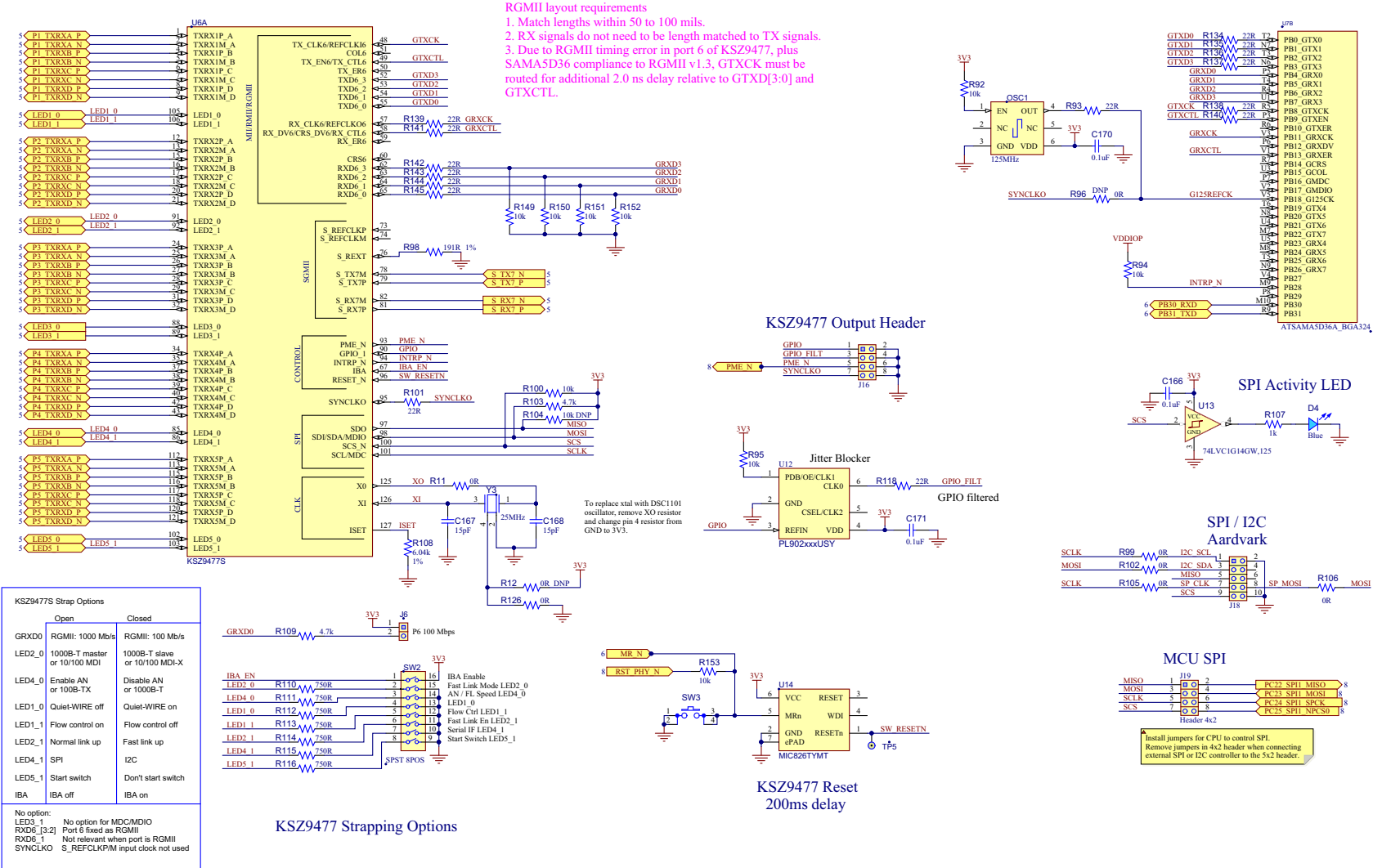

FIGURE B-5: EVB-KSZ9477 POWER CONNECTIONS FOR SWITCH AND SOC

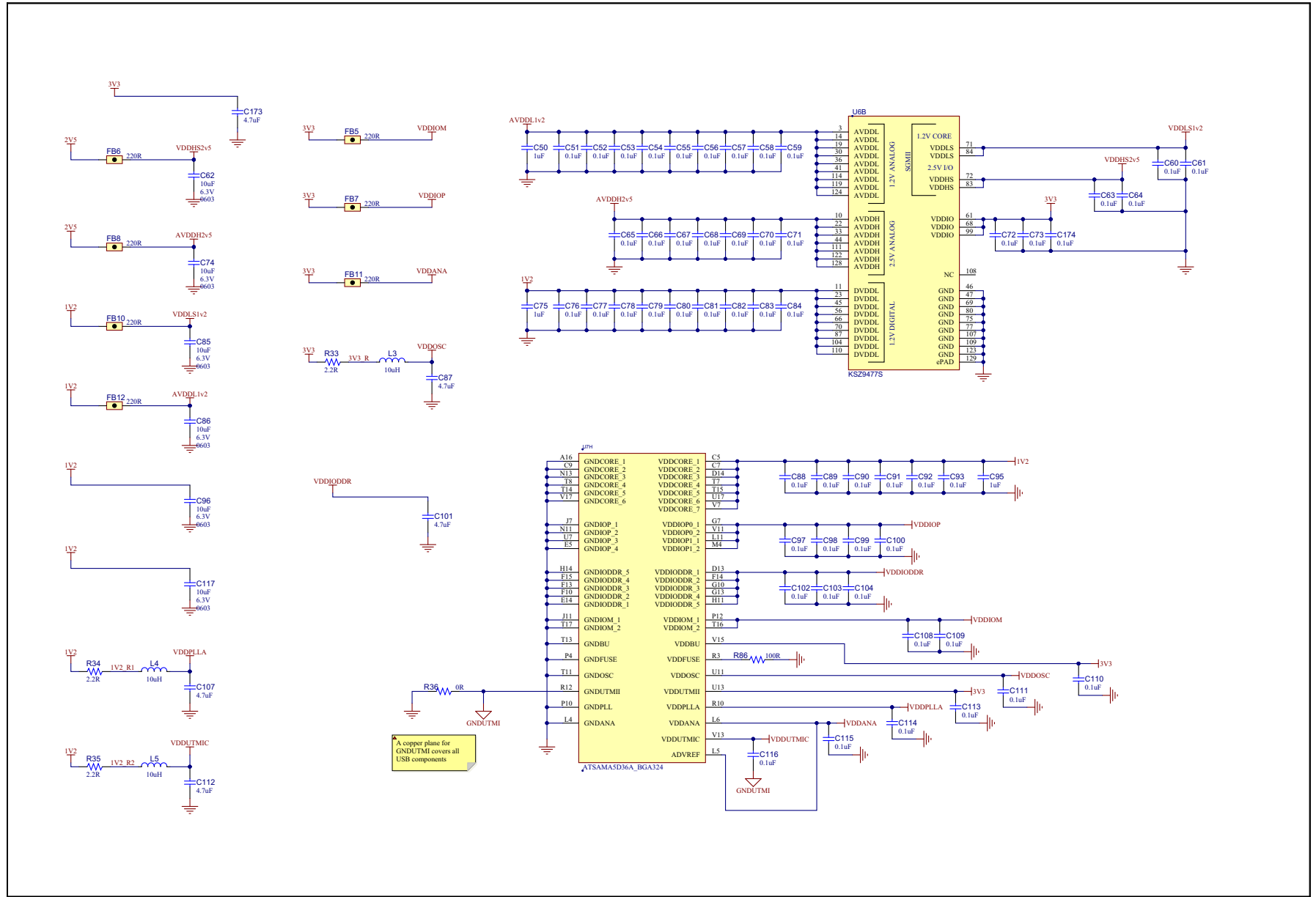

FIGURE B-6: EVB-KSZ9477 SOC CORE CONNECTIONS NAND FLASH SD CARD

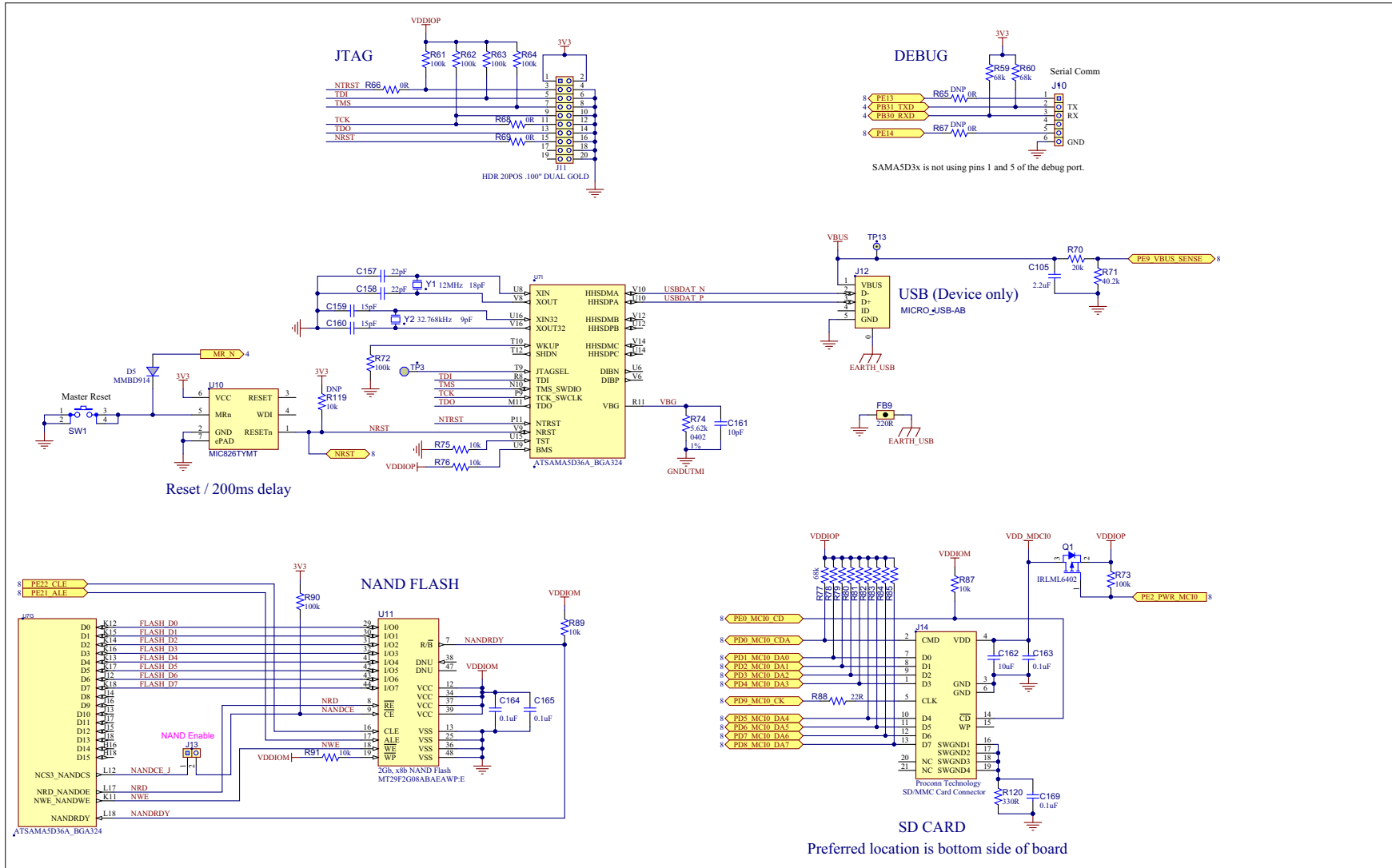
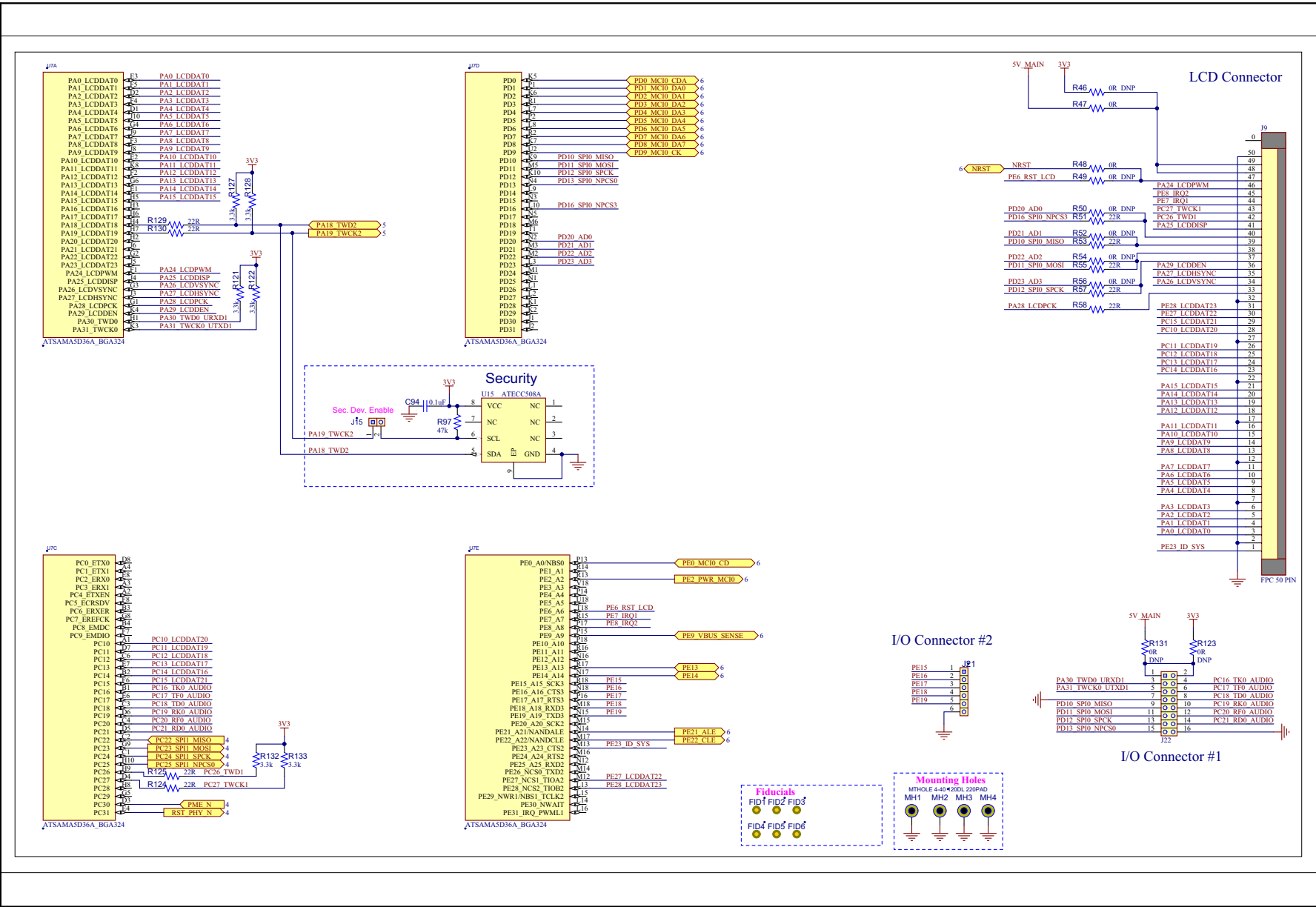

FIGURE B-7: EVB-KSZ9477 SOC GPIO LCD CONNECTOR MISC HEADER





Appendix C. Bill of Materials (BOM)

C.1 INTRODUCTION

This appendix includes the EVB-KSZ9477 Evaluation Board Bill of Materials (BOM).

TABLE C-1: BILL OF MATERIALS

Item	Qty	Reference	Description	Populated	Manufacturer	Manufacturer Part Number
1	126	C1, C2, C3, C4, C5, C6, C7, C8, C9, C10, C11, C12, C13, C14, C15, C16, C18, C20, C21, C22, C23, C24, C25, C26, C30, C36, C38, C45, C48, C51, C52, C53, C54, C55, C56, C57, C58, C59, C60, C61, C63, C64, C65, C66, C67, C68, C69, C70, C71, C72, C73, C76, C77, C78, C79, C80, C81, C82, C83, C84, C88, C89, C90, C91, C92, C93, C97, C98, C99, C100, C102, C103, C104, C108, C109, C110, C111, C113, C114, C115, C116, C118, C119, C120, C121, C122, C123, C124, C125, C126, C127, C128, C129, C130, C131, C132, C133, C134, C135, C136, C137, C138, C139, C140, C141, C142, C143, C144, C145, C146, C147, C148, C149, C150, C151, C152, C153, C156, C163, C164, C165, C166, C169, C170, C171, C174	CAP CER 0.1uF 50V 10% X7R SMD 0402	YES	TDK Corporation	C1005X7R1H104K050BB
2	13	C17, C19, C28, C29, C37, C39, C62, C74, C85, C86, C96, C117, C162	CAP CER 10uF 6.3V 20% X5R SMD 0603	YES	AVX	06036D106MAT2A
3	2	C27, C94	CAP CER 0.1uF 50V 10% X7R SMD 0402	YES	TDK Corporation	C1005X7R1H104K050BB
4	1	C31	CAP CER 4700pF 16V 10% X7R SMD 0402	YES	Murata Electronics North America	GRM155R71C472KA01D
5	10	C32, C33, C41, C87, C101, C107, C112, C154, C155, C173	CAP CER 4.7uF 16V 10% X5R SMD 0603	YES	TDK Corporation	C1608X5R1C475K080AC
6	1	C34	CAP CER 100uF 6.3V 20% X5R SMD 1210	YES	TDK Corporation	C3225X5R0J107M250AC
7	6	C40, C46, C49, C50, C75, C95	CAP CER 1uF 16V 10% X5R SMD 0402	YES	TDK Corporation	C1005X5R1C105K
8	1	C42	CAP CER 33pF 50V 5% NP0 SMD 0603	YES	Cal-Chip	GMC10CG330J50NTLF
9	2	C43, C44	CAP CER 22uF 16V 10% X5R SMD 0805	YES	TDK	C2012X5R1C226K
10	1	C47	CAP CER 10000pF 16V 10% X7R SMD 0402	YES	KEMET	C0402C103K4RACTU
11	2	C105, C172	CAP CER 2.2uF 16V 10% X5R SMD 0603	YES	TDK	C1608X5R1C225K
12	2	C157, C158	CAP CER 22pF 50V 5% NP0 SMD 0402	YES	Murata	GRM1555C1H220JZ01D
13	4	C159, C160, C167, C168	CAP CER 15pF 50V 5% NP0 SMD 0402	YES	Murata	GRM1555C1H150JA01D
14	1	C161	CAP CER 10pF 50V 5% NP0 SMD 0402	YES	Murata	GRM1555C1H100JZ01D
15	2	D1, D2	LED, Bright Green, 0603	YES	Lite-On	LTST-C191KGKT
16	1	D3	DIODE SCHOTTKY 20V 1A SOD523	YES	NXP USA Inc.	PMEG2010AEB,115
17	1	D4	LED, Blue, 0603	YES	Kingbright	APT1608VBC/D
18	1	D5	DIO RECT MMBD914LT1G 1V 10mA 100V SMD SOT-23-3	YES	ON Semiconductor	MMBD914LT1G
19	1	F1	FUSE BRD MNT 4A 125VAC/VDC 2SMD	YES	Littlefuse	0154004.DR
20	1	FB1	FERRITE 2A 600R SMD 0805	YES	TDK Corporation	MPZ2012S601AT000
21	10	FB2, FB3, FB5, FB6, FB7, FB8, FB9, FB10, FB11, FB12	FERRITE 220R @ 100MHz 2A SMD 0603	YES	Murata Electronics North America	BLM18EG221SN1D

TABLE C-1: BILL OF MATERIALS (CONTINUED)

Item	Qty	Reference	Description	Populated	Manufacturer	Manufacturer Part Number
22	5	J1, J2, J3, J4, J5	CON MODULAR RJ45 MAGJACK TH R/A	YES	Amphenol Commercial Products	RJMG2012211A0FR
23	3	J6, J13, J15	CON HDR-2.54 MALE 1x2 GOLD 5.84MH TH VERT	YES	Hdr	Hdr-1x36 (FCI, 68000-236HL)
24	1	J7	HDR 3POS .100" SGL GOLD	YES	Hdr	Hdr-1x36 (FCI, 68000-236HL)
25	1	J8	CONN PWR JACK 2.5X5.5MM HIGH CUR	YES	CUI Inc.	PJ-002AH
26	1	J9	CON FPC 687 0.5MM 50P FEMALE SMD R/A	YES	WURTH	68715014022
27	2	J10, J21	CON HDR-2.54 MALE 1x6 GOLD 5.84MH TH VERT	YES	Hdr	Hdr-1x36 (FCI, 68000-236HL)
28	1	J11	HDR 20POS .100" DUAL GOLD	YES	Hdr	Make from Hdr-2x36 (FCI, 67996-272HLF)
29	1	J12	MICRO_USB-AB	YES	JAE Electronics	DX4R205JJAR1800
30	2	J16, J19	CON HDR-2.54 Male 2x3 Gold 5.84MH TH VERT	YES	Hdr	Make from Hdr-2x36 (FCI, 67996-272HLF)
31	1	J18	Header, 5-Pin, Dual row	YES	Hdr	Make from Hdr-2x36 (FCI, 67996-272HLF)
32	1	J20	CON SFP 136 0.80MM 20P Female SMD R/A	YES	TE Connectivity AMP Connectors	1367073-1
33	1	J22	HDR 16POS .100" DUAL GOLD	YES	Hdr	Make from Hdr-2x36 (FCI, 67996-272HLF)
34	1	L1	INDUCTOR 6.8uH 9.2A 20% XAL7070-682MEC SMD	YES	Coilcraft	XAL7070-682MEC
35	1	L2	INDUCTOR 1uH 2.1A 30% SMD L3W3H1.5	YES	Taiyo Yuden	NR3015T1R0N
36	4	L3, L4, L5, L6	INDUCTOR 10uH 80mA 10% SMD 0603	YES	Taiyo Yuden	LBMF1608T100K
37	1	Q1	TRANS FET P-CH IRLML6402 -20V -3.7A 1.3W SOT-23-3	YES	International Rectifier	IRLML6402TRPBF
38	11	R1, R2, R3, R4, R5, R6, R7, R8, R9, R15, R120	RES TKF 330R 5% 1/10W SMD 0603	YES	Panasonic	ERJ-3GEYJ331V
39	20	R10, R14, R18, R24, R28, R30, R75, R76, R87, R89, R91, R92, R94, R95, R100, R149, R150, R151, R152, R153	RES TKF 10k 1% 1/10W SMD 0603	YES	Panasonic	ERJ-3EKF1002V
40	12	R11, R36, R47, R48, R66, R68, R69, R99, R102, R105, R106, R126	RES TKF 0R 1/10W SMD 0603	YES	Panasonic	ERJ-3GSY0R00V
41	5	R13, R16, R107, R146, R147	RES TKF 1k 5% 1/10W SMD 0603	YES	Panasonic	ERJ-3GEYJ102V
42	1	R17	RES TKF 22R 1% 1/10W SMD 0603	YES	Yageo	RC0603FR-0722RL
43	1	R19	RES TKF 102k 1/10W 1% SMD 0603	YES	Stackpole Electronics Inc	RMCF0603FT102K
44	3	R20, R27, R70	RES TKF 20k 1% 1/10W SMD 0603	YES	Panasonic	ERJ-3EKF2002V
45	1	R21	RES TKF 2.2k 1% 1/10W SMD 0603	YES	Panasonic	ERJ-3EKF2201V
46	1	R22	RES TKF 8.2k 1% 1/10W SMD 0603	YES	Panasonic	ERJ-3EKF8201V
47	1	R23	RES TKF 19.1k 1% 1/10W SMD 0603	YES	Yageo	RC0603FR-0719K1L

TABLE C-1: BILL OF MATERIALS (CONTINUED)

Item	Qty	Reference	Description	Populated	Manufacturer	Manufacturer Part Number
48	12	R25, R59, R60, R77, R78, R79, R80, R81, R82, R83, R84, R85	RES TKF 68k 1% 1/10W SMD 0603	YES	Stackpole Electronics Inc	RMCF0603FT68K0
49	1	R26	RES TKF 2.61k 1% 1/16W SMD 0603	YES	MULTICOMP	MC 0.063W 0603 1% 2K61
50	1	R29	RES TKF 10R 1% 1/10W SMD 0603	YES	Stackpole Electronics Inc	RMCF0603FT10R0
51	1	R31	RES TKF 240k 1% 1/10W SMD 0603	YES	Panasonic Electronic Components	ERJ-3EKF2403V
52	1	R32	RES TKF 249k 1% 1/10W SMD 0603	YES	Panasonic	ERJ-3EKF2493V
53	3	R33, R34, R35	RES TKF 2.2R 5% 1/10W SMD 0603	YES	Stackpole Electronics Inc	RMCF0603JT2R20
54	6	R37, R38, R39, R40, R103, R109	RES TKF 4.7k 1% 1/10W SMD 0603	YES	ROHM	MCR03EZPFX4701
55	1	R41	RES TKF 1R 1% 1/10W SMD 0603	YES	Yageo	RC0603FR-071RL
56	2	R42, R44	RES TKF 1.5k 1% 1/10W SMD 0603	YES	Panasonic	ERJ-3EKF1501V
57	2	R43, R45	RES TKF 200R 1% 1/10W SMD 0603	YES	Yageo	RC0603FR-07200RL
58	25	R51, R53, R55, R57, R58, R88, R93, R101, R118, R124, R125, R129, R130, R134, R135, R136, R137, R138, R139, R140, R141, R142, R143, R144, R145	RES TKF 22R 1% 1/10W SMD 0603	YES	Yageo	RC0603FR-0722RL
59	7	R61, R62, R63, R64, R72, R73, R90	RES TKF 100k 1% 1/10W SMD 0603	YES	Panasonic	ERJ-3EKF1003V
60	1	R71	RES TKF 40.2k 1% 1/10W SMD 0603	YES	Yageo	RC0603FR-0740K2L
61	1	R74	RES TKF 5.62k 1% 1/16W SMD 0402	YES	Vishay Dale	CRCW04025K62FKED
62	1	R86	RES TKF 100R 1% 1/10W SMD 0603	YES	ROHM	MCR03EZPFX1000
63	1	R97	RES TKF 47k 1% 1/10W SMD 0603	YES	Panasonic	ERJ-3EKF4702V
64	1	R98	RES TKF 191R 1% 1/10W SMD 0603	YES	Yageo	RC0603FR-07191RL
65	1	R108	RES TKF 6.04k 1% 1/10W SMD 0603	YES	Yageo	9T06031A6041FBHFT
66	7	R110, R111, R112, R113, R114, R115, R116	RES TKF 750R 1% 1/10W SMD 0603	YES	Vishay	CRCW0603750RFKEA
67	1	R117	RES TKF 1k 1% 1/10W SMD 0603	YES	Panasonic	ERJ-3EKF1001V
68	6	R121, R122, R127, R128, R132, R133	RES TKF 3.3k 5% 1/10W SMD 0603	YES	Panasonic	ERJ-3GSYJ332V
69	1	R148	RES TKF 0R 1/10W SMD 0603	YES	Panasonic	ERJ-3GSY0R00V
70	2	SW1, SW3	Switch, Tactile, SPST, 50mA, 16VDC, J-lead, 4.2 x 3.2 mm, PTS810, NO	YES	C&K	PTS810 SJM 250 SMTR LFS
71	1	SW2	SWITCH SLIDE SPST 24V 100mA 1825058-9EXT ACT 8POS 24V	YES	TE Connectivity Alcoswitch Switches	1-1825058-9
72	1	SW4	SWITCH SLIDE SPDT 120V 6A 1101M2S3CQE2 TH	YES	C&K Components	1101M2S3CQE2
73	2	TP6, TP7	TEST POINT PC MINI .040"D BLACK	YES	Keystone Electronics	5001
74	2	U1, U13	74LVC1G14GW,125 SCHMITT-TRG INVERTER	YES	NXP	74LVC1G14GW,125
75	2	U8, U9	IC DDR2 SDRAM 1GBIT 2.5NS 84FBGA	YES	Micron Technology Inc.	MT47H64M16NF-25E:M
76	1	U11	IC, MT29F2G08ABAE, Rev. E, NAND Flash, 2Gb, x8b, TSOP48	YES	Micron Technology Inc.	MT29F2G08ABAEAWP:E TR
77	1	X1	Cage, SFP, Amphenol, U77-A1118-200 (-1 or -T)	YES	Amphenol	U77-A1118-2001

TABLE C-1: BILL OF MATERIALS (CONTINUED)

Item	Qty	Reference	Description	Populated	Manufacturer	Manufacturer Part Number
78	1	Y1	CRYSTAL 12MHz 18pF SMD HC49/US	YES	Abracon	ABLS-12.000MHZ-B4-T
79	1	Y2	32.768kHz ±20ppm Crystal 9pF 70 kOhm -40°C ~ 85°C Surface Mount 2-SMD	YES	NDK	NX3215SA-32.768K-STD-MUA-9
80	1	Y3	Crystal 25MHz 6pF SMD 4Pin DFN LCC	YES	Murata Electronics North America	ABM8G-25.000MHZ-B4Y-T
81	1	J14	Connector, SD/MMC, Push-Pull, RA, SMD, 15 pin+4 shield	YES	Proconn Technology	SDC013-A0-5002
82	1	OSC1	OSC MEMS 125.000MHZ CMOS SMD	YES	Microchip/Micrel	DSC1101BI2-125.0000
83	2	U2, U4	IC REG LDO ADJ 1A SOT223-6	YES	MICROCHIP	MCP1826T-ADJE/DC
84	1	U3	IC REG BUCK ADJ 6A SYNC 28QFN	YES	Microchip/Micrel	MIC24051YJL
85	1	U5	4MHz PWM 3A Buck Regulator with HyperLight Load and Power Good	YES	Microchip Technology	MIC23303YML
86	1	U6	IC, 7-Port Gigabit Ethernet Switch with 2 RGMII / MII / RMII Interfaces, TQFP128	YES	Microchip/Micrel	KSZ9477S
87	1	U7	IC, ARM Cortex A5 MPU, 32-bit, 536MHz, 1.2V, 324BGA	YES	Microchip/Atmel	ATSAMA5D36A-CU
88	2	U10, U14	IC SUPERVISOR RESET 3.075V 6TDFN	YES	Microchip/Micrel	MIC826TYMT
89	1	U12	IC JITTER ATTEN	YES	Microchip/Micrel Inc	PL902xxxUSY
90	1	U15	IC INTERFACE ATECC508A UDFN-8	YES	Microchip/Atmel	ATECC508A-MAHDA-T
91	0	C35	CAP CER 10uF 6.3V 20% X5R SMD 0603	NO	AVX	06036D106MAT2A
92	0	R12, R46, R49, R50, R52, R54, R56, R65, R67, R96, R123, R131	RES TKF 0R 1/10W SMD 0603	NO	Panasonic	ERJ-3GSY0R00V
93	0	R104, R119	RES TKF 10k 1% 1/10W SMD 0603	NO	Panasonic	ERJ-3EKF1002V



MICROCHIP

Worldwide Sales and Service

AMERICAS

Corporate Office
2355 West Chandler Blvd.
Chandler, AZ 85224-6199
Tel: 480-792-7200
Fax: 480-792-7277
Technical Support:
<http://www.microchip.com/support>
Web Address:
www.microchip.com

Atlanta
Duluth, GA
Tel: 678-957-9614
Fax: 678-957-1455

Austin, TX
Tel: 512-257-3370

Boston
Westborough, MA
Tel: 774-760-0087
Fax: 774-760-0088

Chicago
Itasca, IL
Tel: 630-285-0071
Fax: 630-285-0075

Dallas
Addison, TX
Tel: 972-818-7423
Fax: 972-818-2924

Detroit
Novi, MI
Tel: 248-848-4000

Houston, TX
Tel: 281-894-5983

Indianapolis
Noblesville, IN
Tel: 317-773-8323
Fax: 317-773-5453
Tel: 317-536-2380

Los Angeles
Mission Viejo, CA
Tel: 949-462-9523
Fax: 949-462-9608
Tel: 951-273-7800

Raleigh, NC
Tel: 919-844-7510

New York, NY
Tel: 631-435-6000

San Jose, CA
Tel: 408-735-9110
Tel: 408-436-4270

Canada - Toronto
Tel: 905-695-1980
Fax: 905-695-2078

ASIA/PACIFIC

Asia Pacific Office
Suites 3707-14, 37th Floor
Tower 6, The Gateway
Harbour City, Kowloon

Hong Kong
Tel: 852-2943-5100
Fax: 852-2401-3431

Australia - Sydney
Tel: 61-2-9868-6733
Fax: 61-2-9868-6755

China - Beijing
Tel: 86-10-8569-7000
Fax: 86-10-8528-2104

China - Chengdu
Tel: 86-28-8665-5511
Fax: 86-28-8665-7889

China - Chongqing
Tel: 86-23-8980-9588
Fax: 86-23-8980-9500

China - Dongguan
Tel: 86-769-8702-9880

China - Guangzhou
Tel: 86-20-8755-8029

China - Hangzhou
Tel: 86-571-8792-8115
Fax: 86-571-8792-8116

China - Hong Kong SAR
Tel: 852-2943-5100
Fax: 852-2401-3431

China - Nanjing
Tel: 86-25-8473-2460
Fax: 86-25-8473-2470

China - Qingdao
Tel: 86-532-8502-7355
Fax: 86-532-8502-7205

China - Shanghai
Tel: 86-21-3326-8000
Fax: 86-21-3326-8021

China - Shenyang
Tel: 86-24-2334-2829
Fax: 86-24-2334-2393

China - Shenzhen
Tel: 86-755-8864-2200
Fax: 86-755-8203-1760

China - Wuhan
Tel: 86-27-5980-5300
Fax: 86-27-5980-5118

China - Xian
Tel: 86-29-8833-7252
Fax: 86-29-8833-7256

ASIA/PACIFIC

China - Xiamen
Tel: 86-592-2388138
Fax: 86-592-2388130

China - Zhuhai
Tel: 86-756-3210040
Fax: 86-756-3210049

India - Bangalore
Tel: 91-80-3090-4444
Fax: 91-80-3090-4123

India - New Delhi
Tel: 91-11-4160-8631
Fax: 91-11-4160-8632

India - Pune
Tel: 91-20-3019-1500

Japan - Osaka
Tel: 81-6-6152-7160
Fax: 81-6-6152-9310

Japan - Tokyo
Tel: 81-3-6880-3770
Fax: 81-3-6880-3771

Korea - Daegu
Tel: 82-53-744-4301
Fax: 82-53-744-4302

Korea - Seoul
Tel: 82-2-554-7200
Fax: 82-2-558-5932 or
82-2-558-5934

Malaysia - Kuala Lumpur
Tel: 60-3-6201-9857
Fax: 60-3-6201-9859

Malaysia - Penang
Tel: 60-4-227-8870
Fax: 60-4-227-4068

Philippines - Manila
Tel: 63-2-634-9065
Fax: 63-2-634-9069

Singapore
Tel: 65-6334-8870
Fax: 65-6334-8850

Taiwan - Hsin Chu
Tel: 886-3-5778-366
Fax: 886-3-5770-955

Taiwan - Kaohsiung
Tel: 886-7-213-7830

Taiwan - Taipei
Tel: 886-2-2508-8600
Fax: 886-2-2508-0102

Thailand - Bangkok
Tel: 66-2-694-1351
Fax: 66-2-694-1350

EUROPE

Austria - Wels
Tel: 43-7242-2244-39
Fax: 43-7242-2244-393

Denmark - Copenhagen
Tel: 45-4450-2828
Fax: 45-4485-2829

Finland - Espoo
Tel: 358-9-4520-820

France - Paris
Tel: 33-1-69-53-63-20
Fax: 33-1-69-30-90-79

France - Saint Cloud
Tel: 33-1-30-60-70-00

Germany - Garching
Tel: 49-8931-9700

Germany - Haan
Tel: 49-2129-3766400

Germany - Heilbronn
Tel: 49-7131-67-3636

Germany - Karlsruhe
Tel: 49-721-625370

Germany - Munich
Tel: 49-89-627-144-0
Fax: 49-89-627-144-44

Germany - Rosenheim
Tel: 49-8031-354-560

Israel - Ra'anana
Tel: 972-9-744-7705

Italy - Milan
Tel: 39-0331-742611
Fax: 39-0331-466781

Italy - Padova
Tel: 39-049-7625286

Netherlands - Drunen
Tel: 31-416-690399
Fax: 31-416-690340

Norway - Trondheim
Tel: 47-7289-7561

Poland - Warsaw
Tel: 48-22-3325737

Romania - Bucharest
Tel: 40-21-407-87-50

Spain - Madrid
Tel: 34-91-708-08-90
Fax: 34-91-708-08-91

Sweden - Gothenberg
Tel: 46-31-704-60-40

Sweden - Stockholm
Tel: 46-8-5090-4654

UK - Wokingham
Tel: 44-118-921-5800
Fax: 44-118-921-5820