

Low profile, PCB Relay T75 Series

- 1 pole 8A, 1 form C (CO) or 1 form A (NO) contact
- 4kV/8mm coil-contact
- Reinforced insulation (protection classII)
- Ambient temperature up to 85°C at 8A
- Plastic materials according to IEC60335-1 (domestic appliances)

Typical applications
HVAC, security and industrial control, domestic appliances.

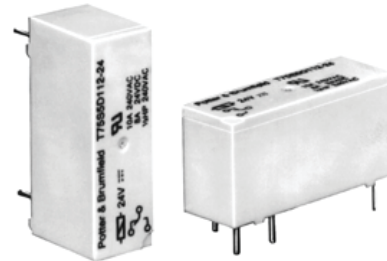

Approvals

VDE Cert. No. 3919, UL E214025
Technical data of approved types on request.

Contact Data

Contact arrangement	1 form C (CO) or 1 form A (NO)
Rated voltage	250VAC
Max. switching voltage	400VAC
Rated current	8A
Limiting making current, max 4s, df 10%	15A
Breaking capacity max.	2000VA
Contact material	AgCdO
Min. recommended contact load	100mA at 12VDC
Minimum switching voltage	5VDC
Initial contact resistance	100mΩ at 100mA, 12VDC
Frequency of operation, with/without load	6/1200min ⁻¹
Operate/release time max.	10/5ms
Bounce time max., form A/form B	3/10ms

Electrical endurance

Type	Contact	Load	Cycles
T75		8Arms, 240VAC, resistive	100x10 ³
T75	A (NO)	14Arms, 120VAC, resistive	50x10 ³
T75	B (NC)	5Arms, 120VAC, resistive	50x10 ³
T75		7.2 FLA / 45 LRA, 120 VAC	30x10 ³
T75		5 FLA / 30 LRA, 240 VAC	10x10 ³

Contact ratings

Type	Contact	Load	Cycles
T75	A (NO)	TV4, Tungsten, 120VAC, 40°C	25x10 ³
T75	C (CO)	10A, 240VAC, general purpose, 40°C	6x10 ³
T75	C (CO)	8A, 24VDC, general purpose, 40°C	100x10 ³
T75	C (CO)	1/3HP, 120VAC, 40°C	30x10 ³
T75	C (CO)	1/2HP, 240VAC, 40°C	30x10 ³

Mechanical endurance, DC coil 10x10⁶ operations

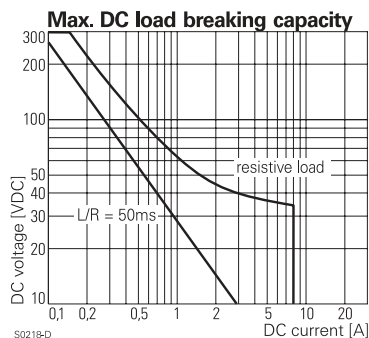

Coil Data

Coil voltage range	3 to 60VDC
Operative range, IEC 61810	2
Coil insulation system according UL	classA

Coil versions, DC coil

Coil code	Rated voltage VDC	Operate voltage VDC	Release voltage VDC	Coil resistance Ω±10% ¹⁾	Rated coil power mW
03	3	2.1	0.3	40	225
05	5	3.4	0.5	118	212
06	6	4.1	0.6	165	218
09	9	6.1	0.9	364	223
12	12	8.2	1.2	652	221
24	24	16.3	2.4	2270	254
48	48	32.6	4.8	8790	262
60	60	40.8	6.0	15265 ¹⁾	236

1) Coil resistance ±15%.

All figures are given for coil without pre-energization, at ambient temperature +23°C. Other coil voltages on request.

Insulation Data

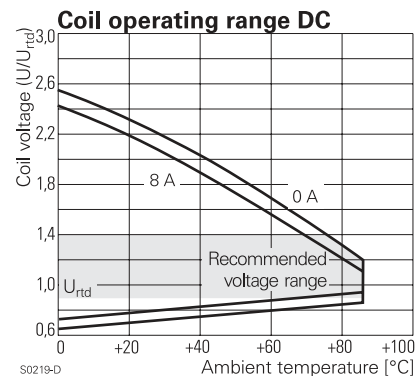

Initial dielectric strength

between open contacts	1000V _{rms}
between contact and coil	4000V _{rms}

Clearance/creepage

between contact and coil	≥8/8mm
--------------------------	--------

Material group of insulation parts

IIIa

Low profile, PCB Relay T75 Series (Continued)

Other Data

Material compliance: EU RoHS/ELV, China RoHS, REACH, Halogen content refer to the Product Compliance Support Center at www.te.com/customersupport/rohssupportcenter

Ambient temperature	- 40 to +85°C
Category of environmental protection	RTII - flux proof RTIII - wash tight
Vibration resistance (functional)	
form A (NO) / form B (NC)	10/4g
Vibration resistance (destructive)	
form A (NO) / form B (NC)	20/5g
Shock resistance (destructive)	100g
Terminal type	PCB-THT
Weight	11g
Resistance to soldering heat THT	
IEC 60068-2-20	RTIII: 260°C/5s
Packaging/unit	tube/20 pcs., box/1000 pcs.

PCB layout / terminal assignment

1 form C, 1 CO contact, 3.2mm

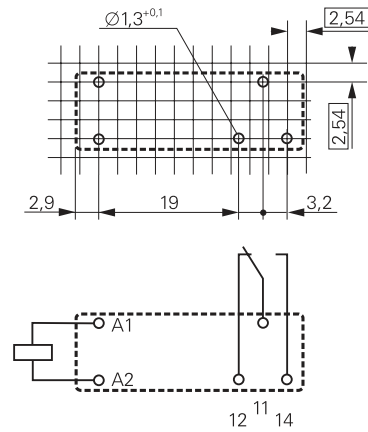

1 form A, 1 NO contact, 5mm

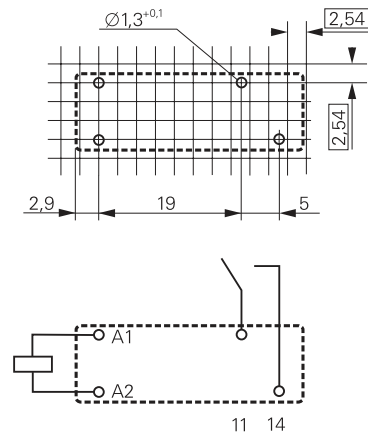

Dimensions

1 form C, 1 CO contact, 3.2mm

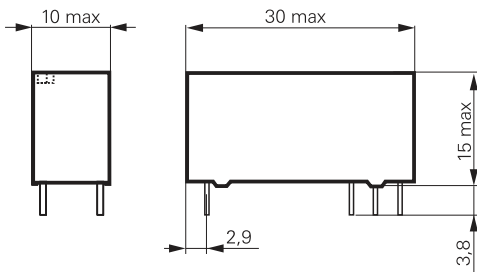

1 form A, 1 NO contact, 5mm

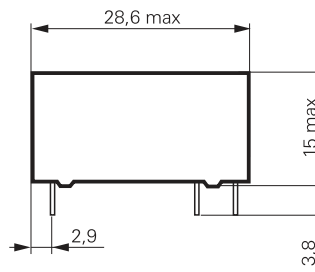

Low profile, PCB Relay T75 Series (Continued)

Product code structure	Typical product code	T75	S	5	D	1	1	2	-12
Type	Low profile, printed circuit board relay T75 Series								
Enclosure	S RTIII - wash tight								
Contact arrangement	1 1 form A, 1 NO		5 1 form C, 1 CO						
Coil input	D DC voltage								
Coil configuration	1 Single coil, monostable (non-latching)								
Mounting and terminals	1 PCB terminals								
Contact materials	2 AgCdO								
Coil voltage	Coil code: please refer to coil versions table (e.g. 05=5VDC)								

Product code	Arrangement	Enclosure	Coil	Part Number
T75S1D112-05	1 form A, 1 NO	RTIII - wash-tight	5VDC	1393222-7
T75S1D112-06			6VDC	5-1393223-2
T75S1D112-12			12VDC	2-1393222-9
T75S1D112-24			24VDC	4-1393222-8
T75S5D112-05	1 form C, 1 CO		5VDC	7-1393222-6
T75S5D112-09			9VDC	9-1393222-0
T75S5D112-12			12VDC	1393223-3
T75S5D112-18			18VDC	1-1393223-6
T75S5D112-24			24VDC	2-1393223-8
T75S5D112-48			48VDC	4-1393223-1
T75S5D112-60			60VDC	1423089-1