

REVISIONS			
REV.	DESCRIPTION	DATE	APPROVED
A	INITIAL RELEASE	05/14/09	M.J.

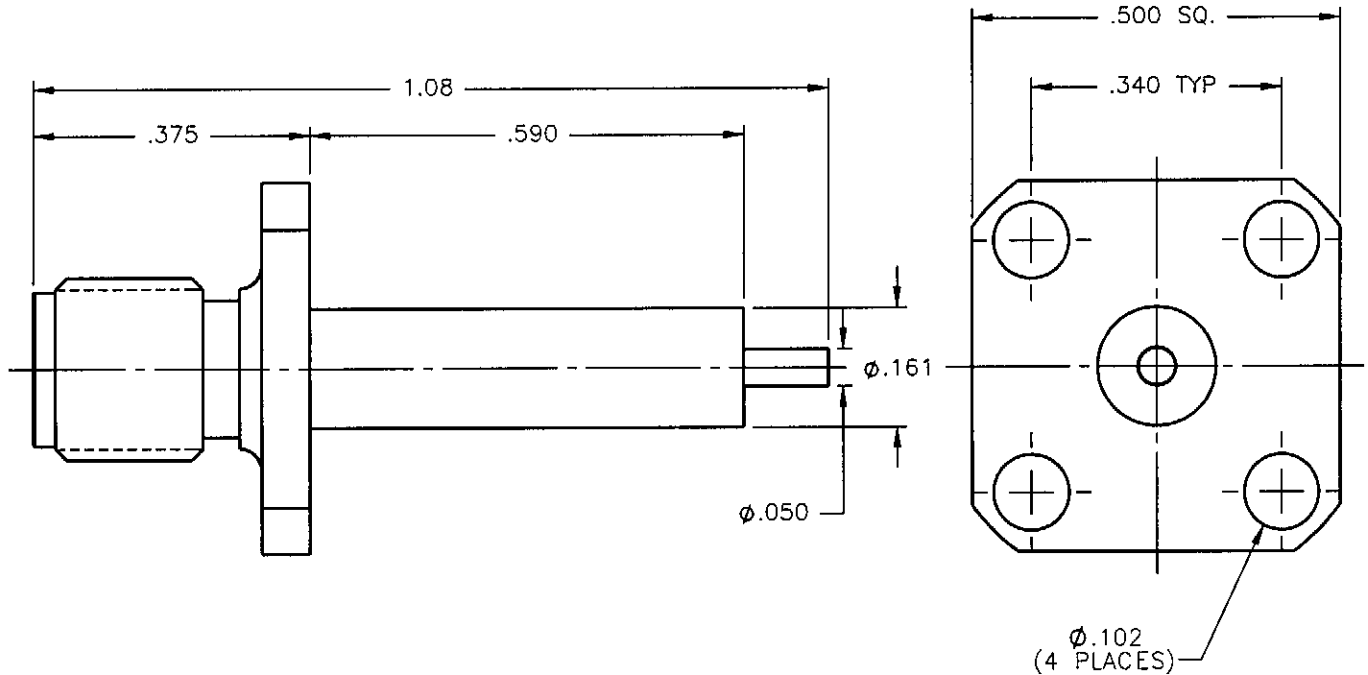

NOTES:



MATERIALS:

1. BODY = STAINLESS STEEL PER ASTM A582, ALLOY 303, CONDITION "A".
2. INSULATOR = VIRGIN WHITE TEFLON PER ASTM D1710, GRADE 1, TYPE I, CLASS "B".
3. CONTACT = BERYLLIUM COPPER PER ASTM B196, ALLOY C17300, TEMPER TD04.

FINISHES:

1. BODY = PASSIVATE PER QQ-P-35, TYPE VI.
2. CONTACT = GOLD PLATE PER MIL-G-45204, TYPE II, CLASS 1, GRADE C, OVER .00010 TO .00020 STRESS FREE SULFAMATE NICKEL PER QQ-N-290.

Property of Radiall Incorporated
 This document cannot be reproduced or
 communicated to a third party without prior
 written permission of RADIALL Incorporated.

UNLESS OTHERWISE SPECIFIED DIMENSIONS ARE IN INCHES TOLERANCES ON	DWN:	DATE	 APPLIED ENGINEERING PRODUCTS 104 John W. Murphy Dr. New Haven, CT 06513
	M.J.	05/14/09	
DECIMAL	ANGLE	CHKD:	SMA STRAIGHT JACK (4) HOLE MOUNT RECEPTACLE
		D.N.	
		APVD:	SIZE A FSCM NO. 19505 DWG NO. 9004-9213-000 REV A
		J.M.	SCALE 4:1 THIRD ANGLE PROJECTION  SHEET 1 OF 1
REFERENCE:	MATERIALS & FINISHES:		
ORIGINATED: M.J. DATE: 05/14/09	SEE NOTES		

9004-9213-000