

THIS COPY IS PROVIDED ON A RESTRICTED BASIS AND IS NOT TO BE USED IN ANY WAY DETRIMENTAL TO THE INTERESTS OF PANDUIT CORP.

PANDUIT PART NUMBER	STUD SIZE	DIMENSIONS - in.					TOOL
		A +/- .03	W +/- .01	C +/- .015	M +/- .03	H +/- .01	
P22-4F	#4	.49 (12.45)	.19 (4.83)	.20 (5.08)	.39 (9.91)	.13 (3.30)	CT-100A (POCKET B)
P22-6F	#6	.59 (14.99)	.25 (6.35)	.26 (6.60)	.47 (11.94)	.15 (3.81)	CT-200

NOTES:

1. RECOMMENDED FOR #26-22 SOLID OR STRANDED COPPER WIRE
2. MATERIAL:
A. STAMPING - .020 (0.51) THK COPPER, TIN PLATED
3. SEE WWW.PANDUIT.COM FOR PACKAGE QUANTITIES
4. DIMENSIONS IN BRACKETS ARE IN MILLIMETERS
5. WIRE STRIP LENGTH: $3/16 + 1/32$ (4.8 + .8)
- 0 - 0

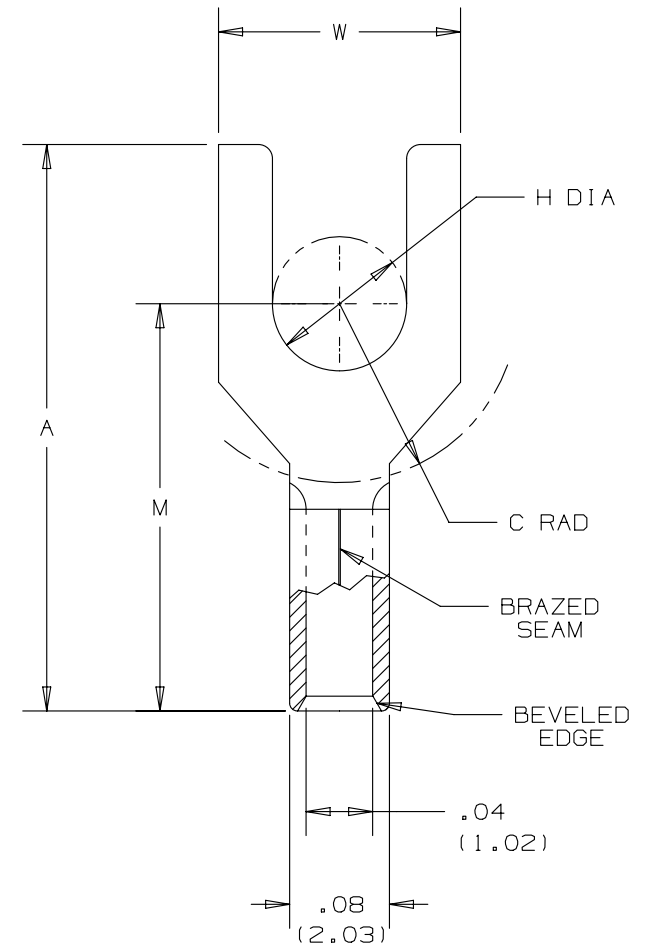

REV	DATE	BY	CHK	APR	DESCRIPTION	ECN
07	4/14	JHNU	JHNU	RGB	REVISED LAYOUT OF TOOL IN TABLE	N41229BA-DC
06	4/14	JHNU	JHNU	RGB	REVISED NOTES, TABLE REVISED TITLE BLOCK	N41229BA-DC

TITLE		#26-22 BARREL NON-INSULATED FORK TONGUE	
		CUSTOMER DRAWING	
ITEM REVISION NAME		N41229BA/07	
DATASET FILE NAME		N41229BA/07	
UNLESS OTHERWISE SPECIFIED, DIMENSIONAL TOLERANCES ARE: IN (mm)		MATERIAL: SEE NOTES	
.X ± .XX ±		.XXX ± ANGLES ±	
		THIRD ANGLE PROJECTION	
DRAWN BY DAW		DATE	SCALE N/A
CHK		DRAWING NUMBER: N41229BA-DC	
ECN		SHT 1 OF 1	
		SIZE A	

D10100DA/16