

PDR#S-001735-00-00 EC NO: S2008-0445 DRWN:SKANG CHKD:ATSEE APPR:MLONG	2007/12/12	2007/12/12	2007/12/13
	REV	DESCRIPTION	QUALITY SYMBOLS
D2		▽=0	∇=0

GENERAL TOLERANCES (UNLESS SPECIFIED)	mm	INCH
	4 PLACES ± ---	± ---
3 PLACES ± ---	± ---	
2 PLACES ± 0.13	± ---	
1 PLACE ± 0.25	± ---	
ANGULAR ± 3 °		
DRAFT WHERE APPLICABLE MUST REMAIN WITHIN DIMENSIONS		

DIMENSION STYLE		SCALE	DESIGN UNITS	THIRD ANGLE PROJECTION
MM/IN		NTS	METRIC	
DRAWN BY	DATE	TITLE		
KMGOH	2002/11/19	POWER CONN. RECEPTACLE		
CHECKED BY	DATE	P(B)-S-P(A) CONFIG.		
PTLIM	2002/11/21	RIGHT ANGLE, THRU HOLE		
APPROVED BY	DATE	MOLEX INCORPORATED		
SKTOH	2002/11/21	MOLEX INCORPORATED		
MATERIAL NO.	DOCUMENT NO.	SHEET NO.		
SEE TABLE	SD-87632-013	1 OF 3		

THIS DRAWING CONTAINS INFORMATION THAT IS PROPRIETARY TO MOLEX INCORPORATED AND SHOULD NOT BE USED WITHOUT WRITTEN PERMISSION	
---	--

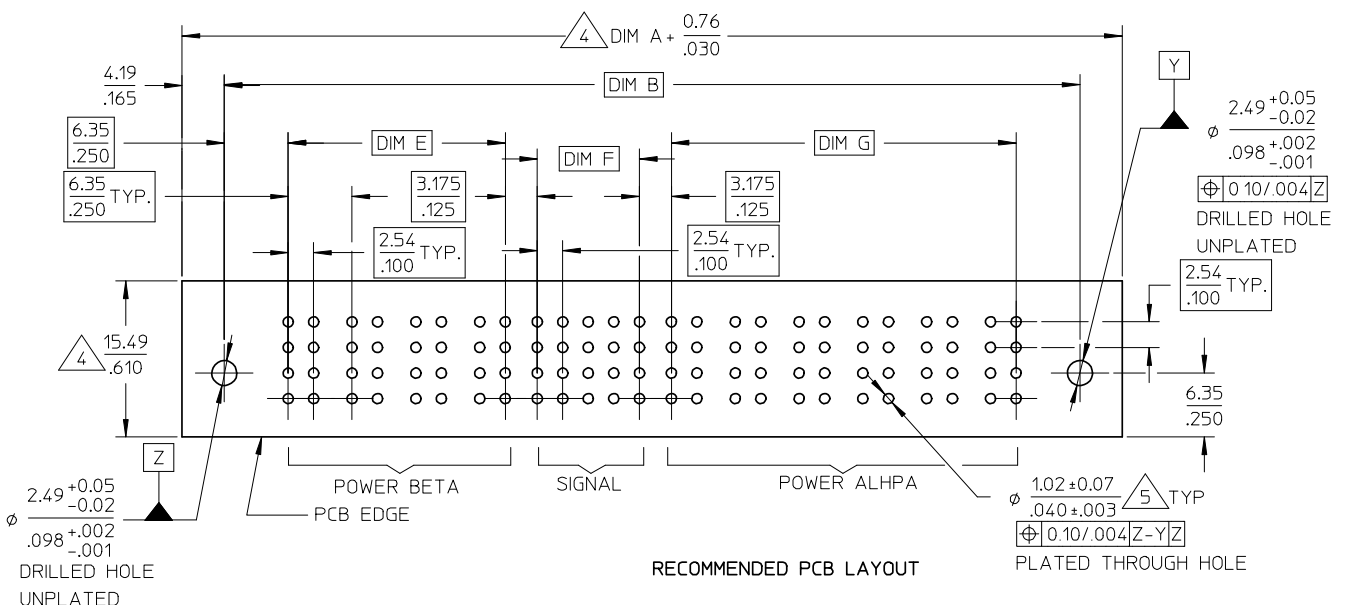

- NOTES
- MATERIALS :-
HOUSING - HIGH TEMPERATURE THERMO-PLASTIC,
GLASS FILLED, UL94V-0, COLOR : BLACK.
SIGNAL TERMINAL - COPPER ALLOY
POWER TERMINAL - COPPER ALLOY
 - FINISH :-
SIGNAL & POWER CONTACTS
0.76um MIN. GOLD (Au) AT CONTACT AREA AND 2.54um MIN. TIN
AT SOLDER TAIL AREA OVER 1.27um MIN. NICKEL (Ni) UNDERPLATE.
BOARD-LOCK - 2.54 MICROMETER MINIMUM TIN (Sn) OVER
1.27 MICROMETER MINIMUM NICKEL (Ni) UNDERPLATE
 - PRODUCT SPECIFICATION : PS-87631-006.
 - COMPONENT STAY AWAY ZONE FROM CONNECTOR.
 - PCB NOTE FOR DIAMETER 1.02/.040 PLATED HOLE
- DRILLED HOLE SIZE IS 1.151/.0453
- PLATE WITH 0.007/.0003 MINIMUM TIN OVER 0.03/.001
TO 0.08/.003 COPPER PLATING TO ACHIEVE 1.02±0.08/.040±.003 HOLE.
 - ALL TERMINAL TIPS ARE DESIGNED WITH EXPOSE BASE COPPER.
THIS IS CREATED BY FINAL CUTTING PROCESS PLATING.
 - MANUFACTURER LOGO, PART NUMBER AND YEAR-WEEK CODE.
 - 4 POWER BETA-20SIGNAL-6 POWER ALPHA IS SHOWN FOR ILLUSTRATION.
POWER-SIGNAL-POWER CONFIGURATION IS AVAILABLE UP TO 203MM/8INCH.
PLEASE CONTACT MOLEX SALES PERSONNEL FOR OTHER CONFIGURATION
AND OPTION NEEDED.



RECOMMENDED PCB LAYOUT

PDR#S-001735-00-00 EC NO: S2008-0445 DRWN:SKANG 2007/12/12 CHKD:ATSEE 2007/12/12 APPR:MLONG 2007/12/13	QUALITY SYMBOLS ▽=0 ▽=0	GENERAL TOLERANCES (UNLESS SPECIFIED)		DIMENSION STYLE MM/IN		SCALE NTS	DESIGN UNITS METRIC	THIRD ANGLE PROJECTION		
			mm	INCH	DRAWN BY	DATE	TITLE			
		4 PLACES	± ---	± ---	KMGOH	2002/11/19	POWER CONN. RECEPTACLE P(B)-S-P(A) CONFIG. RIGHT ANGLE, THRU HOLE			
		3 PLACES	± ---	± ---	CHECKED BY	DATE	MOLEX INCORPORATED			
	± 0.13	± ---	PTLIM	2002/11/21	APPROVED BY		DATE		MATERIAL NO. DOCUMENT NO.	
2 PLACES	± 0.25	± ---	SKTOH	2002/11/21	SEE TABLE		SD-87632-013			
ANGULAR ± 3 °		DRAFT WHERE APPLICABLE MUST REMAIN WITHIN DIMENSIONS		SIZE A3		THIS DRAWING CONTAINS INFORMATION THAT IS PROPRIETARY TO MOLEX INCORPORATED AND SHOULD NOT BE USED WITHOUT WRITTEN PERMISSION				
SHEET NO. 2 OF 3										

10	9			8	7			6			5	4	3	2	1
	ASSEMBLY PART NUMBER	P-S-P CONFIGURATION POWER BETA	SIGNAL		POWER ALPHA	RECESSED POWER CIRCUIT #	DIM A	DIM B	DIM C	DIM D					
F	87632-3000	5	24	3	NIL	82.54 3.250	74.93 2.950	73.65 2.900	59.69 2.350	27.94 1.100	12.70 .500	15.24 .600	TRAY		
	87632-3001	4	20	6	NIL	92.71 3.650	85.10 3.350	83.82 3.300	69.86 2.750	21.59 .850	10.16 .400	34.29 1.350	TRAY		
	87632-3006	2	32	2	NIL	62.23 2.450	54.61 2.150	53.34 2.100	39.37 1.550	8.89 .350	17.78 .700	8.89 .350	TRAY		
	87632-3009	4	24	2	NIL	69.84 2.750	62.23 2.450	60.95 2.400	46.99 1.850	21.59 .850	12.70 .500	8.89 .350	TRAY		
	87632-3011	1	16	1	NIL	39.37 1.550	31.75 1.250	30.48 1.200	16.51 .650	2.54 .100	7.62 .300	2.54 .100	TRAY		
E	87632-3013	5	32	5	NIL	100.33 3.950	92.71 3.650	91.44 3.600	77.47 3.050	27.94 1.100	17.78 .700	27.94 1.100	TRAY		
	87632-3017	4	28	4	NIL	85.09 3.350	77.47 3.050	76.20 3.000	62.23 2.450	21.59 .850	15.24 .600	21.59 .850	TRAY		
	87632-3018	4	40	4	NIL	92.71 3.650	85.09 3.350	83.82 3.300	69.85 2.750	21.59 .850	22.86 .900	21.59 .850	TRAY		
	87632-3019	2	16	2	NIL	52.08 2.050	44.46 1.750	43.19 1.700	29.22 1.150	8.89 .350	7.62 .300	8.89 .350	TRAY		
	87632-3020	2	12	2	NIL	49.53 1.950	41.91 1.650	40.64 1.600	26.67 1.050	8.89 .350	5.08 .200	8.89 .350	TRAY		
D	87632-3021	4	24	4	NIL	82.55 3.250	74.93 2.950	73.66 2.900	59.69 2.350	21.59 .850	12.70 .500	21.59 .850	TRAY		

C

B

PDR# S-001735-00-00 EC NO: S2008-0445 DRWN: SKANG CHKD: ATSEE APPR: MLONG 2007/12/12 2007/12/12 2007/12/13	QUALITY SYMBOLS  = 0  = 0.13	GENERAL TOLERANCES (UNLESS SPECIFIED)		DIMENSION STYLE MM/IN		SCALE NTS	DESIGN UNITS METRIC	 THIRD ANGLE PROJECTION	
		4 PLACES ± --- ± --- 3 PLACES ± --- ± --- 2 PLACES ± 0.13 ± --- 1 PLACE ± 0.25 ± ---	mm INCH ± --- ± --- ± 0.13 ± --- ± 0.25 ± ---	DRAWN BY KMG0H	DATE 2002/11/19	TITLE POWER CONN. RECEPTACLE P(B)-S-P(A) CONFIG. RIGHT ANGLE, THRU HOLE			
		ANGULAR ± 3 °		CHECKED BY PTL IM	DATE 2002/11/21	MOLEX INCORPORATED			
		DRAFT WHERE APPLICABLE MUST REMAIN WITHIN DIMENSIONS		APPROVED BY SKTOH	DATE 2002/11/21	MATERIAL NO. SEE TABLE	DOCUMENT NO. SD-87632-013	SHEET NO. 3 OF 3	