

PART NUMBER	REV	FIRST USED
680372-1	C	122500-1
680372-2	B	565435-5
680372-3	C	354500-1

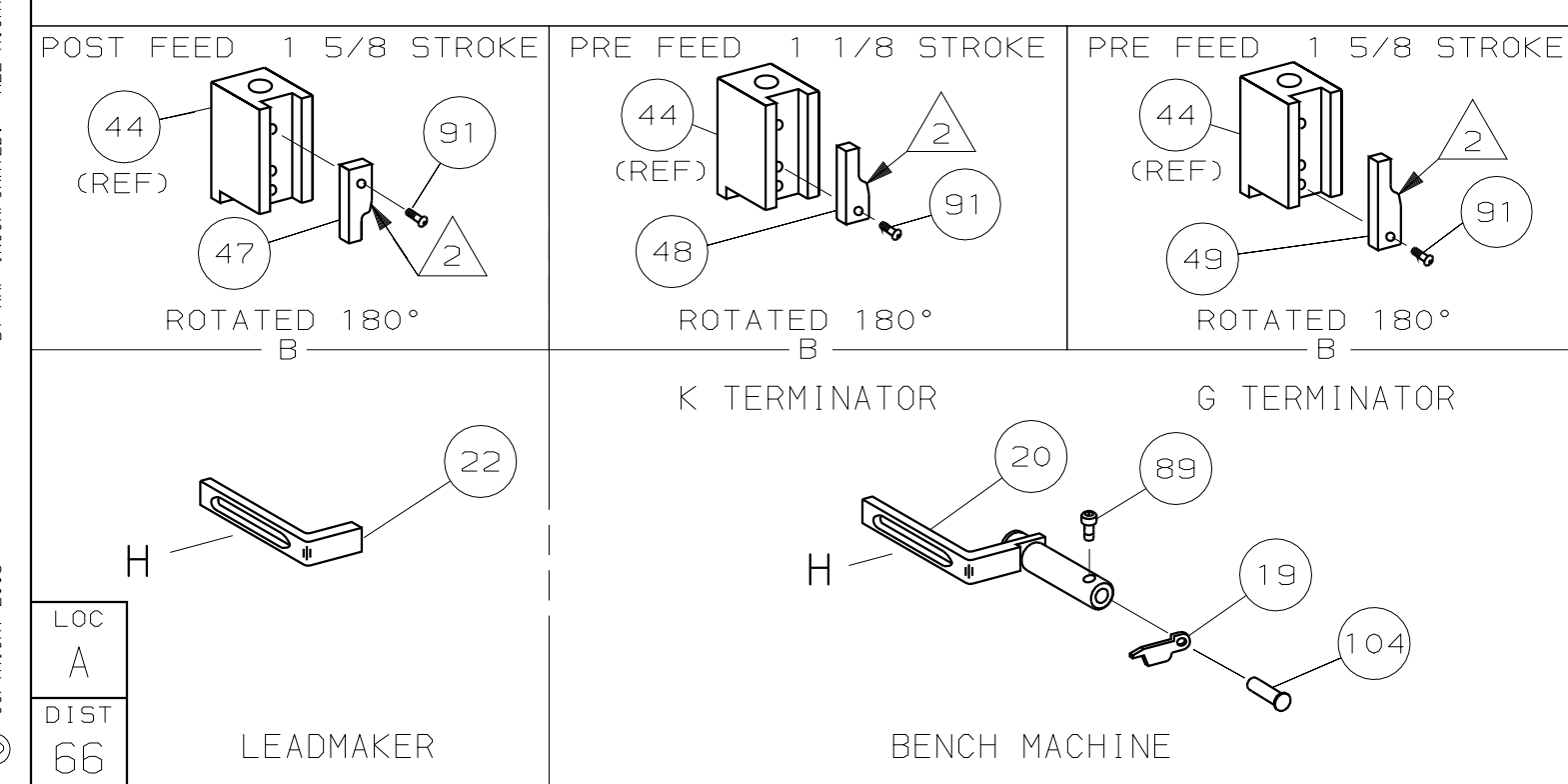
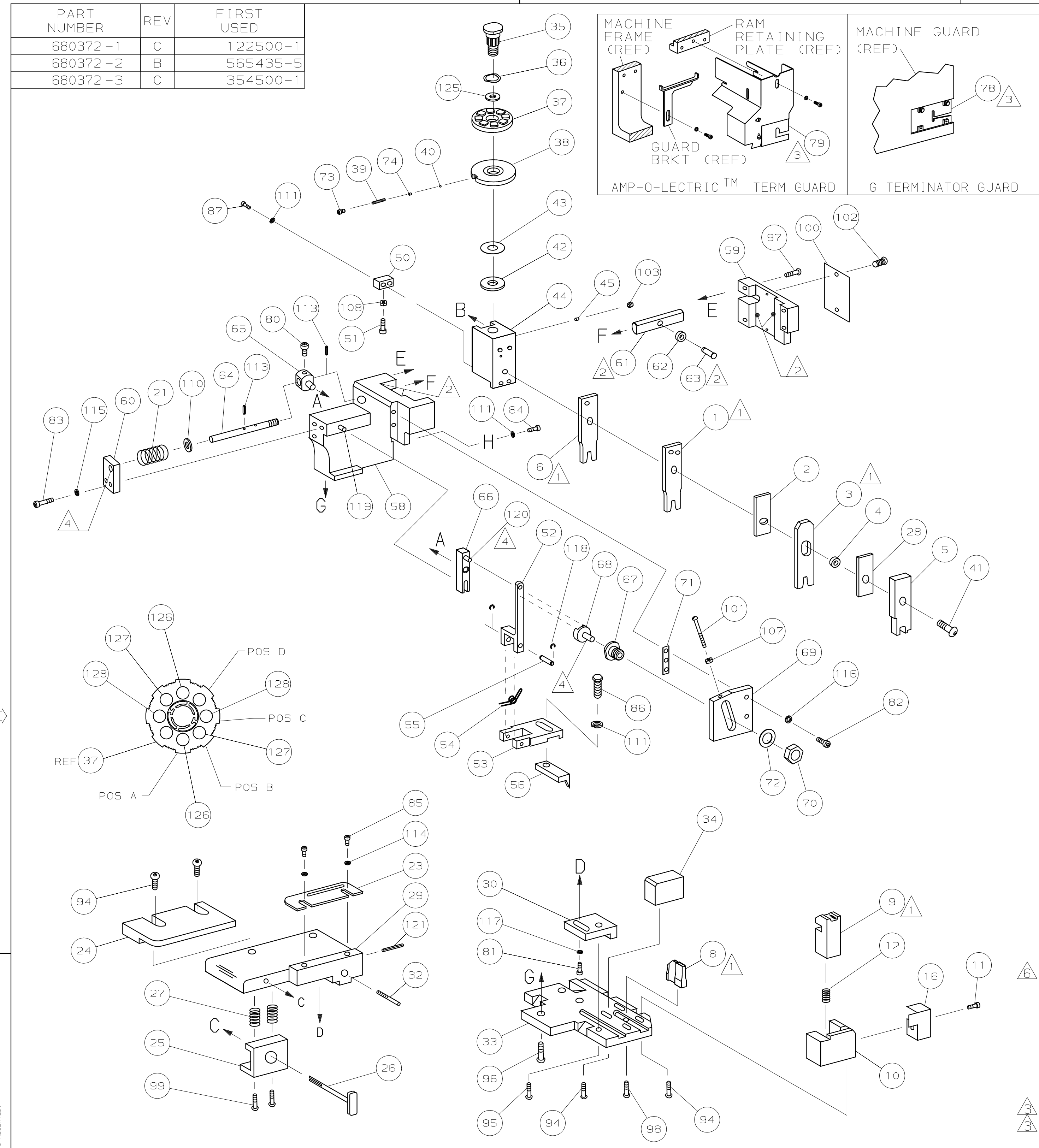

- 1 RECOMMENDED SPARE PARTS.
- 2 GREASE LIGHTLY.
- 3 GUARD MUST BE IN PLACE WHEN OPERATING APPLICATOR IN A BENCH MACHINE.
- 4 LUBRICATE DAILY USING NO. 20 MACHINE OIL.
- 5. ITEMS WITH QTY OF REF SPECIFIED (EXCEPT ITEMS 78 AND 79) ARE USED ON ITEM 46.
- 6 CUT TO LENGTH AT ASSY

TERMINAL NAME: QUICK CRIMP CONTACT			
927985			
PAD LTR	CRIMP HEIGHT	WIRE SIZE	
A	.028 ±.002 [0.72 ±0.05mm]	24	
B	.026 ±.002 [0.66 ±0.05mm]	26	
C	.025 ±.002 [0.63 ±0.05mm]	28	
D	NOT	USED	
CRIMP	SIZE	TYPE	RANGE
WIRE	.042 [1.07mm]	F	28-24
INSUL	.055 [1.40mm]	0	∅.043 MAX

QTY	REF	REF	REF	REF	REF	DESCRIPTION	ITEM NO
2	2	2	-	C	6-354779-7	PIN, WIRE DISC (.3325)C	129
2	2	2	-	C	6-354779-5	PIN, WIRE DISC (.3315)B	127
2	2	2	-	C	6-354779-2	PIN, WIRE DISC (.3300)A	126
1	1	1	-	A	986950-1	WASHER, FLAT PRECISION	125
1	1	1	-	A	217238-1	GENERAL INSTRUCTION PACKAGE	124
1	1	1	-	-	4088040	SF APPL INST 408-8040	123
1	1	1	-	-			122
1	1	1	-	A	4-21028-0	PIN,SLT SPR(∅.093x.75)ST GDE PL	121
REF	REF	REF	-	A	1-21030-1	PIN,DOWEL(∅.187x.50)LEVER	120
REF	REF	REF	-	A	1-21030-6	PIN,DOWEL(∅.187x1.25)HOUSING	119
REF	REF	REF	-	A	21045-3	RING,RET "C"(∅.187)FD FING PIN	118
1	1	1	-	A	21024-5	WASHER, LOCK (#10)ADJ BLOCK	117
REF	REF	REF	-	A	21024-5	WASHER,LOCK(#10)ADJ PLATE	116
REF	REF	REF	-	A	21024-5	WASHER,LOCK(#10)FEED GDE ROD	115
2	2	2	-	A	21024-2	WASHER,LOCK(#4)FRONT STP GUIDE	114
REF	REF	REF	-	A	5-21028-1	PIN,SLT SPR(∅.125x.50)ADJ ROD	113
4	4	4	-	A	21024-4	WASHER,LOCK(#8)STRIPPER	112
REF	REF	REF	-	A	21899-4	WASHER,FLAT(∅5/16)SCREW ADJ	110
1	1	1	-	A	21018-5	NUT, HEX(NO.6)HOLDDOWN	108
REF	REF	REF	-	A	21018-5	NUT, HEX(6-32)FEED ADJ	107
1	1	1	-	-			106
1	1	1	-	-			105
1	1	1	-	A	992031-1	PIN, CLEVIS	104
1	1	1	-	A	21009-2	SCR,SKT SET(1/4-20x.25 LW)RAM	103
2	2	2	-	A	21017-2	SCR,DRIVE(#2x.19)ID PLATE	102
REF	REF	REF	-	A	6-23715-5	SCR,PAN HD(6-32x1.50)FEED ADJ	101
1	1	1	-	B	461264-1	PLATE, IDENTIFICATION	100
2	2	2	-	A	3-21002-0	SCR,BHC(10-32x.88)DRAG	99
1	1	1	-	A	22733-8	SCR,BHC(8-32x.38 LW)ANVIL	98
REF	REF	REF	-	A	2-21002-9	SCR,BHC(10-32x.75)CAP	97
REF	REF	REF	-	A	2-22733-8	SCR,BHC(1/4-20x.62)HOUSING	96
REF	REF	REF	-	A	2-21002-7	SCR,BHC(10-32x.50)SG ADJ BLOCK	95
6	6	6	-	A	2-21002-2	SCR,BHC(8-32x.50)TERM H DWN	94
1	1	1	-	-			93
1	1	1	-	-			92
1	1	1	-	A	1-21002-7	SCR,BHC(6-32x.38)CAM	91
1	1	1	-	-			90
1	1	1	-	A	7-21000-9	SCR,SHC(4-40x.19)STRIPPER	89
2	2	2	-	A	2-21000-7	SCR,SHC(8-32x.48)DEP-HOLD	87
1	1	1	-	A	2-22603-0	SCR,HEX HD(8-32x.31)FEED FINGER	86
2	2	2	-	A	1-21000-3	SCR,SHC(4-40x.25)F ST GUIDE	85
1	1	1	-	A	2-21000-7	SCR,SHC(8-32x.50)STRIPPER	84
REF	REF	REF	-	A	3-21000-7	SCR,SHC(10-32x.75)FEED ROD GD	83
REF	REF	REF	-	A	3-21000-6	SCR,SHC(10-32x.62)FD ADJ BLK	82
1	1	1	-	A	3-21000-4	SCR,SHC(10-32x.38)SG ADJ BL	81
REF	REF	REF	-	A	3-21000-4	SCR,SHC(10-32x.38)PIVOT BLK	80
-	REF	-	-	B	455749-1	GUARD, WINDOW	79
REF	-	-	-	B	679532-1	INSERT, GUARD	78
1	1	1	-	-			77
1	1	1	-	-			76
1	1	1	-	A	690603-1	SPRING, ASSIST	74
1	1	1	-	A	23030-1	SCR,SHC(6-32x.25 SL)INS DISC	73
REF	REF	REF	-	A	458109-1	WASHER, SPECIAL	72
REF	REF	REF	-	A	690517-1	SPACER	71
-3	-2	-1	U/M	DWG SIZE	PART NO	DESCRIPTION	ITEM NO

QTY	REF	REF	REF	REF	REF	DESCRIPTION	ITEM NO
1	1	1	-	B	690542-2	PAWL, FEED	56
REF	REF	REF	-	B	240624-1	PIN, FEED FINGER	55
REF	REF	REF	-	B	691499-1	SPRING, FEED FINGER	54
REF	REF	REF	-	B	690541-1	HOLDER, FEED FINGER	53
REF	REF	REF	-	A	455679-1	LEVER, TERMINAL FEED ARM	52
1	1	1	-	A	811242-2	BUMPER, HOLDDOWN	51
1	1	1	-	A	690753-1	SPACER, TONKER	50
1	-	-	-	B	690602-6	CAM, PRE-FEED 1 5/8 ST	49
-	1	-	-	B	690602-5	CAM, PRE-FEED 1 1/8 ST	48
-	-	-	-	B	690501-4	CAM, POST-FEED 1 5/8 ST	47
1	1	1	-	B	459456-1	APPLICATOR, BASIC (SUBASSY)	46
1	1	1	-	A	690191-1	PLUG, NYLON	45
1	1	1	-	C	455673-1	RAM	44
1	1	1	-	A	690125-1	WASHER, LAMINATED	43
1	1	1	-	A	690124-1	WASHER, RAM	42
1	1	1	-	A	7-21002-9	BOLT, CRIMPER(5/16x1.00)	41
1	1	1	-	A	23241-6	BALL, STEEL	40
1	1	1	-	A	690170-1	SPRING, COMPRESSION	39
1	1	1	-	C	690142-1	DISC, INSULATION	38
1	1	1	-	D	354777-1	WIRE DISC, PLASTIC	37
1	1	1	-	A	22480-5	WASHER, SPRING	36
1	1	1	-	B	690212-1	POST, RAM	35
1	1	1	-	B	690786-1	SUPPORT, TERMINAL	34
REF	REF	REF	-	D	455675-1	PLATE, BASE	33
1	1	1	-	A	690432-3	SCREW, ADJUSTMENT	32
REF	REF	REF	-	B	455689-1	BLOCK, STRIP GUIDE ADJ	30
1	1	1	-	C	3-455671-5	PLATE, STRIP GUIDE	29
1	1	1	-	C	2-455888-8	SPACER, FRONT SHEAR DEP	28
2	2	2	-	A	1-22284-0	SPRING, DRAG	27
1	1	1	-	B	690546-1	LEVER, DRAG RELEASE	26
1	1	1	-	B	240792-1	DRAG, TERMINAL	25
1	1	1	-	D	6-690504-3	GUIDE, STRIP (REAR)	24
1	1	1	-	A	690438-1	GUIDE, STRIP (FRONT)	23
-	-	1	-	B	690472-2	STRIPPER	22
REF	REF	REF	-	A	4-22284-9	SPRING, FEED RETURN	21
1	1	1	-	A	679218-1	STRIPPER WIRE STOP ASSY	20
1	1	1	-	B	458949-2	STRIPPER	19
1	1	1	-	-			18
1	1	1	-	-			17
1	1	1	-	B	318563-1	GUARD, CHIP, FRONT	16
1	1	1	-	-			15
1	1	1	-	-			14
1	1	1	-	-			13
1	1	1	-	A	5-22280-0	SPRING, SHEAR	12
1	1	1	-	B	690461-1	STOP, SHEAR	11
1	1	1	-	C	690459-1	HOLDER, SHEAR (FRONT)	10
1	1	1	-	C	454276-2	SHEAR, FLOAT (FRONT)	9
1	1	1	-	C	464675-3	ANVIL	8
1	1	1	-	-			7
1	1	1	-	C	4-456402-3	CRIMPER, STABILIZER	6
1	1	1	-	C	1-455889-4	DEPRESSOR, SHEAR (FRONT)	5
1	1	1	-	B	238011-6	SPACER, BLOCK CRIMPER	4
1	1	1	-	C	3-683454-4	CRIMPER, INSULATION	3
1	1	1	-	C	455888-2	SPACER, CRIMPER	2
1	1	1	-	C	2-456401-5	CRIMPER, WIRE	1
-3	-2	-1	U/M	DWG SIZE	PART NO	DESCRIPTION	ITEM NO

THIS DRAWING IS A CONTROLLED DOCUMENT.

20NOV06
RELEASED FOR PUBLICATION
BY AMP INCORPORATED. ALL RIGHTS RESERVED.
THIS DRAWING IS UNCLASSIFIED
DATE 06/11/2006 BY 680372-1