

4

3

2

1

THIS DRAWING IS UNPUBLISHED. RELEASED FOR PUBLICATION .19  
 BY AMP INCORPORATED. ALL RIGHTS RESERVED.

LOC		DIST		REVISIONS			
P	LTR	DESCRIPTION		DATE	DWN	APVD	
AF	50	B		REV & REL PER 063A-0143-99	9/9/99	JR	DD

1 CONTINUOUS STRIP ON REEL.

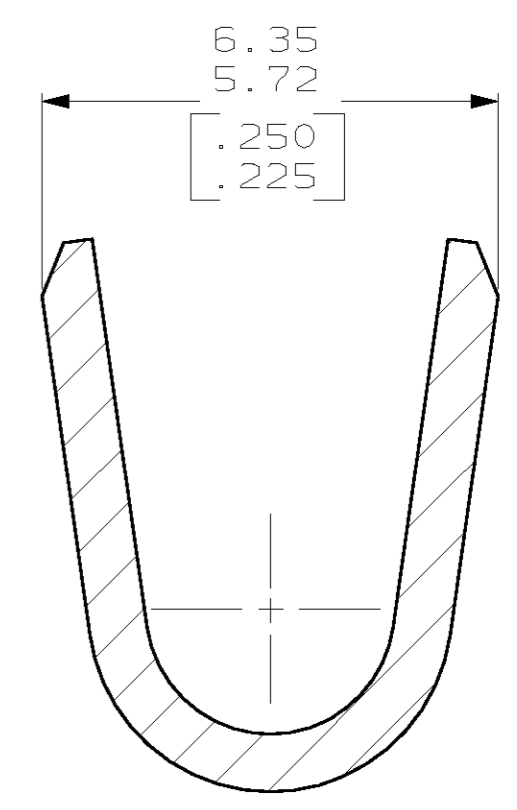
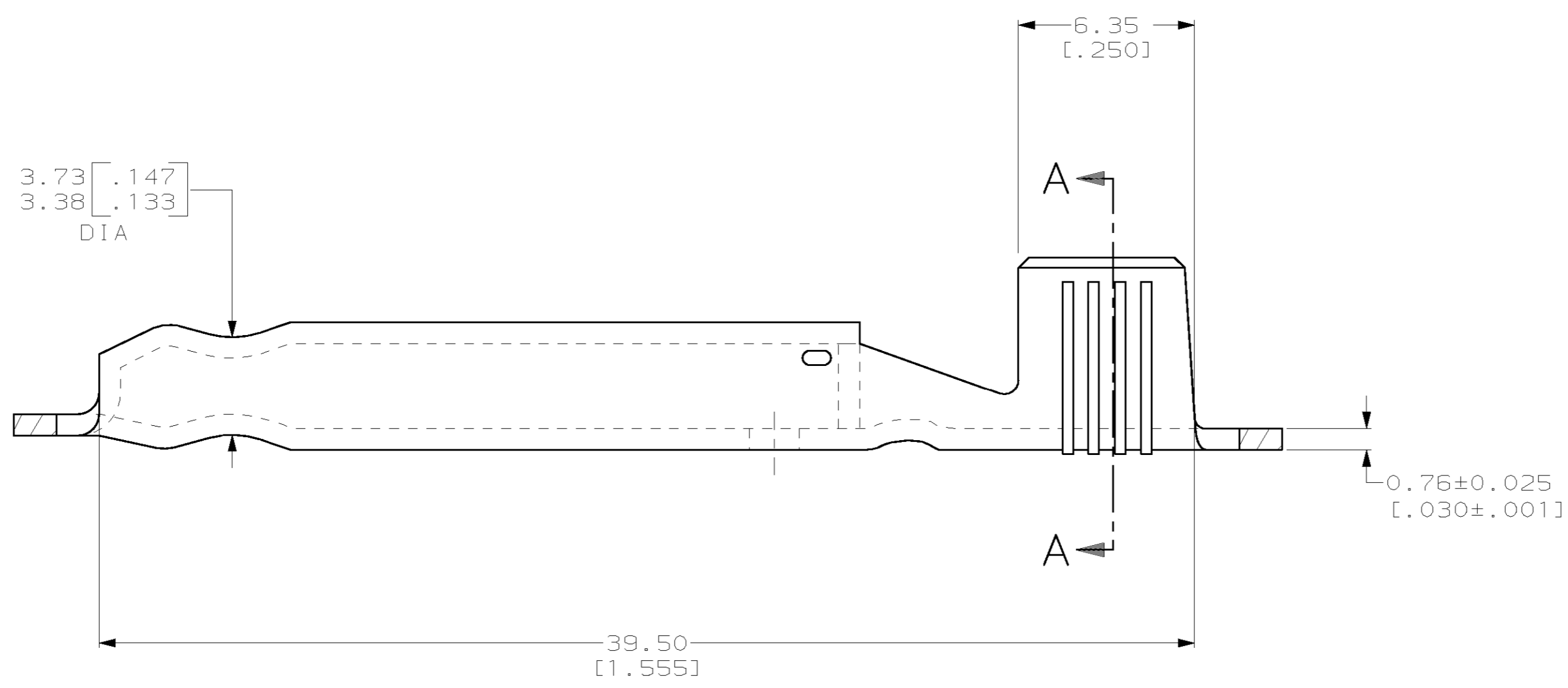
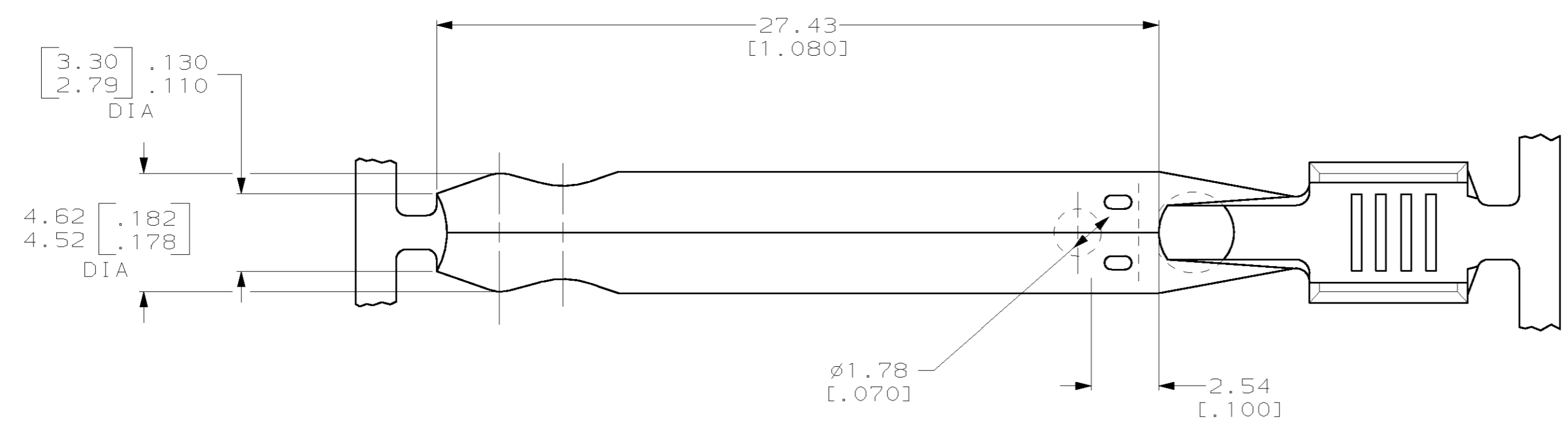

SECTION A-A  
SCALE 10:1

12-8 AWG	1217142-1
WIRE RANGE	PART NUMBER

THIS DRAWING IS A CONTROLLED DOCUMENT.		DWN MICHAEL S. FEHER 04MAY1999	AMP Incorporated Harrisburg, PA 17105-3608	
DIMENSIONS: mm [INCHES]		CHK JEFF R. RUTH 05MAY1999	NAME SHUR PLUG, 4.57 [0.180] DIA	
TOLERANCES UNLESS OTHERWISE SPECIFIED: 0 PLC ±- 1 PLC ±- 2 PLC ±0.25 [.010] 3 PLC ±- 4 PLC ±- ANGLES ±-		APVD DONALD DECKER 05MAY1999	RESTRICTED TO	
MATERIAL 081 BRASS	FINISH 0.002032 [.000080] MIN TIN PLATE	PRODUCT SPEC -	SIZE A2	CAGE CODE 00779
CUSTOMER DRAWING		WEIGHT -	DRAWING NO 1217142	SCALE 6:1
		SHEET 1 OF 1		REV B

1217142