

MATERIALS AND FINISHES

BODY, OC, SLEEVE: BRASS
PLATED: GOLD

CENTER CONTACT: BeCu
PLATED: GOLD

INSULATOR: TEFLON

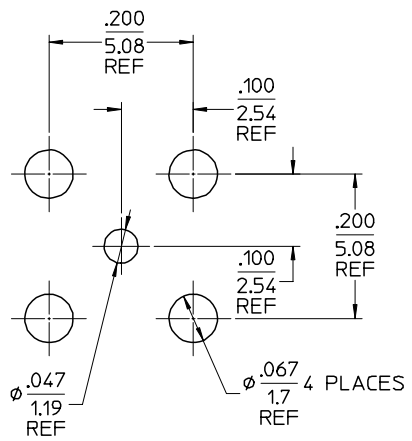
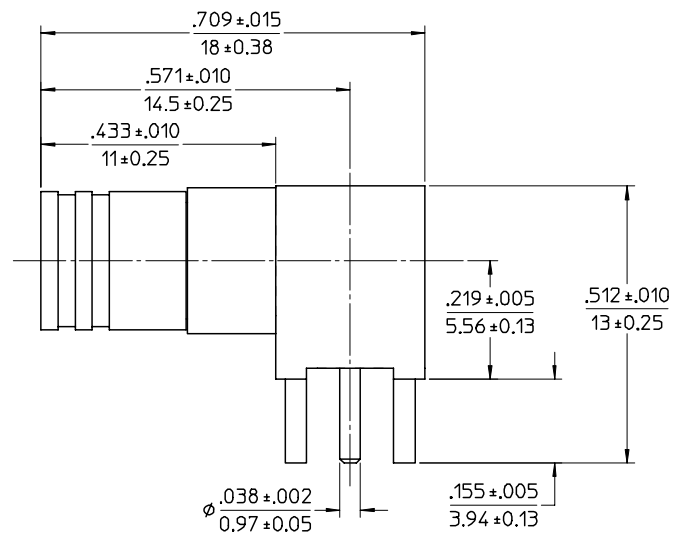
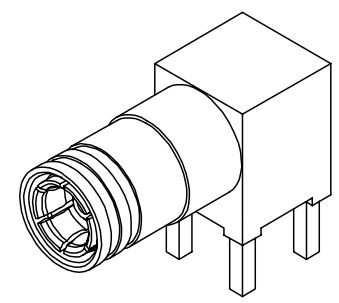

RECOMMENDED BOARD LAYOUT

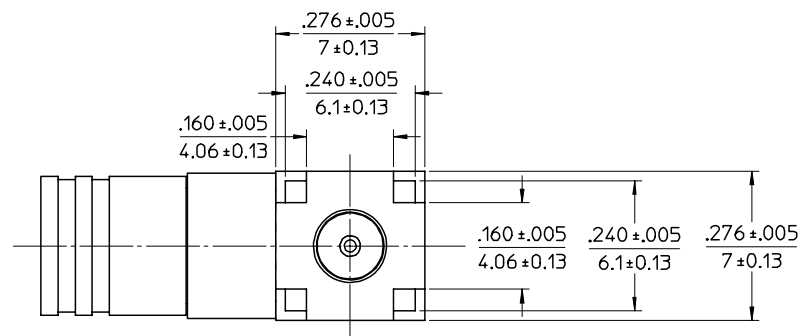

- UNLESS OTHERWISE SPECIFIED DIMS ARE INCHES AND ANGLES ARE DEGREES.
- SURFACE FINISH OF 63 ALL OVER.
 - NO CHATTER OR NON-UNIFORM
 - SURFACE FINISH ALLOWED.
 - PARTS TO BE FREE OF BURRS & SHARP EDGES .005 MAX BREAK.
 - EXTERNAL THREADS TO BE ROLLED OR SINGLE POINT.
 - DIAMETERS TO BE CONCENTRIC WITHIN .003 TIR.

PART # 73404-1390

MIL-STD-348A, FIG. 311-2	INTERFACE
SPECIFICATION	DESCRIPTION

CHG: NEW RELEASE	EC NO. URF-1802 DRWN: SSS 07/16/03 CHK: TEF 07/16/03 APPR: GMH 07/16/03 CHG: XXX	EC NO. URF-XXXX DRWN: XXX 00/00/00 CHK: XXX 00/00/00 APPR: XXX 00/00/00	03/07/16
			DESCRIPTION
A	A	A	REV

QUALITY SYMBOLS	DESCRIPTION
▽ - 0	
∇ - 0	

GENERAL TOLERANCES (UNLESS SPECIFIED)	
	mm INCH
4 PLACES	± .005 ± .0005
3 PLACES	± .005 ± .0005
2 PLACES	± .005 ± .0005
1 PLACE	± .005 ± .0005
ANGULAR ± 1/2°	
DRAFT WHERE APPLICABLE	
MUST REMAIN WITHIN DIMENSIONS	

SCALE 6:1	DESIGN UNITS INCH
DIMENSION STYLE IN/MM	
DRAWN BY TEF	DATE
CHECKED BY TEF	DATE 2003/07/16
APPROVED BY GMH	DATE 2003/06/18

THIRD ANGLE PROJECTION	REVISE ON CAD ONLY
TITLE SMB PLUG RA PCB 50 OHM SMB-P/PCB	
MOLEX INCORPORATED	
MATERIAL NO.	DOCUMENT NO. SD-73404-139
SHEET NO. 1 OF 1	