

**VRM 8.5 COMPATIBLE 5-BIT PROGRAMMABLE SYNCHRONOUS
 BUCK CONTROLLER IC WITH TRIPLE LDO CONTROLLER**

FEATURES

- Meets Latest VRM 8.5 Specification
- Provides Single Chip Solution for Vcore, 1.2V AGTL+, 1.8V and V_{DDQ}
- On-Board 5-Bit DAC and Decoder programs the output voltage from 1.050V to 1.825V
- Loss-less Short Circuit Protection
- Synchronous operation allows maximum efficiency
- Patented architecture allows fixed frequency operation as well as 100% duty cycle when operating with a changing load
- Minimum Part Count, No External Compensation
- Soft-Start
- High current totem pole driver for directly driving an external Power MOSFET
- Power Good Function

APPLICATIONS

- Pentium III with VRM 8.5 Specification
- DC to DC Converters

DESCRIPTION

The IRU3013 controller IC is specifically designed for Intel Pentium III™ microprocessor applications as described in the VRM 8.5 specification. **The IC provides a single chip solution for the Vcore, 1.2V AGTL+, 1.8V and a third uncommitted LDO controller that can be used either as 1.2V power good detector or to provide 1.5V AGP bus in applications that this voltage is required.** The IRU3013 features a patented topology that, in combination with a few external components, (*Note: See application current in Figure 3) will provide in excess of 30A of output current for an on-board Vcore synchronous converter while automatically providing the output voltage specified in VRM 8.5 specification. The IRU3013 also features, **loss-less current sensing by using the R_{DS(ON)} of the high side Power MOSFET as the sensing resistor**, a Power Good window comparator that switches its open collector output low when the output is outside of a ±10% window. Other features of the device are: Under-voltage lockout for both 5V and 12V supplies, an external programmable soft-start function, and the ability to program the oscillator frequency by connecting an external capacitor.

TYPICAL APPLICATION

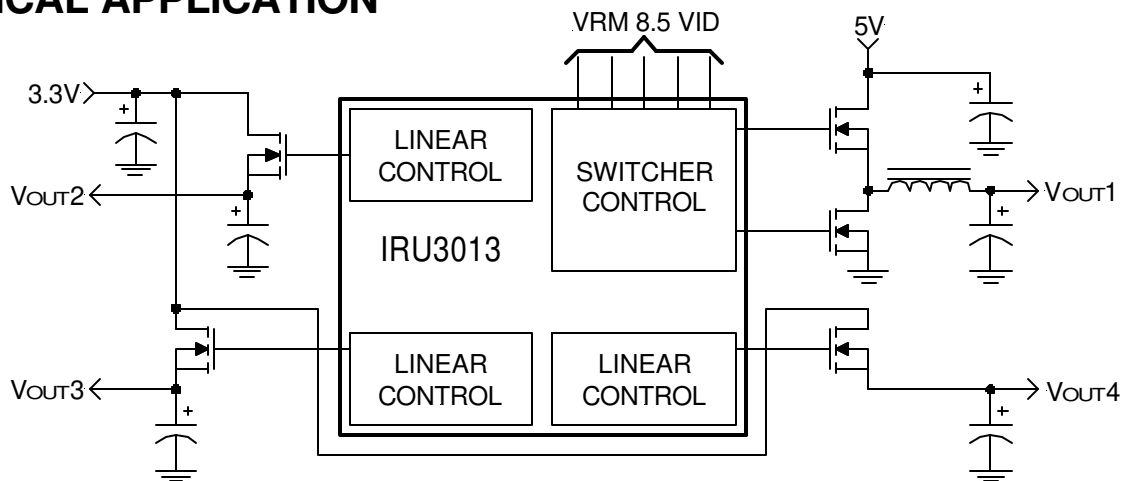

Figure 1 - Typical application of IRU3013.

Note: Pentium III is trade mark of Intel Corp.

PACKAGE ORDER INFORMATION

T _A (°C)	DEVICE	PACKAGE
0 To 70	IRU3013CQ	24-Pin Plastic QSOP NB (Q)
0 To 70	IRU3013CW	24-Pin Plastic SOIC WB (W)

ABSOLUTE MAXIMUM RATINGS

V5 Supply Voltage	10V
V12 Supply Voltage	20V
All Other Pins	7V
Storage Temperature Range	-65°C To 150°C
Operating Junction Temperature Range	0°C To 125°C

PACKAGE INFORMATION

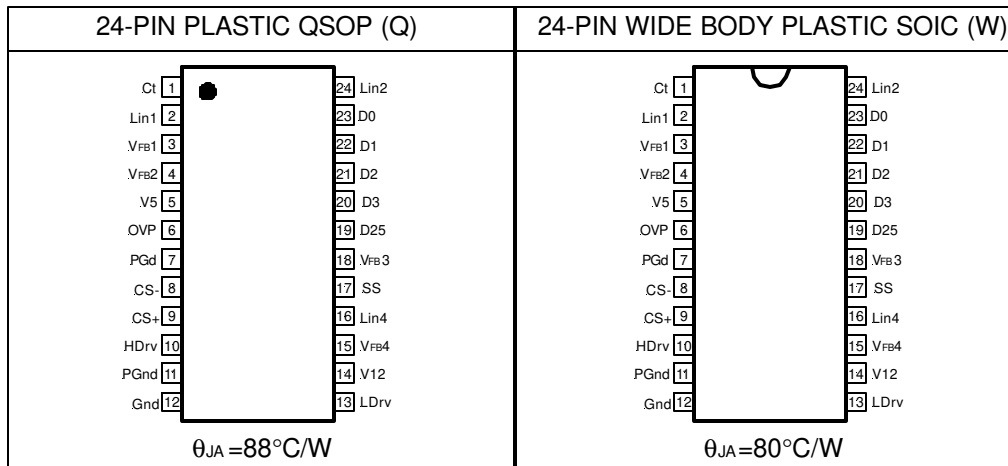

ELECTRICAL SPECIFICATIONS

Unless otherwise specified, these specifications apply over V12=12V, V5=5V and T_A=0 to 70°C. Typical values refer to T_A=25°C. Low duty cycle pulse testing is used which keeps junction and case temperatures equal to the ambient temperature.

PARAMETER	SYM	TEST CONDITION	MIN	TYP	MAX	UNITS
VID Section						
DAC Output Voltage (Note 1)			0.98Vs	Vs	1.02Vs	V
DAC Output Line Regulation		4.5<V _{CC} <5.5 10.5<V12<13V		0.2		%
DAC Output Temp Variation				0.5		%
VID Input LO					0.4	V
VID Input HI			2			V
VID Input Internal Pull-up Resistor to 5V				27		KΩ
Power Good Section						
Under-Voltage Lower Trip Point		V _{OUT} Ramping Down		0.90Vs		V
Under-Voltage Upper Trip Point		V _{OUT} Ramping Up		0.92Vs		V
UV Hysteresis				0.02Vs		V
Over-Voltage Upper Trip Point		V _{OUT} Ramping Up		1.10Vs		V
Over-Voltage Lower Trip Point		V _{OUT} Ramping Down		1.08Vs		V
OV Hysteresis				0.02Vs		V
Power Good Output LO		R _L = 3mA		0.3		V
Power Good Output HI		R _L = 5K Pull-Up to 5V		4.95		V
Soft-Start Section						
Soft-Start Current		CS+ = 0V, CS- = 5V		10		μA

PARAMETER	SYM	TEST CONDITION	MIN	TYP	MAX	UNITS
UVLO Section						
UVLO Threshold - 12V		Supply Ramping Up		9		V
UVLO Hysteresis - 12V				0.5		V
UVLO Threshold - 5V		Supply Ramping Up		4		V
UVLO Hysteresis - 5V				0.3		V
Error Comparator Section						
Input Offset Voltage			-2		+2	mV
Delay to Output		V _{DIFF} = 10mV			100	ns
Current Limit Section						
CS Threshold Set Current			120	150	200	μA
CS Comp Offset Voltage			-5		+5	mV
Hiccup Duty Cycle		C _{SS} = 0.1μF			2	%
Supply Current Section						
Operating Supply Current		C _L = 3000pF V5 V12		20 14		mA
Output Drivers Section						
Rise Time		C _L = 3000pF		70	100	ns
Fall Time		C _L = 3000pF		70	130	ns
Dead Band Time		C _L = 3000pF		200		ns
Oscillator Section						
Osc Frequency		C _t = 150pF		220		KHz
Osc Valley					0.2	V
Osc Peak				V5		V
LDO Controller Section						
V _{FB1} and V _{FB2} (Pins 3 and 4) V _{FB4} (Pin 15)				1.200 0.800		V
Input Bias Current					2	μA
Lin 1, 2, 3 Drive Current				30		mA
OVP Section						
OVP Threshold				1.17Vs		V
OVP Source Current				5		mA

Note: Vs refers to the set point voltage given in table 1.

D25	D3	D2	D1	D0	Vs
0	1	1	1	1	1.300
0	1	1	1	0	1.350
0	1	1	0	1	1.400
0	1	1	0	0	1.450
0	1	0	1	1	1.500
0	1	0	1	0	1.550
0	1	0	0	1	1.600
0	1	0	0	0	1.650
0	0	1	1	1	1.700
0	0	1	1	0	1.750
0	0	1	0	1	1.800
0	0	1	0	0	1.050
0	0	0	1	1	1.100
0	0	0	1	0	1.150
0	0	0	0	1	2.200
0	0	0	0	0	2.250

D25	D3	D2	D1	D0	Vs
1	1	1	1	1	1.325
1	1	1	1	0	1.375
1	1	1	0	1	1.425
1	1	1	0	0	1.475
1	1	0	1	1	1.525
1	1	0	1	0	1.575
1	1	0	0	1	1.625
1	1	0	0	0	1.675
1	0	1	1	1	1.725
1	0	1	1	0	1.775
1	0	1	0	1	1.825
1	0	1	0	0	1.075
1	0	0	1	1	1.125
1	0	0	1	0	1.175
1	0	0	0	1	1.225
1	0	0	0	0	1.275

Table 1 - Set point voltage vs. VID codes.

PIN DESCRIPTIONS

PIN#	PIN SYMBOL	PIN DESCRIPTION
1	Ct	This pin programs the oscillator frequency in the range of 50 KHz to 500KHz by means of an external capacitor connected from this pin to the ground.
2	Lin1	Controls the gate of an external MOSFET for the AGTL+ linear regulator or 1.8V supply.
3	V _{FB1}	This pin provides the feedback for the linear regulator that its output drive is Lin1 pin.
4	V _{FB2}	This pin provides the feedback for the linear regulator that its output drive is Lin2 pin.
5	V5	5V supply voltage.
6	OVP	This pin provides an over voltage flag when the feedback pin V _{FB3} voltage exceeds 17%(Typical) of the set point for the V _{core} output.
7	PGd	This pin is an open collector output that switches LO when the output of the converter is not within $\pm 10\%$ (typ) of the nominal output voltage. When PGd pin switches LO the output saturation voltage is less than 0.4V at 3mA.
8	CS-	This pin is connected to the Source of the power MOSFET for the Core supply and it is the negative input for the internal current sensing circuitry.
9	CS+	This pin is connected to the Drain of the power MOSFET of the Core supply. It provides the positive sensing input for the internal current sensing circuitry. An external resistor programs the CS threshold depending on the R _{DS} of the power MOSFET. An external capacitor is placed in parallel with the programming resistor to provide high frequency noise filtering.
10	HDrv	Output driver for the high side power MOSFET.
11	PGnd	This is the power ground pin and must be connected directly to the gnd plane close to the source of the synchronous MOSFET. A high frequency capacitor (typically 1 μ F) must be connected from V12 pin to this pin for noise free operation.
12	Gnd	This pin must be connected directly to the ground plane. A high frequency capacitor (0.1 to 1 μ F) must be connected from V5 and V12 pins to this pin for noise free operation.
13	LDrv	Output driver for the power MOSFET, which is used as a synchronous switched rectifier.
14	V12	This pin is connected to the 12V supply and serves as the power V _{cc} pin for the output drivers. A high frequency capacitor (0.1 to 1 μ F) must be connected directly from this pin to Gnd pin in order to supply large instantaneous current pulses to the power MOSFET during the transitions.
15	V _{FB4}	This pin provides the feedback for the linear regulator that its output drive is Lin4 pin.
16	Lin4	This pin controls the gate of an external MOSFET for either the AGP Bus linear regulator or can be used as Power good detector for 1.2V AGTL+ bus.
17	SS	This pin provides the soft-start for the switching regulator. An internal current source charges an external capacitor that is connected from this pin to the ground which ramps up the outputs of the switching regulator, preventing the outputs from overshooting as well as limiting the inrush current. The second function of the Soft-Start cap is to provide long off time (HICCUP) for the synchronous MOSFET during current limiting.
18	V _{FB3}	This pin is connected directly to the output of the Core supply to provide feedback to the Error comparator.
19	D25	This pin programs the output voltage in 25mV steps based on the VID table. 40K internal pull-up to V _{cc} .
20	D3	MSB input to the DAC that programs the output voltage. This pin can be pulled-up externally by a 10K resistor to either 3.3V or 5V supply. 40K internal pull-up to V _{cc} .
21	D2	Input to the DAC that programs the output voltage. This pin can be pulled-up externally by a 10K resistor to either 3.3V or 5V supply. 40K internal pull-up to V _{cc} .
22	D1	Input to the DAC that programs the output voltage. This pin can be pulled-up externally by a 10K Ω resistor to either 3.3V or 5V supply. 40K internal pull-up to V _{cc} .
23	D0	LSB input to the DAC that programs the output voltage. This pin can be pulled-up externally by a 10K resistor to either 3.3V or 5V supply. 40K internal pull-up to V _{cc} .
24	Lin2	Controls the gate of an external MOSFET for the AGTL+ linear regulator or 1.8V supply.

BLOCK DIAGRAM

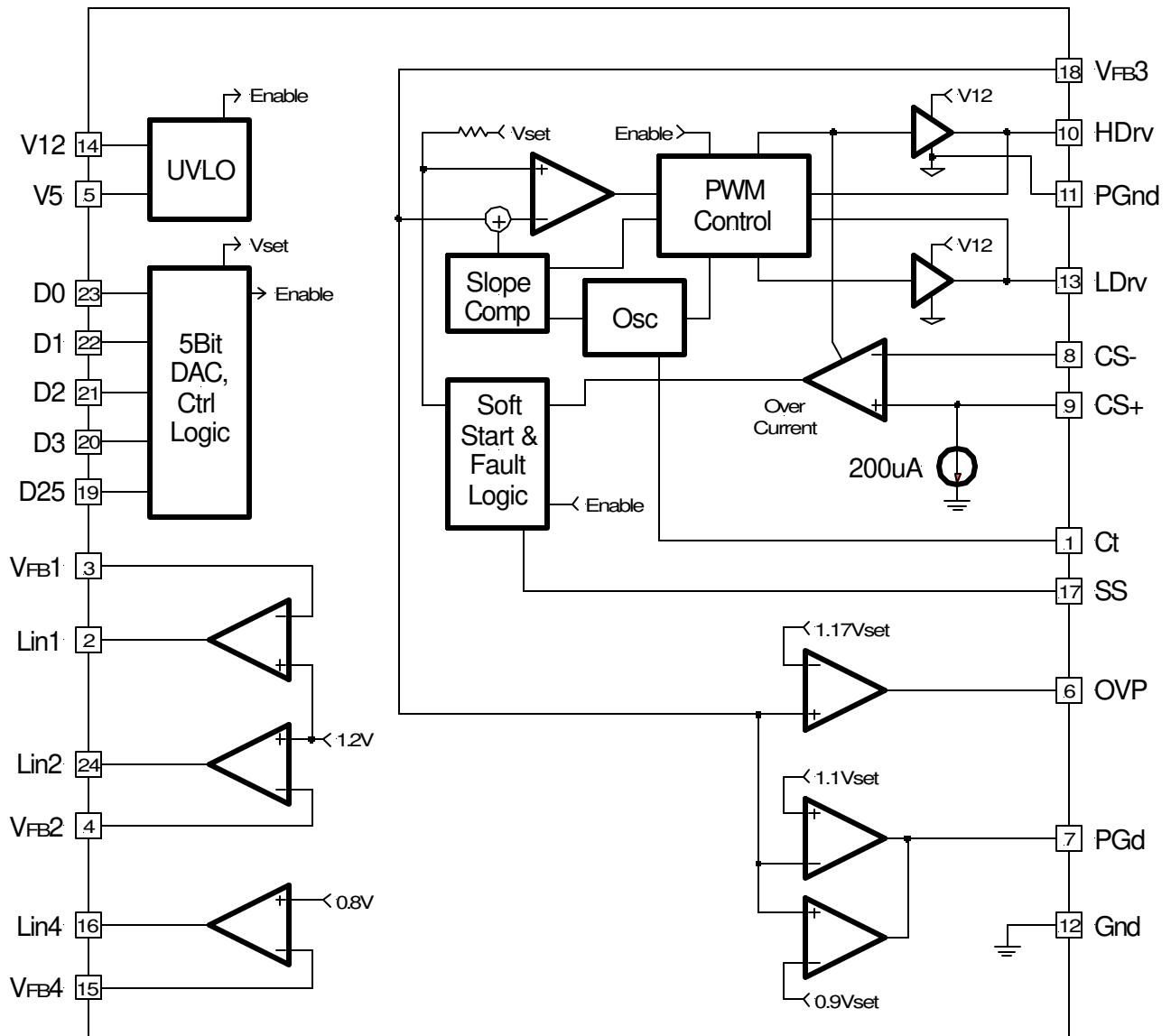

Figure 2 - Simplified block diagram of the IRU3013.

TYPICAL APPLICATION

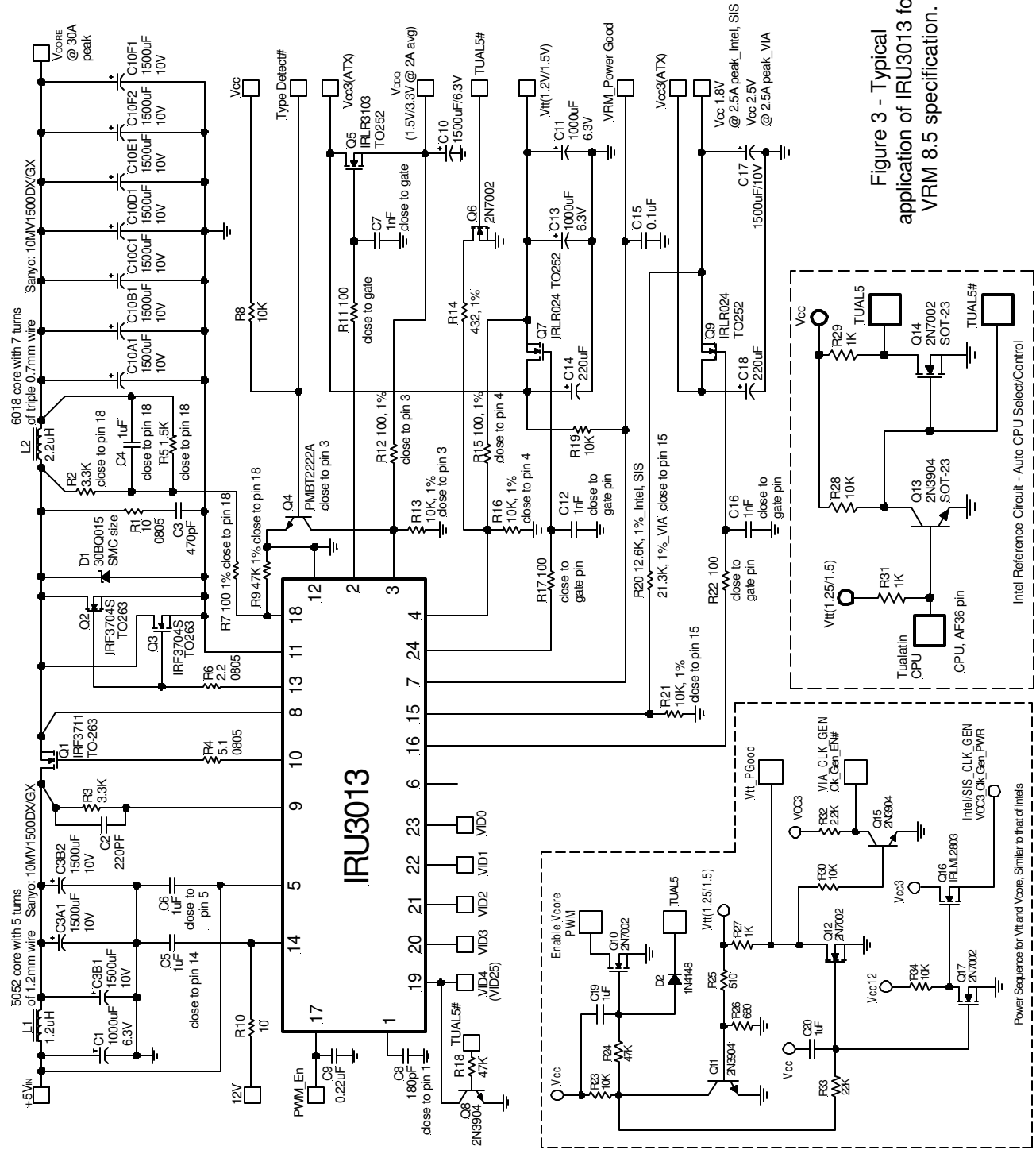
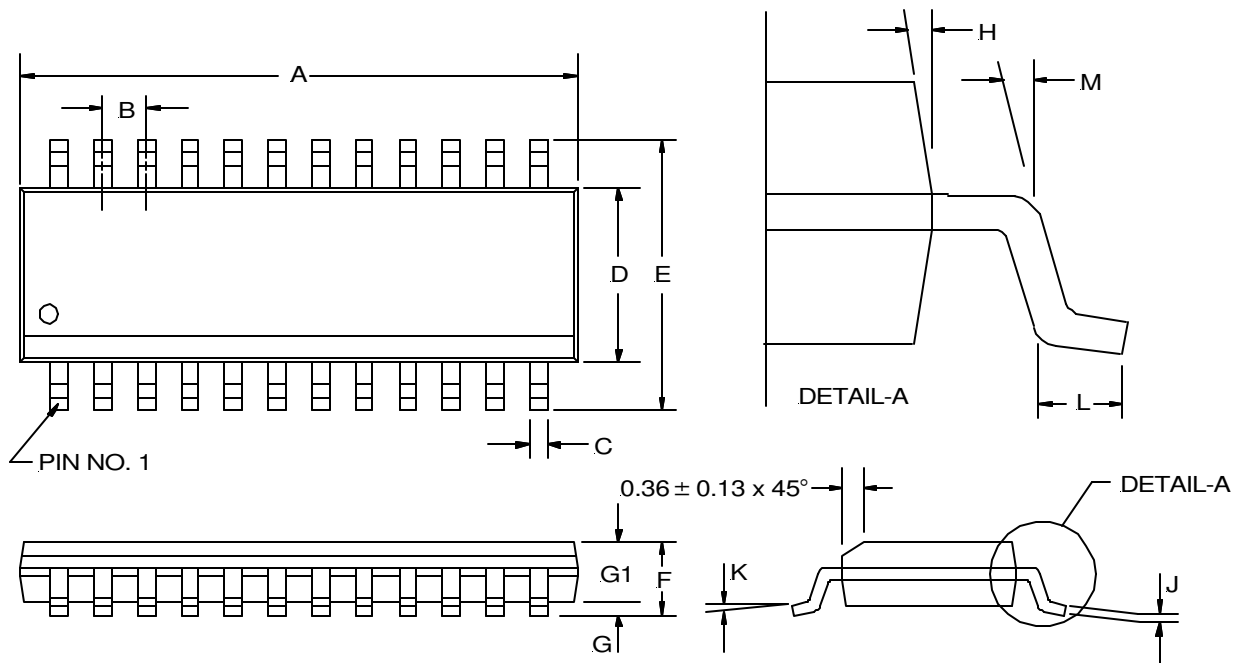

Figure 3 - Typical application of IRU3013 for VRM 8.5 specification.

IR WORLD HEADQUARTERS: 233 Kansas St., El Segundo, California 90245, USA Tel: (310) 252-7105
TAC Fax: (310) 252-7903
Visit us at www.irf.com for sales contact information
Data and specifications subject to change without notice. 02/01

**(Q) QSOP Package, Narrow Body
 24-Pin**



24-PIN		
SYMBOL	MIN	MAX
A	8.55	8.74
B	0.635 BSC	
C	0.20	0.30
D	3.81	3.99
E	5.79	6.20
F	1.35	1.75
G	0.10	0.25
G1	1.37	1.57
H	9° BSC	
J	0.19	0.25
K	0°	8°
L	0.40	1.27
M	7° ± 3°	

NOTE: ALL MEASUREMENTS ARE IN MILLIMETERS.

(W) SOIC Package
24-Pin Surface Mount, Wide Body

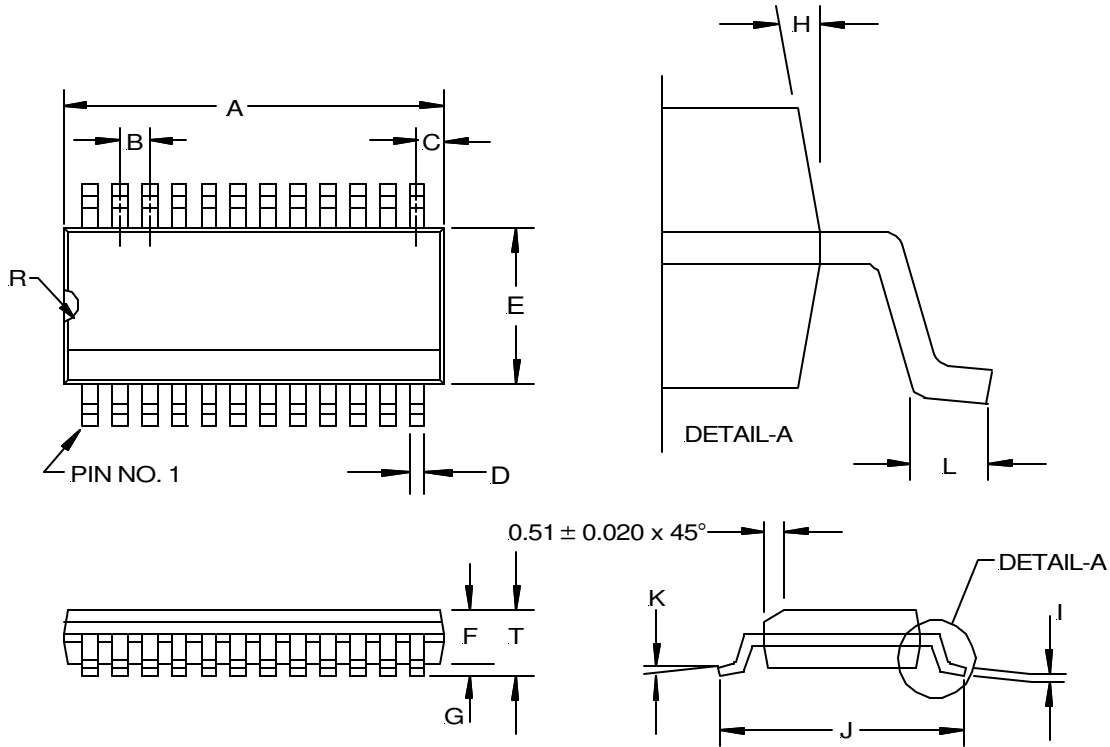

SYMBOL	24-PIN	
	MIN	MAX
A	15.20	15.40
B	1.27 BSC	
C	0.66 REF	
D	0.36	0.46
E	7.40	7.60
F	2.44	2.64
G	0.10	0.30
I	0.23	0.32
J	10.11	10.51
K	0°	8°
L	0.51	1.01
R	0.63	0.89
T	2.44	2.64

NOTE: ALL MEASUREMENTS ARE IN MILLIMETERS.

PACKAGE SHIPMENT METHOD

PKG DESIG	PACKAGE DESCRIPTION	PIN COUNT	PARTS PER TUBE	PARTS PER REEL	T & R Orientation
Q	QSOP Plastic, Narrow Body	24	---	1500	Fig A
W	SOIC, Wide Body	24	31	1000	Fig B

