

MTD. | Latch clamps

Steel



- 1
- 2
- 3
- 4
- 5
- 6
- 7
- 8
- 9
- 10
- 11
- 12
- 13
- 14
- 15
- 16
- 17
- 18

MATERIAL

C10 zinc-plated steel.

RIVETS

Zinc-plated steel.

PULLING HOOK

Perpendicular to clamping arm, zinc-plated steel.

OSCILLATING PIN AND NUTS

Zinc-plated steel.

HANDLE

Polyurethane, red colour.

FEATURES AND APPLICATIONS

All articulated joints are lubricated with special grease.

MTD. clamps ensure tight closing of any cover.

The position of the pulling hook can be adjusted in length according to the specific applications.

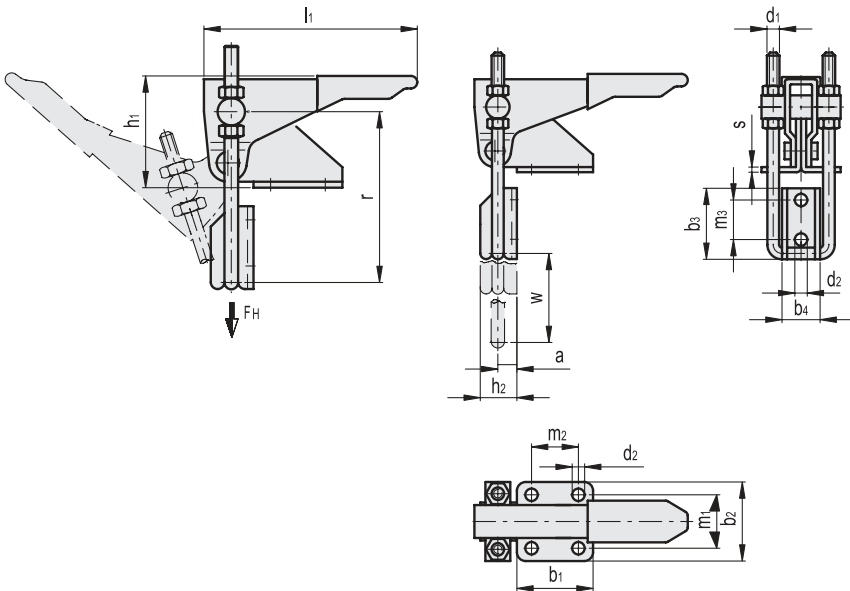
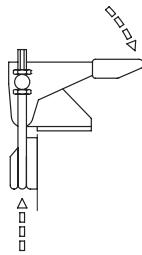

METRIC

Code	Description	a	b1	b2	b3	b4	d1	d2	h1	h2	l1	m1	m2	m3	r	s	Stroke w	FH [N]*	Δ
GG.AL530	MTD.160-T3	5	26	35	25.5	14	M4	4.3	36	10	68	22	13	14.3	48+58	2	34.5	1600	100
GG.AL535	MTD.320-T3	8	36	44	37	22	M6	6.5	52.5	15	106	25.5	19	20.5	75+95	3	53	3200	320
GG.AL540	MTD.700-T3	13	52	54	48.5	26	M8	8.5	66	23	147	36.5	32	27	98+122	3.5	64	7500	680

* Holding force.

Toggle clamps

1634



Models all rights reserved in accordance with the law. Always mention the source when reproducing our drawings and photos.

