

used for: D-SUB

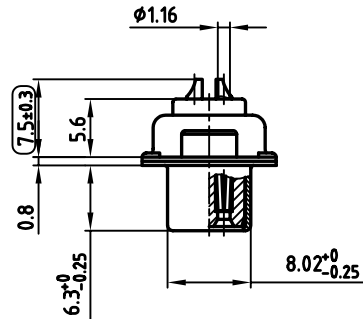
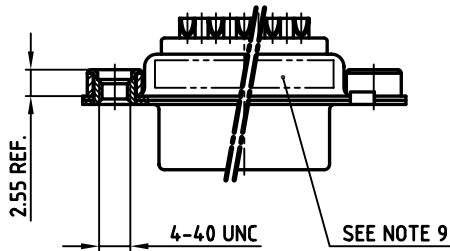
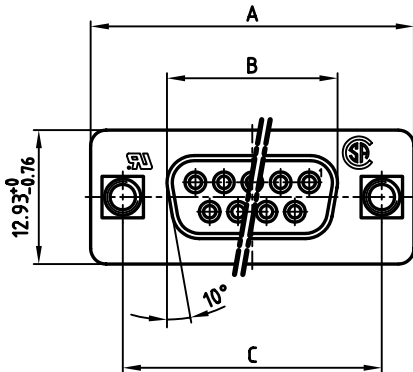

NOTES:

1. METALSHELLS: STEEL; min. 320µ" TIN
2. INSULATORS: PBT GF UL 94 V-0, BLACK
3. CONTACTS: COPPER ALLOY
4. PLATING: min. 8µ" HARD GOLD OVER min. 50µ" NICKEL
5. THREADED INSERT: COPPER ALLOY; min. 200µ" TIN over 80µ" NICKEL
6. COLLAR INSERT: COPPER ALLOY; min. 200µ" TIN over 80µ" NICKEL
7. MAXIMUM TORQUE VALUE FOR THREAD: 6" LBS
8. SOLDER CUP ACCEPTS CABLE AWG 20
9. CONNECTOR IS PART MARKED: PART-NO. CONEC ABC
10. = CHECK DIMENSION

POS.	A -0.76	B -0.25	C	Part No:
9	31.19	16.46	25.00 ± 0.12 ± 0.13	164A10219X
15	39.52	24.79	33.30 ± 0.15 ± 0.17	164A10229X
25	53.42	38.50	47.04 ± 0.13	164A10239X
37	69.70	54.96	63.50 ± 0.13	164A10249X

Directive 2002/95/EC
"RoHS"
Compliant

APPROVAL * FREIGABE * DEBLOCAGE * AUTORIZACION * APPROVAL	
CUSTOMER APPROVAL DATE:	
NAME:	TITLE:
COMPANY NAME:	
APPROVAL * FREIGABE * DEBLOCAGE * AUTORIZACION * APPROVAL	

THIS DRAWING MAY NOT BE COPIED OR REPRODUCED IN ANY WAY, AND MAY NOT BE PASSED ON TO A THIRD PARTY, WITHOUT WRITTEN PERMISSION. OWNERSHIP AND COPYRIGHT OF CONEC GmbH DO NOT ALTER CAD DRAWING BY HAND

rev.	description	date	name

tolerance		dim. in mm
2004	date	
drawn	04.11.	name
appd.	04.11.	Mickenbecker
norm	DIN 41652	
d-old		
CONEC ®		

scale:	2:1	
material:	SEE NOTES	
title:	D-SUB FEMALE Solder cup accepts cable AWG 20 with threaded insert, 9 - 37 pos.	
dwg no:	AutoCAD 2004	DIN-A
	16K1A1264	3
		sh: 1/1
part no:	SEE TABLE	